

MOUNTAINSIDE PHASE 1

A PLANNED RESIDENTIAL UNIT DEVELOPMENT LOCATED IN THE NORTHWEST QUARTER OF SECTION 22, AND THE SOUTHWEST QUARTER OF SECTION 15, TOWNSHIP 7 NORTH, RANGE 1 EAST, SALT LAKE BASE AND MERIDIAN, WEBER COUNTY, UTAH JUNE 2016

BOUNDARY DESCRIPTION

A PART OF THE SOUTHWEST QUARTER OF SECTION 15, TOWNSHIP 7 NORTH, RANGE 1 EAST OF THE SALT LAKE BASE AND MERIDIAN, MORE PARTICULARLY DESCRIBED AS FOLLOWS: BEGINNING AT A POINT BEING LOCATED NORTH 0°20'34" EAST 665.38 FEET ALONG THE WEST LINE OF SAID SOUTHWEST QUARTER AND NORTH 0°00'00" EAST 707.44 FEET FROM THE SOUTHWEST CORNER OF SAID SECTION; RUNNING THENCE NORTH 41°11'02" WEST 188.12 FEET; THENCE NORTH 18°32'40" WEST 105.78 FEET; THENCE NORTH 12°29'05" WEST 124.25 FEET; THENCE NORTH 10°14'13" WEST 171.74 FEET; THENCE NORTH 23°17'32" WEST 86.03 FEET; THENCE NORTH 40°27'51" WEST 87.66 FEET; THENCE NORTH 41°56'03" WEST 90.00 FEET; THENCE NORTH 29°27'11" WEST 133.15 FEET; THENCE NORTH 43°14'46" WEST 320.18 FEET; THENCE NORTH 20°27'46" WEST 145.52 FEET; THENCE NORTH 65°27'31" EAST 145.81 FEET; THENCE NORTH 74°48'21" EAST 60.81 FEET; THENCE NORTH 65°27'31" EAST 150.00 FEET; THENCE SOUTH 24°32'29" EAST 100.00 FEET; THENCE SOUTH 41°29'36" EAST 192.31 FEET; THENCE SOUTH 49°43'28" EAST 265.29 FEET; THENCE SOUTH 41°54'47" EAST 95.87 FEET; THENCE SOUTH 21°36'21" EAST 122.13 FEET; THENCE SOUTH 8°16'31" EAST 353.98 FEET; THENCE SOUTH 81°43'29" WEST 25.56 FEET; THENCE SOUTH 16°45'43" EAST 190.57 FEET; THENCE NORTH 73°14'17" EAST 26.00 FEET; THENCE SOUTH 16°45'43" EAST 120.00 FEET; THENCE SOUTH 73°14'17" WEST 70.00 FEET TO A COMMON POINT WITH PARKSIDE PRUD PHASE 1; THENCE ALONG THE BOUNDARY OF SAID PRUD SOUTH 39°18'16" WEST 60.84 FEET; THENCE CONTINUING ALONG SAID BOUNDARY SOUTH 48°48'58" WEST 67.96 FEET; THENCE SOUTH 76°19'34" WEST 92.50 FEET TO THE POINT OF BEGINNING. CONTAINING 517,646 SQ.FT. OR 11.884 ACRES, MORE OR LESS.

OWNER'S DEDICATION

I THE UNDERSIGNED OWNER OF THE HEREON DESCRIBED TRACT OF LAND, HEREBY SET APART AND SUBDIVIDE THE SAME INTO LOTS, PARCELS AND STREETS AS SHOWN ON THIS PLAT AND NAME SAID TRACT:

MOUNTAINSIDE PHASE 1

AND HEREBY DEDICATE, GRANT AND CONVEY TO WEBER COUNTY, UTAH ALL THOSE PARTS OR PORTIONS OF SAID TRACT OF LAND DESIGNATED AS STREETS, THE SAME TO BE USED AS PUBLIC THOROUGHFARES FOREVER, AND ALSO GRANT AND DEDICATE A PERPETUAL EASEMENT OVER, UPON AND UNDER THE LANDS DESIGNATED ON THE PLAT AS PUBLIC UTILITY, THE SAME TO BE USED FOR THE INSTALLATION, MAINTENANCE AND OPERATION OF PUBLIC UTILITY SERVICE LINES, STORM DRAINAGE FACILITIES OR FOR THE PERPETUAL PRESERVATION OF WATER DRAINAGE CHANNELS IN THEIR NATURAL STATE WHICHEVER IS APPLICABLE AS MAY BE AUTHORIZED BY PLAIN CITY, UTAH, WITH NO BUILDINGS OR STRUCTURES BEING ERRECTED WITHIN SUCH EASEMENTS, AND ALSO DEDICATE, GRANT AND CONVEY TO WEBER COUNTY A TEMPORARY TURN AROUND EASEMENT AS SHOWN HEREON TO BE USED BY THE PUBLIC UNTIL SUCH TIME THAT THE ROAD IS EXTENDED. THE TEMPORARY TURN AROUND EASEMENT SHALL BE REVOKED AND NULLIFIED AT THE EVENT OF THE EXTENSION OF THE ROAD WITHOUT FURTHER WRITTEN DOCUMENT AND THE ENCUMBERED LAND WITHIN THE AFFECTED PROPERTY SHALL BE RELEASED FOR THE FULL AND EXCLUSIVE USE AND BENEFIT OF THE PROPERTY OWNERS.

SIGNED THIS ___ DAY OF ___, 2016.

BY: _____

SURVEYOR'S CERTIFICATE

I, KLINT H. WHITNEY, DO HEREBY CERTIFY THAT I AM A LICENSED PROFESSIONAL LAND SURVEYOR IN THE STATE OF UTAH AND THAT I HOLD CERTIFICATE NO. 8227228 IN ACCORDANCE WITH TITLE 58, CHAPTER 22, OF THE PROFESSIONAL ENGINEERS AND LAND SURVEYORS ACT. I FURTHER CERTIFY THAT BY AUTHORITY OF THE OWNERS I HAVE COMPLETED A SURVEY OF THE PROPERTY AS SHOWN AND DESCRIBED ON THIS PLAT, AND HAVE SUBDIVIDED SAID PROPERTY INTO LOTS AND STREETS, TOGETHER WITH EASEMENTS, HEREAFTER TO BE KNOWN AS MOUNTAINSIDE PHASE 1 IN ACCORDANCE WITH SECTION 17-23-20 AND HAVE VERIFIED ALL MEASUREMENTS; THAT THE REFERENCE MONUMENTS SHOWN HEREON ARE LOCATED AS INDICATED AND ARE SUFFICIENT TO RETRACE OR REESTABLISH THIS SURVEY; AND THAT THE INFORMATION SHOWN HEREIN IS SUFFICIENT TO ACCURATELY ESTABLISH THE LATERAL BOUNDARIES OF THE HEREIN DESCRIBED TRACT OF REAL PROPERTY.

SIGNED THIS ___ DAY OF ___, 2016.

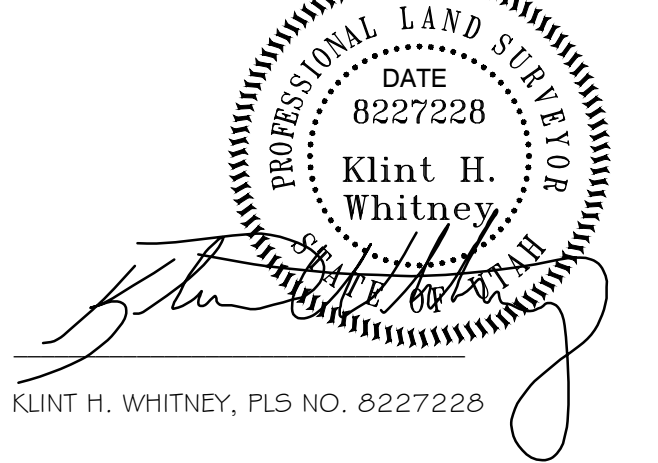

WEBER COUNTY ENGINEER

I HEREBY CERTIFY THAT THE REQUIRED PUBLIC IMPROVEMENT STANDARDS AND DRAWINGS FOR THIS SUBDIVISION CONFORM WITH COUNTY STANDARDS AND THE AMOUNT OF THE FINANCIAL GUARANTEE IS SUFFICIENT FOR THE INSTALLATION OF THESE IMPROVEMENTS.

SIGNED THIS ___ DAY OF ___, 2016.

COUNTY ENGINEER

NOTES

- 1. ZONE (XXX) CURRENT YARD SETBACKS:
2. SUBJECT PROPERTY FALLS WITHIN FEMA FLOOD ZONE "X" - AREAS DETERMINED TO BE OUTSIDE THE 0.2% ANNUAL CHANCE FLOODPLAIN. PER FEMA MAP NO. 49057C0431E WITH AN EFFECTIVE DATE OF DECEMBER 16, 2005.
3.

AGRICULTURAL NOTE: AGRICULTURE IS THE PREFERRED USE IN THE AGRICULTURE ZONES. AGRICULTURE OPERATIONS AS SPECIFIED IN THE ZONING ORDINANCE FOR A PARTICULAR ZONE ARE PERMITTED AT ANY TIME INCLUDING THE OPERATION OF FARM MACHINERY AND NO ALLOWED AGRICULTURE USE SHALL BE SUBJECT TO RESTRICTION ON THAT IT INTERFERES WITH ACTIVITIES OF FUTURE RESIDENTS OF THIS SUBDIVISION.

NARRATIVE

THE PURPOSE OF THIS SURVEY WAS TO CREATE A TWO LOT SUBDIVISION ON THE PROPERTY AS SHOWN AND DESCRIBED HEREON. THE SURVEY WAS ORDERED BY XXXXX. THE BASIS OF BEARING IS THE NORTH LINE OF THE NORTHEAST QUARTER OF SECTION 16, TOWNSHIP 6 NORTH, RANGE 2 WEST, OF THE SALT LAKE BASE AND MERIDIAN WHICH BEARS NORTH 89°26'19" WEST WEBER COUNTY, UTAH NORTH, NAD 83 STATE PLANE GRID BEARING. THE RIGHT-OF-WAY OF XXXXX STREET WAS ESTABLISHED BY HONORING THE PROJECTED RIGHT-OF-WAY DEDICATION OF THE XXXXX SUBDIVISION.

WEBER COUNTY COMMISSION ACCEPTANCE

THIS IS TO CERTIFY THAT THIS SUBDIVISION PLAT, THE DEDICATION OF STREETS AND OTHER PUBLIC WAYS AND FINANCIAL GUARANTEE OF PUBLIC IMPROVEMENTS ASSOCIATED WITH THIS SUBDIVISION THEREON ARE HEREBY APPROVED AND ACCEPTED BY THE COMMISSIONERS OF WEBER COUNTY, UTAH.

SIGNED THIS ___ DAY OF ___, 2016.

CHAIRMAN, WEBER COUNTY COMMISSION NAME/TITLE

ACKNOWLEDGEMENT

STATE OF UTAH
COUNTY OF WEBER

On this ___ day of ___, 2016, personally appeared before me (NAME OF DOCUMENT SIGNER), whose identity is personally known to me (or proven on the basis of satisfactory evidence) and who by me duly sworn/affirmed, did say that he/she is the (TITLE OR OFFICE) of (NAME OF CORPORATION), and that said document was signed by him/her in behalf of said Corporation by Authority of its Bylaws, or (Resolution of its Board of Directors), and said (NAME OF DOCUMENT SIGNER) acknowledged to me that said Corporation executed the same.

STAMP NOTARY PUBLIC

WEBER COUNTY PLANNING COMMISSION APPROVAL

THIS IS TO CERTIFY THAT THIS SUBDIVISION WAS DULY APPROVED BY THE WEBER COUNTY PLANNING COMMISSION.

SIGNED THIS ___ DAY OF ___, 2016.

CHAIRMAN, WEBER COUNTY PLANNING COMMISSION

WEBER - MORGAN HEALTH DEPARTMENT

I do hereby certify that the soils, percolation rates, and site condition for this subdivision have been investigated by this office and are approved for on-site wastewater disposal systems.

This ___ day of ___, 2016

Director Weber-Morgan Health Department

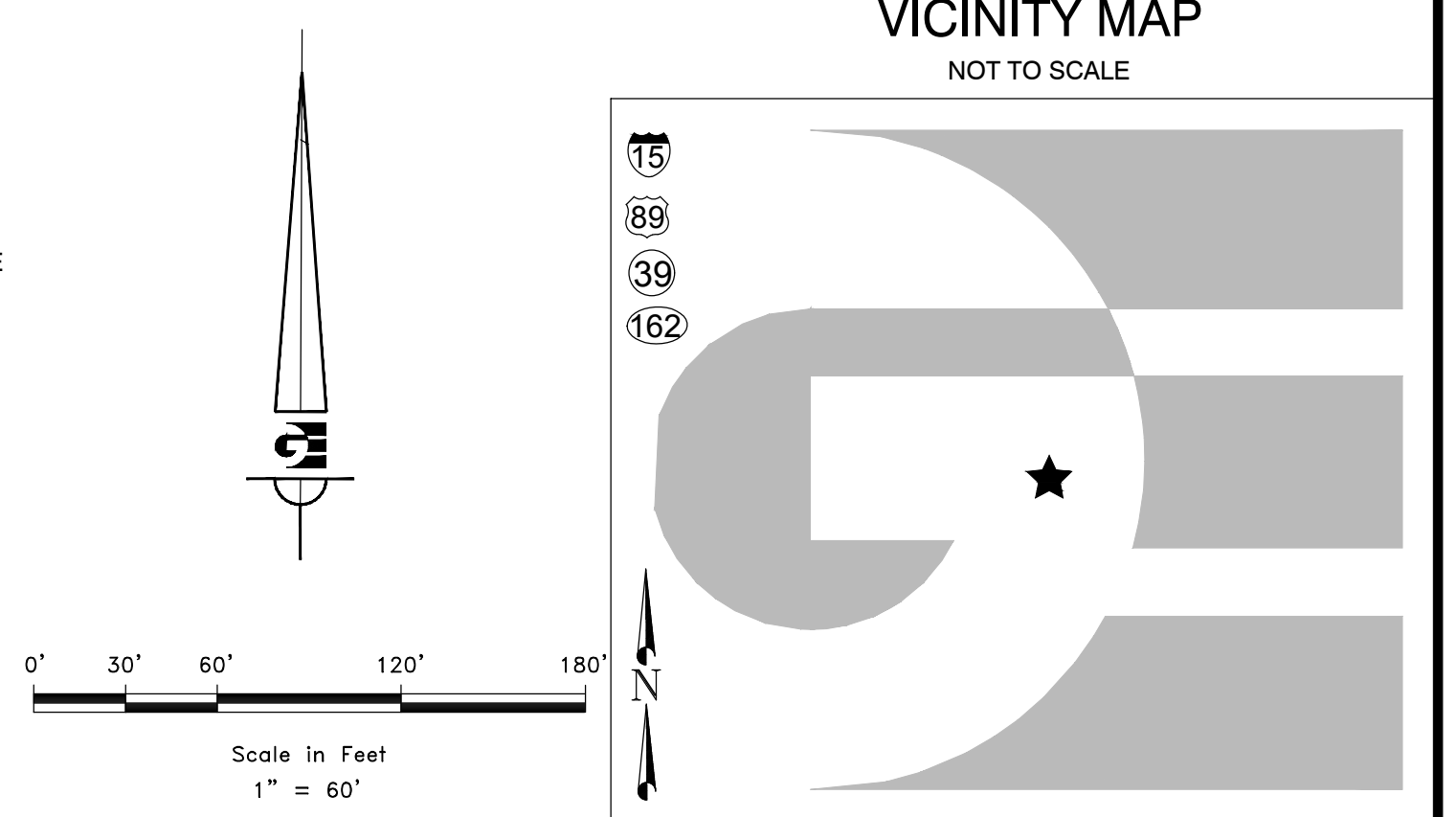

County Recorder section with fields for Name, Address, Fee Paid, and Records. Includes Gardner Engineering logo and contact information: 5150 SOUTH 375 EAST OGDEN, UT OFFICE: 801.476.0202 FAX: 801.476.0066

R:\1201 - LEWIS HOMES\THE BRIDGES\SURVEY\DWG\MOUNTAINSIDE PHASE 1.DWG

MOUNTAINSIDE PHASE 1
 A PLANNED RESIDENTIAL UNIT DEVELOPMENT
 LOCATED IN THE NORTHWEST QUARTER OF SECTION 22,
 AND THE SOUTHWEST QUARTER OF SECTION 15,
 TOWNSHIP 7 NORTH, RANGE 1 EAST, SALT LAKE BASE AND MERIDIAN,
 WEBER COUNTY, UTAH
 JUNE 2016

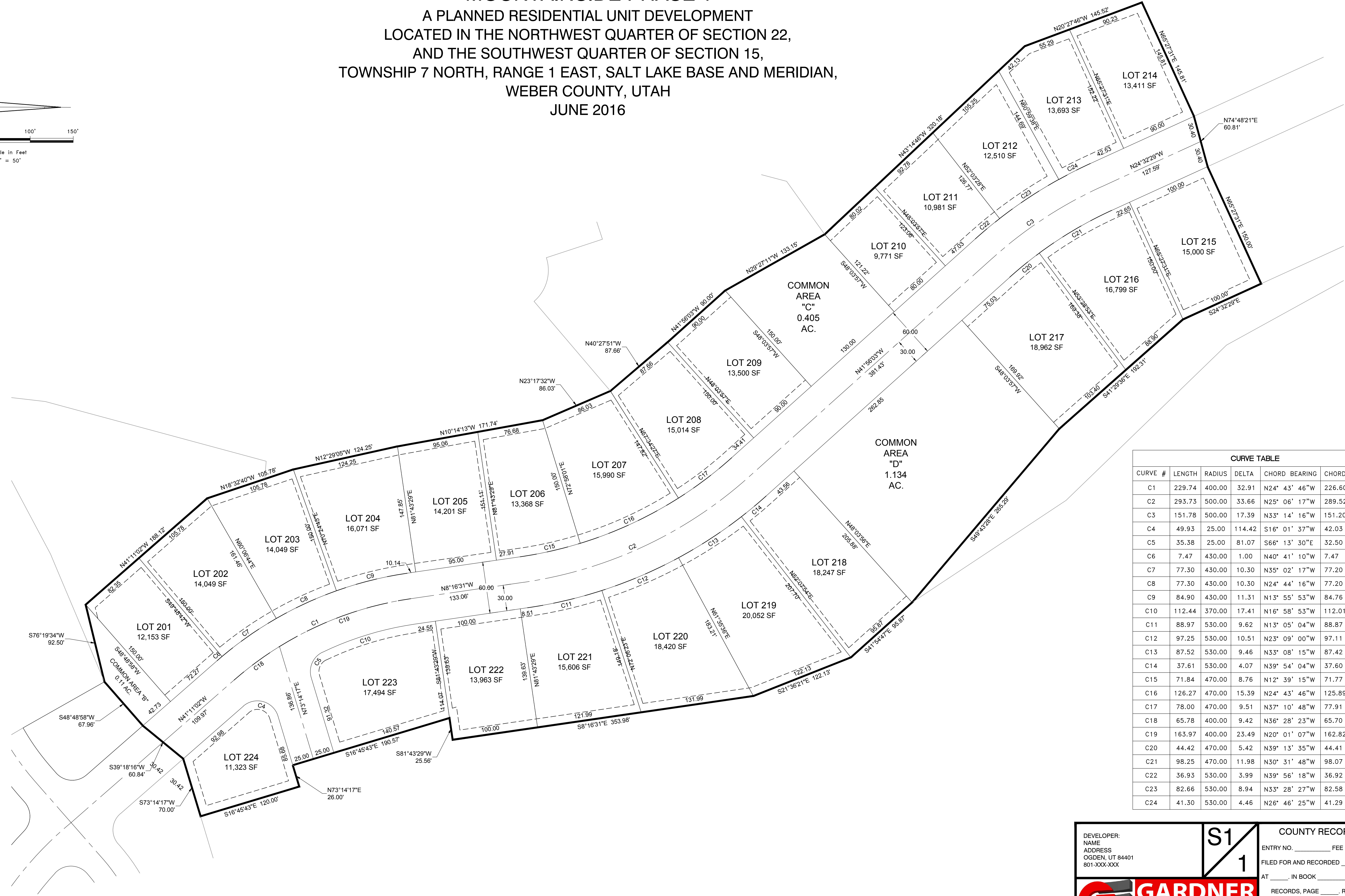
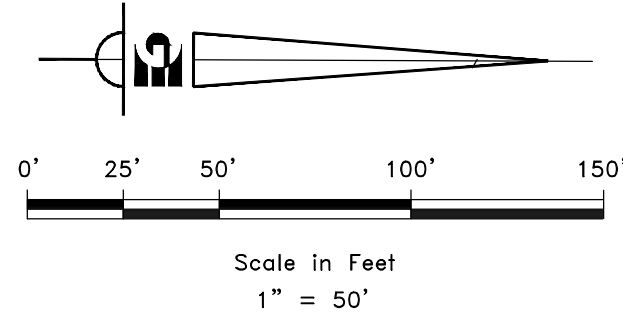

CURVE TABLE					
CURVE #	LENGTH	RADIUS	DELTA	CHORD BEARING	CHORD LENGTH
C1	229.74	400.00	32.91	N24° 43' 46"W	226.60
C2	293.73	500.00	33.66	N25° 06' 17"W	289.52
C3	151.78	500.00	17.39	N33° 14' 16"W	151.20
C4	49.93	25.00	114.42	S16° 01' 37"W	42.03
C5	35.38	25.00	81.07	S66° 13' 30"E	32.50
C6	7.47	430.00	1.00	N40° 41' 10"W	7.47
C7	77.30	430.00	10.30	N35° 02' 17"W	77.20
C8	77.30	430.00	10.30	N24° 44' 16"W	77.20
C9	84.90	430.00	11.31	N13° 55' 53"W	84.76
C10	112.44	370.00	17.41	N16° 58' 53"W	112.01
C11	88.97	530.00	9.62	N13° 05' 04"W	88.87
C12	97.25	530.00	10.51	N23° 09' 00"W	97.11
C13	87.52	530.00	9.46	N33° 08' 15"W	87.42
C14	37.61	530.00	4.07	N39° 54' 04"W	37.60
C15	71.84	470.00	8.76	N12° 39' 15"W	71.77
C16	126.27	470.00	15.39	N24° 43' 46"W	125.89
C17	78.00	470.00	9.51	N37° 10' 48"W	77.91
C18	65.78	400.00	9.42	N36° 28' 23"W	65.70
C19	163.97	400.00	23.49	N20° 01' 07"W	162.82
C20	44.42	470.00	5.42	N39° 13' 35"W	44.41
C21	98.25	470.00	11.98	N30° 31' 48"W	98.07
C22	36.93	530.00	3.99	N39° 56' 18"W	36.92
C23	82.66	530.00	8.94	N33° 28' 27"W	82.58
C24	41.30	530.00	4.46	N26° 46' 25"W	41.29

R:\1201 - LEWIS HOMES\THE BRIDGES\SURVEY\DWG\MOUNTAINSIDE PHASE 1.DWG

DEVELOPER: NAME ADDRESS OGDEN, UT 84401 801-XXX-XXX	S1	COUNTY RECORDER ENTRY NO. _____ FEE PAID _____ FILED FOR AND RECORDED _____ AT _____ IN BOOK _____ OF OFFICIAL RECORDS, PAGE _____, RECORDED FOR _____ COUNTY RECORDER BY: _____
	1	
CIVIL - LAND PLANNING MUNICIPAL - LAND SURVEYING 5150 SOUTH 375 EAST OGDEN, UT OFFICE: 801.476.0202 FAX: 801.476.0066		