

PARKSIDE P.R.U.D. PHASE 1

A PLANNED RESIDENTIAL UNIT DEVELOPMENT LOCATED IN THE NORTHWEST QUARTER OF SECTION 22, AND THE SOUTHWEST QUARTER OF SECTION 15, TOWNSHIP 7 NORTH, RANGE 1 EAST, SALT LAKE BASE AND MERIDIAN, WEBER COUNTY, UTAH JUNE 2016

VICINITY MAP
NOT TO SCALE

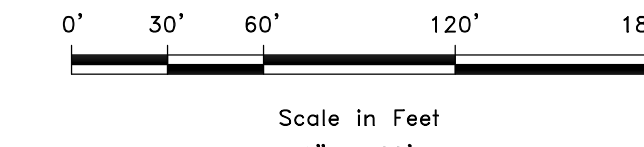
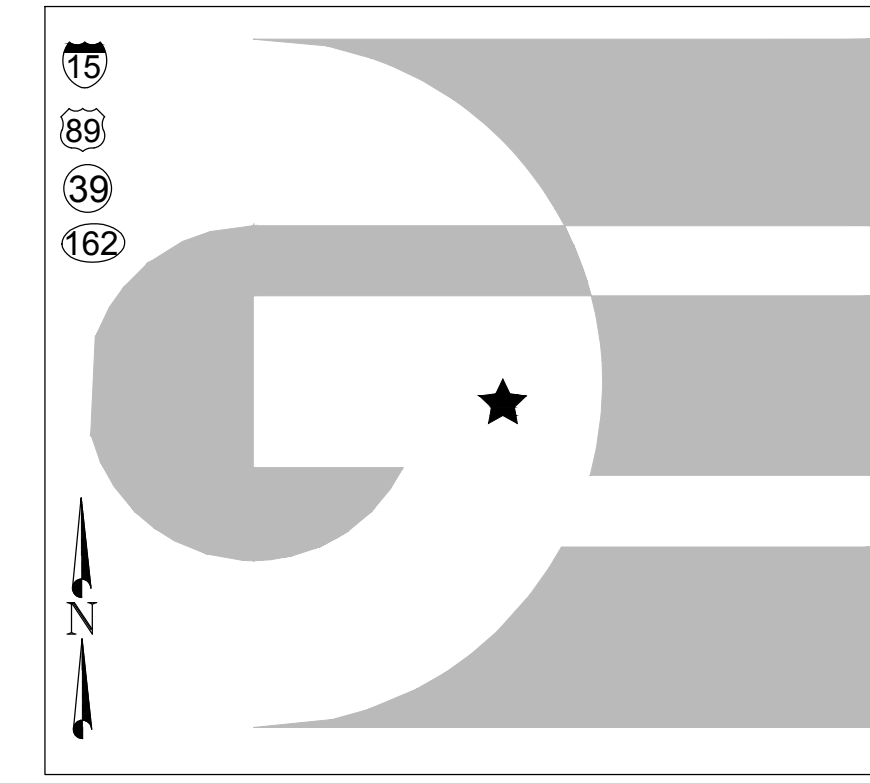

LEGEND

- WEBER COUNTY MONUMENT AS NOTED
- SET 24" REBAR AND CAP MARKED GARDNER ENGINEERING
- SUBDIVISION BOUNDARY
- LOT LINE
- ADJACENT PARCEL
- SECTION LINE
- EXISTING FENCE
- PUBLIC UTILITY EASEMENT

A PART OF THE SOUTHWEST QUARTER OF SECTION 15, AND THE NORTHWEST QUARTER OF SECTION 22, TOWNSHIP 7 NORTH, RANGE 1 EAST OF THE SALT LAKE BASE AND MERIDIAN, MORE PARTICULARLY DESCRIBED AS FOLLOWS: BEGINNING AT A POINT ON THE SOUTH LINE OF SAID SECTION 15, BEING LOCATED SOUTH 89°12'43" EAST 148.21 FEET ALONG SAID LINE FROM THE SOUTHEAST CORNER OF SAID SECTION, SAID POINT ALSO BEING THE SOUTHWEST CORNER OF THE SNOWFLAKE SUBDIVISION PHASE 3; RUNNING THENCE ALONG SAID SECTION LINE AND THE SOUTHERLY BOUNDARY OF SAID SUBDIVISION SOUTH 89°12'43" EAST 289.74 FEET TO THE NORTHERLY RIGHT-OF-WAY LINE OF FAIRWAYS DRIVE; THENCE ALONG SAID RIGHT-OF-WAY LINE ALONG THE ARC OF A CURVE TO THE LEFT 221.36 FEET, HAVING A RADIUS OF 390.00 FEET, A CENTRAL ANGLE OF 32°31'14", AND WHICH CHORD BEARS SOUTH 74°31'40" WEST 218.40 FEET; THENCE CONTINUING ALONG SAID RIGHT-OF-WAY LINE SOUTH 58°16'03" WEST 279.23 FEET; THENCE NORTH 31°43'43" WEST 84.67 FEET; THENCE ALONG THE ARC OF A CURVE TO THE RIGHT 102.00 FEET, HAVING A RADIUS OF 280.00 FEET, A CENTRAL ANGLE OF 20°52'19", AND WHICH CHORD BEARS NORTH 21°17'34" WEST 101.44 FEET; THENCE ALONG THE ARC OF A CURVE TO THE LEFT 35.15 FEET, HAVING A RADIUS OF 25.00 FEET, A CENTRAL ANGLE OF 80°33'53", AND WHICH CHORD BEARS NORTH 51°08'21" WEST 32.33 FEET; THENCE NORTH 88°34'43" EAST 33.67 FEET; THENCE SOUTH 1°25'17" EAST 114.83 FEET; THENCE SOUTH 88°34'43" WEST 133.38 FEET; THENCE SOUTH 29°26'32" WEST 43.31 FEET; THENCE NORTH 80°33'28" WEST 162.14 FEET; THENCE NORTH 29°26'32" EAST 143.70 FEET; THENCE SOUTH 73°20'57" EAST 30.75 FEET; THENCE ALONG THE ARC OF A CURVE TO THE RIGHT 111.55 FEET, HAVING A RADIUS OF 47.50 FEET, A CENTRAL ANGLE OF 134°33'00", AND WHICH CHORD BEARS NORTH 81°12'42" EAST 87.63 FEET; THENCE ALONG THE ARC OF A CURVE TO THE LEFT 29.54 FEET, HAVING A RADIUS OF 25.00 FEET, A CENTRAL ANGLE OF 67°42'33", AND WHICH CHORD BEARS SOUTH 65°22'05" EAST 27.85 FEET; THENCE NORTH 80°46'39" EAST 8.53 FEET; THENCE ALONG THE ARC OF A CURVE TO THE RIGHT 71.48 FEET, HAVING A RADIUS OF 525.00 FEET, A CENTRAL ANGLE OF 7°48'04", AND WHICH CHORD BEARS NORTH 84°40'41" EAST 71.43 FEET; THENCE NORTH 88°34'43" EAST 33.86 FEET; THENCE ALONG THE ARC OF A CURVE TO THE LEFT 35.15 FEET, HAVING A RADIUS OF 25.00 FEET, A CENTRAL ANGLE OF 80°33'53", AND WHICH CHORD BEARS NORTH 48°17'46" EAST 32.33 FEET; THENCE ALONG THE ARC OF A CURVE TO THE RIGHT 59.65 FEET, HAVING A RADIUS OF 280.00 FEET, A CENTRAL ANGLE OF 30°12'22", AND WHICH CHORD BEARS NORTH 14°07'02" EAST 59.54 FEET; THENCE NORTH 20°31'41" EAST 165.87 FEET; THENCE ALONG THE ARC OF A CURVE TO THE LEFT 105.53 FEET, HAVING A RADIUS OF 170.00 FEET, A CENTRAL ANGLE OF 35°34'05", AND WHICH CHORD BEARS NORTH 2°26'11" EAST 103.85 FEET; THENCE SOUTH 74°39'08" WEST 33.51 FEET; THENCE SOUTH 35°33'11" WEST 50.53 FEET; THENCE NORTH 50°07'17" WEST 160.00 FEET; THENCE ALONG THE ARC OF A CURVE TO THE LEFT 47.08 FEET, HAVING A RADIUS OF 175.00 FEET, A CENTRAL ANGLE OF 15°24'55", AND WHICH CHORD BEARS SOUTH 47°35'10" WEST 46.94 FEET; THENCE NORTH 34°42'22" WEST 49.57 FEET; THENCE NORTH 63°38'31" WEST 74.30 FEET; THENCE NORTH 72°56'39" WEST 68.45 FEET; THENCE NORTH 33°35'58" WEST 106.40 FEET; THENCE NORTH 30°10'47" WEST 50.00 FEET; THENCE NORTH 29°34'23" WEST 108.87 FEET; THENCE NORTH 48°48'58" EAST 67.96 FEET; THENCE NORTH 39°18'16" EAST 60.84 FEET; THENCE SOUTH 41°11'02" EAST 97.33 FEET; THENCE ALONG THE ARC OF A CURVE TO THE LEFT 39.27 FEET, HAVING A RADIUS OF 25.00 FEET, A CENTRAL ANGLE OF 90°00'00", AND WHICH CHORD BEARS SOUTH 86°11'02" EAST 35.36 FEET; THENCE NORTH 48°48'58" EAST 2.41 FEET; THENCE ALONG THE ARC OF A CURVE TO THE RIGHT 255.08 FEET, HAVING A RADIUS OF 255.00 FEET, A CENTRAL ANGLE OF 64°57'25", AND WHICH CHORD BEARS NORTH 81°17'40" EAST 241.64 FEET; THENCE SOUTH 64°41'06" EAST 227.30 FEET; THENCE ALONG THE ARC OF A CURVE TO THE LEFT 53.90 FEET, HAVING A RADIUS OF 175.00 FEET, A CENTRAL ANGLE OF 17°38'55", AND WHICH CHORD BEARS SOUTH 73°29'18" EAST 53.69 FEET TO A POINT ON THE BOUNDARY LINE OF SAID SNOWFLAKE SUBDIVISION PHASE 3; THENCE ALONG SAID LINE SOUTH 0°20'39" WEST 649.59 FEET TO THE POINT OF BEGINNING. CONTAINING 380.73 SQ. FT. OR 8.740 ACRES, MORE OR LESS.

OWNER'S DEDICATION

I THE UNDERSIGNED OWNER OF THE HEREON DESCRIBED TRACT OF LAND, HEREBY SET APART AND SUBDIVIDE THE SAME INTO LOTS, PARCELS AND STREETS AS SHOWN ON THIS PLAT AND NAME SAID TRACT:

PARKSIDE P.R.U.D. PHASE 1

AND HEREBY DEDICATE, GRANT AND CONVEY TO WEBER COUNTY, UTAH ALL THOSE PARTS OR PORTIONS OF SAID TRACT OF LAND DESIGNATED AS STREETS, THE SAME TO BE USED AS PUBLIC THOROUGHFARES FOREVER, AND ALSO GRANT AND DEDICATE A PERPETUAL EASEMENT OVER, UPON AND UNDER THE LANDS DESIGNATED ON THE PLAT AS PUBLIC UTILITY, THE SAME TO BE USED FOR THE INSTALLATION, MAINTENANCE AND OPERATION OF PUBLIC UTILITY SERVICE LINES, STORM DRAINAGE FACILITIES OR FOR THE PERPETUAL PRESERVATION OF WATER DRAINAGE CHANNELS IN THEIR NATURAL STATE WHICHEVER IS APPLICABLE AS MAY BE AUTHORIZED BY WEBER COUNTY UTAH, WITH NO BUILDINGS OR STRUCTURES BEING ERRECTED WITHIN SUCH EASEMENTS, AND FURTHER GRANT AND CONVEY TO THE SUBDIVISION LOT (UNIT) OWNERS ASSOCIATION, ALL THOSE PARTS OR PORTIONS OF SAID TRACT OF LAND DESIGNATED AS COMMON AREAS TO BE USED FOR RECREATIONAL AND OPEN SPACE PURPOSES FOR THE BENEFIT OF EACH LOT (UNIT) OWNERS ASSOCIATION MEMBER IN COMMON WITH ALL OTHERS IN THE SUBDIVISION AND SUBSEQUENT PHASES OF THE DEVELOPMENT AND DEDICATE TO WEBER COUNTY A PERPETUAL OPEN SPACE RIGHT AND EASEMENT ON AND OVER THE COMMON AREAS TO GUARANTEE TO WEBER COUNTY THAT THE COMMON AREAS REMAIN OPEN AND UNDEVELOPED EXCEPT FOR APPROVED RECREATIONAL, PARKING AND OPEN SPACE PURPOSES.

ACKNOWLEDGEMENT

STATE OF UTAH)
COUNTY OF WEBER)

On this _____ day of _____, 2016, personally appeared before me (NAME OF DOCUMENT SIGNER), whose identity is personally known to me (or proven on the basis of satisfactory evidence) and who by me duly sworn/affirmed, did say that he/she is the (TITLE OR OFFICE) of (NAME OF CORPORATION), and that said document was signed by him/her in behalf of said "Corporation by Authority of its Bylaws, or (Resolution of its Board of Directors), and said (NAME OF DOCUMENT SIGNER) acknowledged to me that said "Corporation executed the same.

SIGNED THIS _____ DAY OF _____, 2016.

BY: _____

SURVEYOR'S CERTIFICATE

I, KLINT H. WHITNEY, DO HEREBY CERTIFY THAT I AM A LICENSED PROFESSIONAL LAND SURVEYOR IN THE STATE OF UTAH AND THAT I HOLD CERTIFICATE NO. 8227228 IN ACCORDANCE WITH TITLE 58, CHAPTER 22, OF THE PROFESSIONAL ENGINEERS AND LAND SURVEYORS ACT; I FURTHER CERTIFY THAT BY AUTHORITY OF THE OWNERS I HAVE COMPLETED A SURVEY OF THE PROPERTY AS SHOWN AND DESCRIBED ON THIS PLAT, AND HAVE SUBDIVIDED SAID PROPERTY INTO LOTS AND STREETS, TOGETHER WITH EASEMENTS, HEREAFTER TO BE KNOWN AS PARKSIDE P.R.U.D. PHASE 1 IN ACCORDANCE WITH SECTION 17-23-20 AND HAVE VERIFIED ALL MEASUREMENTS; THAT THE REFERENCE MONUMENTS SHOWN HEREON ARE LOCATED AS INDICATED AND ARE SUFFICIENT TO RETRACE OR REESTABLISH THIS SURVEY; AND THAT THE INFORMATION SHOWN HEREIN IS SUFFICIENT TO ACCURATELY ESTABLISH THE LATERAL BOUNDARIES OF THE HEREIN DESCRIBED TRACT OF REAL PROPERTY.

SIGNED THIS _____ DAY OF _____, 2016.

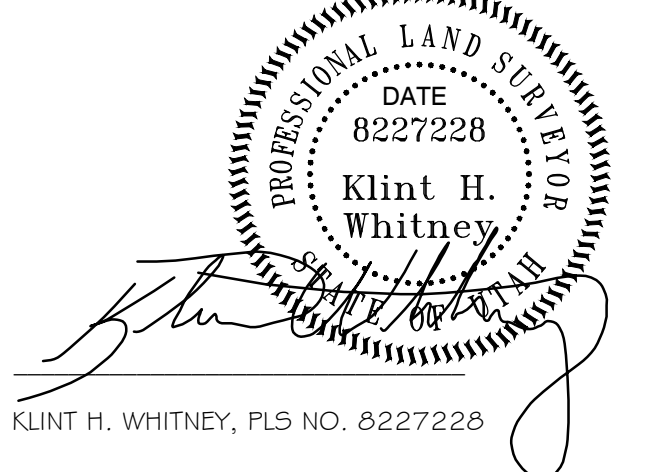

NOTES

- ZONE RE-15 CURRENT YARD SETBACKS.
- SUBJECT PROPERTY FALLS WITHIN FEMA FLOOD ZONE "X" - AREAS DETERMINED TO BE OUTSIDE THE 0.2% ANNUAL CHANCE FLOODPLAIN. PER FEMA MAP NO. 49057C0229F WITH AN EFFECTIVE DATE OF DECEMBER 16, 2005.
-

AGRICULTURAL NOTE:
AGRICULTURE IS THE PREFERRED USE IN THE AGRICULTURE ZONES. AGRICULTURE OPERATIONS AS SPECIFIED IN THE ZONING ORDINANCE FOR A PARTICULAR ZONE ARE PERMITTED AT ANY TIME INCLUDING THE OPERATION OF FARM MACHINERY AND NO ALLOWED AGRICULTURE USE SHALL BE SUBJECT TO RESTRICTION ON THAT IT INTERFERES WITH ACTIVITIES OF FUTURE RESIDENTS OF THIS SUBDIVISION.

NARRATIVE

THE PURPOSE OF THIS SURVEY WAS TO CREATE A FOURTEEN (14) LOT SUBDIVISION ON THE PROPERTY AS SHOWN AND DESCRIBED HEREON. THE SURVEY WAS ORDERED BY LEWIS HOMES. THE BASIS OF BEARING IS THE SOUTH LINE OF THE SOUTHWEST QUARTER OF SECTION 15, TOWNSHIP 7 NORTH, RANGE 1 EAST, OF THE SALT LAKE BASE AND MERIDIAN WHICH BEARS SOUTH 89°12'43" EAST WEBER COUNTY, UTAH NORTH, NAD 83 STATE PLANE GRID BEARING. THE RIGHT-OF-WAY OF FAIRWAYS DRIVE WAS ESTABLISHED BY HONORING THE EXISTING DEDICATED PLATS CONTAINING AND ADJOINING SAID FAIRWAYS DRIVE AND EXISTING DEED LINES.

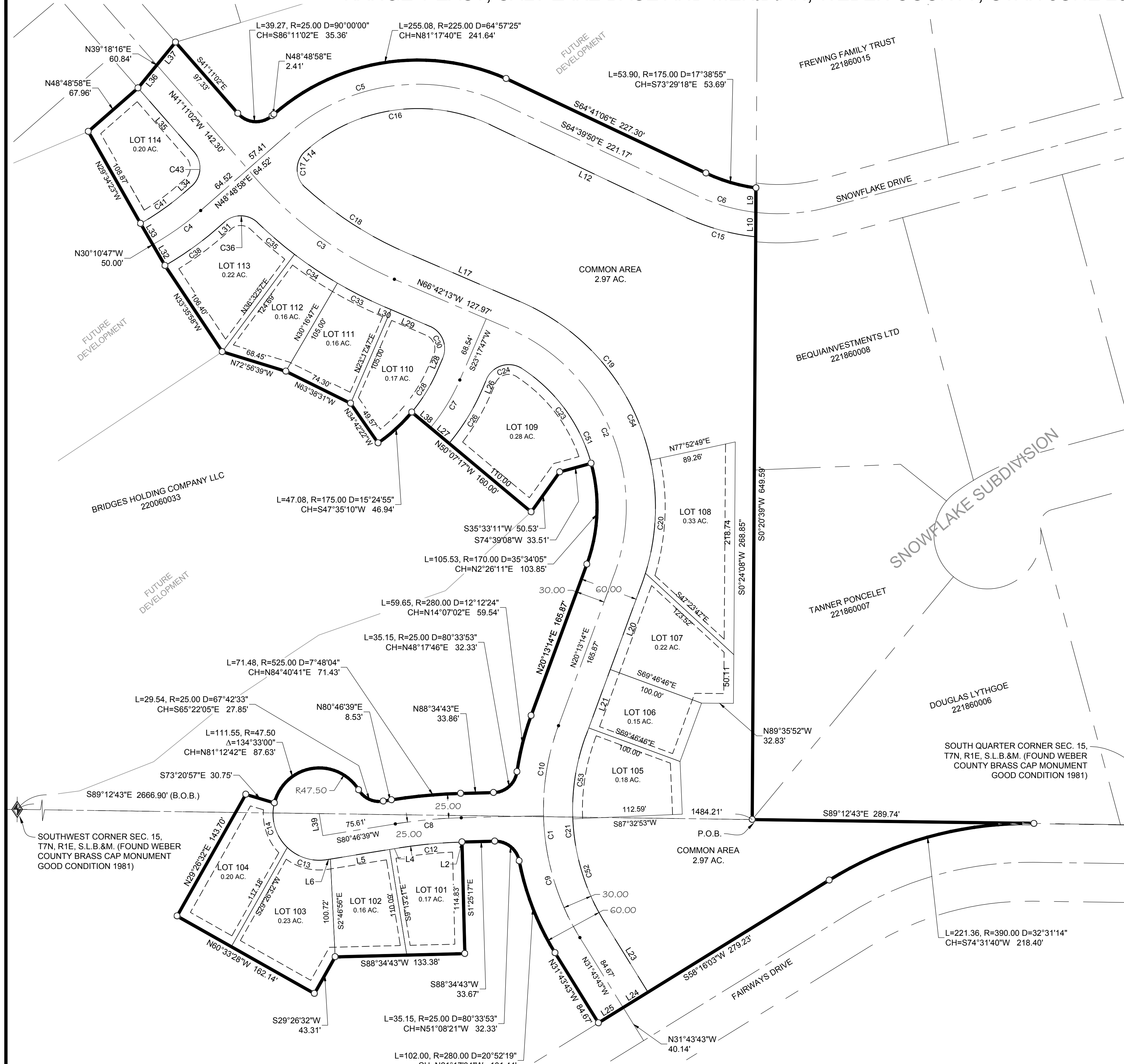

WEBER COUNTY SURVEYOR

I HEREBY CERTIFY THAT THE WEBER COUNTY SURVEYOR'S OFFICE HAS REVIEWED THIS PLAT FOR MATHEMATICAL CORRECTNESS, SECTION CORNER DATA, AND FOR HARMONY WITH LINES AND MONUMENTS ON RECORD IN COUNTY OFFICES. THE APPROVAL OF THIS PLAT BY THE WEBER COUNTY SURVEYOR DOES NOT RELIEVE THE LICENSED LAND SURVEYOR WHO EXECUTED THIS PLAT FROM THE RESPONSIBILITIES AND/OR LIABILITIES ASSOCIATED THEREWITH.

SIGNED THIS _____ DAY OF _____, 2016.

WEBER COUNTY ATTORNEY

I HAVE EXAMINED THE FINANCIAL GUARANTEE AND OTHER DOCUMENTS ASSOCIATED WITH THIS SUBDIVISION PLAT AND MY OPINION THEY CONFORM WITH THE COUNTY ORDINANCE APPLICABLE THERETO AND NOW IN FORCE AND EFFECT.

SIGNED THIS _____ DAY OF _____, 2016.

COUNTY ATTORNEY

WEBER COUNTY ENGINEER

I HEREBY CERTIFY THAT THE REQUIRED PUBLIC IMPROVEMENT STANDARDS AND DRAWINGS FOR THIS SUBDIVISION CONFORM WITH COUNTY STANDARDS AND THE AMOUNT OF THE FINANCIAL GUARANTEE IS SUFFICIENT FOR THE INSTALLATION OF THESE IMPROVEMENTS.

SIGNED THIS _____ DAY OF _____, 2016.

COUNTY ENGINEER

WEBER COUNTY COMMISSION ACCEPTANCE

THIS IS TO CERTIFY THAT THIS SUBDIVISION PLAT, THE DEDICATION OF STREETS AND OTHER PUBLIC WAYS AND FINANCIAL GUARANTEE OF PUBLIC IMPROVEMENTS ASSOCIATED WITH THIS SUBDIVISION THEREON ARE HEREBY APPROVED AND ACCEPTED BY THE COMMISSIONERS OF WEBER COUNTY, UTAH.

SIGNED THIS _____ DAY OF _____, 2016.

CHAIRMAN, WEBER COUNTY COMMISSION

WEBER COUNTY PLANNING COMMISSION APPROVAL

THIS IS TO CERTIFY THAT THIS SUBDIVISION WAS DULY APPROVED BY THE WEBER COUNTY PLANNING COMMISSION.

SIGNED THIS _____ DAY OF _____, 2016.

CHAIRMAN, WEBER COUNTY PLANNING COMMISSION

WEBER - MORGAN HEALTH DEPARTMENT

I do hereby certify that the soils, percolation rates, and site condition for this subdivision have been investigated by this office and are approved for on-site wastewater disposal systems.

This _____ day of _____, 2016

Director Weber-Morgan Health Department

DEVELOPER:
LEWIS HOMES
5577 EAST ELKHORN DRIVE
EDEN, UT 84310
801-430-1507

GARDNER ENGINEERING
CIVIL - LAND PLANNING
MUNICIPAL - LAND SURVEYING

5150 SOUTH 375 EAST OGDEN, UT
OFFICE: 801-476-0202 FAX: 801-476-0066

COUNTY RECORDER

ENTRY NO. _____ FEE PAID _____
FILED FOR AND RECORDED _____
AT _____ IN BOOK _____ OF OFFICIAL _____
RECORDS, PAGE _____, RECORDED _____
FOR _____
COUNTY RECORDER _____
BY: _____

PARKSIDE P.R.U.D. PHASE 1
 A PLANNED RESIDENTIAL UNIT DEVELOPMENT
 LOCATED IN THE NORTHWEST QUARTER OF SECTION 22,
 AND THE SOUTHWEST QUARTER OF SECTION 15,
 TOWNSHIP 7 NORTH, RANGE 1 EAST, SALT LAKE BASE AND MERIDIAN,
 WEBER COUNTY, UTAH
 JUNE 2016

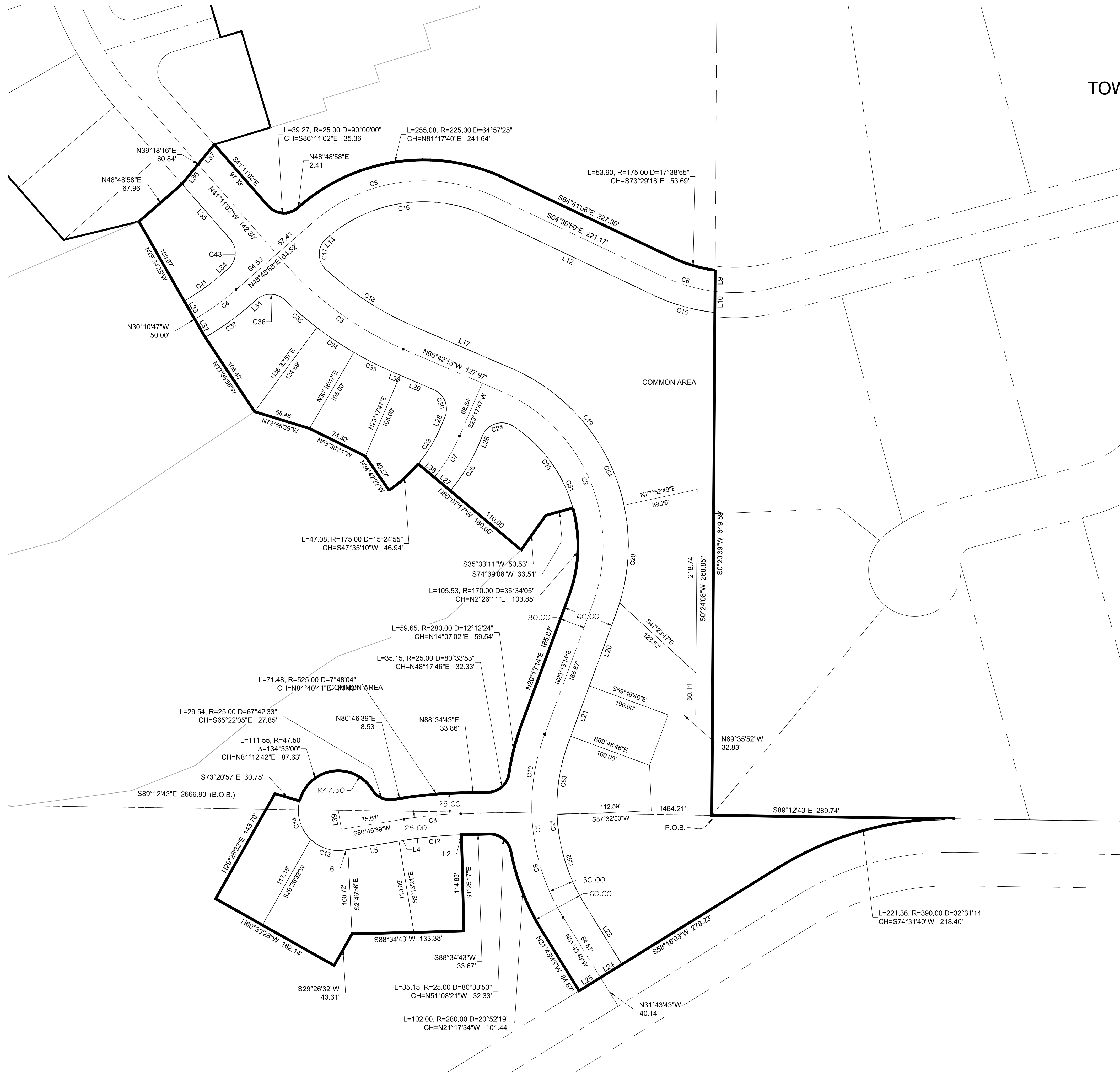

CURVE TABLE					
CURVE #	LENGTH	RADIUS	DELTA	CHORD BEARING	CHORD LI
C1	226.67	250.00	51.95	N5° 45' 15"W	218.99
C2	303.42	200.00	86.92	N23° 14' 30"W	275.15
C3	190.21	400.00	27.25	N53° 04' 51"W	188.42
C4	60.53	300.00	11.56	S54° 35' 46"W	60.43
C5	232.20	200.00	66.52	N82° 04' 34"E	219.38
C6	64.82	200.00	18.57	S73° 56' 57"E	64.54
C7	57.88	200.00	16.58	S31° 35' 15"W	57.68
C8	68.08	500.00	7.80	S84° 40' 41"W	68.02
C9	132.24	250.00	30.31	N16° 34' 30"W	130.70
C10	94.43	250.00	21.64	N9° 23' 58"E	93.87
C12	64.67	475.00	7.80	S84° 40' 41"W	64.62
C13	43.93	47.50	52.99	N72° 43' 34"W	42.38
C14	49.88	47.50	60.17	N16° 08' 48"W	47.62
C15	75.74	225.00	19.29	N74° 18' 26"W	75.38
C16	203.17	175.00	66.52	S82° 04' 34"W	191.95
C17	42.03	25.00	96.32	S0° 39' 30"W	37.25
C18	124.01	370.00	19.20	S57° 06' 06"E	123.43
C19	219.11	230.00	54.58	S39° 24' 42"E	210.92
C20	129.82	230.00	32.34	S4° 03' 01"W	128.11
C21	199.47	220.00	51.95	S5° 45' 15"E	192.71
C23	123.14	170.00	41.50	N36° 05' 58"W	120.47
C24	43.57	25.00	99.85	S73° 13' 22"W	38.26
C26	65.12	225.00	16.58	S31° 35' 15"W	64.89
C28	50.65	175.00	16.58	N31° 35' 15"E	50.47
C30	39.27	25.00	90.00	N21° 42' 13"W	35.36
C33	52.41	430.00	6.98	N63° 12' 43"W	52.38
C34	53.16	430.00	7.08	N56° 10' 44"W	53.12
C35	50.05	430.00	6.67	N49° 18' 11"W	50.02

LINE TABLE		
LINE #	LENGTH	BEARING
L2	0.19	S88° 34' 43"W
L4	10.03	S80° 46' 39"W
L5	61.74	S80° 46' 39"W
L6	3.84	S80° 46' 39"W
L9	25.18	S0° 20' 39"W
L10	25.14	S0° 20' 39"W
L12	221.17	N64° 39' 50"W
L14	0.50	S48° 48' 58"W
L17	127.97	S66° 42' 13"E
L20	93.27	S20° 13' 14"W
L21	72.60	S20° 13' 14"W
L23	84.67	S31° 43' 43"E
L24	30.00	S58° 16' 03"W
L25	30.00	S58° 16' 03"W
L26	11.40	S23° 17' 47"W
L27	25.00	N50° 07' 17"W
L28	13.54	N23° 17' 47"E
L29	43.63	N66° 42' 13"W
L30	9.15	N66° 42' 13"W
L31	10.93	S48° 48' 58"W

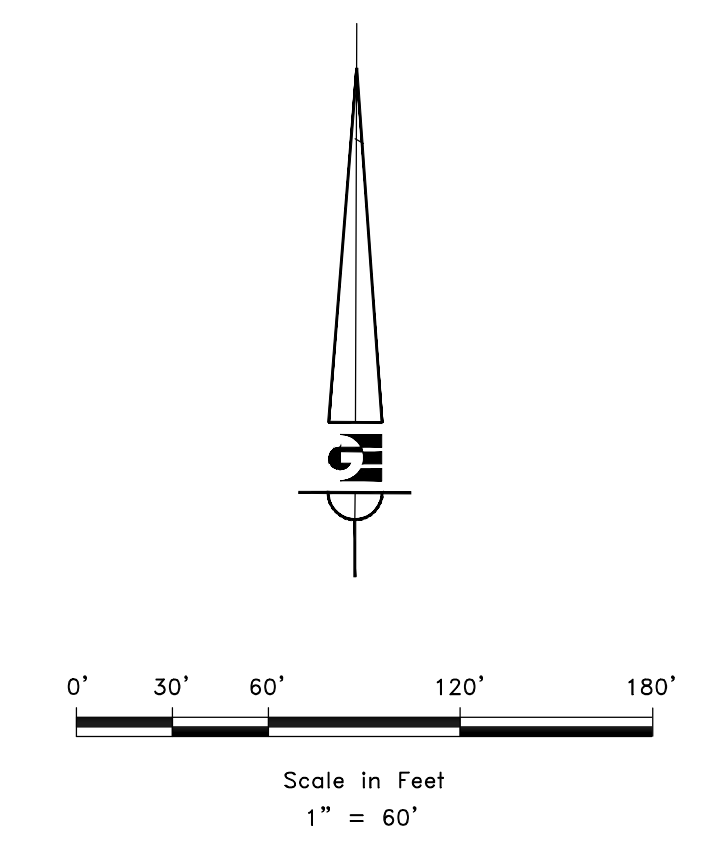

DEVELOPER: LEWIS HOMES 5577 EAST ELKHORN DRIVE EDEN, UT 84310 801-430-1507	S1 1	COUNTY RECORDER ENTRY NO. _____ FEE PAID _____
		FILED FOR AND RECORDED _____ AT _____ IN BOOK _____ OF OFFICIAL _____ RECORDS, PAGE _____, RECORDED _____ FOR _____ COUNTY RECORDER _____ BY: _____
 GARDNER ENGINEERING CIVIL - LAND PLANNING MUNICIPAL - LAND SURVEYING 5150 SOUTH 375 EAST OGDEN, UT OFFICE: 801.476.0202 FAX: 801.476.0066		

R:1201 - LEWIS HOMES THE BRIDGES SURVEY DWG/PARKSIDE PHASE 1.DWG