

East Lake Meadows Subdivision

Weber County, Utah

A Part of the Southeast Quarter of Section 17,
and A Part of the Southwest Quarter of Section 16,
Township 6 North, Range 2 East, Salt Lake Base & Meridian
March 2016

SURVEYOR'S CERTIFICATE

I, K. Greg Hansen, do hereby certify that I am a Registered Professional Land Surveyor in the State of Utah in Accordance with Title 58, Chapter 22, Professional Engineers and Land Surveyors Act; and I have Completed a Survey of the Property Described on this Plat in Accordance with Section 17-23-17 and have Verified all Measurements, and have Placed Monuments as Represented on this Plat, and have Hereby Subdivided said Tract into Five (5) Lots, Know Hereafter as East Lake Meadows in Weber County, Utah, and has been Correctly Drawn to the Designated Scale and its True and Correct Representation of the Herein Described Lands included in said Subdivision, Based Upon Data Compiled from Records in the Weber County Recorder's Office and from said Survey made by me on the Ground, I Further Hereby Certify that the Requirements of all Applicable Statutes and Ordinances of Weber County Concerning Zoning Requirements Regarding Lot Measurements have been Complied with.

Signed this _____ day of _____, 2016.

K. Greg Hansen P.L.S.
Utah Land Surveyor Licence No. 167819



BOUNDARY DESCRIPTION

A PART OF THE SOUTHWEST QUARTER OF SECTION 16 AND THE SOUTHEAST QUARTER SECTION 17, TOWNSHIP 6 NORTH, RANGE 2 EAST OF THE SALT LAKE BASE AND MERIDIAN.

BEGINNING AT THE INTERSECTION OF THE SOUTH RIGHT-OF-WAY LINE OF 500 SOUTH STREET AND THE EAST RIGHT-OF-WAY LINE OF 8600 EAST STREET BEING A POINT LOCATED 630.04 FEET NORTH 89°25'00" WEST AND 760.64 FEET SOUTH 00°35'00" WEST FROM THE EAST QUARTER CORNER OF SAID SECTION 17 BEING A WEBER COUNTY BRASS CAP MONUMENT;

RUNNING THENCE SOUTH 88°39'30" EAST 730.59 FEET ALONG THE SOUTH RIGHT-OF-WAY LINE OF 500 SOUTH STREET TO THE WEST BOUNDARY LINE OF MOUNTAIN VALLEY MEADOWS SUBDIVISION FILED AS ENTRY NO. 373528 IN THE FILES OF THE WEBER COUNTY RECORDER; THENCE ALONG SAID WEST BOUNDARY LINE THE FOLLOWING THREE (3) COURSES: (1) SOUTH 04°27'40" EAST 494.23 FEET; (2) SOUTH 08°25'40" EAST 206.66 FEET; AND (3) SOUTH 05°50'40" EAST 524.66 FEET TO THE NORTH BOUNDARY LINE OF RIVER RANCH FILED AS ENTRY NO. 1963391 IN THE FILES OF THE WEBER COUNTY RECORDER; THENCE SOUTH 66°15'20" WEST (SOUTH 65°58'00" WEST BY RECORD) 58.55 FEET ALONG SAID NORTH BOUNDARY LINE; THENCE SOUTH 79°33'11" WEST 161.00 FEET TO THE EAST LINE OF SAID SOUTHEAST QUARTER; THENCE NORTH 00°04'49" WEST 53.40 FEET ALONG SAID EAST LINE; THENCE NORTH 80°26'49" WEST 540.99 FEET TO THE EAST RIGHT-OF-WAY LINE OF 8600 EAST STREET; THENCE NORTH 07°46'48" WEST 191.05 FEET ALONG SAID EAST RIGHT-OF-WAY LINE TO AN EXISTING FENCE LINE BEING A POINT ON THE SOUTH BOUNDARY LINE OF THE JAMES L. ZELENICK PROPERTY FILED AS ENTRY NO. 2773943 IN THE FILES OF THE WEBER COUNTY RECORDERS OFFICE; THENCE ALONG THE BOUNDARY LINE OF SAID ZELENICK PROPERTY THE FOLLOWING FOUR (4) COURSES: (1) NORTH 84°37'59" EAST 192.95 FEET ALONG SAID FENCE LINE; (2) NORTH 08°26'37" WEST 311.80 FEET TO AN EXISTING FENCE LINE; (3) SOUTH 82°14'11" WEST 54.45 FEET ALONG AN EXISTING FENCE LINE; AND (4) SOUTH 84°58'28" WEST 141.83 FEET ALONG AN EXISTING FENCE LINE TO THE EAST RIGHT-OF-WAY LINE OF 8600 EAST STREET; THENCE NORTH 03°48'02" WEST 649.95 FEET ALONG SAID EAST RIGHT-OF-WAY LINE TO THE POINT OF BEGINNING, CONTAINING 19.02 ACRES.

NARRATIVE

The Purpose of this Survey was to Establish and set the Property Corners of the Three Lot Subdivision as Shown and Described Hereon. This Survey was Ordered by Jeff Hales. The POB for this Subdivision was determined using the Record Bearings and Distances of Carver Estates Subdivision. The Control used to Establish the Property Corners was the Existing Weber County Surveyor Monumentation Surrounding Section 36, Township 7 North, Range 3 West, S.L.B.&M. The basis of bearing is the South line of the Southwest Quarter of said Section which bears North 88°56'04" West, Utah North, State Plane, Calculated N.A.D.83 Bearing.

OWNER'S DEDICATION AND CERTIFICATION

Know all men by these presents that we, the undersigned Owners of the above described tract of land having caused the same to be subdivided into lots and streets, as shown on this plat and name said tract East Lake Meadows and hereby dedicate, grant and convey, in perpetuity, pursuant to the provisions of 17-27a-507, Utah code, without condition, restriction or reservation to Weber County, Utah, all those parts or portions of said tract of land designated as streets the same to be used as public thoroughfares forever, and also dedicate to Weber County those certain strips as easements for public utility and drainage purposes as shown hereon. The same to be used for the installation, maintenance and operation of public utility service lines and drainage as may be authorized by the Governing Authority in witness we have here unto set our signature this _____ day of _____, 2016.

Bradford J. Dobson

Amy M. Dobson

ACKNOWLEDGMENT

State of Utah
County of _____

On this _____ day of _____, 2016, Bradford J. Dobson and Amy M. Dobson, Husband and Wife as Joint Tenants, Personally Appeared before me, the Undersigned Notary Public in and for said County of _____ in the State of Utah, the Signers of the Attached Owners Dedication, Two in Numbers, who duly Acknowledged to me they Signed it Freely and Voluntarily and for the Purpose Therein Mentioned.

Notary Public

WEBER COUNTY RECORDER

ENTRY NO. _____ FEE PAID _____

FILED FOR RECORD AND

RECORDED _____

IN BOOK _____ OF OFFICIAL

RECORDS, PAGE _____ RECORDED

FOR _____

COUNTY RECORDER

BY: _____
DEPUTY

LEGEND

- Subject Property Line
- Interior Lot Line
- Secondary Property Line
- Centerline
- Easement
- Section Line
- Existing 5.0' Contour
- Existing 1.0' Contour
- Fence Line
- Power Line Existing
- Telephone Line Existing
- Gas Line Existing
- Edge of Asphalt Paving
- Irrigation Pipe
- Proposed 4" Irrigation Pipe
- FEMA Zone X
- Irrigation Box
- Telephone Pedestal
- Telephone Pedestal
- Power Pole
- Set 24"x5/8" Rebar with Cap
- Found rebar set by others
- Street Monument
- Section Corner

WEBER COUNTY ENGINEER

I hereby certify that the Required Public Improvement Standards and Drawings for this Subdivision Conform with the County Standards and the Amount of the Financial Guarantee is Sufficient for the Installation of these Improvements.

Signed this _____ Day of _____, 2016.

Weber County Engineer

WEBER COUNTY PLANNING COMMISSION APPROVAL

This is to Certify that this Subdivision Plat was Duly Approved by the Weber County Planning Commission.

Signed this _____ Day of _____, 2016.

Chairman, Weber County Planning Commission

Line No.	Bearing	Distance
L1	N 87°51'30" W	60.59'
L2	N 76°24'54" W	134.91'
L3	N 73°31'06" W	273.88'
L4	S 87°05'23" W	23.58'
L5	S 55°29'21" W	46.80'
L6	S 78°19'40" W	75.06'
L7	N 89°17'40" W	71.33'
L8	N 83°44'46" W	86.73'
L9	N 5°50'40" W	103.67'
L10	S 7°46'50" E	92.65'

- NOTES:
- ALL PUBLIC UTILITY EASEMENTS (PUE'S) ARE 10.00 FEET WIDE UNLESS NOTED OTHERWISE.
 - THE VERTICAL DATUM IS NAVD 88.
 - ALL CONSTRUCTION TO COMPLY WITH WEBER COUNTY CONSTRUCTION STANDARDS AND SPECIFICATIONS.

Developer:
Brad Dobson
bdobson@firstam.com
801-598-2459

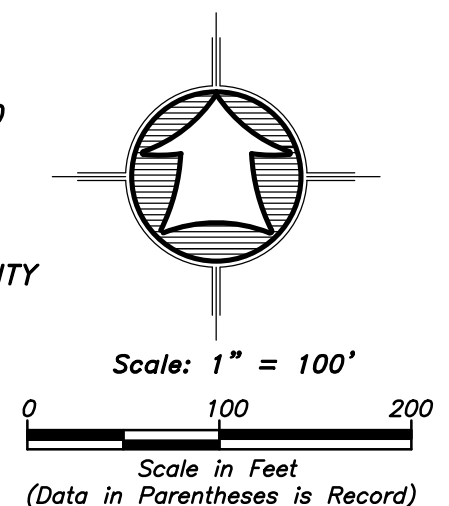

AGRICULTURAL NOTE

Agriculture is the preferred use in the Agriculture Zones. Agriculture operations as specified in the zoning ordinance for a particular zone are permitted at any time including the operation of farm machinery and no allowed agriculture use shall be subject to restriction on that it interferes with activities of future residents of this subdivision

WEBER COUNTY COMMISSION ACCEPTANCE

This is to Certify that this Subdivision Plat, the Dedication of Streets and other Public Ways and Financial Guarantee of Public Improvements Associated with this Subdivision, Thereon are Hereby Approved and Accepted by the Commissioners of Weber County Utah

Signed this _____ Day of _____, 2016.

Chairman, Weber County Commission

WEBER COUNTY SURVEYOR

I hereby certify that the Weber County Surveyor's Office has Reviewed this Plat for Mathematical Correctness, Section Corner Data, and for Harmony with the Lines and Monuments on Record in County Offices. The Approval of this Plat by the Weber County Surveyor does not Relieve the Licensed Land Surveyor who Executed this Plat from the Responsibilities and/or Liabilities Associated Therewith. Signed this _____ Day of _____, 2016.

Weber County Surveyor

WEBER COUNTY ATTORNEY

I have Examined the Financial Guarantee and Other Documents Associated with this Subdivision Plat, and in my Opinion they Conform with the County Ordinance Applicable Thereto and now in Force and Affect

Signed this _____ Day of _____, 2016.

Weber County Attorney

WEBER-MORGAN HEALTH DEPARTMENT

I hereby Certify that the Soils, Percolation Rates, and Site Conditions for this Subdivision have been Investigated by this Office and are Approved for On-Site Wastewater Disposal Systems.

Signed this _____ Day of _____, 2016.

Weber-Morgan Health Department