

MATCH LINE
SEE SHEET 2
42+00.00

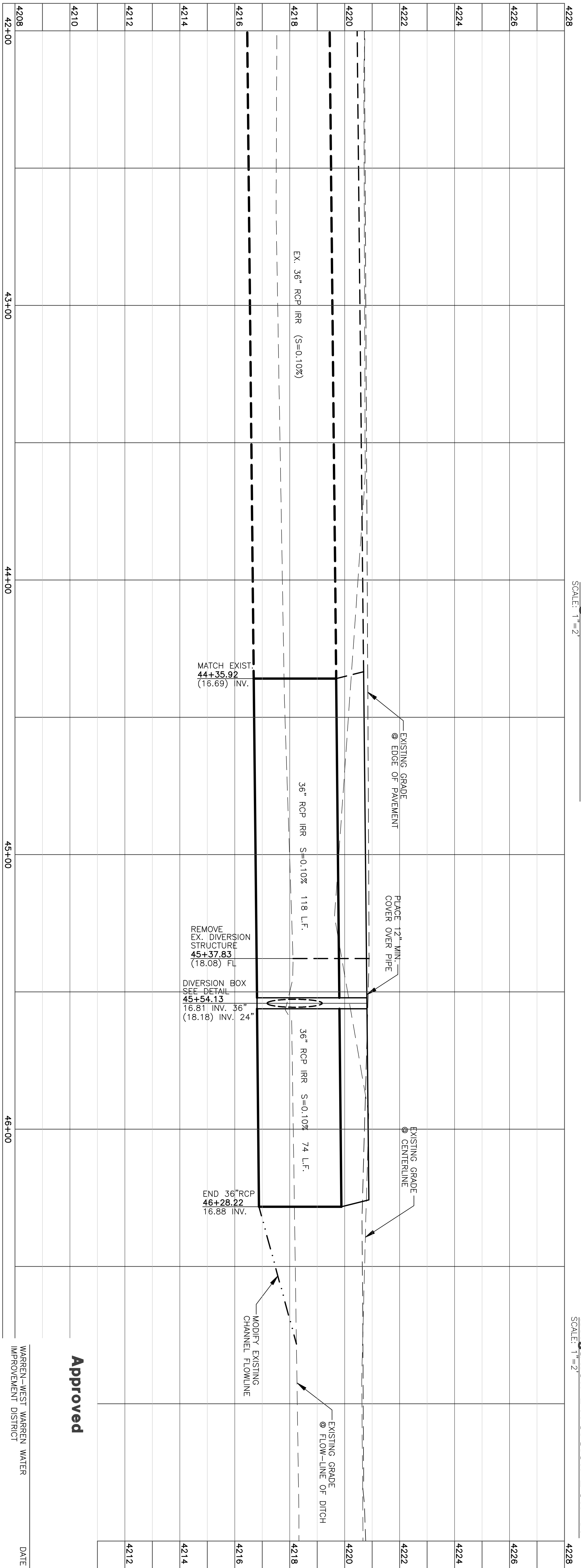
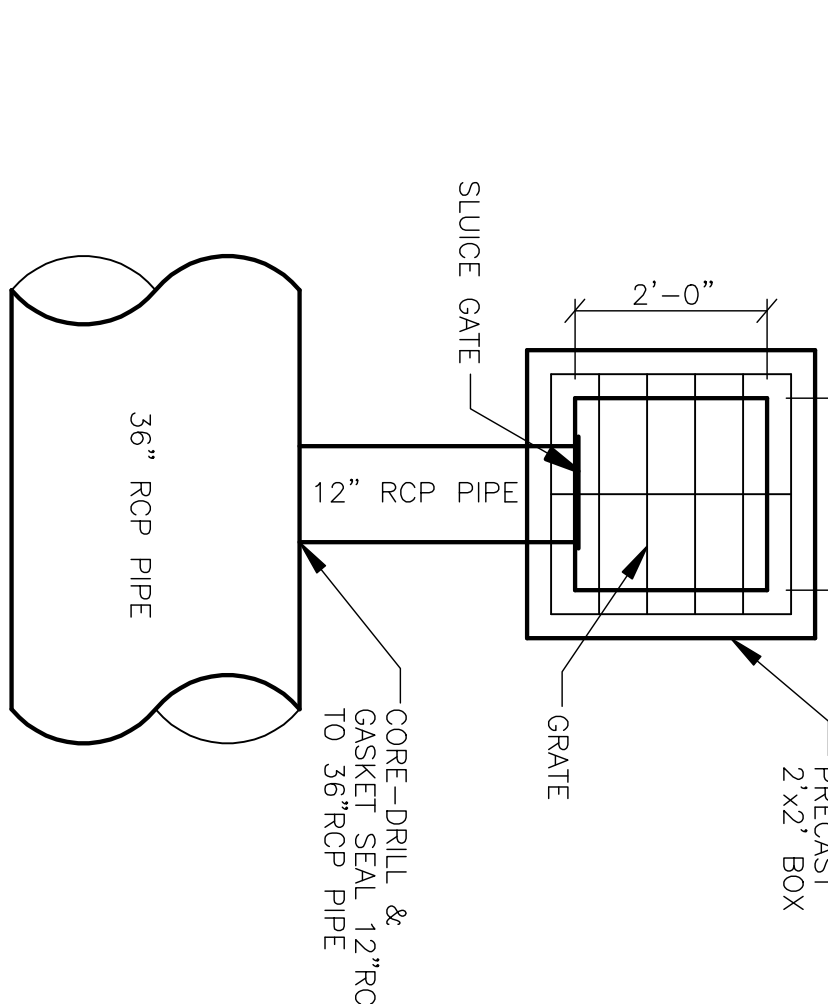
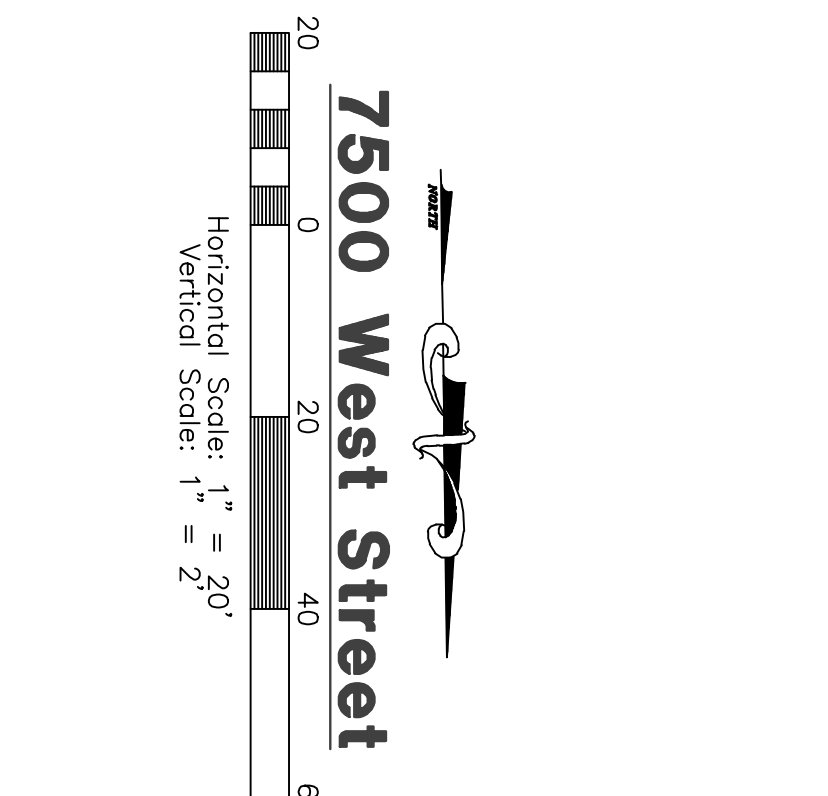
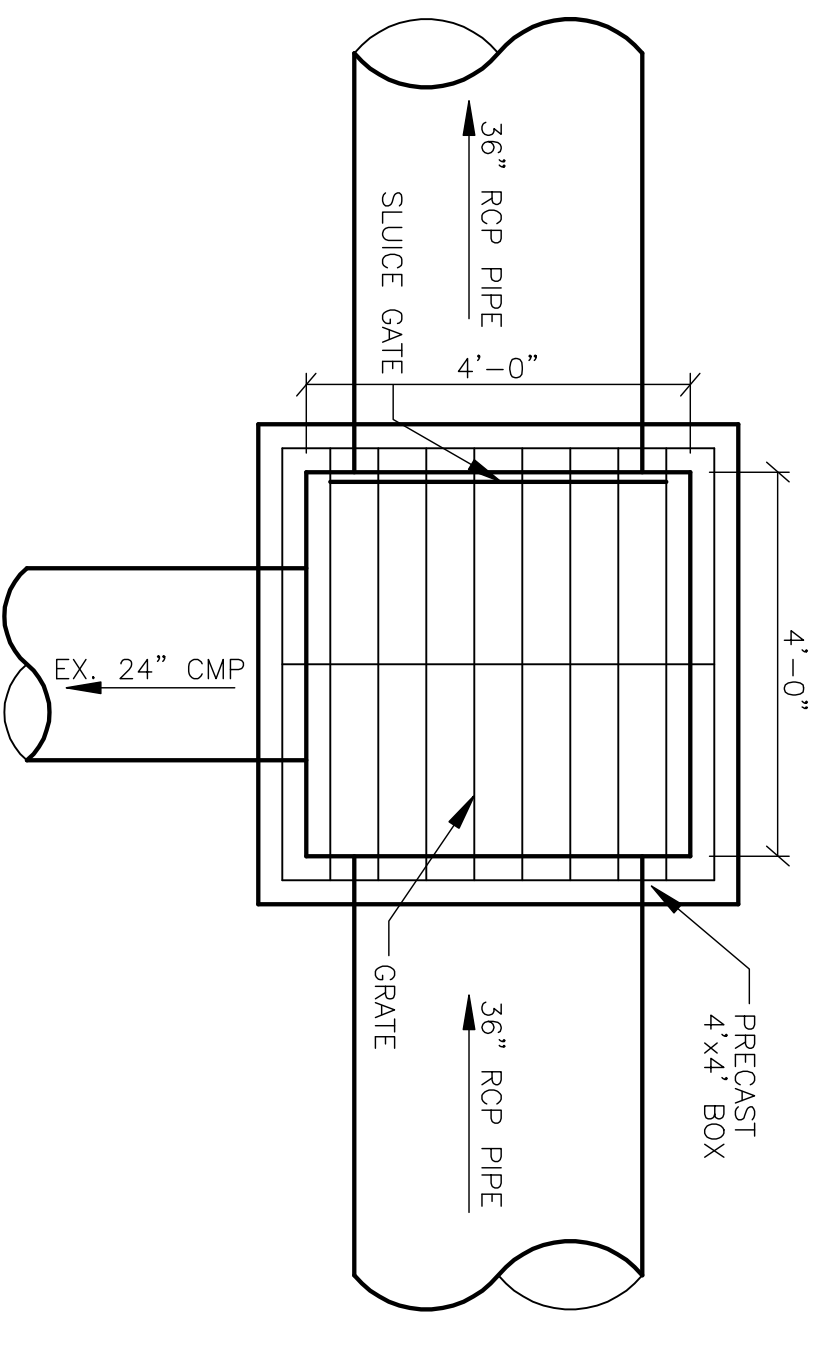
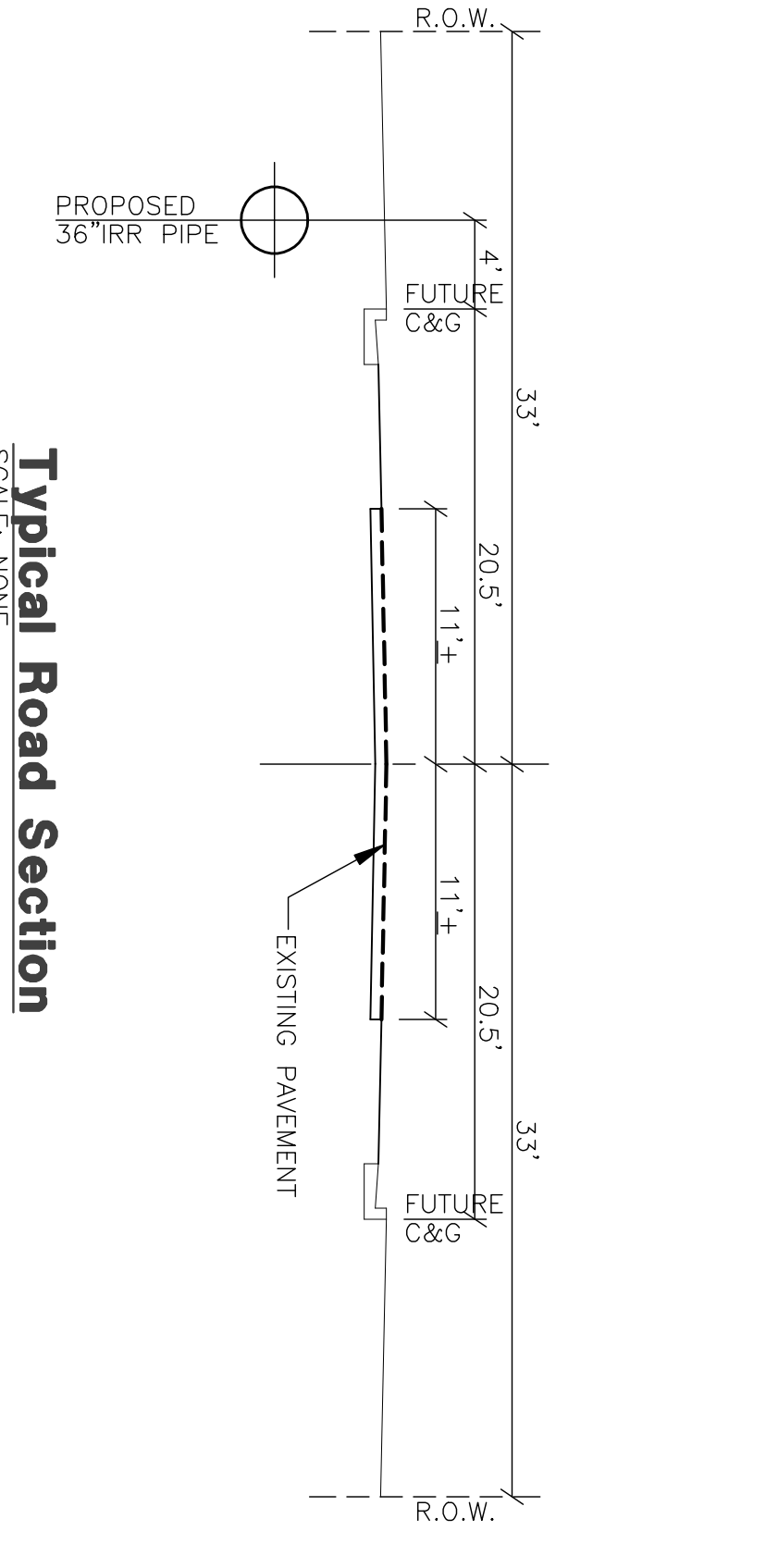
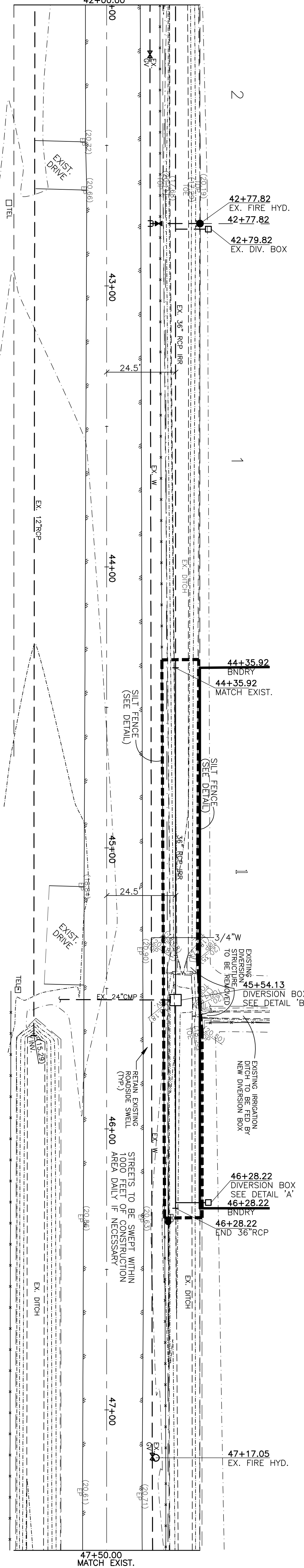

4228			
4226			
4224			
4222			
4220			
4218			
4216			
4214			
4212			
4210			
4208			
42+00			

Approved

WARREN-WEST WARREN WATER IMPROVEMENT DISTRICT DATE

Blue Sticks Location Center
Call: Toll Free 1-800-662-4111
Two Working Days Before You Dig

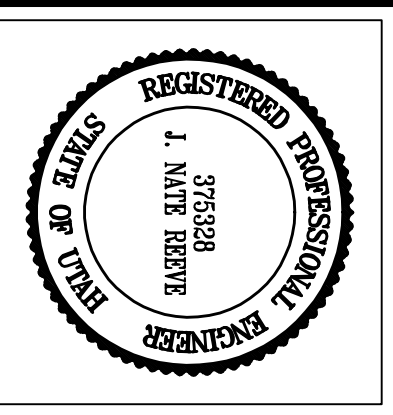

Lindsley Ranch Subdivision
WEBER COUNTY, UTAH

7500 West Street
42+00.00 - 47+50.00

REVISIONS	DATE	DESCRIPTION
	8-3-11	RH Added SWPPP
	8-4-11	RH County Comments

Reeve & Associates, Inc.
4155 S. HARRISON BLVD., SUITE 310, OGDEN, UTAH 84403
TEL: (801) 621-3100 FAX: (801) 621-2666 www.reeve-osroc.com
LAND PLANNERS • CIVIL ENGINEERS • LAND SURVEYORS
TRAFFIC ENGINEERS • STRUCTURAL ENGINEERS • LANDSCAPE ARCHITECTS

THESE PLANS AND SPECIFICATIONS ARE THE PROPERTY OF REEVE & ASSOCIATES, INC., 4155 S. HARRISON BLVD., OGDEN, UTAH 84403, AND SHALL NOT BE PHOTOCOPIED, RE-DRAWN, OR USED ON ANY PROJECT OTHER THAN THE PROJECT SPECIFICALLY DESIGNED FOR, WITHOUT THEIR WRITTEN PERMISSION. THE OWNERS AND ENGINEERS OF REEVE & ASSOCIATES, INC. DISCLAIM ANY LIABILITY FOR ANY CHANGES OR MODIFICATIONS MADE TO THESE PLANS OR THE DESIGN THEREON WITHOUT THEIR CONSENT.

Notes:

1. Describe all BMP's to protect storm water inlets:
All storm water inlets to be protected by straw wattle barriers, or gravel bogs (see detail).
2. Describe BMP's to eliminate/reduce contamination of storm water from:
 - a. Equipment / building / concrete wash areas:
To be performed in designated areas only and surrounded with silt fence barriers.
 - b. Soil contaminated by soil amendments:
If any contaminants are found or generated, contact environmental engineer and contacts listed.
 - c. Areas of contaminated soil:
If any contaminants are found or generated, contact environmental engineer and contacts listed.
 - d. Fueling areas:
To be performed in designated areas only and surrounded with silt fence.
 - e. Vehicle maintenance areas:
To be performed in designated areas only and surrounded with silt fence.
 - f. Vehicle parking areas:
To be performed in designated areas only and surrounded with silt fence.
 - g. Equipment storage areas:
To be performed in designated areas only and surrounded with silt fence.
 - h. Material storage areas:
To be performed in designated areas only and surrounded with silt fence.
 - i. Waste containment areas:
To be performed in designated areas only and surrounded with silt fence.
 - j. Service areas:
To be performed in designated areas only and surrounded with silt fence.
3. BMP's for wind erosion:
Stockpiles and site as needed to be watered regularly to eliminate / control wind erosion
4. Construction Vehicles and Equipment:
 - a. Monitor all construction equipment to prevent oil or other fluid leaks.
 - Keep vehicles and equipment clean, prevent excessive build-up of oil and grease.
 - Regularly inspect on-site vehicles and equipment for leaks, and repair immediately.
 - Check incoming vehicles and equipment (including delivery trucks, and employee and subcontractor vehicles) for leaking oil and fluids. Do not allow leaking vehicles or equipment on-site.
 - Segregate and recycle wastes, such as greases, used oil or oil filters, antifreeze, cleaning solutions, automotive batteries, hydraulic, and transmission fluids.
 - b. Fueling
 - If fueling must occur on-site, use designated areas away from drainage.
 - Use drip pans to catch spills or leaks from the tank volume.
 - Cover retention area with an impervious material and install in a manner to ensure that any spills will be contained in the retention area. To catch spills or leaks when removing or changing fluids.
 - Use drip pans for any oil or fluid changes.
 - c. Washing
 - Use as little water as possible to avoid installing erosion and sediment controls for the wash area.
 - If washing must occur on-site, use designated, bermed wash areas to prevent waste water discharge into storm water, creeks, rivers, and other water bodies.
 - Use phosphate-free, biodegradable soaps.
 - Do not permit steam cleaning on-site.
5. Spill Prevention and Control
 - a. Minor Spills:
Minor spills are those which are likely to be controlled by on-site personnel. After contacting local emergency response agencies, the following actions should occur upon discovery of a minor spill:
 - Contain the spread of the spill.
 - If the spill occurs on paved or impermeable surfaces, clean up using "dry" methods (i.e. absorbent materials, cat litter, and / or rags).
 - If the spill occurs in dirt areas, immediately contain the spill by constructing an earth dike. Dig up property dispose of contaminated soil, cover the impacted area to avoid runoff.
 - Record all steps taken to report and contain spill.
 - b. Major Spills:
On-site personnel should not attempt to control major spills until the appropriate and qualified emergency response staff have arrived at the site. For spills of federal reportable quantities, also notify the National Response Center at (800) 424-8802. A written report should be sent to all notified authorities. Failure to report major spills can result in significant fines and penalties.
6. Post Roadway / Utility Construction
 - a. Maintain good housekeeping practices.
 - b. Probe or cover building material storage areas.
 - c. Store dry and wet materials under cover, away from drainage areas.
 - d. Avoid mixing excess amounts of fresh concrete or cement on-site.
 - e. Perform washout of concrete trucks offsite or in designated areas only.
 - f. Do not wash out concrete trucks into storm drains, open ditches, streets or streams.
 - g. Do not place material or debris into streams, gutters or catch basins that stop or reduce the flow of runoff water.
 - h. All public streets and storm drain facilities shall be maintained free of building materials, mud and debris if necessary, within 1000' of construction entrance daily.
 - i. Install storm water development.
 - j. Install storm water development.
7. Erosion Control Plan Notes
 - a. The contractor will designate an emergency contact that can be reached 24 hours a day 7 days a week.
 - b. A stand-by crew for emergency work shall be available at all times during potential rain or snow runoff events. Necessary materials shall be available on site and stockpiled at convenient locations to facilitate rapid construction of emergency devices when rain or runoff is eminent.
 - c. Erosion control devices shown on the plans and approved for the project may not be removed without approval of the engineer of record. If devices are removed, no work may continue that requires protection. The person without consulting the engineer of record shall be held responsible for any erosion control devices that are removed. The person without consulting the engineer of record shall be held responsible for any erosion control devices that are removed. The person without consulting the engineer of record shall be held responsible for any erosion control devices that are removed.
 - d. Graded areas adjacent to fill slopes located at the site perimeter must drain away from the top of the slope of the conclusion of each working day. This should be confirmed by survey or other means acceptable to the engineer of record.
 - e. All silt and debris shall be removed from all devices within 24 hours after each rain or runoff event.
 - f. Except as otherwise approved by the inspector, all removable protective devices shown shall be in place at the end of each working day and through weekends until removal of the system is approved.
 - g. All loose soil and debris, which may create a potential hazard to offsite property, shall be removed from the site as directed by the Engineer of record or the governing agency.
 - h. The placement of additional devices to reduce erosion damage within the site is left to the discretion of the Engineer of record.
 - i. Desilting basins may not be removed or made inoperable without the approval of the engineer of record and the governing agency.
 - j. Erosion control devices will be modified as needed as the project progresses, and plans of these changes submitted for approval by the engineer of record and the governing agency.
8. Conduct a minimum of one inspection of the erosion and sediment controls every two weeks. Maintain documentation on site.
 - a. Part III.D.4 of general permit UTRR300000 identifies the minimum inspection requirements.
 - b. Part III.D.4.C identifies the minimum inspection report requirements.
 - c. Failure to complete and/or document storm water inspections is a violation of part III.D.4 of Utah General Permit UTR 3000000.

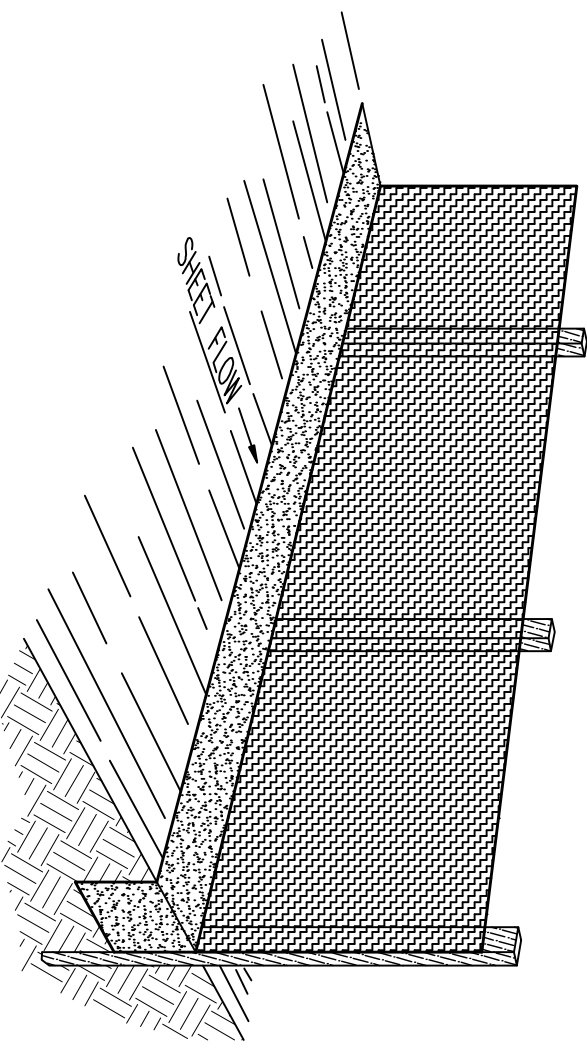

Perspective View

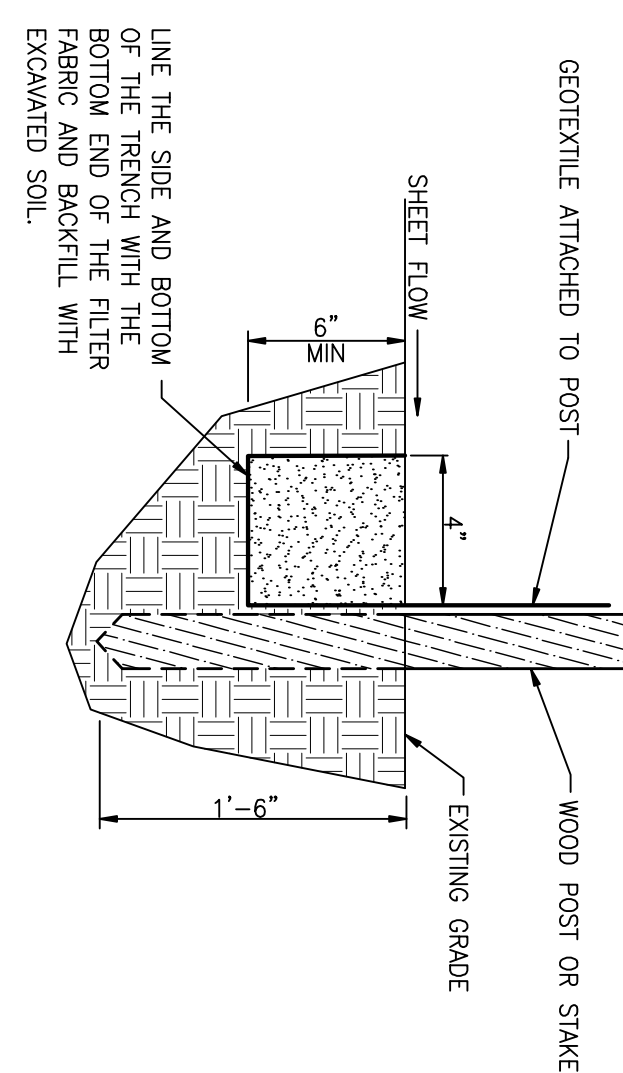

Section

INSTALLATION
The silt fence should be installed prior to major soil disturbances in the drainage area. The fence should be placed across the slope along a line of uniform elevation wherever flow of sediment is anticipated. Table 1 shows generally-recommended spacing between silt fence rolls for most silt fence applications.

Slope Steepness (%)	Max. Slope Length m (ft)
<2%	30.5m (100ft)
2-5%	22.9m (75ft)
5-10%	15.2m (50ft)
10-20%	7.6m (25ft)
>20%	4.3m (15ft)

PREFABRICATED SILT FENCE ROLLS
Fabricate a minimum 15.2cm x 15.2cm (6"x6") trench at the desired location.
*Unroll the silt fence, positioning the post against the downstream wall of the trench.
*Adjacent rolls of silt fence should be joined by nesting the end post of one fence into the nesting slot of the other.
*Rotate each post until the geotextile is wrapped completely around the post, then about the end post to create a tight seal as shown in Figure 1.
*Drive posts into the ground until the required fence height and/or anchorage depth is achieved.
*bury the loose geotextile at the bottom of the fence in the upstream trench and backfill with natural soil, tamping the backfill to provide good compaction and anchorage. Figure 2 illustrates a typical silt fence installation and anchor trench placement.

FIELD ASSEMBLY:
*Excavate a minimum 15.2cm x 15.2cm (6"x6") trench at the desired location.
*Drive wooden posts, or steel posts with fastening projections, against the downstream wall of the trench. Maximum post spacing should be 2.4-3.0m (8-10ft). Post spacing

Silt Fence Detail

SCALE: NONE

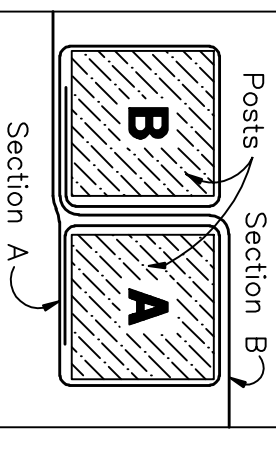

Figure 1:
Top View of Roll-to-Roll Connection

should generally be less than three (3) times the height of the fence.
*If a steel or plastic mesh is required to reinforce the geotextile, it shall have a minimum mesh opening of 13.2cm (6").
*The mesh shall be installed on the upstream side of the posts using heavy duty wire staples. The wires or hog strings. Extend the mesh into the bottom of the trench.
*The geotextile shall then be stapled or wired to the posts. An extra 20-50cm (8-20") of geotextile shall extend into the trench.

INSPECTION
*Inspect the silt fence daily during periods of rainfall, immediately after significant rainfall event and weekly during periods of no rainfall. Make any repairs immediately.
*When sediment deposits behind the silt fence are one-third of the fence height, remove the sediment. When sediment deposits are one-half of the fence height, remove the sediment. Avoid damage to the fabric during cleanout.

REMOVAL
*Silt fence should not be removed until construction ceases and the upslope area has been properly stabilized and/or revegetated.

THESE PLANS AND SPECIFICATIONS ARE THE PROPERTY OF REEVE & ASSOCIATES, INC., 4155 S. HARRISON BLVD., EXCISE BLDG. #310, OGDEN, UTAH 84403, AND SHALL NOT BE PHOTOCOPIED, RE-DRAWN, OR USED ON ANY PROJECT OTHER THAN THE PROJECT SPECIFICALLY DESIGNED FOR, WITHOUT THEIR WRITTEN PERMISSION. THE OWNERS AND ENGINEERS OF REEVE & ASSOCIATES, INC. DISCLAIM ANY LIABILITY FOR ANY CHANGES OR MODIFICATIONS MADE TO THESE PLANS OR THE DESIGN THEREON WITHOUT THEIR CONSENT.

Reeve & Associates, Inc.
4155 S. HARRISON BLVD., SUITE 310, OGDEN, UTAH 84403
TEL: (801) 621-3100 FAX: (801) 621-2666 www.reeve-associ.com
LAND PLANNERS • CIVIL ENGINEERS • LAND SURVEYORS
TRAFFIC ENGINEERS • STRUCTURAL ENGINEERS • LANDSCAPE ARCHITECTS

REVISIONS	DATE	DESCRIPTION
	8-3-11	RH Added SWPPP
	8-4-11	RH County Comments

Lindsley Ranch Subdivision
WEBER COUNTY, UTAH

Storm Water Pollution Prevention Plan Details

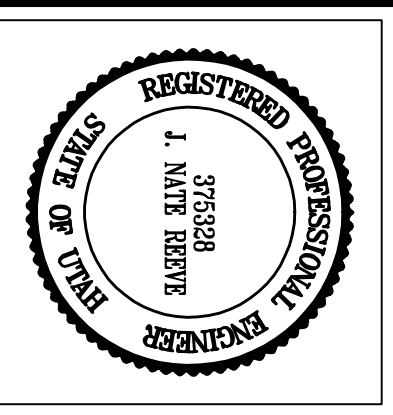

Project Info.
Engineer: J. NATE REEVE, P.E.
Drafter: R. HANSEN
Begin Date: JULY 19, 2011
Name: LINDSLEY RANCH SUBDIVISION
Number: 5363-01

Sheet	2
Sheets	2