

NOTE:

- EACH CONDOMINIUM UNIT CONTAINED WITHIN THE PROJECT IS AS SHOWN AND IS DESIGNATED BY A NUMBER.
COMMON AREAS AND FACILITIES - PRIVATE OWNERSHIP - LIMITED COMMON AREAS AND FACILITIES -
- ALL DRIVEWAYS, PATIOS, DECKS, BALCONIES, ON EACH UNIT CONTAINED WITHIN THE PROJECT ARE CONSIDERED LIMITED COMMON AREAS. THEY ARE SET ASIDE AND RESERVED FOR THE USE OF THE RESPECTIVE CONDOMINIUM UNIT TO WHICH THEY ARE ATTACHED OR APPURTENANT.
- ALL OTHER AREAS CONTAINED WITHIN THE PROJECT, BUT NOT SHOWN WITH DIAGONAL STRIPE OR CROSS HATCHED LINES ARE CONSIDERED COMMON AREA, INCLUDING COVERED AND UNCOVERED PARKING, PRIVATE STREETS, PUBLIC UTILITY, STORM WATER DETENTION AND DRAINAGE EASEMENT AREA. COMMON AREAS ARE "TO BE USED FOR RECREATIONAL AND OPEN SPACE PURPOSES FOR THE BENEFIT OF EACH OWNERS ASSOCIATION MEMBER IN COMMON WITH ALL OTHERS IN THE CONDOMINIUM AND GRANT AND DEDICATE TO WEBER COUNTY A PERPETUAL OPEN SPACE RIGHT AND EASEMENT ON AND OVER THE COMMON AREA TO GUARANTEE TO WEBER COUNTY THAT THE COMMON AREAS REMAIN OPEN AND UNDEVELOPED EXCEPT FOR APPROVED RECREATIONAL, PARKING AND OPEN SPACE PURPOSES.
- DIMENSIONS ON THIS SHEET ARE TO EXTERIOR FOUNDATION ONLY.
- ALL COMMON AREA, INCLUDING THE PRIVATE STREETS, IS CONSIDERED TO BE AN EASEMENT FOR PUBLIC UTILITY AND DRAINAGE PURPOSES.
- EIGHT INCH CULINARY WATERLINE AND THE SANITARY SEWER MAIN TO BE PRIVATELY OWNED AND MAINTAINED BY THE HOME OWNER'S ASSOCIATION.
- THERE ARE NO CONVERTIBLE OR WITHDRAWALABLE AREAS IN THIS CONDOMINIUM PHASE.
 - OFFSITE WATERLINE EASEMENT BENEFITING THIS CONDOMINIUM PHASE REF. ENTRY E#2518068.
 - OFFSITE SEWER EASEMENT BENEFITING THIS CONDOMINIUM PHASE REF. ENTRY E#2522491.
 - OFFSITE WATERLINE EASEMENT BENEFITING THIS CONDOMINIUM PHASE REF. ENTRY E#2518068.
 - IRRIGATION DITCH EASEMENT BURDENING THIS CONDOMINIUM PHASE REF. BK 845 PG 638.
 - ALL ACRESAGES ON THE DRAWING REFLECT TOTALS AFTER ROAD DEDICATIONS.
 - OFFSITE POWER EASEMENT BENEFITING THIS CONDOMINIUM PHASE REF. ENTRY E#2523246.
 - POWER EASEMENT BENEFITING THE CONDOMINIUM PHASE REF. ENTRY E#2522813.
 - DRAINAGE EASEMENT BENEFITING THE CONDOMINIUM PHASE REF. ENTRY E#2522492.

EDGEWATER BEACH RESORT PHASE 1

A CONDOMINIUM PLAT

A PART OF THE SOUTHWEST QUARTER OF SECTION 13, TOWNSHIP 6 NORTH, RANGE 1 EAST WEBER COUNTY UTAH

SHEET 1 OF 3
JANUARY 2010

NARRATIVE

THIS CONDOMINIUM PLAT WAS REQUESTED BY CELTIC BANK IN ORDER TO BUILD A CONDOMINIUM PROJECT. A LINE BEARING SOUTH 89°36'57" EAST BETWEEN THE BRASS CAP MONUMENTS FOUND AT THE SOUTHWEST CORNER AND THE SOUTH QUARTER CORNER OF SECTION 13, T6N, R1E, WAS USED AS THE BASIS OF BEARINGS. LOT CORNERS WERE MONUMENTED AS DEPICTED ON THIS DRAWING.

CURVE DATA

- (1)
 $\Delta = 1'50'21"$
 $R = 1859.86'$
 $L = 59.70'$
 $CB = S71'39'06"E$
 $LC = 59.69'$
- (A)
 $\Delta = 4'05'46"$
 $R = 362.85'$
 $L = 25.94'$
 $CB = N6'52'59"W$
 $LC = 25.93'$
- (B)
 $\Delta = 7'22'02"$
 $R = 124.50'$
 $L = 16.01'$
 $CB = S5'14'51"W$
 $LC = 16.00'$
- (C)
 $\Delta = 25'50'41"$
 $R = 74.99'$
 $L = 33.83'$
 $CB = S11'21'26"E$
 $LC = 33.54'$
- (D)
 $\Delta = 43'43'21"$
 $R = 130.00'$
 $L = 99.20'$
 $CB = S46'08'22"E$
 $LC = 96.81'$
- (E)
 $\Delta = 4'32'51"$
 $R = 1015.00'$
 $L = 80.56'$
 $CB = S70'16'28"E$
 $LC = 80.54'$
- (F)
 $\Delta = 3'22'27"$
 $R = 1015.00'$
 $L = 59.77'$
 $CB = S 69'41'16" E$
 $LC = 59.76'$
- (G)
 $\Delta = 1'10'25"$
 $R = 1015.00'$
 $L = 20.79'$
 $CB = S 71'57'41" E$
 $LC = 20.79'$

CENTERLINE CURVE DATA

- (A)
 $\Delta = 4'05'46"$
 $R = 362.85'$
 $L = 25.94'$
 $CB = N6'52'59"W$
 $LC = 25.93'$
- (B)
 $\Delta = 7'22'02"$
 $R = 124.50'$
 $L = 16.01'$
 $CB = S5'14'51"W$
 $LC = 16.00'$
- (C)
 $\Delta = 25'50'41"$
 $R = 74.99'$
 $L = 33.83'$
 $CB = S11'21'26"E$
 $LC = 33.54'$
- (D)
 $\Delta = 43'43'21"$
 $R = 130.00'$
 $L = 99.20'$
 $CB = S46'08'22"E$
 $LC = 96.81'$
- (E)
 $\Delta = 4'32'51"$
 $R = 1015.00'$
 $L = 80.56'$
 $CB = S70'16'28"E$
 $LC = 80.54'$
- (F)
 $\Delta = 3'22'27"$
 $R = 1015.00'$
 $L = 59.77'$
 $CB = S 69'41'16" E$
 $LC = 59.76'$
- (G)
 $\Delta = 1'10'25"$
 $R = 1015.00'$
 $L = 20.79'$
 $CB = S 71'57'41" E$
 $LC = 20.79'$

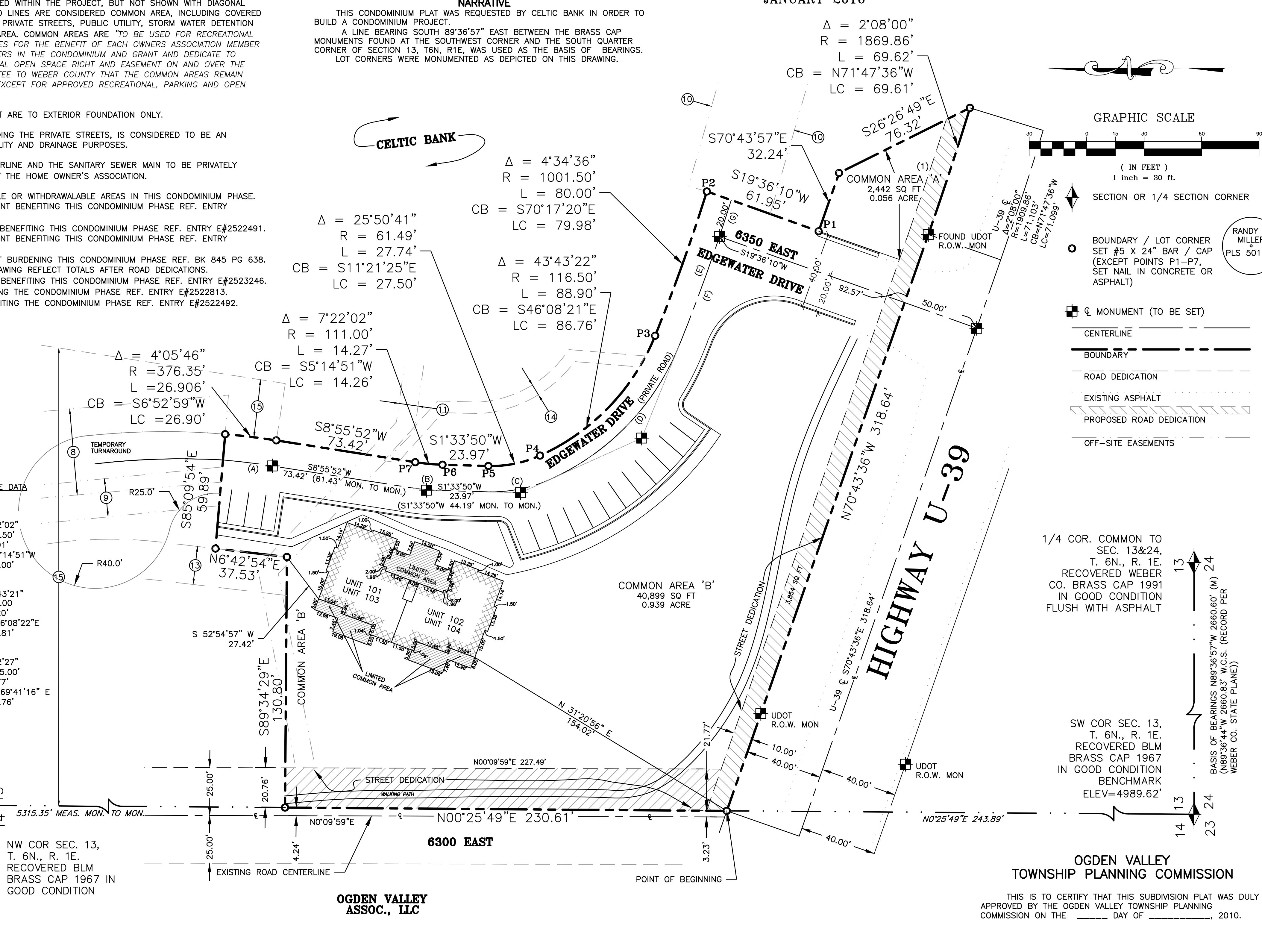

OWNER'S DEDICATION AND CONSENT TO RECORD

Know all men by these presents: Celtic Bank, which is the owner of the tract of land described hereon and Edgewater Beach Resort Phase 1, a condominium project located on said tract of land, do hereby make this certificate for and on behalf of said corporation and have caused; 1. a survey to be made and 2. this condominium plat, consisting of three (3) sheets to be prepared. Said Celtic Bank has consented and does hereby consent to the recording of this condominium plat in accordance with the Utah Condominium Ownership Act; We the undersigned owners of the herein described tract of land, do hereby set apart and subdivide the same into lots and streets (Private Streets, Private Rights-of-Way) as shown hereon and name said tract **EDGEWATER BEACH RESORT PHASE 1**, and do hereby:

Dedicate to public use all those parts or portions of said tract of land designated as streets, the same to be used as public thoroughfares. Dedicate and reserve unto themselves, their heirs, their grantees and assigns, a right-of-way to be used in common with all others within said subdivision (and those adjoining subdivisions that may be subdivided by the undersigned owners, their successors, or assigns) on, over and across all those portions or parts of said tract of land designated on said plat as Private Streets (Private Rights-of-Way) as access to the individual lots, to be maintained by a Lot (unit) Owners Association whose membership consists of said owners, their grantees, successors, or assigns. Grant and convey to the subdivision Lot (unit) Owners Association, all those parts or portions of said tract of land designated as Common Areas to be used for recreational and open space purposes for the benefit of each Lot (unit) Owners Association member in common with all others in the subdivision and grant and dedicate to Weber County a perpetual Open Space Right and Easement on and over the Common Areas to guarantee to Weber County that the Common Areas remain open and undeveloped except for approved recreational, parking and open space purposes. Grant and dedicate a perpetual right and easement over, upon and under the lands designated hereof as public utility, storm water detention ponds drainage easements and canal maintenance easement, the same to be used for the installation maintenance and operation of public utility service line, storm drainage facilities, irrigation canals or for the perpetual preservation of water channels in their natural state whichever is applicable as may be authorized by the governing authority, with no buildings or structures being erected within such easements. Grant and dedicate unto all owners of lots upon which private land drains are constructed or which are otherwise dependent upon such land drains, an easement over such land drains for the purpose of perpetual maintenance and operation. Dedicate, grant and convey to Weber County, Utah, or its designee, all those parts or portions of said tract of land designated as parks the same to be used as public open space. All common area, including the private streets, is considered to be an easement for public utility and drainage purposes.

In Witness whereof I have set my hand and affixed the Corporate seal this ____ day of _____, 2010.

CELTIC BANK
BRADLEY BYBEE, CHIEF LENDING OFFICER

ACKNOWLEDGEMENTS

On the ____ day of _____, 2010, personally appeared before me, the undersigned Notary Public, the signer of the above Owner's Dedication, one in number who duly acknowledged to me he signed it freely and voluntarily and for the purposes therein mentioned.

Residing at: _____
A Notary Public Commissioned in Utah

Commission Expires: _____
Print Name

State of }
County of } ss

On the ____ day of _____, 2010, personally appeared before me, the undersigned Notary Public, the signer of the above Owner's Dedication, one in number who duly acknowledged to me he signed it freely and voluntarily and for the purposes therein mentioned.

Residing at: _____
A Notary Public Commissioned in Utah

Commission Expires: _____
Print Name

State of }
County of } ss

SURVEYOR'S CERTIFICATE

I, RANDY N. MILLER, DO HEREBY CERTIFY THAT I AM A PROFESSIONAL LAND SURVEYOR IN THE STATE OF UTAH IN ACCORDANCE WITH TITLE 58, CHAPTER 22, PROFESSIONAL ENGINEERS AND LAND SURVEYORS ACT; AND THAT I HAVE COMPLETED A SURVEY OF THE PROPERTY DESCRIBED ON THIS PLAT IN ACCORDANCE WITH SECTION 17-23-17 AND HAVE VERIFIED ALL MEASUREMENTS, AND HAVE PLACED MONUMENTS AS REPRESENTED ON THIS PLAT, AND THAT THIS PLAT OF EDGEWATER BEACH RESORT PHASE 1 IN WEBER COUNTY, UTAH HAS BEEN DRAWN CORRECTLY TO THE DESIGNATED SCALE AND IS A TRUE AND CORRECT REPRESENTATION OF THE HEREIN DESCRIBED LANDS INCLUDED IN SAID SUBDIVISION, (BASED UPON DATA COMPILED FROM RECORDS IN THE WEBER COUNTY RECORDER'S OFFICE AND FROM SAID SURVEY MADE BY ME ON THE GROUND). I FURTHER CERTIFY THAT THE REQUIREMENTS OF ALL APPLICABLE STATUTES AND ORDINANCES OF WEBER COUNTY CONCERNING ZONING REQUIREMENTS REGARDING LOT MEASUREMENTS HAVE BEEN COMPLIED WITH. 6300 EAST IS BEING RE-DEDICATED OVER THE TOP OF AN EXISTING ACTION TO CREATE MULTIPLE 66 FOOT WIDE COUNTY ROADS. PER THE COUNTY SURVEYOR'S DIRECTION AND DESIRE, THE LIMITS OF 6300 EAST WERE CONSTRUCTED AS 33 FEET LEFT AND RIGHT OF THE APPARENT CENTERLINE OF THE DIRT LANE EXISTING IN THAT VICINITY.

SIGNED THIS ____ DAY OF _____, 20____

501187
UTAH LICENSE NUMBER

THE LEGAL DESCRIPTION FOR THE PARCEL TO BE KNOWN AS EDGEWATER BEACH RESORT PHASE 1 IS AS FOLLOWS: A PART OF THE SOUTH WEST QUARTER OF SECTION 13, TOWNSHIP 6 NORTH, RANGE 1 EAST, SALT LAKE BASE AND MERIDIAN, U.S. SURVEY; BEGINNING AT A POINT ON THE NORTHERLY RIGHT OF WAY LINE OF STATE HIGHWAY U-39(40.00 FEET PERPENDICULARLY DISTANT NORTHERLY FROM THE CENTERLINE OF SAID HIGHWAY), WHICH IS 243.89 FEET NORTH 0°25'49" EAST ALONG THE SECTION LINE FROM THE SOUTHWEST CORNER OF SAID SECTION 13; AND RUNNING THENCE NORTH 0°25'49" EAST 230.61 FEET, THENCE SOUTH 89°34'29" EAST 130.80 FEET, THENCE NORTH 6°42'54" EAST 37.53 FEET, THENCE SOUTH 85°09'54" EAST 59.89 FEET, THENCE SOUTHERLY ALONG THE ARC OF A 376.35 FOOT RADIUS CURVE TO THE RIGHT A DISTANCE OF 26.906 FEET (CENTRAL ANGLE EQUALS 4'05'46" AND LONG CHORD BEARS SOUTH 6°52'59" WEST 26.90 FEET), THENCE SOUTH 8°55'52" WEST 73.42 FEET, THENCE SOUTH WESTERLY ALONG THE ARC OF A 111.00 FOOT RADIUS CURVE TO THE LEFT A DISTANCE OF 14.27 FEET (CENTRAL ANGLE EQUALS 7'22'02" AND LONG CHORD BEARS SOUTH 5'14'51" WEST 14.26 FEET), THENCE SOUTH 1°33'50" WEST 23.97 FEET, THENCE SOUTHEASTERLY ALONG THE ARC OF A 61.49 FOOT RADIUS CURVE TO THE LEFT A DISTANCE OF 27.74 FEET (CENTRAL ANGLE EQUALS 25'50'41" AND LONG CHORD BEARS SOUTH 11°21'25" EAST 27.50 FEET), THENCE SOUTHEASTERLY ALONG THE ARC OF A 116.50 FOOT RADIUS CURVE TO THE LEFT A DISTANCE OF 88.90 FEET (CENTRAL ANGLE EQUALS 43'43'22" AND LONG CHORD BEARS SOUTH 46°08'21" EAST 86.76 FEET), THENCE SOUTHEASTERLY ALONG THE ARC OF A 1001.50 FOOT RADIUS CURVE TO THE LEFT A DISTANCE OF 80.00 FEET (CENTRAL ANGLE EQUALS 4'34'36" AND LONG CHORD BEARS SOUTH 70°17'20" EAST 79.98 FEET), THENCE SOUTH 19°36'10" WEST 81.95 FEET, THENCE SOUTH 70°43'57" EAST 32.24 FEET, THENCE SOUTH 26°26'49" EAST 76.32 FEET TO THE RIGHT OF WAY LINE OF STATE U-39 (40.00 FEET PERPENDICULARLY DISTANT NORTHERLY FROM THE CENTERLINE OF SAID HIGHWAY), THENCE TWO (2) COURSES ALONG SAID NORTHERLY RIGHT OF WAY LINE AS FOLLOWS: NORTHWESTERLY ALONG THE ARC OF A 1869.86 FOOT RADIUS CURVE TO THE RIGHT A DISTANCE OF 69.62 FEET (CENTRAL ANGLE EQUALS 2'08'00" AND LONG CHORD BEARS NORTH 71°47'36" WEST 69.61 FEET) AND THENCE NORTH 70°43'36" WEST 318.64 FEET TO THE POINT OF BEGINNING.
CONTAINS 68,986.9 SQ FT OR 1.584 ACRES.

DEVELOPER
 CELTIC BANK
 340 EAST 400 SOUTH
 SALT LAKE CITY, UT 84111
 801-363-6500

SURVEYOR
 ADVANCED ENVIRONMENTAL ENGINEERING
 1975 NORTH MAIN, SUITE #3
 LAYTON, UT 84041

WEBER COUNTY SURVEYOR

I HEREBY CERTIFY THAT THE WEBER COUNTY SURVEYOR'S OFFICE HAS REVIEWED THIS PLAT FOR MATHEMATICAL CORRECTNESS, SECTION CORNER DATA, AND FOR HARMONY WITH LINES AND MONUMENTS ON RECORD IN COUNTY OFFICES. THE APPROVAL OF THIS PLAT BY THE WEBER COUNTY SURVEYOR DOES NOT RELIEVE THE LICENSED LAND SURVEYOR WHO EXECUTED THIS PLAT FROM THE RESPONSIBILITIES AND/OR LIABILITIES ASSOCIATED THEREWITH.

SIGNED THIS ____ DAY OF _____, 2010.

SIGNATURE

WEBER COUNTY COMMISSION ACCEPTANCE

THIS IS TO CERTIFY THAT THIS SUBDIVISION PLAT, THE DEDICATION OF STREETS AND OTHER PUBLIC WAYS AND FINANCIAL GUARANTEE OF PUBLIC IMPROVEMENTS ASSOCIATED WITH THIS SUBDIVISION THEREON ARE HEREBY APPROVED AND ACCEPTED BY THE COMMISSIONERS OF WEBER COUNTY, UTAH

THIS ____ DAY OF _____, 2010.

TITLE _____

CHAIR, WEBER COUNTY COMMISSION

ATTEST _____

WEBER COUNTY ATTORNEY

I HAVE EXAMINED THE FINANCIAL GUARANTEE AND OTHER DOCUMENTS ASSOCIATED WITH THIS SUBDIVISION PLAT AND IN MY OPINION THEY CONFORM WITH THE COUNTY ORDINANCE APPLICABLE THERETO AND NOW IN FORCE AND EFFECT.

SIGNED THIS ____ DAY OF _____, 2010.

SIGNATURE

WEBER COUNTY ENGINEER

I HEREBY CERTIFY THAT THE REQUIRED THE REQUIRED PUBLIC IMPROVEMENT STANDARDS AND DRAWINGS FOR THIS SUBDIVISION CONFORM WITH COUNTY STANDARDS AND THE AMOUNT OF THE FINANCIAL GUARANTEE IS SUFFICIENT FOR THE INSTALLATION OF THESE IMPROVEMENTS.

SIGNED THIS ____ DAY OF _____, 2010.

SIGNATURE

WEBER COUNTY RECORDER

ENTRY NO. _____ FEE PAID _____
 RECORDED _____ FILED FOR RECORD AND
 IN BOOK _____ OF OFFICIAL
 RECORDS, PAGE _____ RECORDED FOR _____

WEBER COUNTY RECORDER
 BY: _____ DEPUTY

EDGEWATER BEACH RESORT PHASE 1
A CONDOMINIUM PLAT
A PART OF THE SOUTHWEST QUARTER OF SECTION 13,
TOWNSHIP 6 NORTH, RANGE 1 EAST
WEBER COUNTY UTAH

SHEET 2 OF 3
 JANUARY 2010

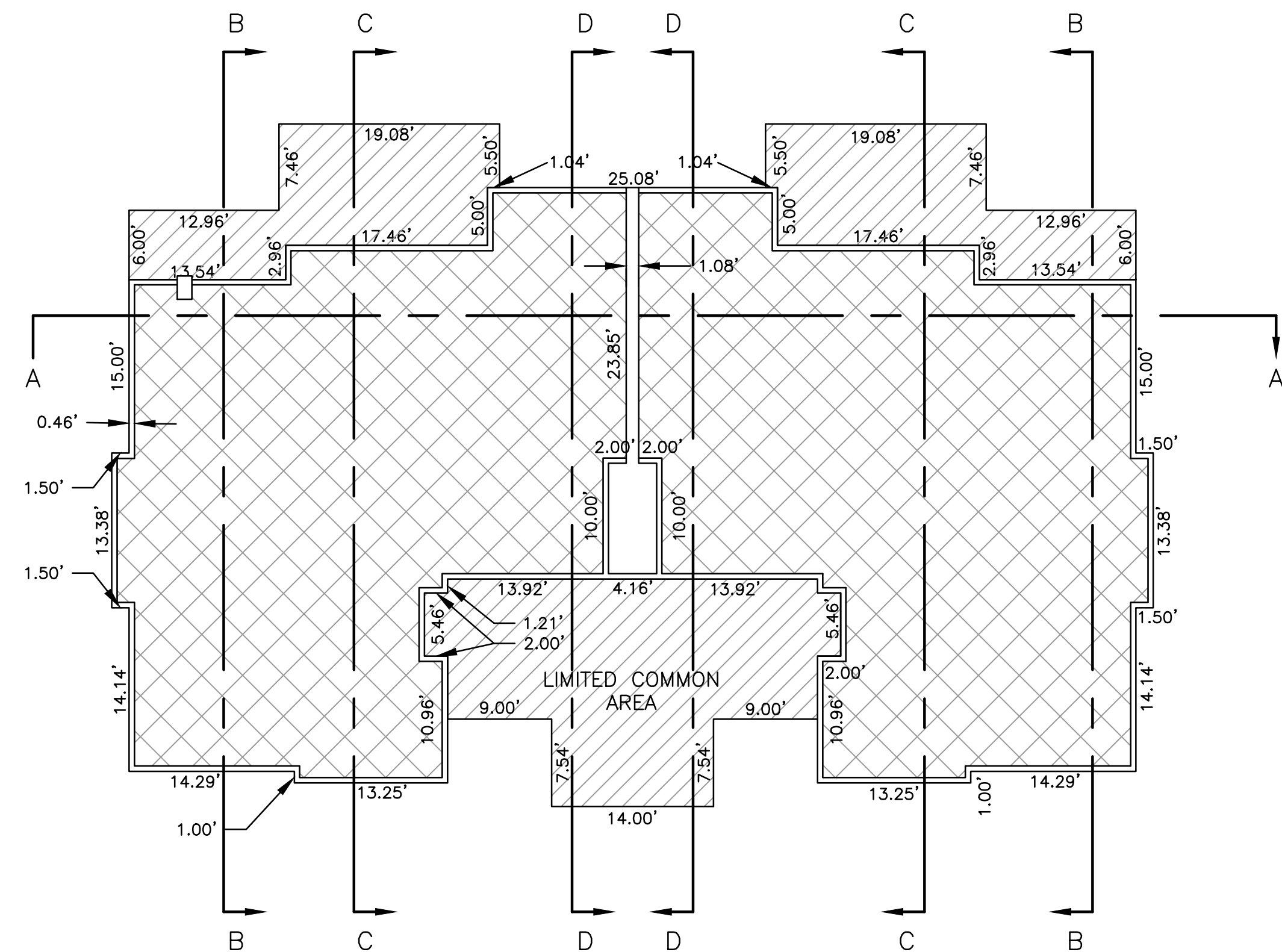

LEVEL 1
 SCALE 1"=10'

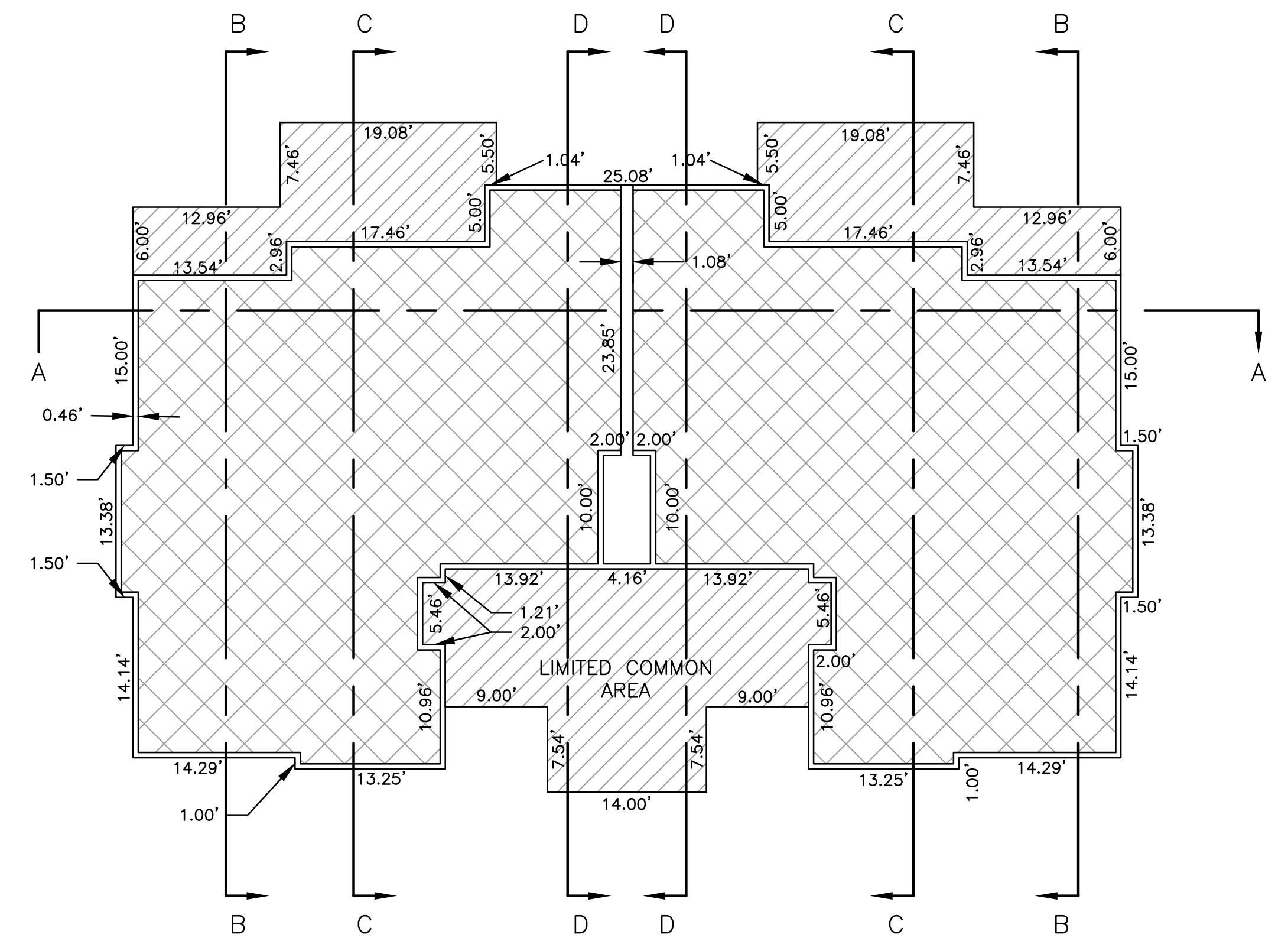

LEVEL 2
 SCALE 1"=10'

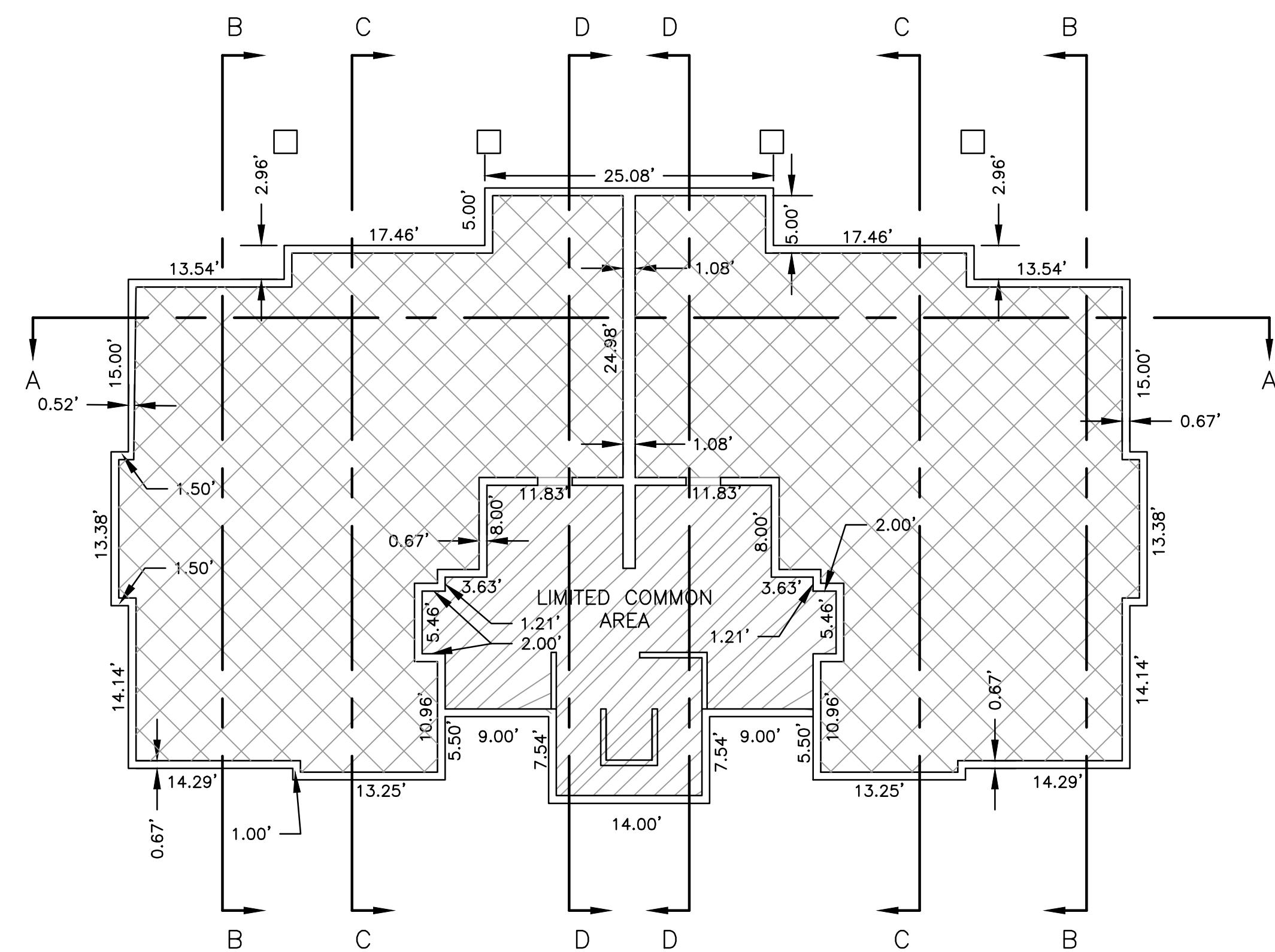

BASEMENT
 SCALE 1"=10'

NOTE:

- EACH CONDOMINIUM UNIT CONTAINED WITHIN THE PROJECT IS AS SHOWN AND IS DESIGNATED BY A NUMBER.
- ALL DRIVEWAYS, PATIOS, DECKS, BALCONIES, ON EACH UNIT CONTAINED WITHIN THE PROJECT ARE CONSIDERED LIMITED COMMON AREAS. THEY ARE SET ASIDE AND RESERVED FOR THE USE OF THE RESPECTIVE CONDOMINIUM UNIT TO WHICH THEY ARE ATTACHED OR APPURTENANT.
- ALL OTHER AREAS CONTAINED WITHIN THE PROJECT, BUT NOT SHOWN WITH DIAGONAL STRIPE OR CROSS HATCHED LINES ARE CONSIDERED COMMON AREA, INCLUDING COVERED AND UNCOVERED PARKING, PRIVATE STREETS, STORM WATER DETENTION AND DRAINAGE EASEMENT AREA.
- DIMENSIONS ON THIS SHEET ARE TO EXTERIOR FOUNDATION ONLY.
- ALL COMMON AREA IS CONSIDERED TO BE AN EASEMENT FOR PUBLIC UTILITY AND DRAINAGE PURPOSES, INCLUDING THE PRIVATE STREETS.

COMMON AREAS AND FACILITIES -

PRIVATE OWNERSHIP -

LIMITED COMMON AREAS AND FACILITIES -

WEBER COUNTY RECORDER	
ENTRY NO. _____	FEE PAID _____
RECORDED _____	FILED FOR RECORD AND _____
IN BOOK _____	OF OFFICIAL _____
RECORDS, PAGE _____	RECORDED FOR _____
WEBER COUNTY RECORDER	
BY: _____	DEPUTY

EDGEWATER BEACH RESORT PHASE 1
A CONDOMINIUM PLAT
A PART OF THE SOUTHWEST QUARTER OF SECTION 13,
TOWNSHIP 6 NORTH, RANGE 1 EAST
WEBER COUNTY UTAH

SHEET 3 OF 3
 JANUARY 2010

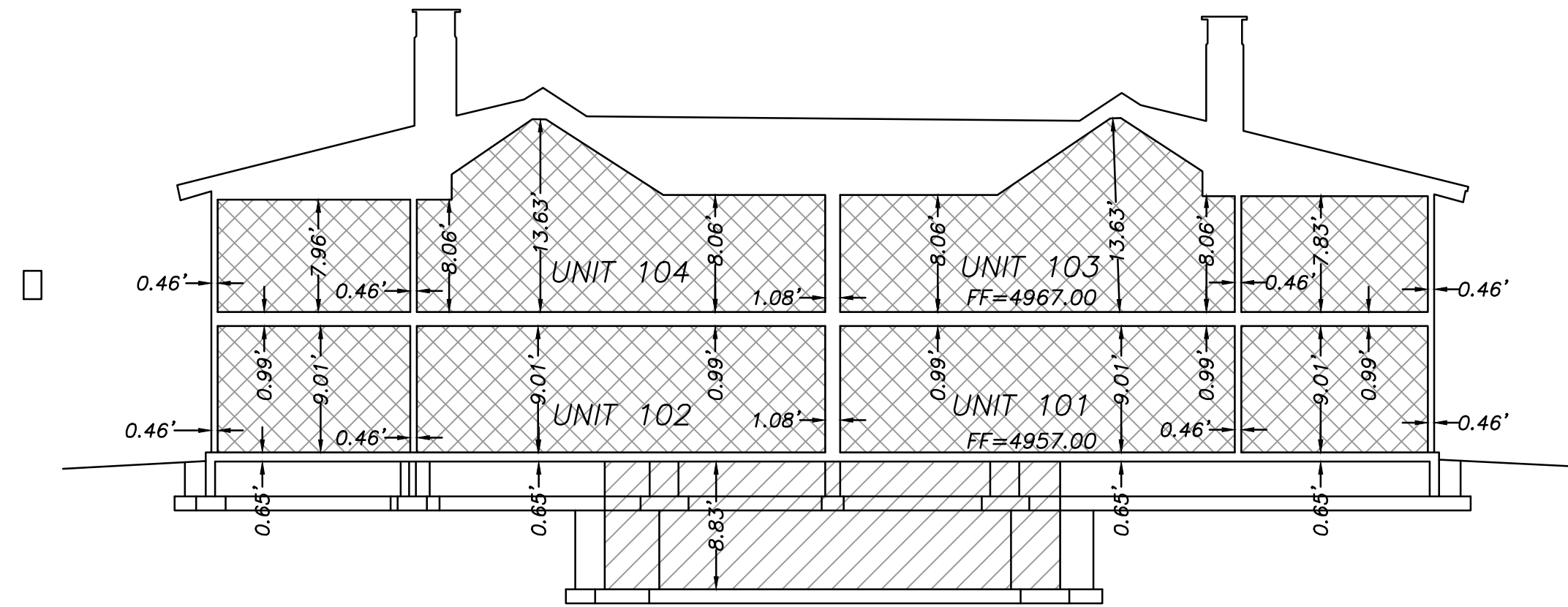

SECTION A-A
 SCALE: 1"=10'

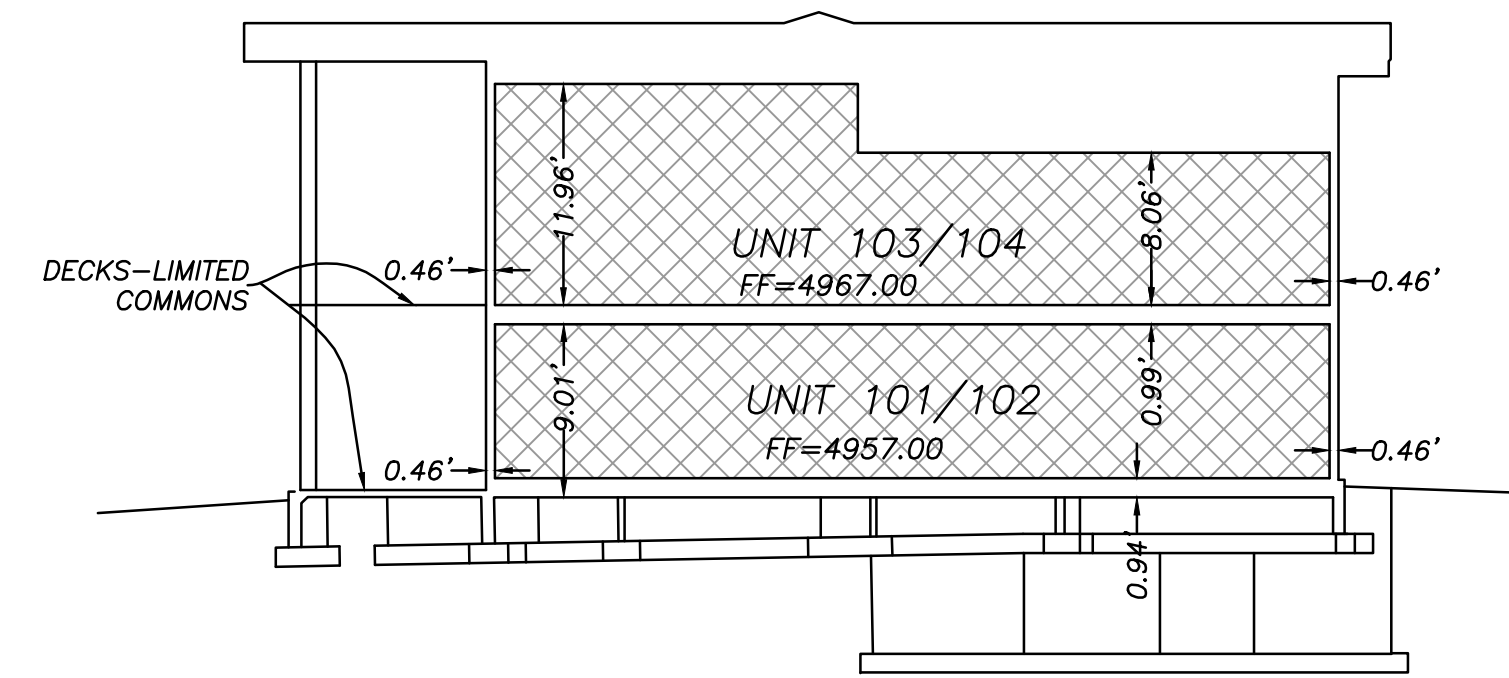

SECTION B-B
 SCALE: 1"=10'

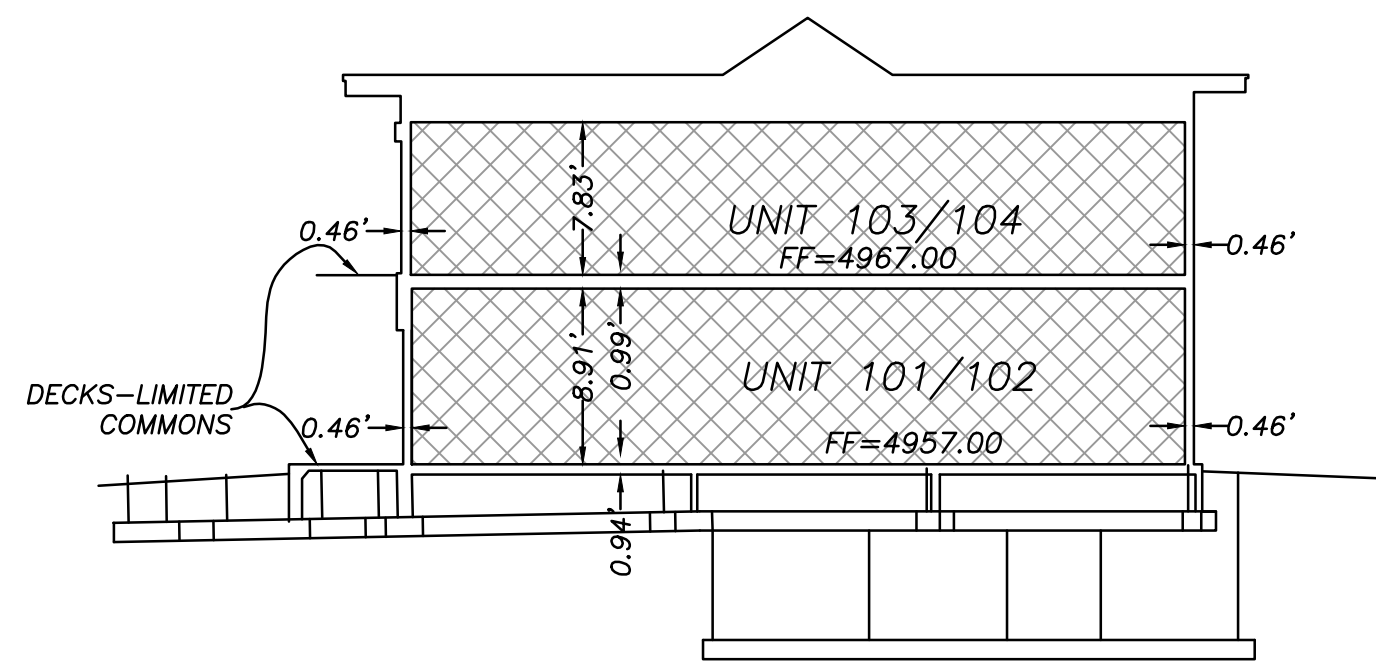

SECTION C-C
 SCALE: 1"=10'

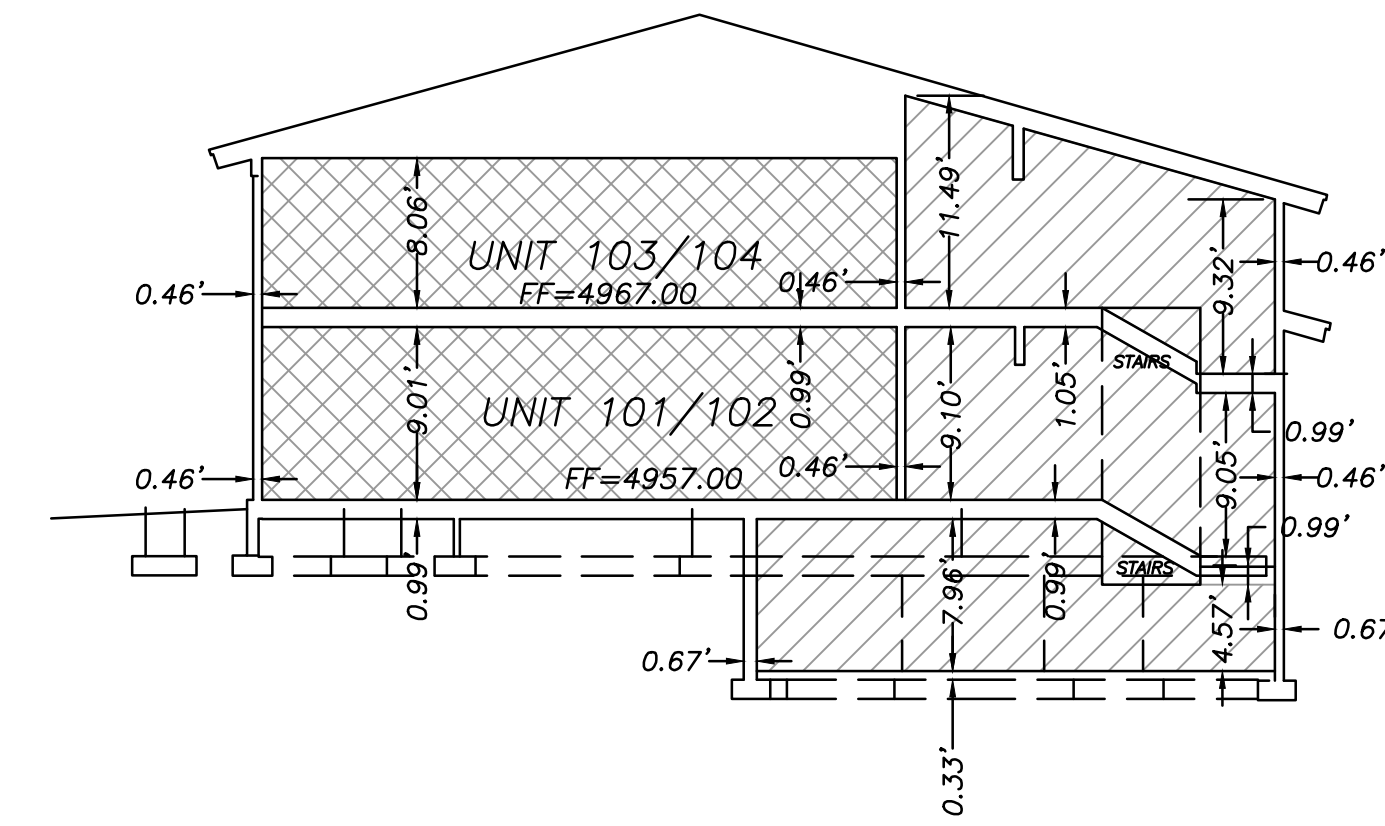

SECTION D-D
 SCALE: 1"=10'

NOTE:

- EACH CONDOMINIUM UNIT CONTAINED WITHIN THE PROJECT IS AS SHOWN AND IS DESIGNATED BY A NUMBER.
- ALL DRIVEWAYS, PATIOS, DECKS, BALCONIES, ON EACH UNIT CONTAINED WITHIN THE PROJECT ARE CONSIDERED LIMITED COMMON AREAS. THEY ARE SET ASIDE AND RESERVED FOR THE USE OF THE RESPECTIVE CONDOMINIUM UNIT TO WHICH THEY ARE ATTACHED OR APPURTENANT.
- ALL OTHER AREAS CONTAINED WITHIN THE PROJECT, BUT NOT SHOWN WITH DIAGONAL STRIPE OR CROSS HATCHED LINES ARE CONSIDERED COMMON AREA, INCLUDING COVERED AND UNCOVERED PARKING, PRIVATE STREETS, STORM WATER DETENTION AND DRAINAGE EASEMENT AREA.
- DIMENSIONS ON THIS SHEET ARE TO EXTERIOR FOUNDATION ONLY.
- ALL COMMON AREA IS CONSIDERED TO BE AN EASEMENT FOR PUBLIC UTILITY AND DRAINAGE PURPOSES, INCLUDING THE PRIVATE STREETS.

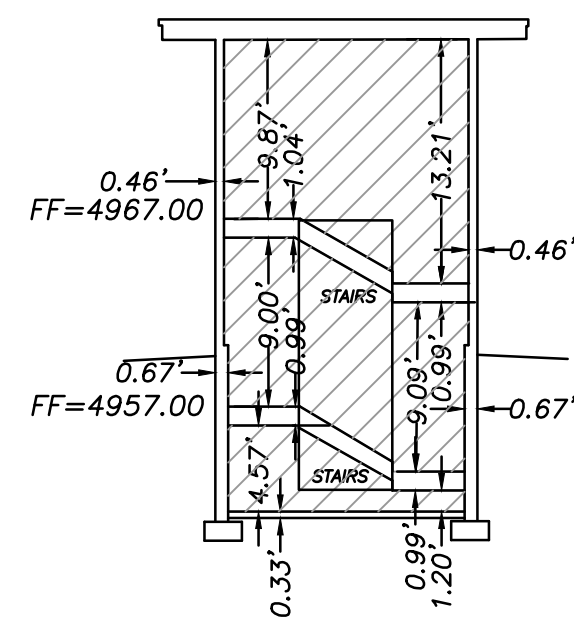

SECTION D-D (DETAIL)
 SCALE: 1"=10'

WEBER COUNTY RECORDER	
ENTRY NO. _____	FEE PAID _____
RECORDED _____	FILED FOR RECORD AND _____
IN BOOK _____	AT _____
RECORDS, PAGE _____	OF OFFICIAL _____
FOR _____	RECORDED _____
WEBER COUNTY RECORDER	
BY: _____	DEPUTY _____