

SUMMIT EDEN RIDGE NESTS-PRUD AMENDMENT 2 AMENDING LOT 5

LOCATED IN THE SOUTH 1/2 OF SECTIONS 5 & 6, TOWNSHIP 7 NORTH, RANGE 2 EAST, SALT LAKE BASE AND MERIDIAN
MAY 2016

BK/PG: 78/89 was the latest AMD

SURVEYOR'S CERTIFICATE

I, RICHARD W. MILLER, DO HEREBY CERTIFY THAT I AM A REGISTERED PROFESSIONAL LAND SURVEYOR IN THE STATE OF UTAH IN ACCORDANCE WITH TITLE 98, CHAPTER 22, PROFESSIONAL ENGINEERS AND LAND SURVEYORS ACT; AND THAT I HAVE COMPLETED A SURVEY OF THE PROPERTY DESCRIBED ON THIS PLAT IN ACCORDANCE WITH UTAH CODE SECTION 17-23-17 AND HAVE VERIFIED ALL MEASUREMENTS AND HAVE PLACED MONUMENTS AS REPRESENTED IN THIS PLAT, AND THAT THIS PLAT SUMMIT EDEN RIDGE NESTS-PRUD AMENDMENT 2, IN WEBER COUNTY, UTAH, HAS BEEN DRAWN CORRECTLY TO THE DESIGNATED SCALE AND IS A TRUE AND CORRECT REPRESENTATION OF THE HEREON DESCRIBED LANDS INCLUDING SAID SUBDIVISION, BASED UPON DATA COMPILED FROM RECORDS IN THE WEBER COUNTY RECORDER'S OFFICE AND FROM SAID SURVEY MADE BY ME ON THE GROUND. I FURTHER CERTIFY THAT THE REQUIREMENTS OF ALL APPLICABLE STATUTES AND ORDINANCES OF WEBER COUNTY CONCERNING ZONING REQUIREMENTS REGARDING LOT MEASUREMENTS HAVE BEEN COMPLIED WITH.



RICHARD W. MILLER
PROFESSIONAL LAND SURVEYOR
UTAH CERTIFICATE NO. 155641

BK/PG: 78/89 was the latest AMD

LEGAL DESCRIPTION

LOT 5 OF SUMMIT EDEN RIDGE NESTS PRUD (AS RECORDED AS ENTRY 2672949), AS PREVIOUSLY AMENDED, IS BEING AMENDED AND IS NOW DESCRIBED AS:

BEGINNING AT A POINT THAT IS WEST 272.96 FEET AND SOUTH 1,441.56 FEET FROM THE EAST QUARTER CORNER OF SECTION 6, TOWNSHIP 7 NORTH, RANGE 2 EAST, SALT LAKE BASE AND MERIDIAN (BASIS OF BEARINGS BEING NORTH 89°55'51" WEST ALONG THE LINE BETWEEN THE NORTHEAST CORNER OF SECTION 1, TOWNSHIP 7 NORTH, RANGE 1 EAST, SALT LAKE BASE AND MERIDIAN AND THE SET WEBER COUNTY MONUMENT ON THE INTERSECTION OF THE WEBER/CACHE COUNTY LINE AND THE SECTION LINE); RUNNING THENCE SOUTH 42°29'59" EAST 37.42 FEET, THENCE SOUTH 10°28'18" WEST 96.87 FEET, THENCE ALONG A 50.79 FOOT LONG CURVE HAVING A CHORD OF NORTH 85°37'38" WEST 50.79 FEET WITH A RADIUS OF 2,990.76 FEET, THENCE NORTH ~~85°10'43" WEST 50.81 FEET~~, THENCE NORTH 00°04'00" WEST ~~64.16~~ FEET, THENCE NORTH 18°26'17" WEST 2.45 FEET, THENCE NORTH 40°00'19" EAST 68.15 FEET TO THE POINT OF BEGINNING.

DESCRIPTION DOES NOT CLOSE

SURVEY NARRATIVE:

- THIS SURVEY WAS PERFORMED TO AMEND LOT 5 OF SUMMIT EDEN RIDGE NEST PRUD AS RECORDED IN THE OFFICE OF THE WEBER COUNTY RECORDERS OFFICE (ENTRY NUMBER 2672949, BOOK 75, PAGES 43 - 44). THE CHANGES INCLUDE A MINOR SHIFT AND ROTATION OF LOT 5 INCLUDING ADJUSTMENTS TO ITS APPURTENANT LIMITED COMMON AREA.
- THE BASIS OF BEARINGS FOR THIS PLAT IS NORTH 89°55'51" WEST BETWEEN THE NORTHEAST CORNER OF SECTION 1, TOWNSHIP 7 NORTH, RANGE 1 EAST, SALT LAKE BASE AND MERIDIAN AND A FOUND WEBER COUNTY LINE MONUMENT SET BY THE WEBER COUNTY SURVEYOR'S OFFICE. THIS BEARING DIFFERS FROM WEBER COUNTY SURVEYORS BEARING BY 00°00'14" AS SHOWN ON COUNTY LINE DECLARATION RECORDED PLAT BOOK 74, PAGE 64.

PLAT NOTES:

THIS PLAT AMENDMENT IS SUBJECT TO ALL LEGALLY ENFORCEABLE RESTRICTIONS, RIGHTS AND LIMITATIONS SET FORTH IN THE PLAT NOTES THAT APPEAR ON THE SUMMIT EDEN RIDGE NESTS PRUD (ENTRY# 2672949), AS AMENDED, UNLESS OTHERWISE NOTED ON THIS PLAT.

OWNER'S DEDICATION:

WE, THE UNDERSIGNED OWNERS OF THE HEREIN DESCRIBED TRACT OF LAND, DO HEREBY SET APART AND SUBDIVIDE THE SAME INTO LOTS AS SHOWN HEREON, SUBJECT TO ALL OF THE RESTRICTIONS, RIGHTS AND LIMITATIONS SET FORTH IN THE PLAT NOTES, AND NAME SAID TRACT, TO BE KNOWN AS:

SUMMIT EDEN RIDGE NESTS PRUD AMENDMENT 2

AND DO HEREBY GRANT AND DEDICATE THOSE CERTAIN EASEMENTS DESCRIBED IN PLAT NOTE 9. SUCH NOTES AND THE RESERVATION AND GRANT OF EASEMENTS DESCRIBED THEREIN ARE INCORPORATED HEREIN BY REFERENCE.

IN WITNESS WHEREOF, DECLARANT HAS EXECUTED THIS OWNER'S DEDICATION AS OF THE ____ DAY OF _____, 20____.

SMHG PHASE 1 LLC, A DELAWARE LIMITED LIABILITY COMPANY
BY: SMHG INVESTMENTS LLC, A DELAWARE LIMITED LIABILITY COMPANY, IT'S SOLE MEMBER

BY: _____
NAME: JEFF WERBELOW
TITLE: AUTHORIZED SIGNATORY

ACKNOWLEDGEMENTS:

STATE OF UTAH } S.S.
COUNTY OF WEBER

THE FOREGOING INSTRUMENT WAS ACKNOWLEDGED BEFORE ME THIS ____ DAY OF _____, 20____ BY JEFF WERBELOW, AUTHORIZED SIGNATORY OF SMHG INVESTMENTS LLC, THE SOLE MEMBER OF SMHG PHASE 1 LLC.

NOTARY PUBLIC

MY COMMISSION EXPIRES: _____

RESIDING IN: _____

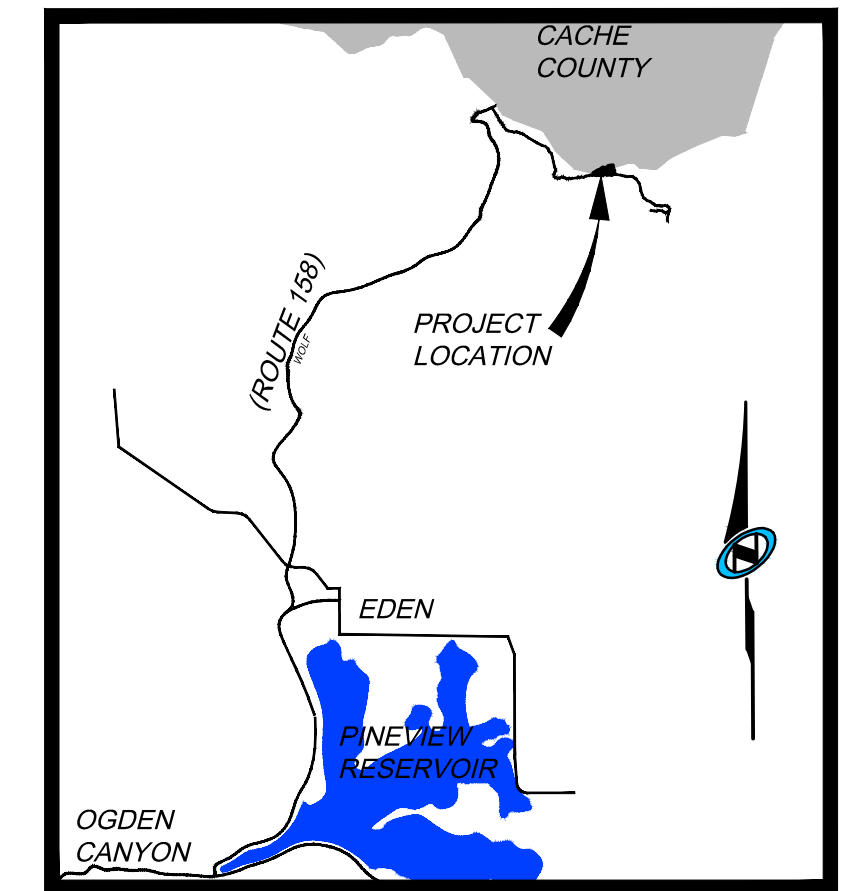

Vicinity Map

N.T.5

SMHG PHASE 1, LLC.
3632 N. WOLF CREEK DR.
EDEN, UT, 84310

WEBER COUNTY ATTORNEY
I HAVE EXAMINED THE FINANCIAL GUARANTEE AND OTHER DOCUMENTS ASSOCIATED WITH THIS SUBDIVISION PLAT AND IN MY OPINION THEY CONFORM WITH THE COUNTY ORDINANCE APPLICABLE THERETO AND NOW IN FORCE AND AFFECT.
SIGNED THIS _____ DAY OF _____, 20____.

SIGNATURE

WEBER COUNTY SURVEYOR
I HEREBY CERTIFY THAT THE WEBER COUNTY SURVEYOR'S OFFICE HAS REVIEWED THIS PLAT FOR MATHEMATICAL CORRECTNESS, SECTION CORNER DATA AND FOR HARMONY WITH LINES AND MONUMENTS ON RECORD IN THE COUNTY OFFICES. THE APPROVAL OF THIS PLAT BY THE WEBER COUNTY SURVEYORS DOES NOT RELIEVE THE LICENSED LAND SURVEYOR WHO EXECUTED THIS PLAT FROM RESPONSIBILITIES AND/OR LIABILITIES ASSOCIATED THEREWITH. SIGNED THIS _____ DAY OF _____, 20____.

COUNTY SURVEYOR

WEBER COUNTY ENGINEER
I HEREBY CERTIFY THAT THE REQUIRED PUBLIC IMPROVEMENT STANDARDS AND DRAWINGS FOR THIS SUBDIVISION CONFORM WITH COUNTY STANDARDS AND THE AMOUNT OF THE FINANCIAL GUARANTEE IS SUFFICIENT FOR THE INSTALLATION OF THESE IMPROVEMENTS.
SIGNED THIS _____ DAY OF _____, 20____.

SIGNATURE

WEBER COUNTY PLANNING COMMISSION APPROVAL
THIS IS TO CERTIFY THAT THIS SUBDIVISION PLAT WAS DULY APPROVED BY THE WEBER COUNTY PLANNING COMMISSION ON THE DAY OF _____, 20____.
CHAIRMAN-WEBER COUNTY PLANNING COMMISSION

ASSEST

TITLE

WEBER COUNTY COMMISSION ACCEPTANCE
THIS IS TO CERTIFY THAT THIS SUBDIVISION PLAT, THE DEDICATION OF STREETS AND OTHER PUBLIC WAYS AND FINANCIAL GUARANTEE OF PUBLIC IMPROVEMENTS, IN ACCORDANCE WITH AN INTERLOCAL AGREEMENT BETWEEN WEBER COUNTY AND CACHE COUNTY, ENTRY #263768, RECORDED 28 MAY 2013, ASSOCIATED WITH THIS SUBDIVISION THEREON ARE HEREBY APPROVED AND ACCEPTED BY THE COMMISSIONERS OF WEBER COUNTY, UTAH THIS _____ DAY OF _____, 20____.
CHAIRMAN, WEBER COUNTY COMMISSION

ASSEST

TITLE

CACHE RECORDED #
STATE OF UTAH, COUNTY OF CACHE, RECORDED AND FILED AT THE
REQUEST OF: _____
ENTRY NO: _____
DATE: _____ TIME: _____
BOOK: _____ PAGE: _____
FEE \$ _____
CACHE COUNTY RECORDER

WEBER RECORDED #
STATE OF UTAH, COUNTY OF WEBER, RECORDED AND FILED AT THE
REQUEST OF: _____
ENTRY NO: _____
DATE: _____ TIME: _____
BOOK: _____ PAGE: _____
FEE \$ _____
WEBER COUNTY RECORDER

Sheet 1 of 2
NIV5
NOLTE VERTICAL FIVE
5217 SOUTH STATE STREET, SUITE 300 MURRAY, UT 84107
801.743.1300 TEL 801.743.0300 FAX
WWW.NOLTE.COM

SUMMIT EDEN RIDGE NESTS-PRUD AMENDMENT 2 AMENDING LOT 5

LOCATED IN THE SOUTH 1/2 OF SECTIONS 5 & 6, TOWNSHIP 7 NORTH, RANGE 2 EAST, SALT LAKE BASE AND MERIDIAN
MAY 2016

2014-1-17 NONE
 N:\S\B\0793\CA00\PHASE 1 PLAT AMENDMENTS\RDGE NESTS\AMENDMENT 2\SURVEY\PLATS
 5102 AMENDMENT 2.DWG Layout1

FOUND WEBER COUNTY LINE MONUMENT PER WEBER COUNTY SURVEYOR 2013, GOOD CONDITION
 (N 89°56'05" W 1380.98' RECORD)
 BASIS OF BEARINGS N 89°55'51" W 1381.07'
 STATE PLANE GRID PER WEBER COUNTY SURVEY OFFICE
 NORTHEAST CORNER SECTION 1, TOWNSHIP 7 NORTH, RANGE 1 EAST SALT LAKE BASE AND MERIDIAN FOUND GLO 1944 BRASS CAP, GOOD CONDITION
 S89°30'01"E 4866.98'
 S 0°23'40" W 2678.58'
 WEST 272.96' (TIE)
 NORTHEAST CORNER SECTION 6, TOWNSHIP 7 NORTH, RANGE 2 EAST SALT LAKE BASE AND MERIDIAN FOUND 1944 GLO BRASS CAP, GOOD CONDITION (CLOSING CORNER 17.68' SOUTH)
 EAST QUARTER CORNER SECTION 6, TOWNSHIP 7 NORTH, RANGE 2 EAST SALT LAKE BASE AND MERIDIAN FOUND 1941 GLO BRASS CAP, GOOD CONDITION

LINE TABLE		
LINE	LENGTH	DIRECTION
L1	55.74'	S 18°26'17" E
L2	2.45'	S 18°26'17" E

CURVE TABLE					
CURVE #	LENGTH	RADIUS	DELTA	CHORD LENGTH	CHORD BEARING
C1	100.00'	3023.76'	1°53'41"	100.00	S85° 24' 51"E
C2	123.18'	120.00'	58°48'56"	117.85	S33° 02' 46"W
C4	50.79'	2990.76'	0°58'23"	50.79	N85° 37' 38"W
C5	44.59'	30.00'	85°09'16"	40.60	S51° 03' 40"W
C6	136.58'	145.00'	53°58'12"	131.59	S35° 28' 08"W
C7	48.29'	225.00'	12°17'45"	48.19	S56° 18' 22"W

C14 DATA MISSING

- LEGEND**
- BOUNDARY LINE
 - LOT LINE
 - - - SECTION LINE
 - - - QUARTER SECTION LINE
 - - - COUNTY LINE
 - - - ADJOINER DEED LINES
 - - - AREA TIE LINES
 - ◆ CALCULATED SECTION CORNER AS NOTED
 - ◆ SECTION CORNER AS NOTED
 - ◆ STREET MONUMENT
 - FOUND REBAR WITH PLASTIC CAP STAMPED "NOLTE ASSOC."
 - ▨ PRIVATE LOT
 - ▨ LIMITED COMMON AREA
 - COMMON AREA
 - ⑤ PRUD LOT NUMBER

LOT CONFIGURATION
ALL LOTS HAVE SAME BUILDING LOT DIMENSIONS
N.T.S

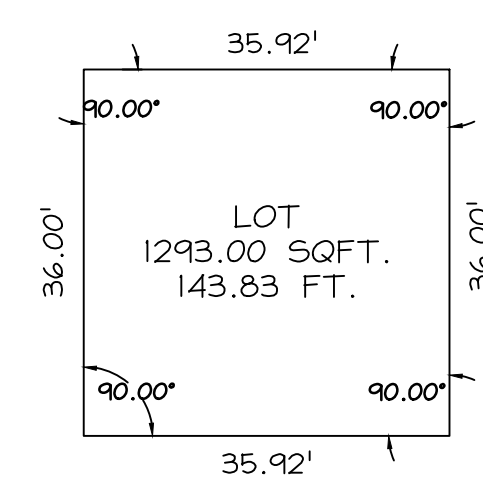

SMHG PHASE I, LLC.
3632 N. WOLFCREEK DR.
EDEN, UT, 84310

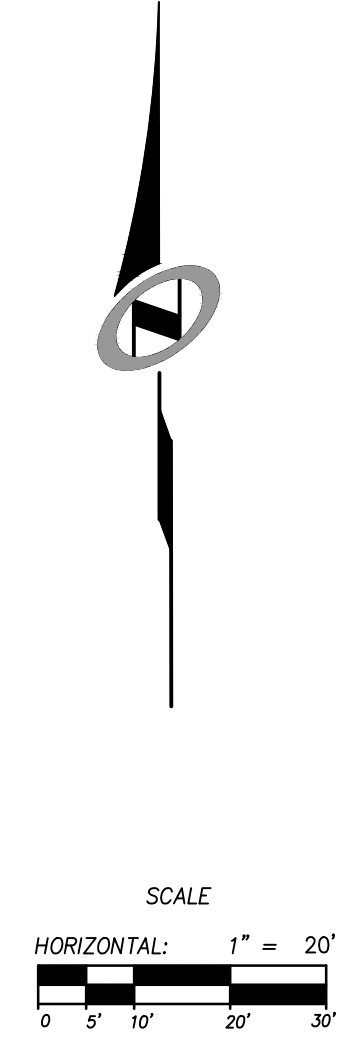
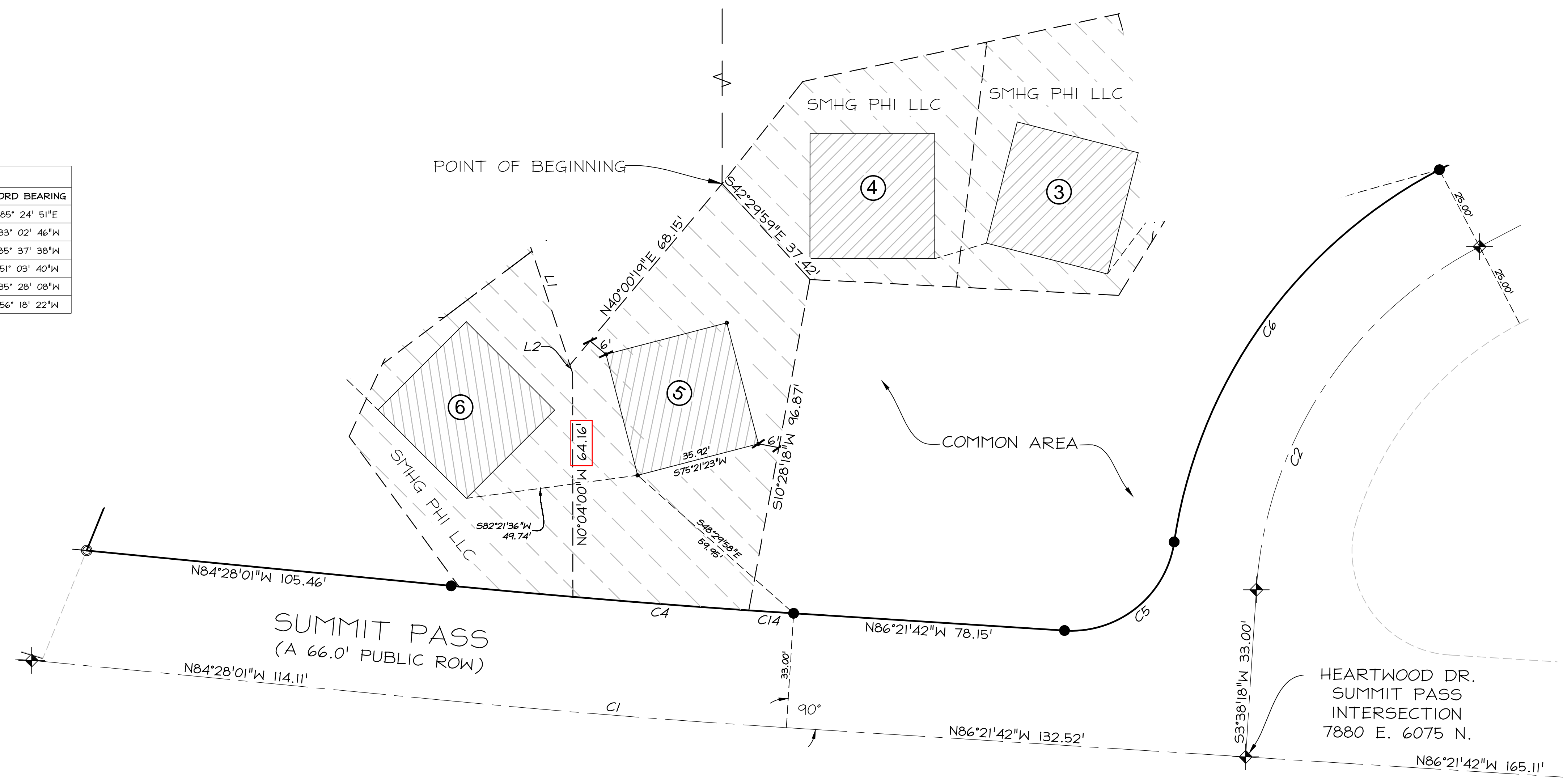

CACHE RECORDED #
STATE OF UTAH, COUNTY OF CACHE, RECORDED AND FILED AT THE
REQUEST OF: _____
ENTRY NO.: _____
DATE: _____ TIME: _____
BOOK: _____ PAGE: _____
FEE \$ _____
CACHE COUNTY RECORDER

WEBER RECORDED #
STATE OF UTAH, COUNTY OF WEBER, RECORDED AND FILED AT THE
REQUEST OF: _____
ENTRY NO.: _____
DATE: _____ TIME: _____
BOOK: _____ PAGE: _____
FEE \$ _____
WEBER COUNTY RECORDER