

Scale ~ 1" = xx'

Legend

- EXISTING FENCE
- - - EASEMENTS
- STREET CENTERLINE
- ◆ FND SECTION CORNER
- ▲ FND STREET MONUMENT
- FND CURB NAIL
- FND REBAR AND CAP
- SET #5x24" REBAR AND CAP STAMPED LANDMARK
- ▨ ROAD/STREET DEDICATION

Vicinity Map

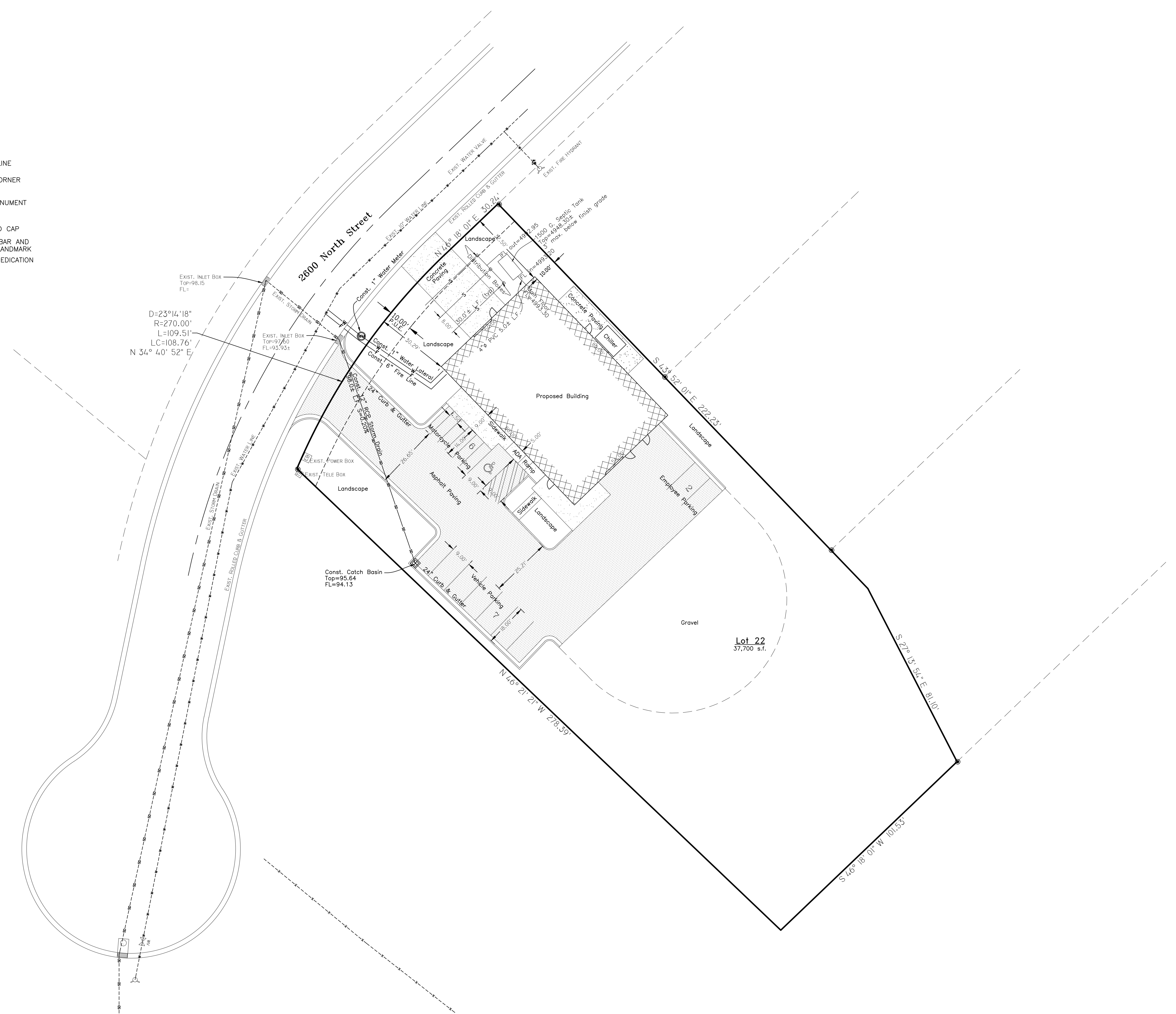

$D=23^{\circ}14'18''$   
 $R=270.00'$   
 $L=109.51'$   
 $LC=108.76'$   
 $N\ 34^{\circ}40'52''\ E$

**Lot 22**  
 37,700 s.f.

<b>Landmark Surveying, Inc.</b> <small>A Complete Land Surveying Service www.LandmarkSurveyingUtah.com</small>		4646 South 3500 West - #A-3 West Haven, UT 84401 801-731-4075
<b>CLIENT: Peterson Builders</b>		
Parcel ID No xx 1/4 of Section xx, Township x North, Range x West, Salt Lake Base and Meridian.	DRAWN BY: TDK CHECKED BY: TDK	
Revisions:	DATE: 8/20/2015 FILE: 3549	SHEET <b>1 of 3</b>
<b>Site, Utility Plan</b>		



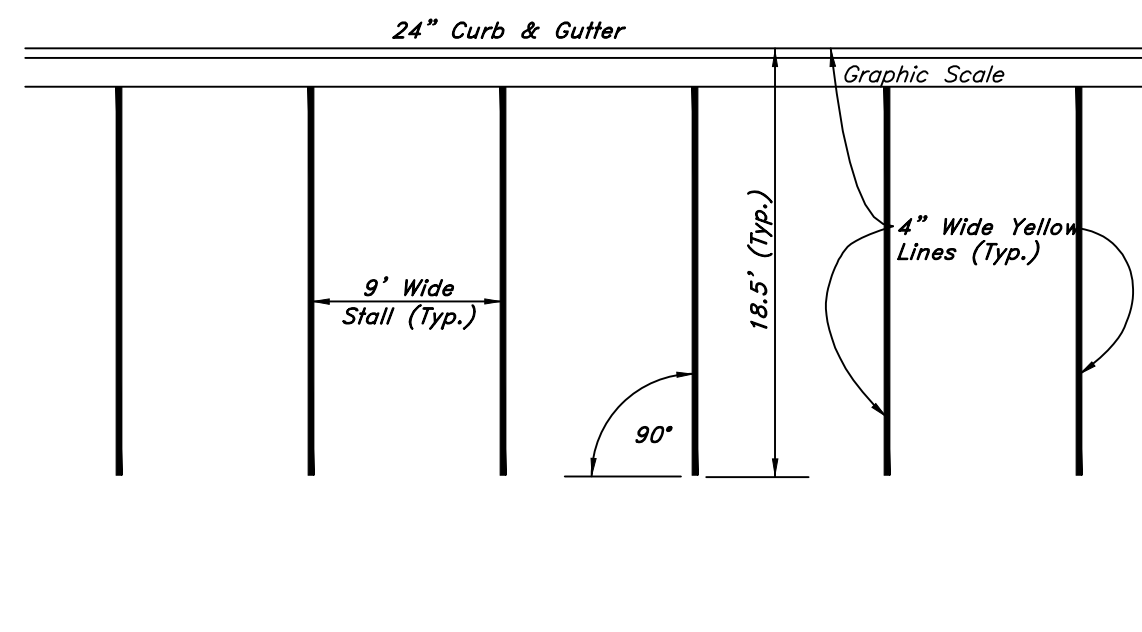

1 Typical Parking Lot Striping Plan  
Not to Scale

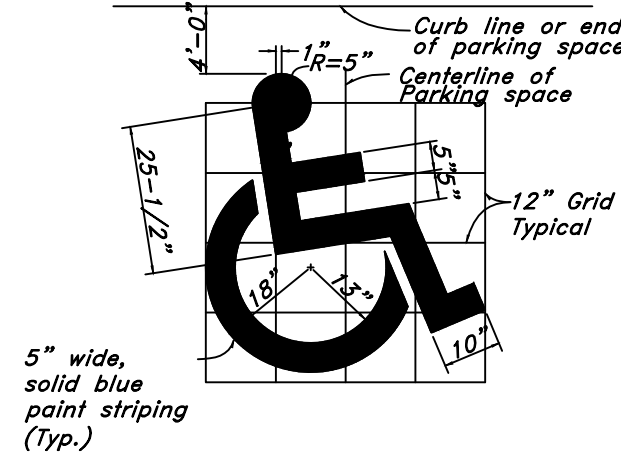

2 Handicap Symbol  
Not to Scale

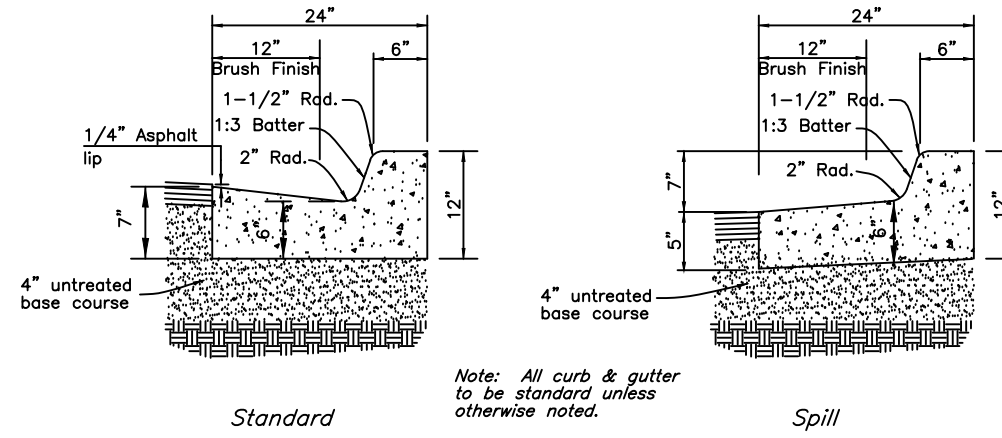

3 Typical Section - 24" Curb & Gutter  
Not to Scale

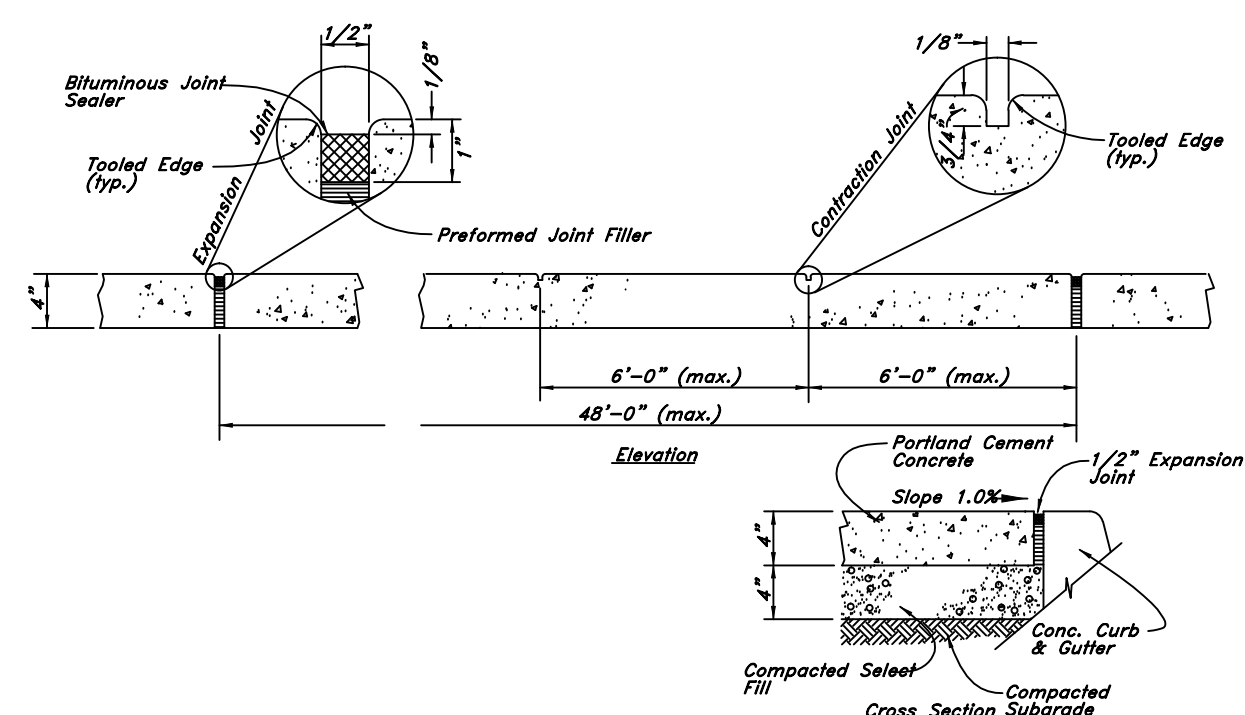

4 Concrete Sidewalk  
Not to Scale

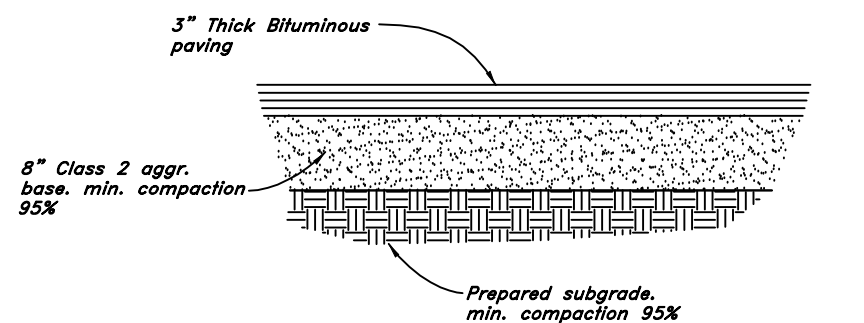

5 Typical Bituminous Pavement Section  
Not to Scale

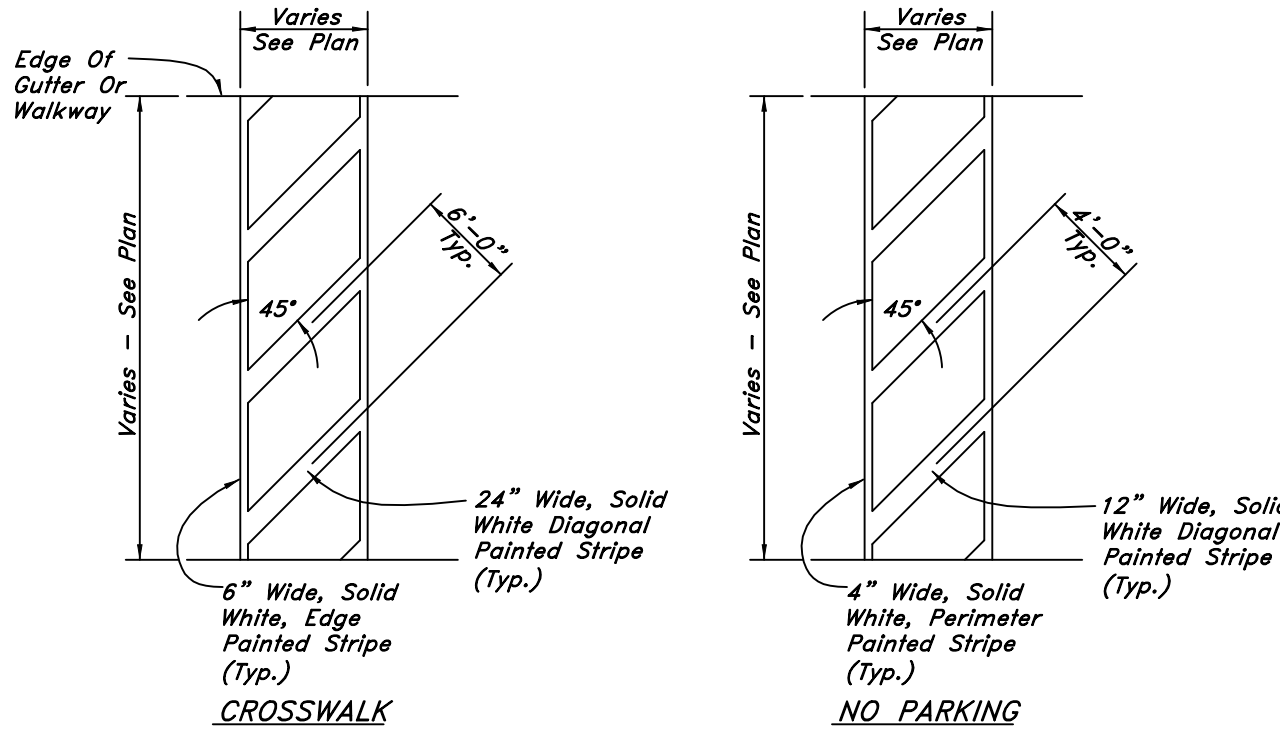

6 Striping  
Not to Scale

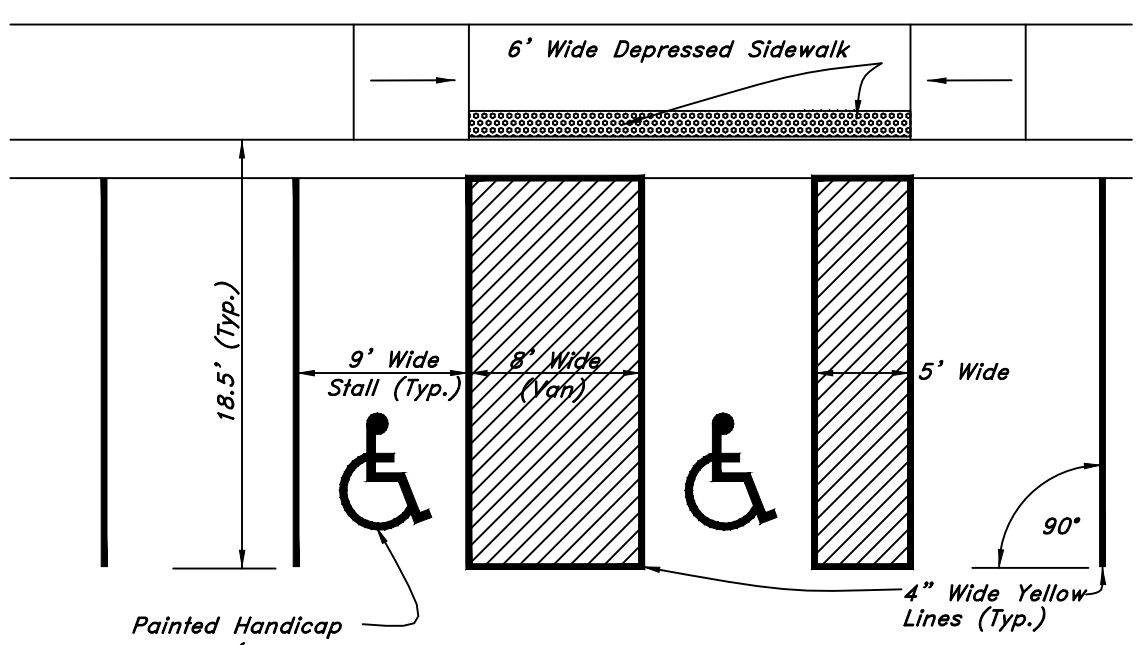

7 Typical ADA Parking Striping Plan  
Not to Scale

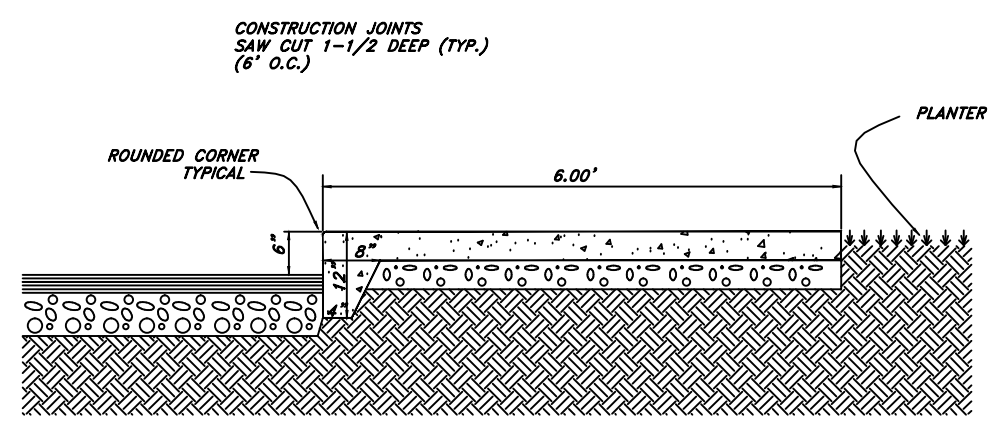

8 Thickened Edge Walk  
Not to Scale

# Not to Scale

# Not to Scale

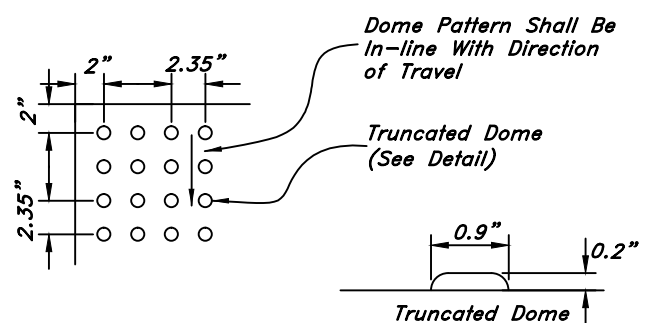

All Sidewalk Curb Ramps Shall Have Detectable Warning Surfaces That Extend The Full Width Of Curb Ramp and 2' Deep. Ramp shall be different color, 20% minimum different shade, than rest of sidewalk. Use Cast Iron for Truncated Domes.

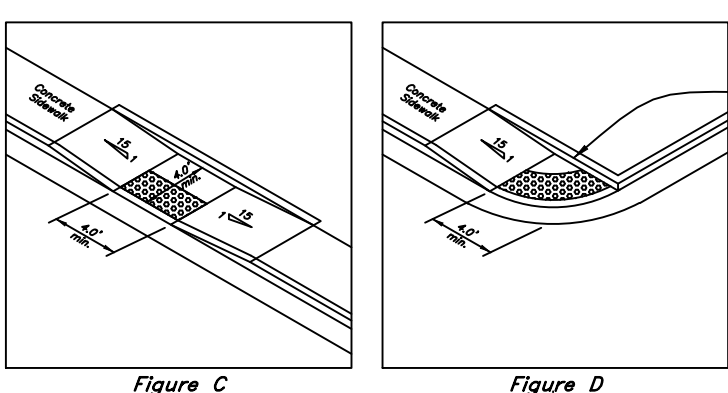
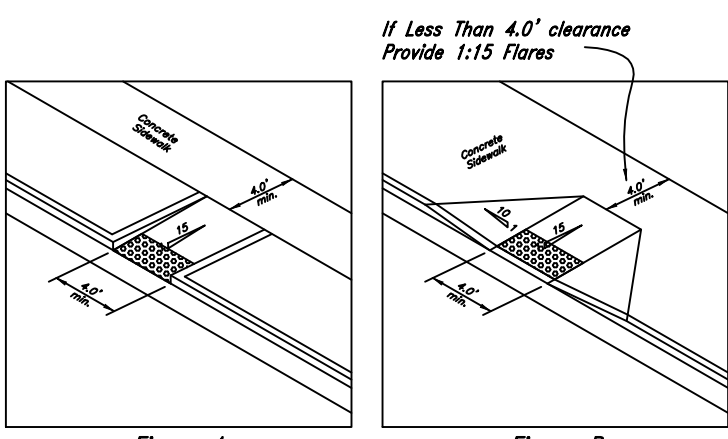

9 Typical ADA Ramp Detail  
Not to Scale

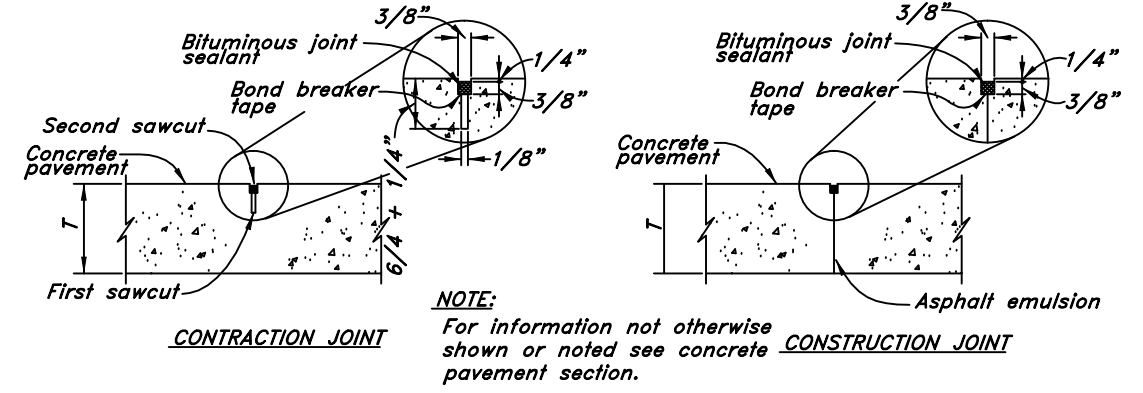
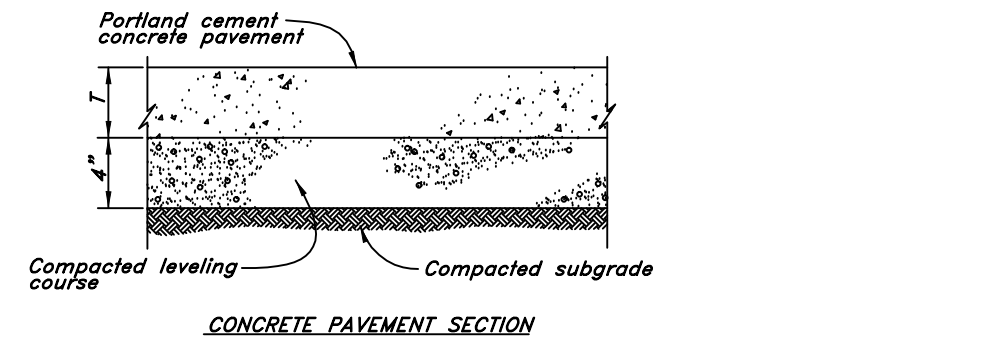
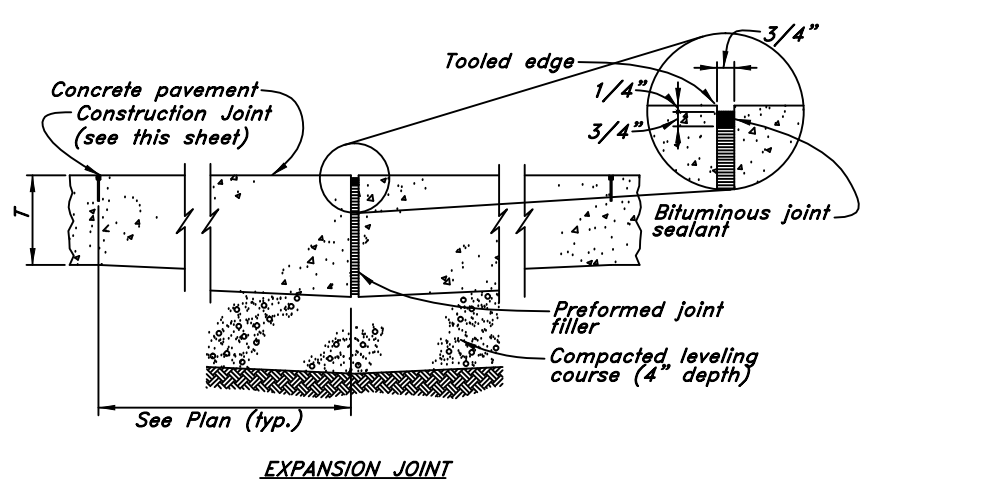

10 Portland Cement Concrete Pavement  
Not to Scale

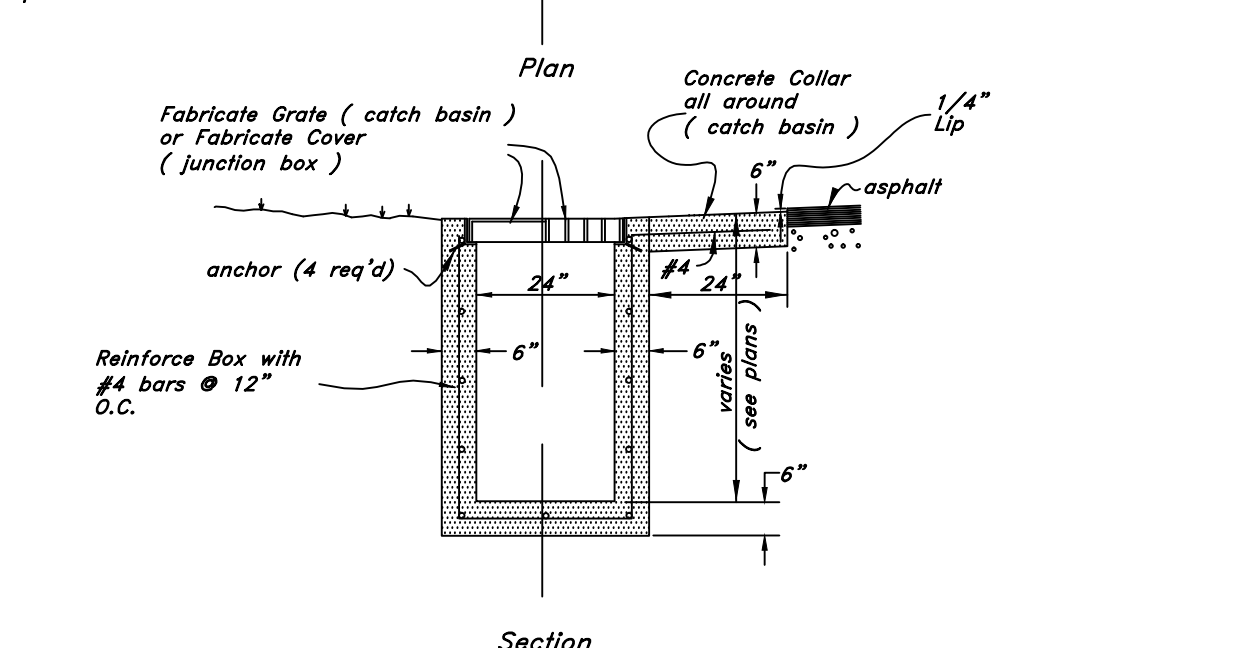
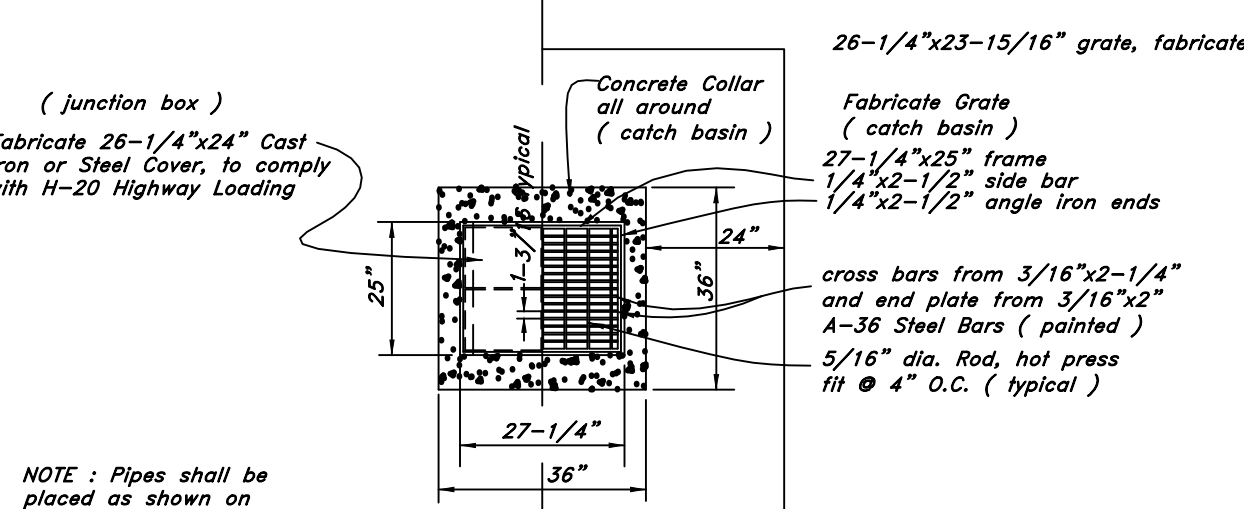

11 Catch Basin/Junction Box  
Not to Scale

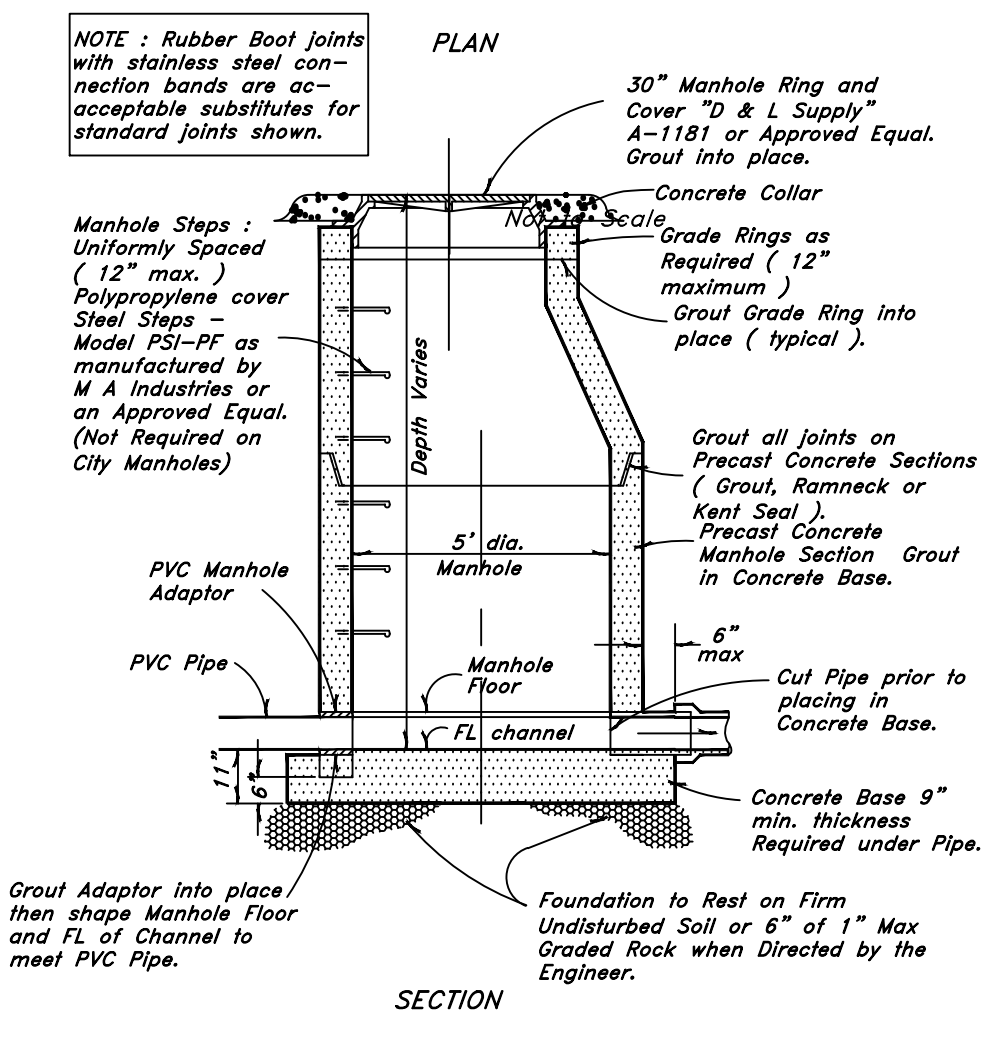
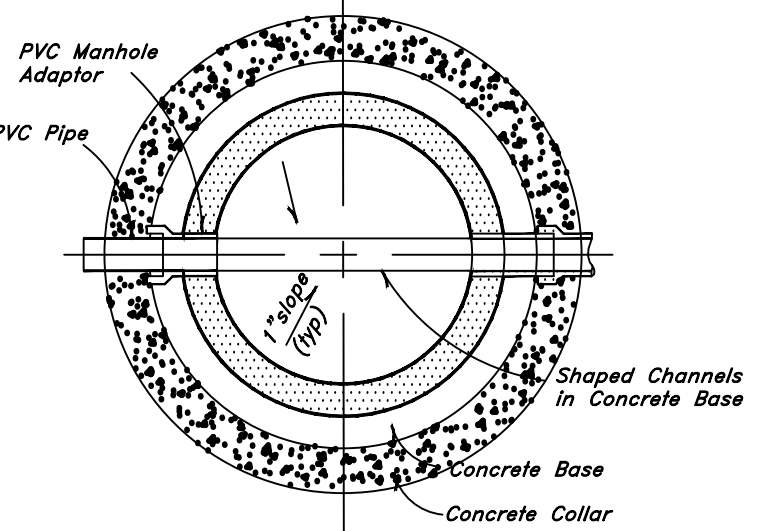

12 Typical Manhole Detail  
Not to Scale

# Not to Scale

Landmark Surveying, Inc.  
A Complete Land Surveying Service  
www.LandmarkSurveyingUtah.com  
4646 South 3500 West - #A-3  
West Haven, UT 84401  
801-731-4075

CLIENT: Peterson Builders

Parcel ID No xx 1/4 of Section xx, Township x North, Range x West, Salt Lake Base and Meridian.	DRAWN BY: TDK
Revisions:	CHECKED BY: TDK
	DATE: 8/20/2015
	FILE: 3549

This Plan is the Intellectual Property of Landmark Surveying, Inc. - all legal rights are reserved.