

Scale ~ 1" = xx'

Legend

- EXISTING FENCE
- - - EASEMENTS
- STREET CENTERLINE
- ◆ FND SECTION CORNER
- ▲ FND STREET MONUMENT
- FND CURB NAIL
- FND REBAR AND CAP
- SET #5x24" REBAR AND CAP STAMPED LANDMARK
- ▨ ROAD/STREET DEDICATION

Vicinity Map

D=23°14'18"
R=270.00'
L=109.51'
LC=108.76'
N 34° 40' 52" E

LEGEND:

- CENTERLINE
- EXISTING DITCH
- PROPOSED SWALE (DITCH)
- PROPOSED FENCE LINE
- EXISTING FENCE
- EXISTING WATER LINE
- PROPOSED WATER LINE
- EXISTING SANITARY SEWER
- PROPOSED SANITARY SEWER
- EXISTING STORM DRAIN
- PROPOSED STORM DRAIN
- EXISTING IRRIGATION LINE
- EXISTING POWER LINE
- PROPOSED INLET
- PROPOSED SIGN
- ⊙ EXISTING SEWER MANHOLE
- ⊙ EXISTING FIRE HYDRANT
- ⊙ EXISTING VALVE
- ⊙ EXISTING TELEPHONE BOX
- ⊙ EXISTING POWER MANHOLE
- ⊙ EXISTING UTILITY POLE
- XXX EXISTING GROUND ELEVATION
- XXX-○ PROPOSED GROUND ELEVATION
- EDA EDGE OF ASPHALT
- TA TOP OF ASPHALT
- TC TOP OF CURB
- FL FLOW LINE
- TBS TOP BACK OF SIDEWALK
- ▨ ASPHALT SURFACE
- ▨ CONCRETE SURFACE

GENERAL NOTES

1. EXISTING IMPROVEMENTS ARE SHOWN AS ACCURATELY AS POSSIBLE ACCORDING TO AVAILABLE INFORMATION. IT SHALL BE THE SOLE RESPONSIBILITY OF THE CONTRACTOR TO FIELD VERIFY THE LOCATION AND ELEVATION OF ALL UTILITIES, SHOWN OR NOT SHOWN ON THE PLANS.
2. ALL CONSTRUCTION SHALL BE IN ACCORDANCE WITH WEBER COUNTY STANDARDS AND SPECIFICATIONS. ANY DEVIATION FROM THOSE STANDARDS SHALL BE APPROVED IN ADVANCE OF CONSTRUCTION BY A REPRESENTATIVE OF WEBER COUNTY.

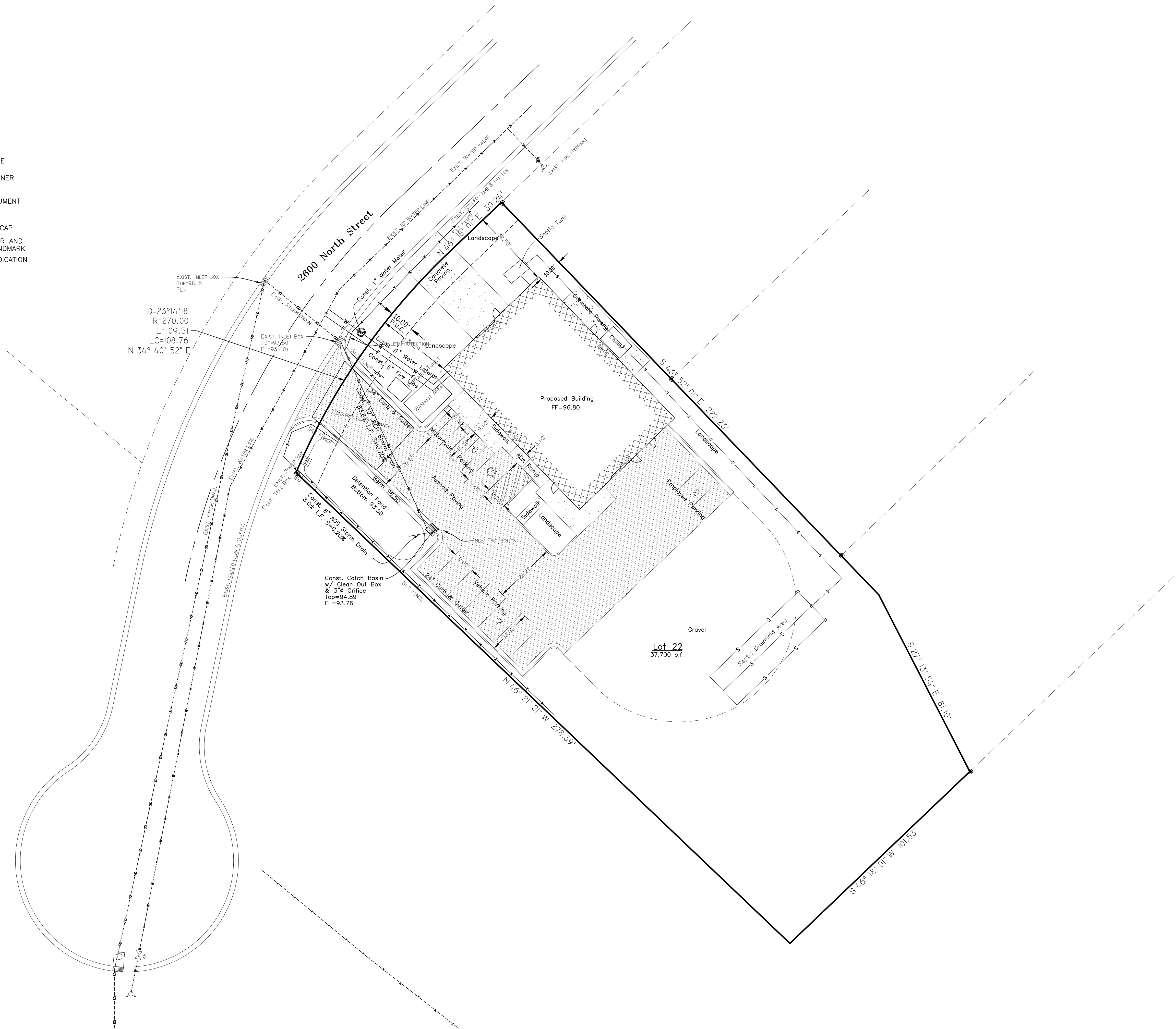

File Name

Landmark Surveying, Inc.
A Complete Land Surveying Service
www.LandmarkSurveyingUtah.com

4646 South 3500 West - #A-3
West Haven, UT 84401
801-731-4075

CLIENT: Peterson Builders

Parcel ID No 22-159-0007 NW 1/4 of Section 34, Township 7 North, Range 1 East, Salt Lake Base and Meridian.	DRAWN BY: TDK CHECKED BY: TDK
Revisions:	DATE: 12/16/2015 FILE: 3549

SHEET
1 of 3

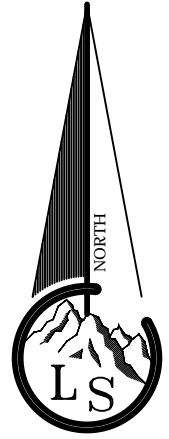

Scale ~ 1" = xx'

Legend

- EXISTING FENCE
- - - EASEMENTS
- STREET CENTERLINE
- ◆ FND SECTION CORNER
- ▲ FND STREET MONUMENT
- FND CURB NAIL
- FND REBAR AND CAP

LEGEND:

- CENTERLINE
- - - EXISTING DITCH
- - - PROPOSED SWALE (DITCH)
- - - PROPOSED FENCE LINE
- - - EXISTING FENCE
- - - EXISTING WATER LINE
- - - PROPOSED WATER LINE
- - - EXISTING SANITARY SEWER
- - - PROPOSED SANITARY SEWER
- - - EXISTING STORM DRAIN
- - - PROPOSED STORM DRAIN
- - - EXISTING IRRIGATION LINE
- - - EXISTING POWER LINE
- EXISTING INLET
- PROPOSED INLET
- ▲ PROPOSED SIGN
- EXISTING SEWER MANHOLE
- EXISTING FIRE HYDRANT
- EXISTING VALVE
- EXISTING TELEPHONE BOX
- EXISTING POWER MANHOLE
- EXISTING UTILITY POLE
- XXX EXISTING GROUND ELEVATION
- XXX- PROPOSED GROUND ELEVATION
- EDA EDGE OF ASPHALT
- TA TOP OF ASPHALT
- TC TOP OF CURB
- FL FLOW LINE
- TBS TOP BACK OF SIDEWALK
- ASPHALT SURFACE
- CONCRETE SURFACE

GENERAL NOTES

1. EXISTING IMPROVEMENTS ARE SHOWN AS ACCURATELY AS POSSIBLE ACCORDING TO AVAILABLE INFORMATION. IT SHALL BE THE SOLE RESPONSIBILITY OF THE CONTRACTOR TO FIELD VERIFY THE LOCATION AND ELEVATION OF ALL UTILITIES, SHOWN OR NOT SHOWN ON THE PLANS.
2. ALL CONSTRUCTION SHALL BE IN ACCORDANCE WITH WEBER COUNTY STANDARDS AND SPECIFICATIONS. ANY DEVIATION FROM THOSE STANDARDS SHALL BE APPROVED IN ADVANCE OF CONSTRUCTION BY A REPRESENTATIVE OF WEBER COUNTY.



File Name

Landmark Surveying, Inc.
 A Complete Land Surveying Service
 www.LandmarkSurveyingUtah.com

4646 South 3500 West - #A-3
 West Haven, UT 84401
 801-731-4075

CLIENT: Peterson Builders

Parcel ID No 22-159-0007 NW 1/4 of Section 34, Township 7 North, Range 1 East, Salt Lake Base and Meridian.	DRAWN BY: TDK
Revisions:	CHECKED BY: TDK
	DATE: 12/16/2015
	FILE: 3549

SHEET
2 of 3

Grading & Drainage Plan

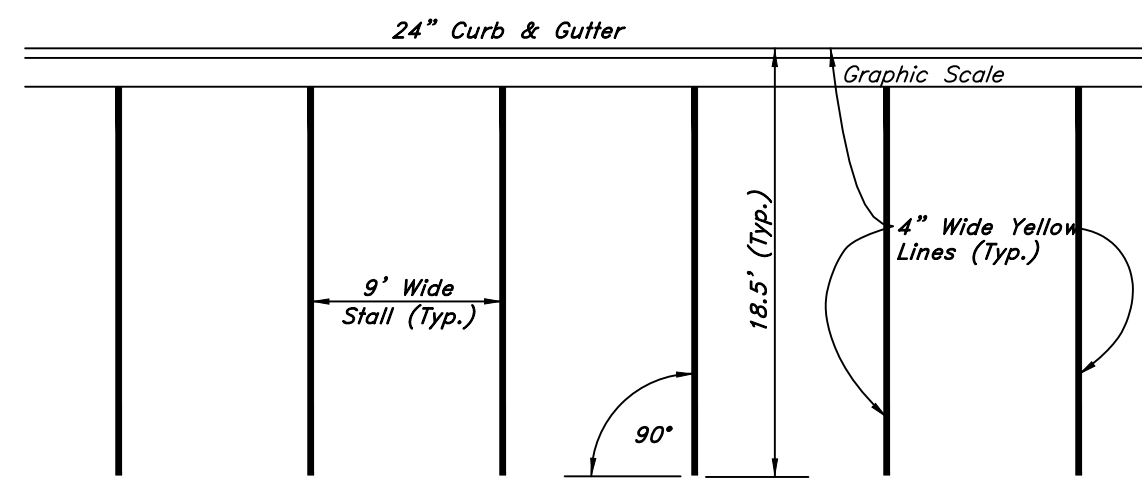

1 Typical Parking Lot Striping Plan

Not to Scale

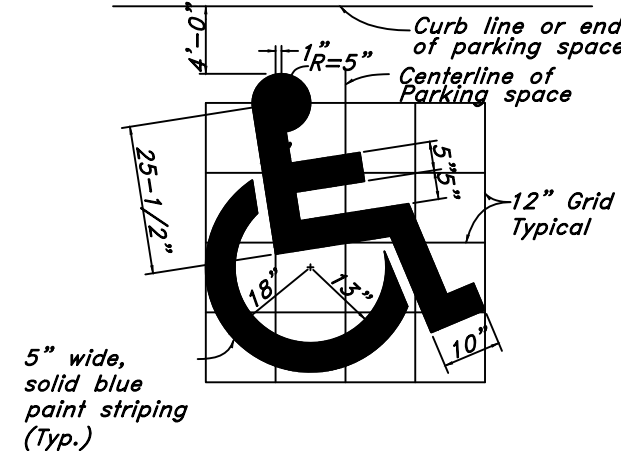

2 Handicap Symbol

Not to Scale

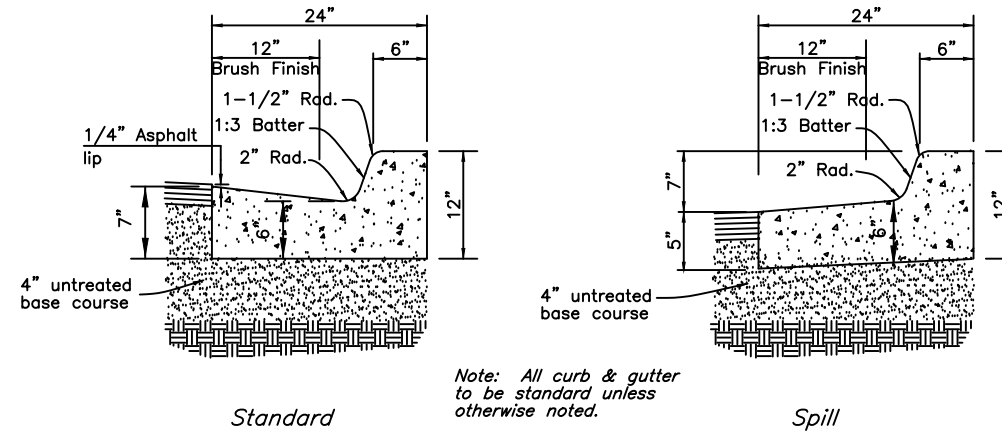

3 Typical Section - 24" Curb & Gutter

Not to Scale

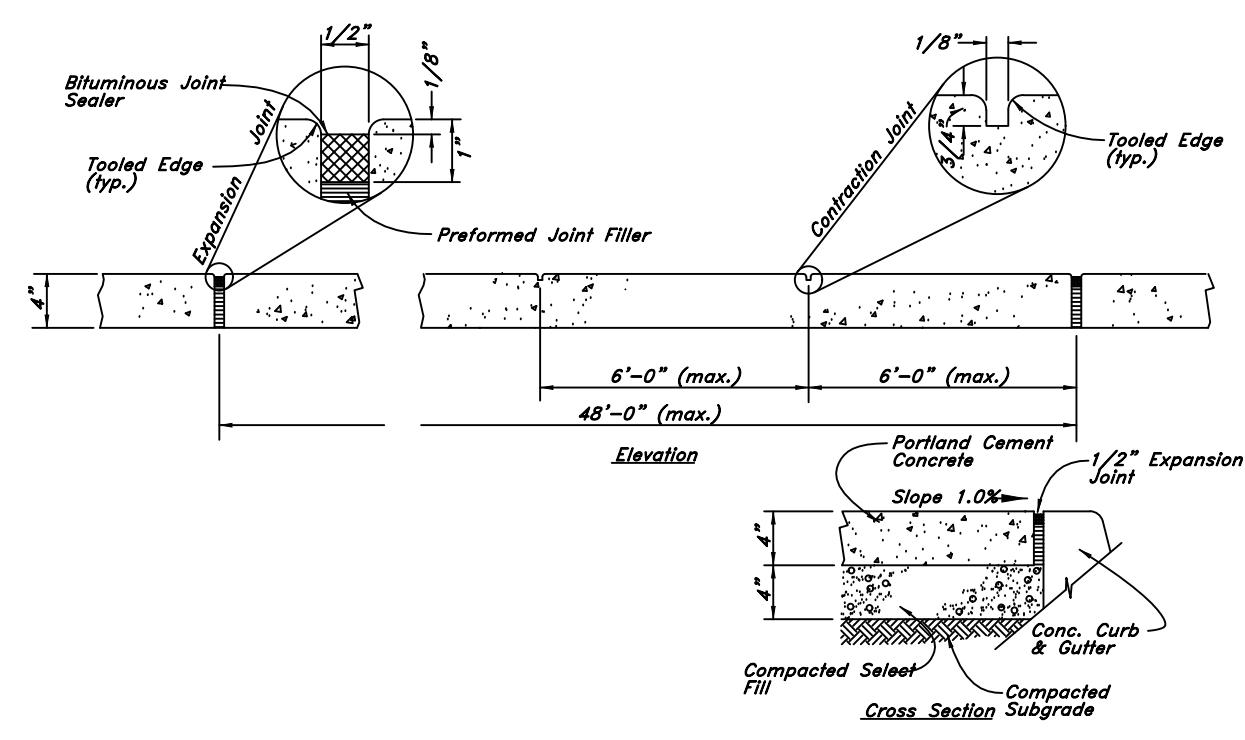

4 Concrete Sidewalk

Not to Scale

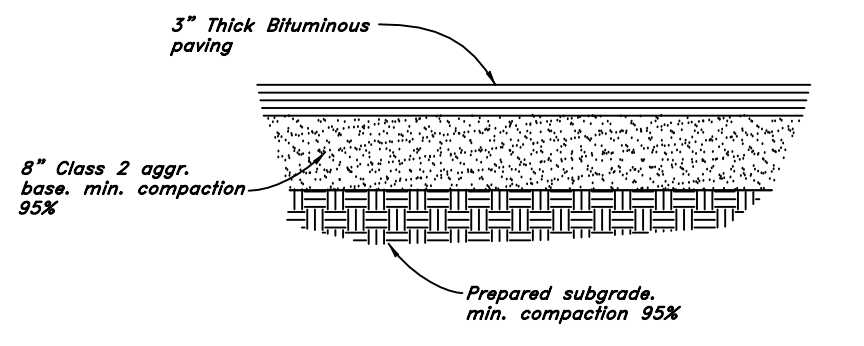

5 Typical Bituminous Pavement Section

Not to Scale

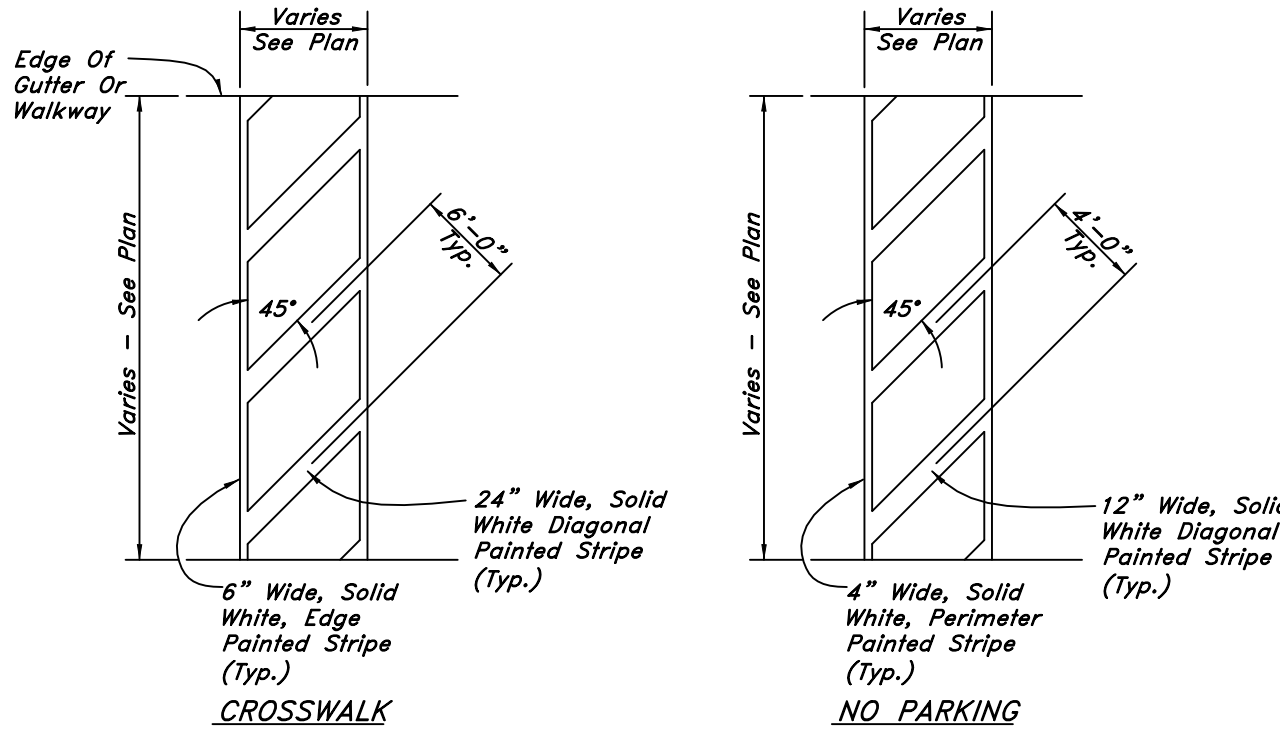

6 Striping

Not to Scale

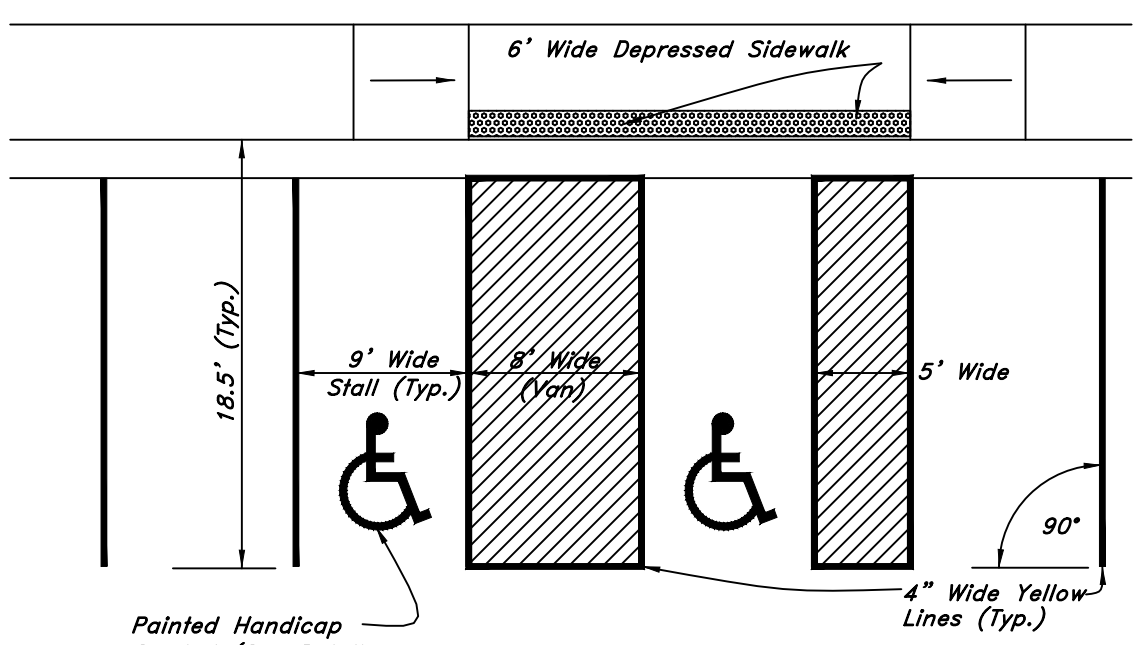

7 Typical ADA Parking Striping Plan

Not to Scale

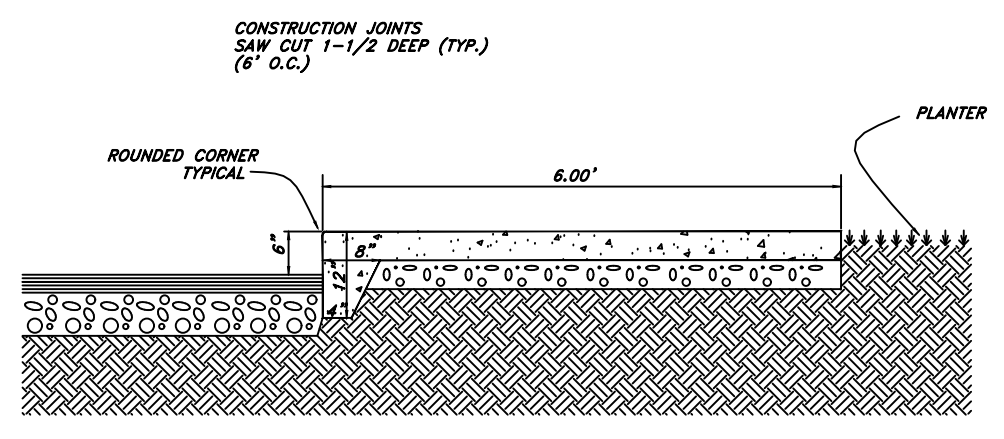

8 Thickened Edge Walk

Not to Scale

#

Not to Scale

#

Not to Scale

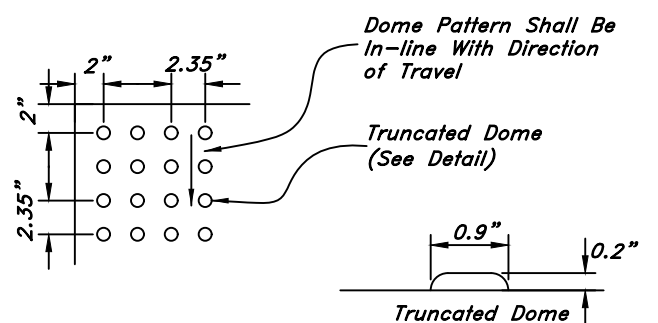

All Sidewalk Curb Ramps Shall Have Detectable Warning Surfaces That Extend The Full Width Of Curb Ramp and 2' Deep. Ramp shall be different color, 20% minimum different shade, than rest of sidewalk. Use Cast Iron for Truncated Domes.

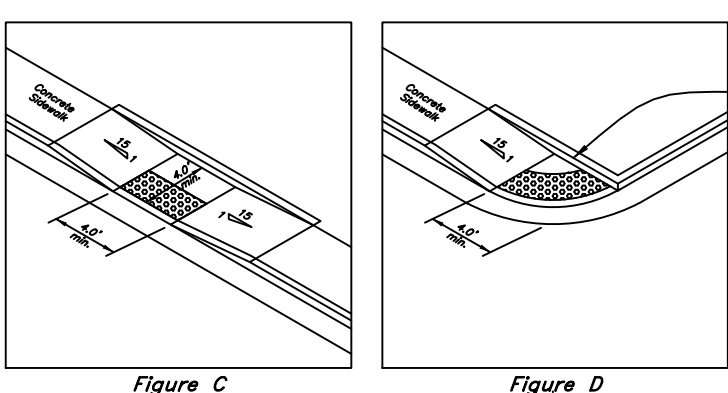
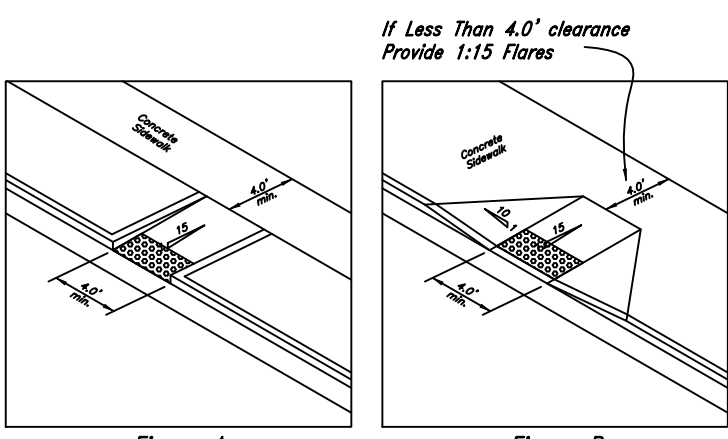

9 Typical ADA Ramp Detail

Not to Scale

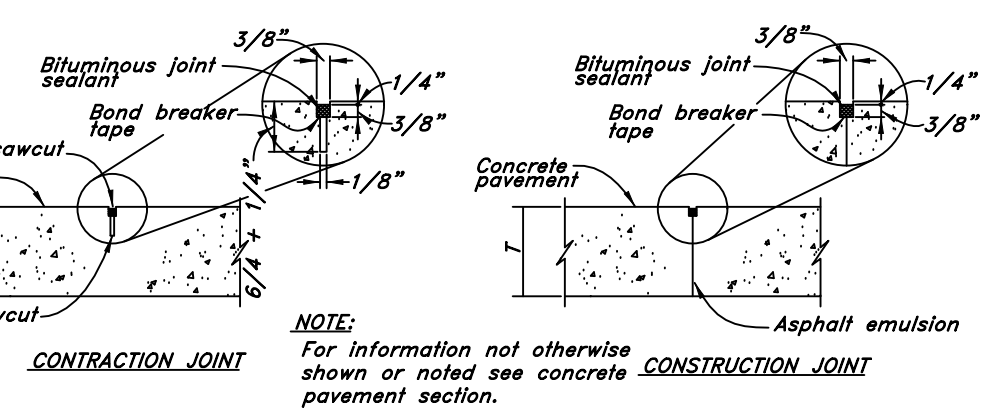
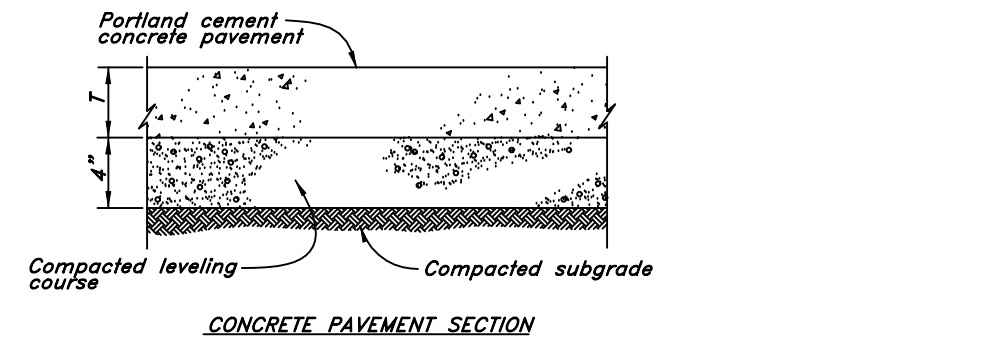
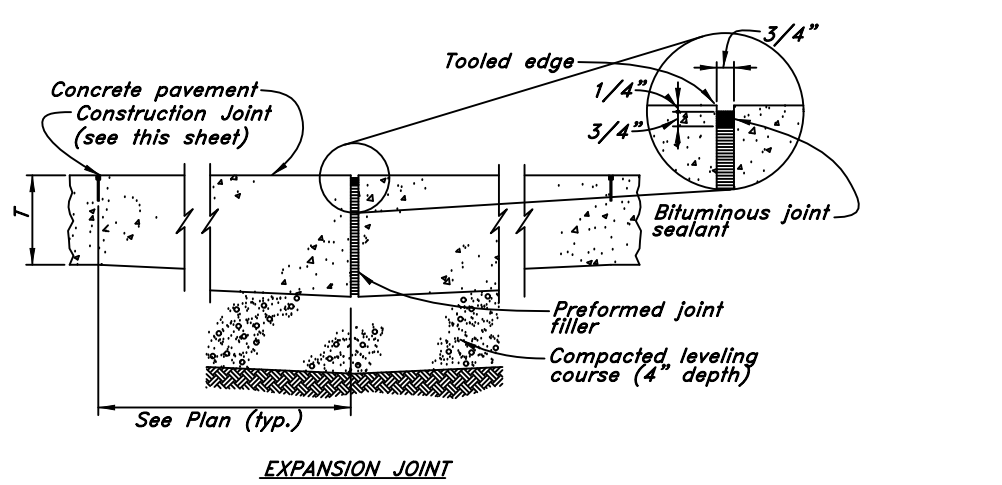

10 Portland Cement Concrete Pavement

Not to Scale

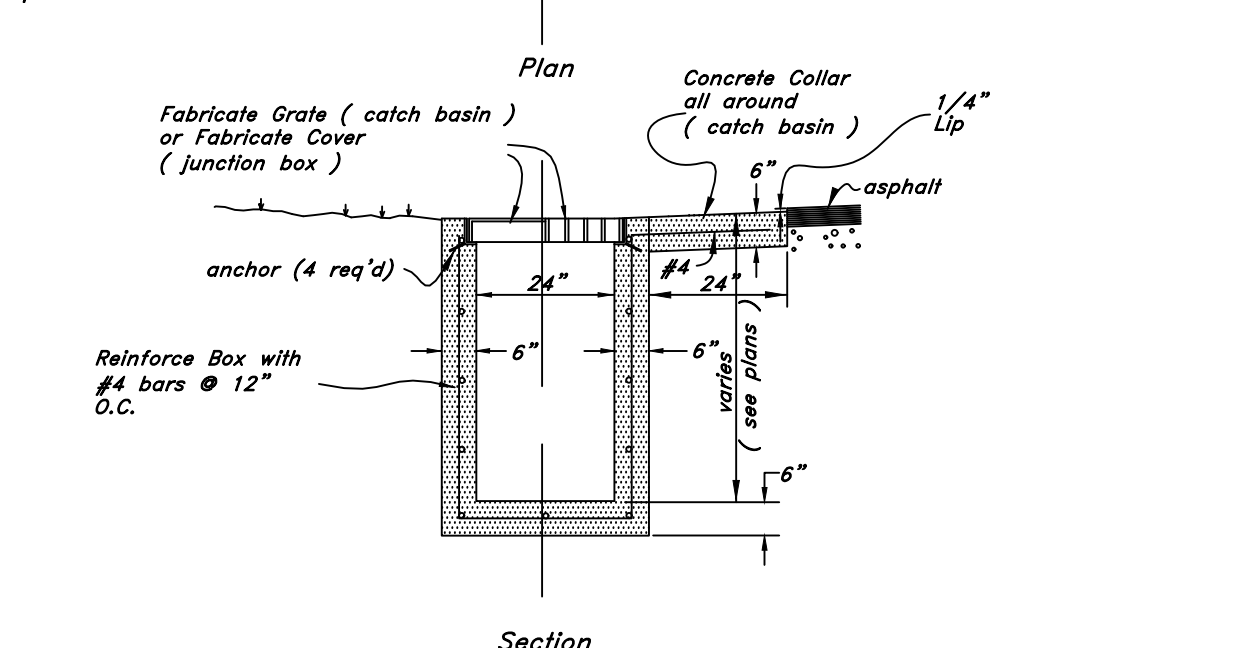
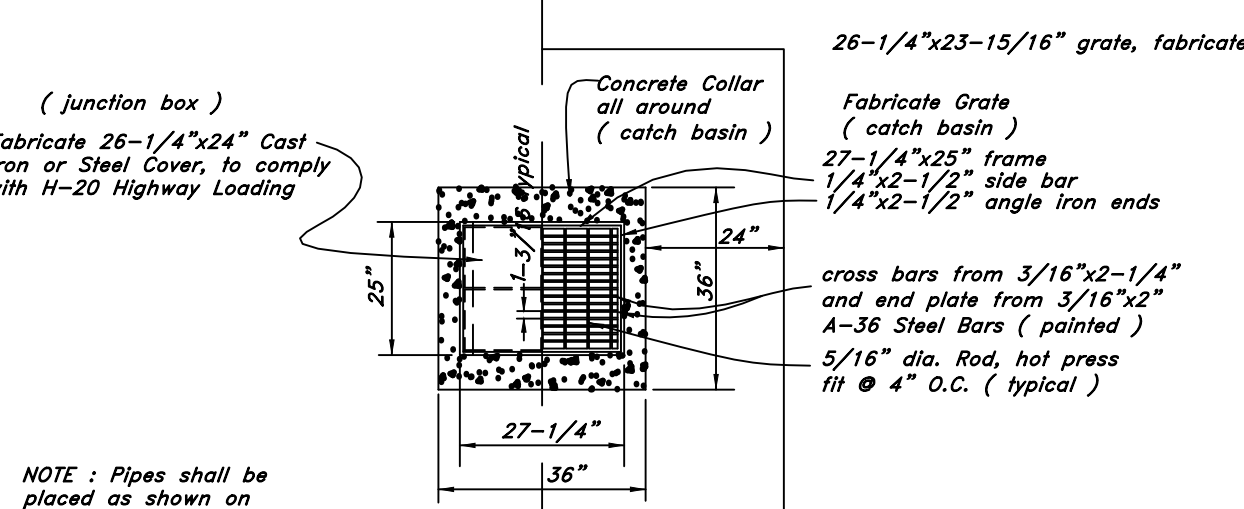

11 Catch Basin/Junction Box

Not to Scale

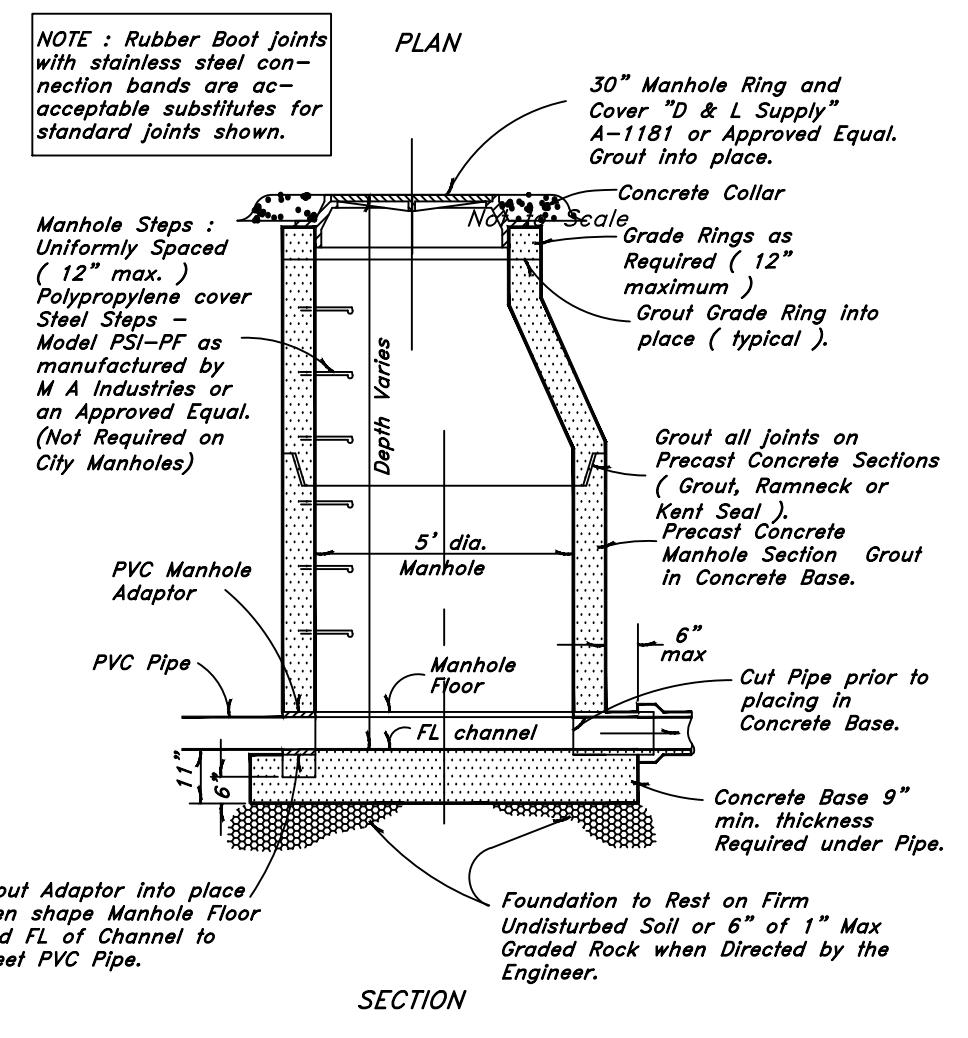
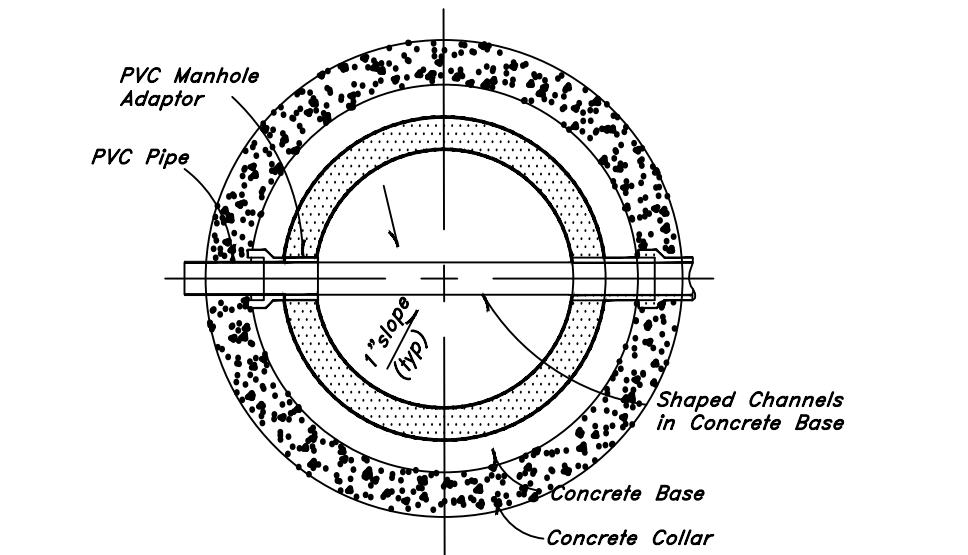

12 Typical Manhole Detail

Not to Scale

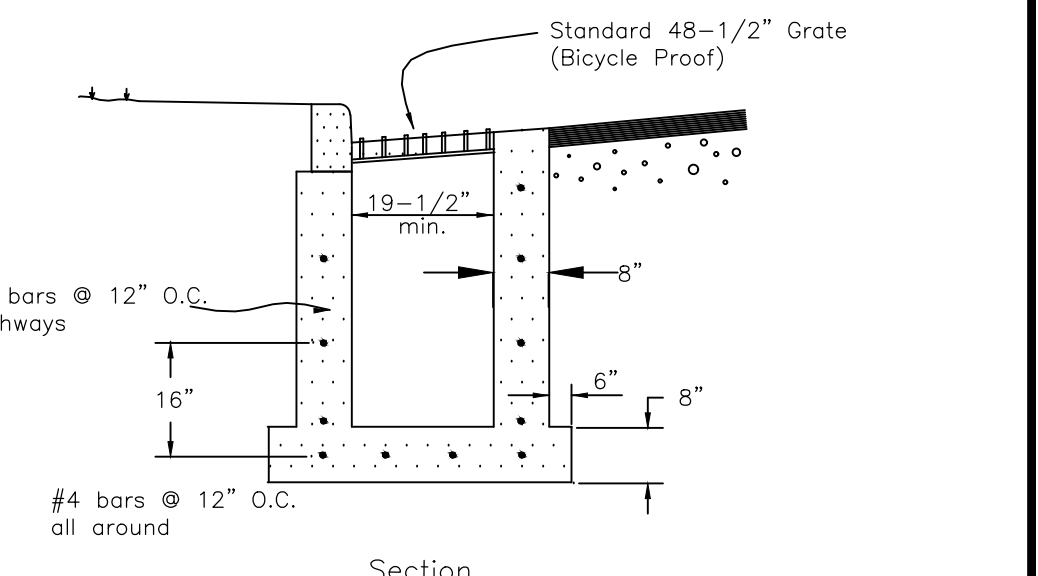
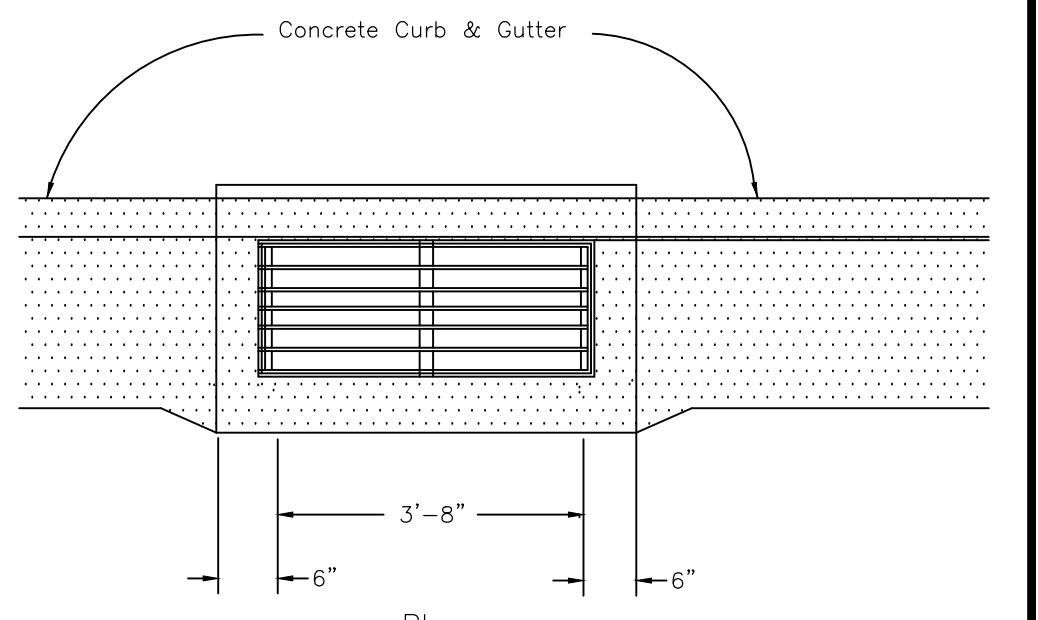

13 Typical Inlet Box

Not to Scale

Landmark Surveying, Inc. A Complete Land Surveying Service www.LandmarkSurveyingUtah.com 4646 South 3500 West - #A-3 West Haven, UT 84401 801-731-4075

CLIENT: Peterson Builders

Parcel ID No 22-159-0007 NW 1/4 of Section 34, Township 7 North, Range 1 East, Salt Lake Base and Meridian.	DRAWN BY: TDK
Revisions:	CHECKED BY: TDK
	DATE: 12/16/2015
	FILE: 3549