

THE RIDGE TOWNHOMES PHASE 2

A PLANNED RESIDENTIAL UNIT DEVELOPMENT (P.R.U.D.)

PART OF THE NORTHEAST 1/4 OF SECTION 27

T7N, R1E, SLB & M, U.S. SURVEY

WEBER COUNTY, UTAH

OCTOBER 2015

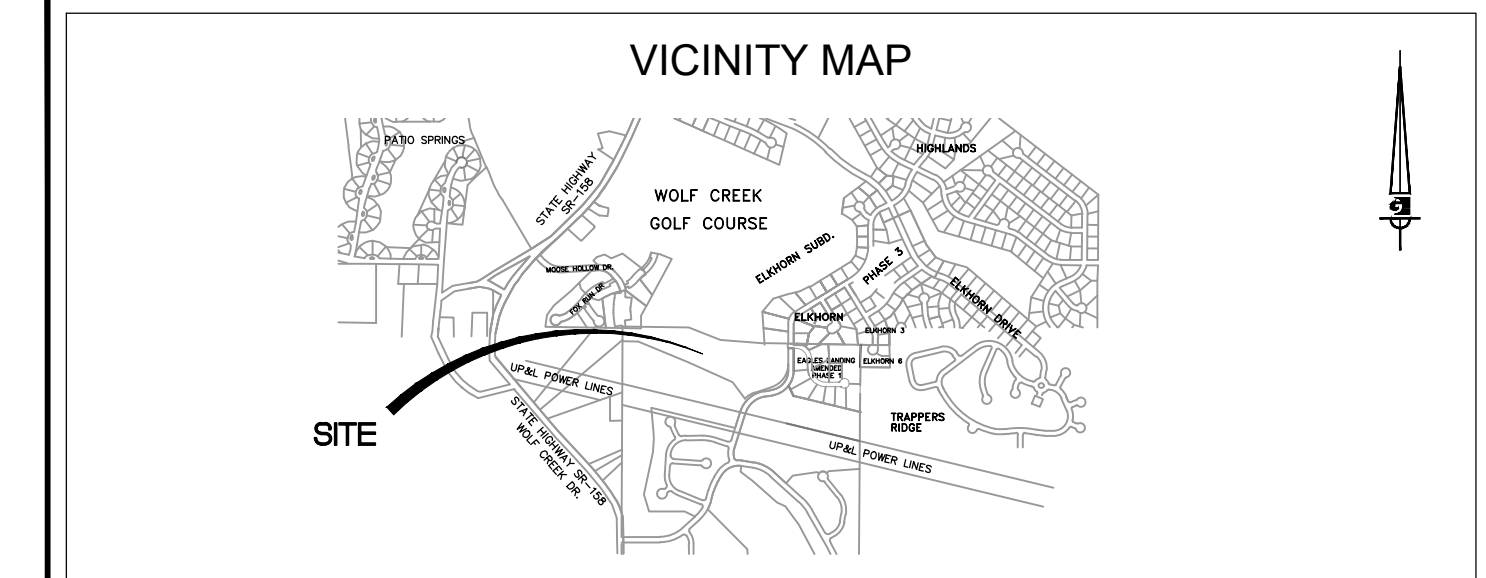

BOUNDARY DESCRIPTION
 A PART OF THE NORTHEAST QUARTER OF SECTION 27, TOWNSHIP 7 NORTH, RANGE 1 EAST, OF THE SALT LAKE BASE AND MERIDIAN.
 BEGINNING AT A POINT ON THE BOUNDARY LINE OF THE RIDGE TOWNHOMES PHASE 1 BEING LOCATED SOUTH 89°09'42" EAST 509.59 FEET ALONG THE NORTH LINE OF SAID NORTHEAST QUARTER AND SOUTH 00°00'00" EAST 88.15 FEET FROM THE NORTHWEST CORNER OF SAID NORTHEAST QUARTER; RUNNING THENCE NORTH 78°09'36" EAST 87.67 FEET; THENCE ALONG THE ARC OF A 430.00 FOOT RADIUS CURVE TO THE RIGHT 410.60 FEET, HAVING A CENTRAL ANGLE OF 54°42'39", CHORD BEARS SOUTH 74°28'35" EAST 395.18 FEET; THENCE SOUTH 47°07'15" EAST 123.87 FEET; THENCE SOUTH 42°52'45" WEST 69.00 FEET; THENCE SOUTH 62°48'50" WEST 48.19 FEET; THENCE NORTH 89°14'42" WEST 39.99 FEET; THENCE NORTH 78°58'27" WEST 55.33 FEET; THENCE NORTH 86°56'20" WEST 83.96 FEET; THENCE NORTH 77°03'57" WEST 120.62 FEET TO THE BOUNDARY LINE OF SAID THE RIDGE TOWNHOMES PHASE 1 THE FOLLOWING SEVEN (7) COURSES: (1) NORTH 03°17'18" WEST 32.67 FEET; (2) NORTH 54°20'13" WEST 71.40 FEET; (3) NORTH 28°07'50" WEST 26.77 FEET; (4) NORTH 70°03'52" WEST 70.68 FEET; (5) SOUTH 17°53'00" WEST 13.00 FEET; (6) NORTH 72°07'00" WEST 22.27 FEET; (7) NORTH 11°49'54" WEST 80.24 FEET TO THE POINT OF BEGINNING.
 CONTAINING 2.084 ACRES.

SURVEYOR'S CERTIFICATE
 I, KLINT WHITNEY, DO HEREBY CERTIFY THAT I AM A LICENSED PROFESSIONAL LAND SURVEYOR IN THE STATE OF UTAH AND THAT I HOLD CERTIFICATE NO. 8227228 IN ACCORDANCE WITH TITLE 58, CHAPTER 22, OF THE PROFESSIONAL ENGINEERS AND LAND SURVEYORS ACT; I FURTHER CERTIFY THAT BY AUTHORITY OF THE OWNERS I HAVE COMPLETED A SURVEY OF THE PROPERTY DESCRIBED ON THIS SUBDIVISION PLAT IN ACCORDANCE WITH SECTION 17-23-17 AND HAVE VERIFIED ALL MEASUREMENTS; THAT THE REFERENCE MONUMENTS SHOWN ON THIS PLAT ARE LOCATED AS INDICATED AND ARE SUFFICIENT TO RETRACE OR REESTABLISH THIS PLAT; AND THAT THE INFORMATION SHOWN HEREIN IS SUFFICIENT TO ACCURATELY ESTABLISH THE LATERAL BOUNDARIES OF THE HEREIN DESCRIBED TRACT OF REAL PROPERTY; AND THAT THIS PLAT OF:
 THE RIDGE TOWNHOMES PHASE 2
 IN WEBER COUNTY, UTAH, HAS BEEN DRAWN CORRECTLY TO THE DESIGNATED SCALE AND IS A TRUE AND CORRECT REPRESENTATION OF THE HEREIN DESCRIBED LANDS INCLUDED IN SAID SUBDIVISION, BASED UPON DATA COMPILED FROM RECORDS IN THE WEBER COUNTY RECORDERS OFFICE; I FURTHER CERTIFY THAT THE REQUIREMENTS OF ALL APPLICABLE STATUTES AND ORDINANCES OF WEBER COUNTY CONCERNING ZONING REQUIREMENTS REGARDING LOT MEASUREMENTS HAVE BEEN COMPLIED WITH.
 SIGNED THIS _____ DAY OF _____, 2015
 KLINT WHITNEY, PLS NO. 8227228

OWNER'S DEDICATION
 RIDGE UTAH DEVELOPMENT CORPORATION (RUDC) AS OWNER OF THE TRACT OF LAND DESCRIBED HEREON, AND AS DECLARANT OF THAT CERTAIN PROJECT KNOWN AS THE RIDGE TOWNHOMES, HEREBY DEDICATES TO PUBLIC USE ALL THOSE PARTS OR PORTIONS OF SAID TRACT OF LAND DESIGNATED AS PUBLIC STREETS, THE SAME TO BE USED AS PUBLIC THOROUGHFARES. RUDC FURTHER DEDICATES AND RESERVES UNTO ITSELF, INCLUDING ITS GRANTEES, SUCCESSORS AND ASSIGNS, A RIGHT-OF-WAY TO BE USED IN COMMON WITH ALL OTHERS WITHIN SAID PROJECT (AND THOSE ADJOINING PROJECTS OR SUBDIVISIONS THAT MAY BE SUBDIVIDED BY SAID OWNER/DECLARANT, ITS GRANTEES, SUCCESSORS OR ASSIGNS) ON OVER AND ACROSS ALL THOSE PORTIONS OR PARTS OF SAID TRACT OF LAND DESIGNATED ON SAID PLAT AS PRIVATE STREETS AS ACCESS TO THE INDIVIDUAL LOTS/UNIT, TO BE MAINTAINED BY THE RIDGE TOWNHOMES ASSOCIATION, WHICH SHALL BE GOVERNED IN ACCORDANCE WITH THE UTAH COMMUNITY ASSOCIATION ACT AND WHOM MEMBERSHIP SHALL CONSIST OF THE OWNERS OF SAID LOTS/UNITS, THEIR GRANTEES, SUCCESSORS, OR ASSIGNS. RUDC ALSO GRANTS AND CONVEYS TO THE RIDGE TOWNHOMES ASSOCIATION ALL THOSE PARTS OR PORTIONS OF SAID TRACT OF LAND DESIGNATED AS COMMON AREAS TO BE USED FOR RECREATIONAL AND OPEN SPACE PURPOSES FOR THE BENEFIT OF EACH RIDGE TOWNHOMES ASSOCIATION MEMBER IN COMMON WITH ALL OTHERS IN THE PROJECT.
 RUDC GRANTS AND DEDICATES TO WEBER COUNTY A PERPETUAL EASEMENT ON AND OVER THE COMMON AREAS TO GUARANTEE TO WEBER COUNTY THAT THE COMMON AREAS REMAIN OPEN AND UNDEVELOPED EXCEPT FOR APPROVED RECREATIONAL, PARKING AND OPEN SPACE PURPOSES. RUDC ALSO GRANTS AND DEDICATES TO WEBER COUNTY A PERPETUAL EASEMENT FOR PROVIDING AND MAINTAINING CONSTRUCTION CUT AND/OR FILL SLOPES, LATERAL SUPPORT AND/OR PROPER DRAINAGE ADJACENT TO THE PUBLIC RIGHT-OF-WAY LOCATED WITHIN THE PROJECT.
 RUDC GRANTS AND DEDICATES A PERPETUAL RIGHT AND EASEMENT FOR PUBLIC UTILITY PURPOSES OVER, UPON AND UNDER THE PROJECT.
 A. STORM WATER DETENTION PONDS, DRAINAGE EASEMENTS AND CANAL MAINTENANCE EASEMENT THE SAME TO BE USED FOR THE INSTALLATION MAINTENANCE AND OPERATION OF PUBLIC UTILITY SERVICE LINES, STORM DRAINAGE FACILITIES, IRRIGATION CANALS OR FOR THE PERPETUAL PRESERVATION OF WATER CHANNELS IN THEIR NATURAL STATE WHICHEVER IS APPLICABLE AS MAY BE AUTHORIZED BY THE GOVERNING AUTHORITY, WITH NO BUILDINGS OR STRUCTURES BEING ERRECTED WITHIN SUCH EASEMENTS.
 B. PRIVATE OWNERSHIP WILL BE DEFINED AS ANYTHING WITHIN THE FOOTPRINT OF THE INDIVIDUAL LOTS/UNITS AS SHOWN ON SHEET 3.
 C. LIMITED COMMON AREA TO BE EXCLUDED FROM PUBLIC UTILITY EASEMENT DEDICATION.
 RIDGE UTAH DEVELOPMENT CORPORATION
 SIGNED THIS _____ DAY OF _____, 2015
 ERIC S HOUSEHOLDER OFFICER
 RIDGE TOWNHOMES ASSOCIATION
 SIGNED THIS _____ DAY OF _____, 2015
 ERIC S HOUSEHOLDER OFFICER

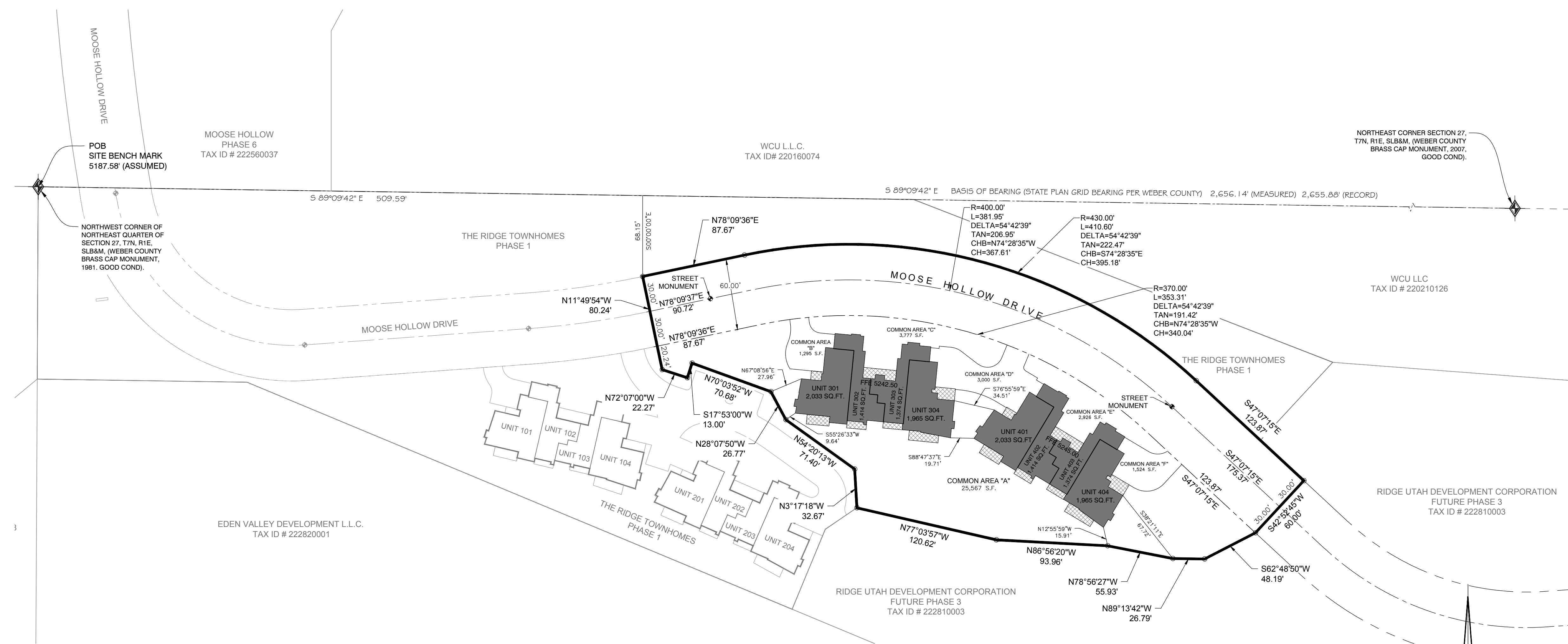

LEGEND

- SECTION CORNER MONUMENT
- SET #5 BY 24" REBAR AND CAP STAMPED GARDNER ENGINEERING
- STREET MONUMENT
- SECTION LINE
- CENTERLINE
- RIGHT-OF-WAY LINE
- PROPERTY BOUNDARY
- BUILDING TIES
- PRIVATE
- LIMITED COMMON AREA
- COMMON AREA

ADDRESS TABLE

UNIT 301	5209 EAST
UNIT 302	5211 EAST
UNIT 303	5217 EAST
UNIT 304	5219 EAST
UNIT 401	5223 EAST
UNIT 402	5235 EAST
UNIT 403	5239 EAST
UNIT 404	5241 EAST

NARRATIVE:
 THE PURPOSE OF THIS SURVEY WAS TO CREATE A P.R.U.D. SUBDIVISION PLAT OF THE PROPERTY AS SHOWN AND DESCRIBED HEREON. THE SURVEY WAS ORDERED BY JOHN L. LEWIS. THE CONTROL USED TO ESTABLISH THE BOUNDARY WAS THE EXISTING WEBER COUNTY SURVEY MONUMENTS SURROUNDING SECTION 27, TOWNSHIP 7 NORTH, RANGE 1 EAST OF THE SALT LAKE BASE AND MERIDIAN. THE BASIS OF BEARING IS THE NORTH LINE OF THE NORTHEAST QUARTER OF SAID SECTION WHICH BEARS SOUTH 89°09'42" EAST 2656.14 FEET WEBER COUNTY, NAD 83, STATE PLANE GRID BEARING.

SITE SUMMARY:
 TOTAL AREA = 90,766.83 SQ. FT.
 BUILDING COVERAGE = 13,793.43 SQ. FT.
 HARD SURFACE AREA = 5,819.00 SQ. FT.
 LANDSCAPED AREA = 32,272.00 SQ. FT.
 DEDICATED ROAD AREA = 38,882.40 SQ. FT.

OWNER:
 RIDGE UTAH DEVELOPMENT CORPORATION
 JOHN L. LEWIS
 3718 NORTH WOLF CREEK DRIVE
 EDEN, UTAH 84310
 (801) 430-1507

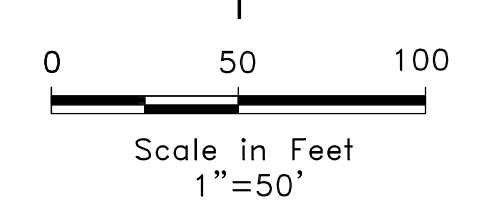

WEBER COUNTY PLANNING COMMISSION APPROVAL
 THIS IS TO CERTIFY THAT THIS SUBDIVISION PLAT WAS DULY APPROVED BY THE WEBER COUNTY PLANNING COMMISSION ON THE _____ DAY OF _____, 2015
 CHAIRMAN, WEBER COUNTY PLANNING COMMISSION

WEBER COUNTY SURVEYOR
 I HEREBY CERTIFY THAT THE WEBER COUNTY SURVEYOR'S OFFICE HAS REVIEWED THIS PLAT FOR MATHEMATICAL CORRECTNESS, SECTION CORNER DATA, AND FOR HARMONY WITH LINES AND MONUMENTS ON RECORD IN COUNTY OFFICES. THE APPROVAL OF THIS PLAT BY THE WEBER COUNTY SURVEYOR DOES NOT RELIEVE THE LICENSED LAND SURVEYOR WHO EXECUTE THIS PLAT FROM THE RESPONSIBILITIES AND/OR LIABILITIES ASSOCIATED THEREWITH.
 SIGNED THIS _____ DAY OF _____, 2015
 SIGNATURE

WEBER COUNTY COMMISSION ACCEPTANCE
 THIS IS TO CERTIFY THAT THIS SUBDIVISION PLAT, THE DEDICATION OF STREETS AND OTHER PUBLIC WAYS AND FINANCIAL GUARANTEE OF PUBLIC IMPROVEMENTS ASSOCIATED WITH THIS SUBDIVISION, THEREON ARE HEREBY APPROVED AND ACCEPTED BY THE COMMISSIONERS OF WEBER COUNTY, UTAH
 THIS _____ DAY OF _____, 2015
 CHAIRMAN, WEBER COUNTY COMMISSION

WEBER - MORGAN HEALTH DEPARTMENT
 I DO HEREBY CERTIFY THAT THE SOILS, PERCOLATION RATES, AND SITE CONDITION FOR THIS SUBDIVISION HAVE BEEN INVESTIGATED BY THIS OFFICE AND ARE APPROVED FOR ON-SITE WASTEWATER DISPOSAL SYSTEMS.
 THIS _____ DAY OF _____, 2015
 DIRECTOR WEBER-MORGAN HEALTH DEPARTMENT

ACKNOWLEDGMENT
 STATE OF UTAH)
 COUNTY OF WEBER) SS
 ON THIS _____ DAY OF _____, 2015,
 PERSONALLY APPEARED BEFORE ME, ERIC S HOUSEHOLDER, THE SIGNER OF THE ABOVE OWNERS DEDICATION, WHO DULY ACKNOWLEDGED TO ME HE SIGNED IT FREELY AND VOLUNTARILY AND FOR THE PURPOSES THEREIN MENTIONED.
 STAMP
 NOTARY PUBLIC

WEBER COUNTY ATTORNEY
 I HAVE EXAMINED THE FINANCIAL GUARANTEE AND OTHER DOCUMENTS ASSOCIATED WITH THIS SUBDIVISION PLAT AND IN MY OPINION THEY CONFORM WITH THE COUNTY ORDINANCE APPLICABLE THERETO AND NOW IN FORCE AND AFFECT.
 SIGNED THIS _____ DAY OF _____, 2015
 SIGNATURE

WEBER COUNTY ENGINEER
 I HEREBY CERTIFY THAT THE REQUIRED PUBLIC IMPROVEMENT STANDARDS AND DRAWINGS FOR THIS SUBDIVISION CONFORM WITH COUNTY STANDARDS AND THE AMOUNT OF THE FINANCIAL GUARANTEE IS SUFFICIENT FOR THE INSTALLATION OF THESE IMPROVEMENTS.
 SIGNED THIS _____ DAY OF _____, 2015
 SIGNATURE

ATTEST: _____
 TITLE: _____

SHEET 1 OF 4

Prepared By: **GARDNER ENGINEERING**
 CIVIL - LAND PLANNING
 MUNICIPAL - LAND SURVEYING
 5150 SOUTH 375 EAST OGDEN, UT
 OFFICE: 801.476.0202 FAX: 801.476.0066
 www.gardnerengineering.net

COUNTY RECORDER
 ENTRY NO. _____ FEE PAID _____
 FILED FOR RECORD AND
 RECORDED _____ AT
 IN _____ BOOK OF OFFICIAL
 RECORDS, PAGE _____ RECORDED
 FOR _____
 COUNTY RECORDER
 BY: _____ DEPUTY

THE RIDGE TOWNHOMES PHASE 2

PART OF THE NORTHEAST 1/4 OF SECTION 27
T7N, R1E, SLB & M, U.S. SURVEY
WEBER COUNTY, UTAH
SEPTEMBER 2015



LINE #	LENGTH	BEARING
L1	0.667	N5° 34' 36"E
L2	15.713	N84° 25' 24"W
L3	5.000	N5° 34' 36"E
L4	30.406	N84° 25' 24"W
L5	3.792	S5° 34' 36"W
L6	2.635	N84° 25' 24"W
L7	1.792	N5° 34' 36"E
L8	13.830	N84° 25' 24"W
L9	3.000	S5° 34' 36"W
L10	14.917	N84° 25' 24"W
L11	5.042	N5° 34' 36"E
L12	29.303	N84° 25' 24"W
L13	5.505	N10° 34' 36"E
L14	2.208	N79° 25' 24"W
L15	6.250	N10° 34' 36"E
L16	2.208	S79° 25' 24"E
L17	5.918	N10° 34' 36"E
L18	0.208	N79° 25' 24"W
L19	11.786	N10° 34' 36"E
L20	16.659	S84° 25' 24"E
L21	5.989	N5° 34' 36"E
L22	0.994	S84° 25' 24"E
L23	22.272	N5° 34' 36"E
L24	6.833	S84° 25' 24"E
L25	12.459	N5° 34' 36"E
L26	13.839	S84° 25' 24"E
L27	0.999	N5° 34' 36"E
L28	7.740	S84° 25' 24"E
L29	0.999	S5° 34' 36"W
L30	2.837	S84° 24' 36"E
L31	12.458	S5° 34' 36"W
L32	2.500	S84° 25' 24"E
L33	22.458	S5° 34' 36"W
L34	10.322	S84° 25' 24"E
L35	3.833	N5° 34' 36"E
L36	7.917	S84° 25' 24"E
L37	3.833	S5° 34' 36"W
L38	9.460	S84° 25' 24"E
L39	19.185	N5° 34' 36"E
L40	2.589	S84° 25' 25"E
L41	12.437	N5° 34' 36"E
L42	4.562	S84° 25' 24"E
L43	2.000	N5° 34' 36"E
L44	10.208	S84° 25' 24"E

LINE #	LENGTH	BEARING
L45	2.000	S5° 34' 36"W
L46	9.542	S84° 25' 24"E
L47	12.437	S5° 34' 36"W
L48	6.937	S84° 25' 24"E
L49	22.917	S5° 34' 36"W
L50	2.558	N84° 25' 24"W
L51	2.954	S5° 34' 36"W
L52	5.110	S84° 25' 24"E
L53	4.926	S5° 34' 36"W
L54	14.619	S84° 25' 24"E
L55	17.347	S5° 34' 36"W
L56	2.042	S84° 25' 24"E
L57	6.250	S5° 34' 36"W
L58	2.250	N84° 25' 24"W
L59	7.894	S5° 34' 36"W
L60	25.556	N79° 25' 24"W
L61	0.667	N31° 04' 05"E
L62	15.713	N58° 55' 55"W
L63	5.000	N31° 04' 05"E
L64	30.406	N58° 55' 55"W
L65	3.792	S31° 04' 05"W
L66	2.635	N58° 55' 55"W
L67	1.792	N31° 04' 05"E
L68	13.830	N58° 55' 55"W
L69	3.000	S31° 04' 05"W
L70	14.917	N58° 55' 55"W
L71	5.042	N31° 04' 05"E
L72	29.303	N58° 55' 55"W
L73	5.505	N36° 04' 05"E
L74	2.208	N53° 55' 55"W
L75	6.250	N36° 04' 05"E
L76	2.208	S53° 55' 55"E
L77	5.918	N36° 04' 05"E
L78	0.208	N53° 55' 55"W
L79	11.786	N36° 04' 05"E
L80	16.659	S58° 55' 55"E
L81	5.989	N31° 04' 05"E
L82	0.994	S58° 55' 55"E
L83	22.272	N31° 04' 05"E
L84	6.833	S58° 55' 55"E
L85	12.459	N31° 04' 05"E
L86	13.839	S58° 55' 55"E
L87	0.999	N31° 04' 05"E
L88	7.740	S58° 55' 55"E

LINE #	LENGTH	BEARING
L89	0.999	S31° 04' 05"W
L90	2.837	S58° 55' 08"E
L91	12.458	S31° 04' 05"W
L92	2.500	S58° 55' 55"E
L93	22.458	S31° 04' 05"W
L94	10.322	S58° 55' 55"E
L95	3.833	N31° 04' 05"E
L96	7.917	S58° 55' 55"E
L97	3.833	S31° 04' 05"W
L98	9.460	S58° 55' 55"E
L99	19.185	N31° 04' 05"E
L100	2.589	S58° 55' 57"E
L101	12.437	N31° 04' 05"E
L102	4.562	S58° 55' 55"E
L103	2.000	N31° 04' 05"E
L104	10.208	S58° 55' 55"E
L105	2.000	S31° 04' 05"W
L106	9.542	S58° 55' 55"E
L107	12.437	S31° 04' 05"W
L108	6.937	S58° 55' 55"E
L109	22.917	S31° 04' 05"W
L110	2.558	N58° 55' 55"W
L111	2.954	S31° 04' 05"W
L112	5.110	S58° 55' 55"E
L113	4.926	S31° 04' 05"W
L114	14.619	S58° 55' 55"E
L115	17.347	S31° 04' 05"W
L116	2.042	S58° 55' 55"E
L117	6.250	S31° 04' 05"W
L118	2.250	N58° 55' 55"W
L119	7.894	S31° 04' 05"W
L120	25.556	N53° 55' 55"W
L121	19.214	S84° 25' 24"E
L122	8.046	S5° 34' 36"W
L123	19.213	N84° 26' 01"W
L124	8.049	N5° 33' 59"E
L125	9.881	N84° 26' 01"W
L126	7.461	S5° 33' 59"W
L127	27.698	S84° 26' 01"E
L128	2.126	N5° 34' 36"E
L129	17.104	S84° 26' 01"E
L130	10.010	S5° 11' 38"W
L131	15.436	S79° 25' 24"E
L132	6.142	S5° 33' 59"W

LINE #	LENGTH	BEARING
L133	25.083	N84° 26' 01"W
L134	8.158	N5° 33' 59"E
L135	9.707	S84° 25' 24"E
L136	5.159	S5° 33' 59"W
L137	16.547	N84° 26' 01"W
L138	5.162	N5° 33' 59"E
L139	16.547	S84° 25' 24"E
L140	4.233	S5° 34' 36"W
L141	16.465	N84° 26' 01"W
L142	6.027	N5° 34' 36"E
L143	8.046	S31° 04' 05"W
L144	19.213	N58° 56' 33"W
L145	8.049	N31° 03' 27"E
L146	19.214	S58° 55' 55"E
L147	1.465	N31° 04' 05"E
L148	9.881	N58° 53' 17"W
L149	7.461	S31° 03' 27"W
L150	27.698	S58° 56' 33"E
L151	2.475	N31° 04' 05"E
L152	17.101	S59° 09' 33"E
L153	10.424	S30° 41' 07"W
L154	15.436	S53° 55' 55"E
L155	6.142	S31° 03' 27"W
L156	25.083	N58° 56' 33"W
L157	8.158	N31° 03' 27"E
L158	9.707	S58° 55' 55"E
L159	0.159	S31° 03' 27"W
L160	16.547	N58° 56' 33"W
L161	5.162	N31° 03' 27"E
L162	16.547	S58° 55' 55"E
L163	5.159	S31° 04' 04"W
L164	4.233	S31° 04' 05"W
L165	16.465	N58° 56' 33"W
L166	6.027	N31° 04' 05"E
L167	0.296	S5° 33' 59"W
L168	17.300	S84° 26' 01"E
L169	59.374	S5° 34' 36"W
L170	0.075	S84° 25' 24"E
L171	15.463	N5° 33' 59"E
L172	6.763	N84° 26' 01"W
L173	6.667	N5° 33' 59"E
L174	7.156	N84° 26' 01"W
L175	13.082	N5° 33' 59"E
L176	0.281	S5° 33' 59"W

LINE #	LENGTH	BEARING
L177	16.883	N84° 26' 01"W
L178	54.109	S5° 34' 36"W
L179	0.388	N84° 25' 24"W
L180	0.296	S31° 03' 27"W
L181	17.300	S58° 56' 33"E
L182	59.374	S31° 04' 05"W
L183	0.075	S58° 55' 55"E
L184	13.082	S31° 03' 27"W
L185	7.156	S58° 56' 33"E
L186	6.667	S31° 03' 27"W
L187	6.763	S58° 56' 33"E
L188	15.463	S31° 03' 27"W
L189	0.281	S31° 03' 27"W
L190	16.883	N58° 56' 33"W
L191	54.109	S31° 03' 27"W
L192	0.388	N58° 55' 55"W

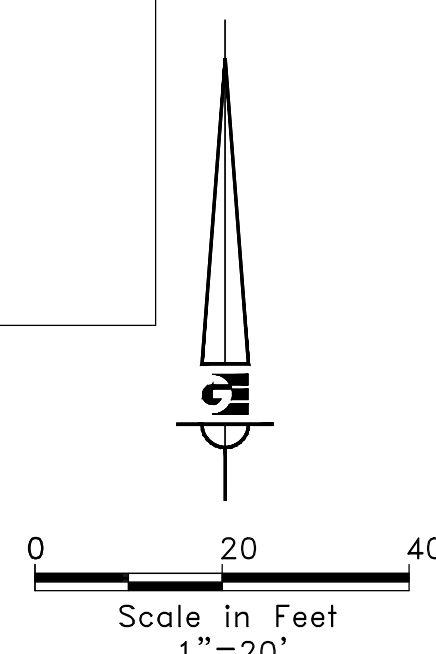

LEGEND

-----	SECTION LINE
-----	CENTERLINE
-----	RIGHT-OF-WAY LINE
-----	PROPERTY BOUNDARY
-----	PUBLIC UTILITY EASEMENT (PUE)
-----	BUILDING TIES
█	PRIVATE
▨	LIMITED COMMON AREA
□	COMMON AREA

Prepared By:

SHEET 2 OF 4

COUNTY RECORDER

ENTRY NO. _____ FEE PAID _____

RECORDED _____ FILED FOR RECORD AND _____ AT _____

IN _____ BOOK OF OFFICIAL RECORDS, PAGE _____ RECORDED _____

FOR _____

BY: _____ COUNTY RECORDER

DEPUTY _____

www.gardnerengineering.net

THE RIDGE TOWNHOMES

PHASE 2

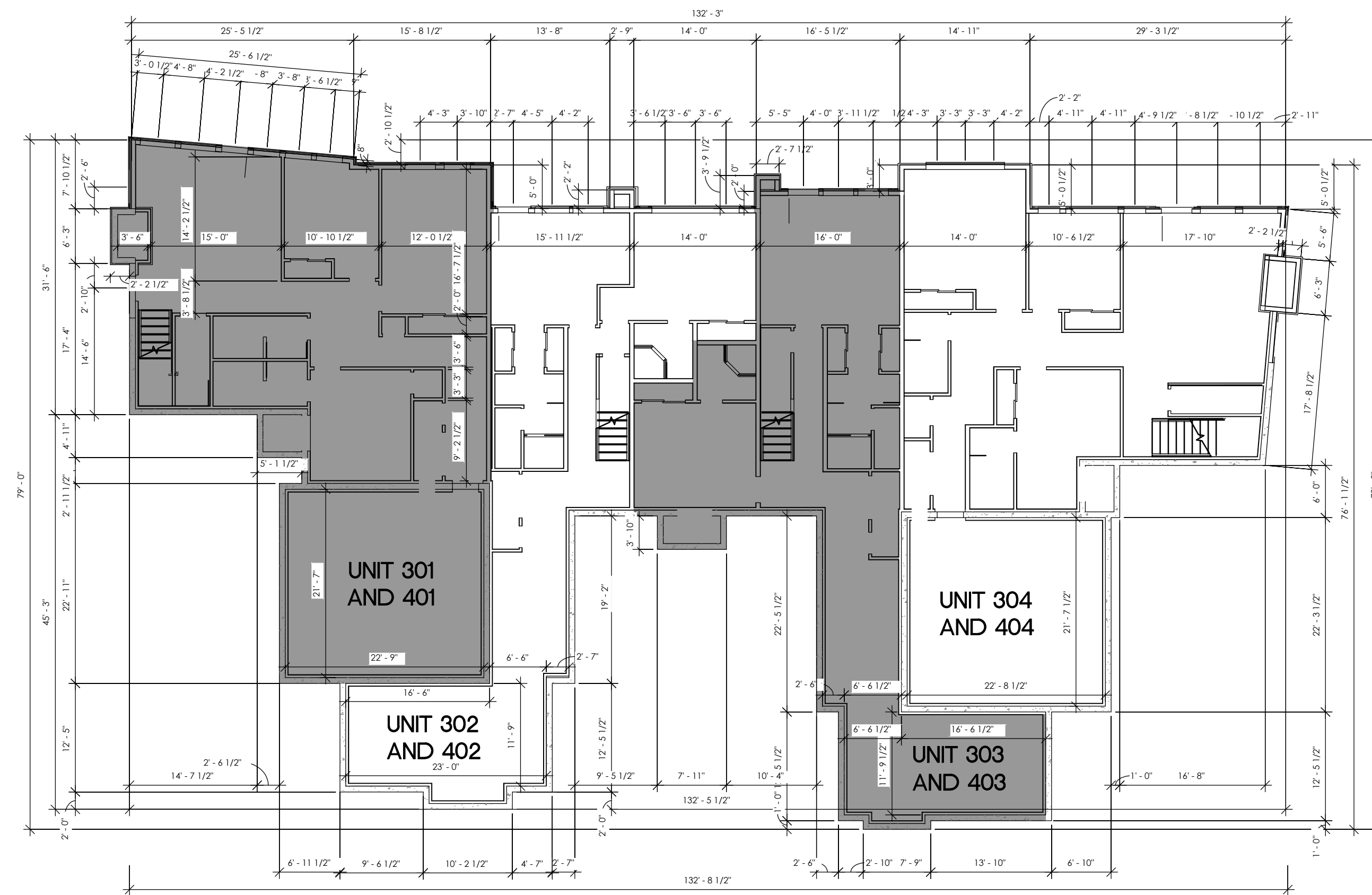

LOWER LEVEL
FLOOR PLAN

NOTE: EACH 'LOT' IS IDENTIFIED BY THE BOUNDARIES OF THE ENTIRE LOWER LEVEL OF EACH UNIT AS DEPICTED ON THE LOWER LEVEL FLOOR PLAN.

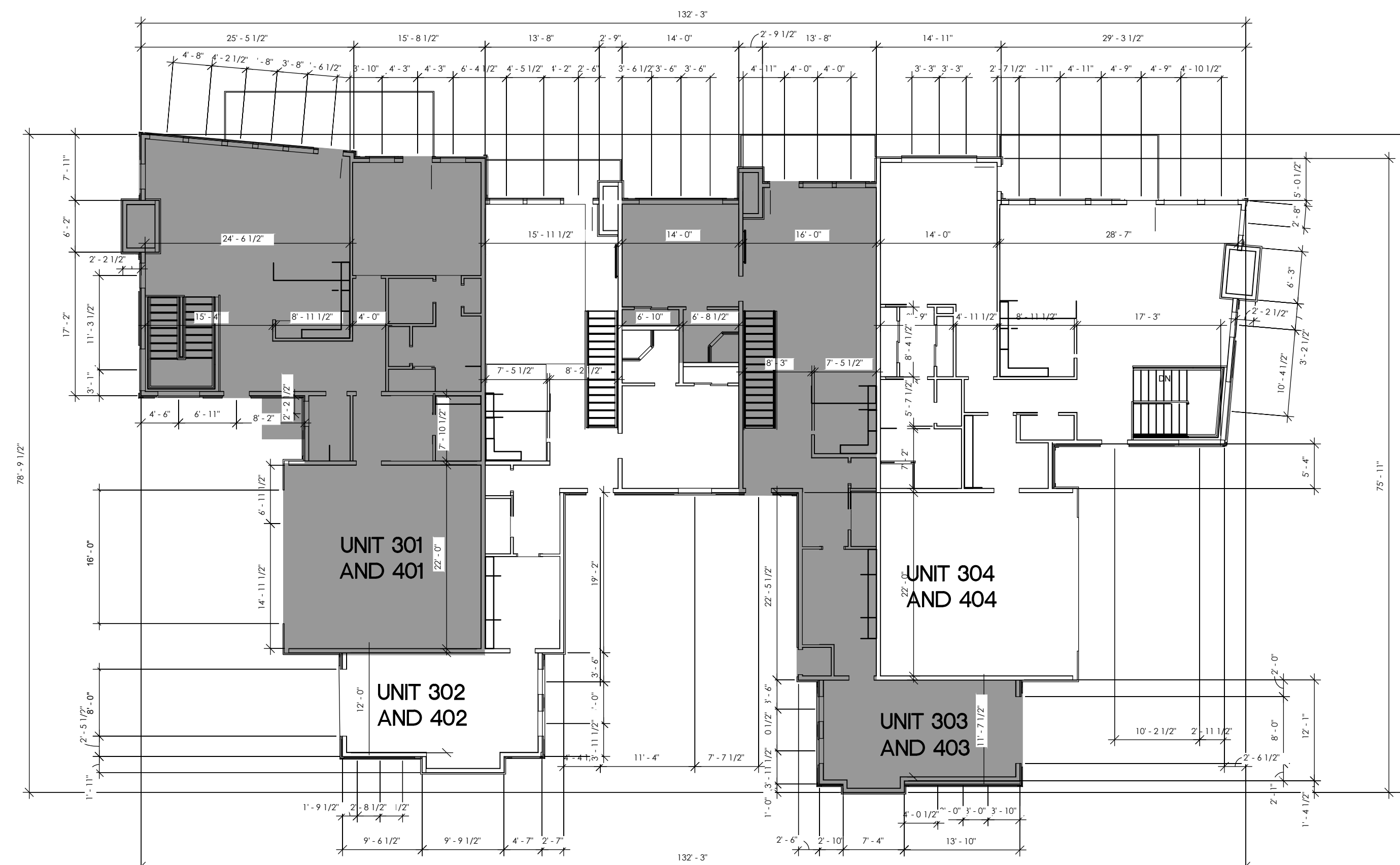

MAIN LEVEL
FLOOR PLAN

Prepared By:



www.gardnerengineering.net

COUNTY RECORDER

ENTRY NO. _____ FEE PAID _____
 _____ FILED FOR RECORD AND
 RECORDED _____ AT _____
 IN _____ BOOK OF OFFICIAL
 RECORDS, PAGE _____ RECORDED
 FOR _____
 _____ COUNTY RECORDER
 BY: _____ DEPUTY

THE RIDGE TOWNHOMES

PHASE 2



SOUTH ELEVATION
 BUILDINGS 301-304 100'-00" = 5242.50
 BUILDINGS 401-404 100'-00" = 5245.00

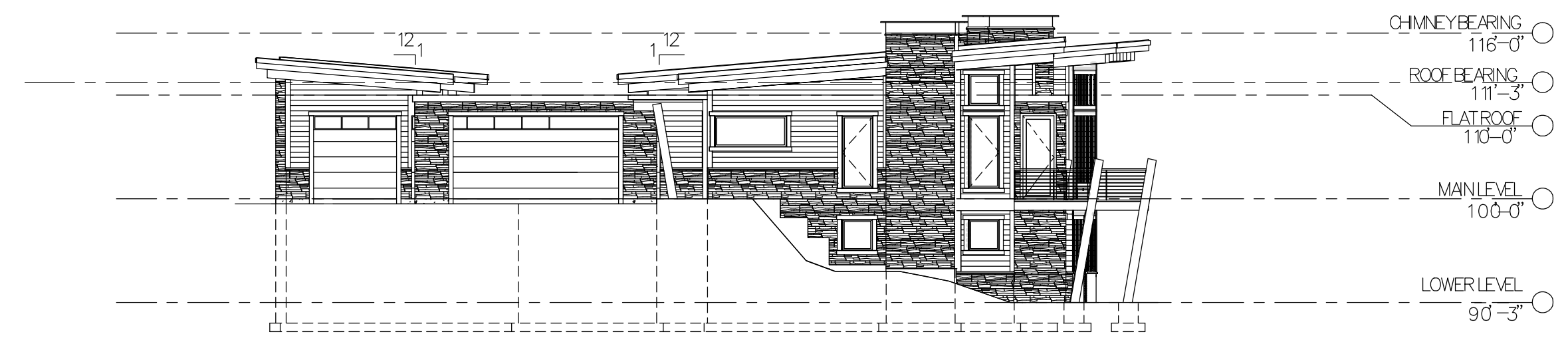

WEST ELEVATION
 BUILDINGS 301-304 100'-00" = 5242.50
 BUILDINGS 401-404 100'-00" = 5245.00

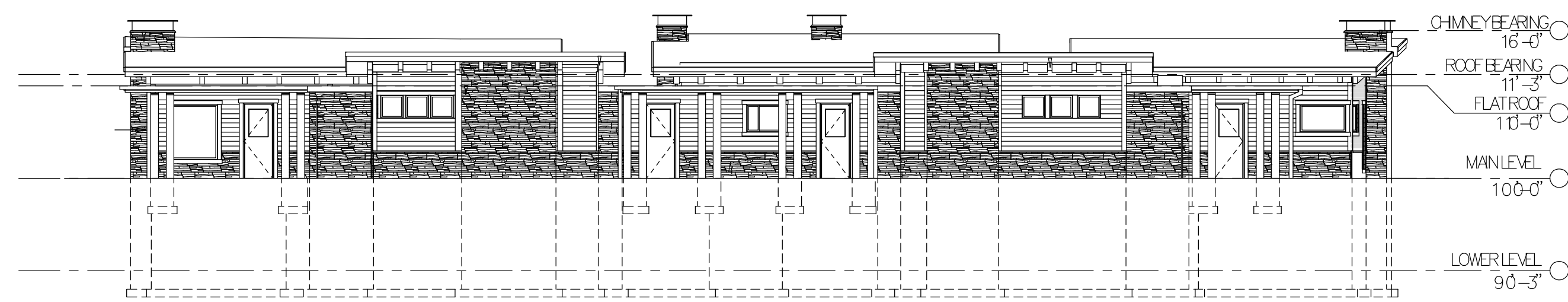

NORTH ELEVATION
 BUILDINGS 301-304 100'-00" = 5242.50
 BUILDINGS 401-404 100'-00" = 5245.00

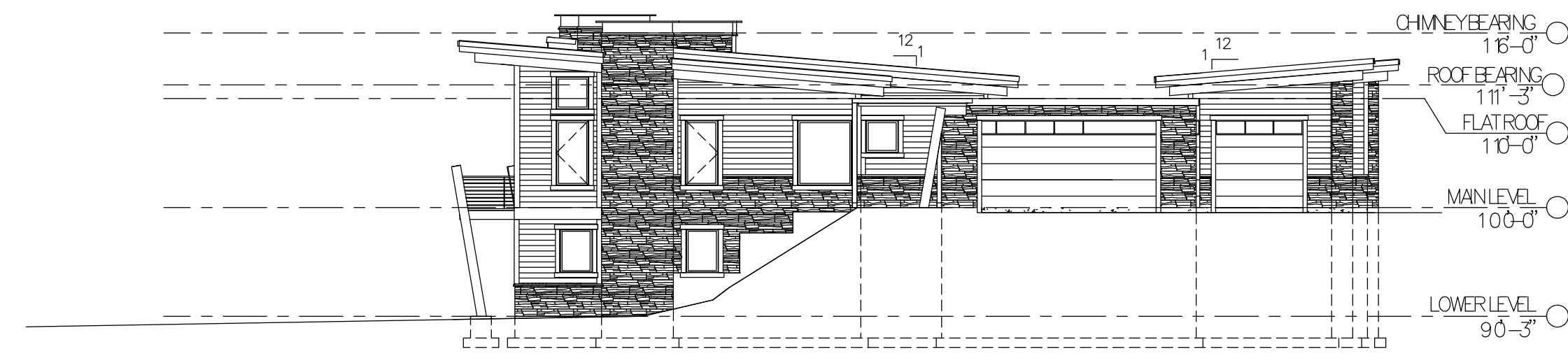

EAST ELEVATION
 BUILDINGS 301-304 100'-00" = 5242.50
 BUILDINGS 401-404 100'-00" = 5245.00

SHEET 4 OF 4

Prepared By: <div style="text-align: center; margin-top: 10px;"> <p style="font-size: small; margin: 0;"> CIVIL - LAND PLANNING MUNICIPAL - LAND SURVEYING 5150 SOUTH 375 EAST OGDEN, UT OFFICE: 801.476.0202 FAX: 801.476.0066 www.gardnerengineering.net </p> </div>	<p style="text-align: center; font-weight: bold; font-size: small;">COUNTY RECORDER</p> ENTRY NO. _____ FEE PAID _____ _____ FILED FOR RECORD AND RECORDED _____ AT IN _____ BOOK OF OFFICIAL RECORDS, PAGE _____ RECORDED FOR _____ _____ COUNTY RECORDER BY: _____ DEPUTY
--	--

THE RIDGE TOWNHOMES PHASE 2

PART OF THE NORTHEAST 1/4 OF SECTION 27
T7N, R1E, SLB & M, U.S. SURVEY
WEBER COUNTY, UTAH
SEPTEMBER 2015



LINE TABLE		
LINE #	LENGTH	BEARING
L193	4.416	S6° 30' 38"E
L195	12.711	S84° 26' 01"E
L196	11.861	S22° 39' 34"W
L198	17.813	N52° 31' 13"W
L200	9.914	N84° 26' 01"W
L201	2.000	S5° 05' 27"W
L202	7.007	N84° 26' 01"W
L203	9.344	N59° 09' 33"W
L205	4.011	N84° 26' 01"W
L206	11.117	S22° 39' 34"W
L208	12.059	S59° 09' 33"E
L209	2.000	S30° 50' 27"W
L210	6.997	S59° 09' 33"E
L211	23.539	N59° 09' 33"W
L212	22.147	S42° 52' 45"W
L214	5.018	N59° 09' 33"W
L225	4.379	S6° 30' 38"E
L228	28.151	S84° 26' 01"E

CURVE TABLE					
CURVE #	LENGTH	RADIUS	DELTA	CHORD BEARING	CHORD LENGTH
C1	15.60	30.00	29.80	S8° 23' 15"W	15.43
C2	22.90	23.46	55.93	S4° 40' 43"E	22.00
C3	13.60	10.00	77.92	S45° 28' 19"E	12.58
C4	23.78	13.00	104.82	S75° 04' 10"W	20.60
C5	9.47	17.00	31.91	N68° 28' 37"W	9.35
C6	4.28	3.00	81.82	S18° 15' 00"E	3.93
C7	32.86	74.50	25.27	N71° 47' 47"W	32.60
C8	16.78	15.00	64.10	S88° 47' 30"W	15.92
C9	27.21	20.00	77.96	S81° 51' 36"W	25.16

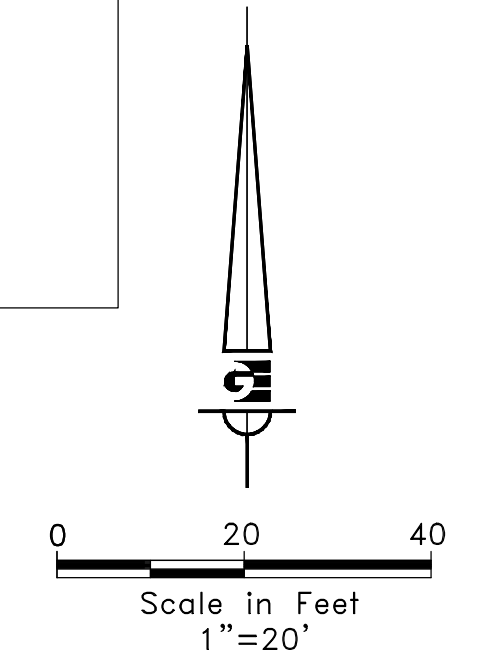

LEGEND	
	SECTION LINE
	CENTERLINE
	RIGHT-OF-WAY LINE
	PROPERTY BOUNDARY
	PUBLIC UTILITY EASEMENT (PUE)
	BUILDING TIES
	PRIVATE
	LIMITED COMMON AREA
	COMMON AREA

Prepared By:

GARDNER ENGINEERING
CIVIL - LAND PLANNING
MUNICIPAL - LAND SURVEYING
5150 SOUTH 375 EAST OGDEN, UT
OFFICE: 801.476.0202 FAX: 801.476.0066
www.gardnerengineering.net

SHEET 5 OF 5

COUNTY RECORDER

ENTRY NO. _____ FEE PAID _____

RECORDED _____ FILED FOR RECORD AND

RECORDED _____ AT _____

IN _____ BOOK OF OFFICIAL

RECORDS, PAGE _____ RECORDED

FOR _____

BY: _____ COUNTY RECORDER

DEPUTY