

THE RIDGE TOWNHOMES PHASE 1 - 1ST AMENDMENT A PLANNED RESIDENTIAL UNIT DEVELOPMENT (P.R.U.D.)

PART OF THE NORTHEAST 1/4 OF SECTION 27
T7N, R1E, SLB & M, U.S. SURVEY
WEBER COUNTY, UTAH
JUNE 2015

LINE TABLE		
LINE #	LENGTH	BEARING
L248	15.758	N76° 41' 09"W
L250	7.012	S13° 18' 51"W
L251	14.316	S76° 41' 09"E
L252	53.352	N54° 20' 13"W
L253	15.924	N19° 22' 23"E
L254	14.974	S19° 22' 23"W
L255	15.003	N17° 53' 00"E
L256	31.000	N72° 07' 00"W
L257	15.000	S17° 53' 00"W
L259	8.467	N72° 07' 00"W
L260	1.126	N10° 29' 10"W
L261	29.160	N66° 05' 07"W
L263	3.188	S72° 07' 00"E
L265	52.885	S54° 20' 13"E
L267	9.382	N66° 05' 07"W
L268	28.554	N76° 41' 09"W
L269	4.935	S76° 41' 09"E
L270	16.834	S17° 53' 00"W
L271	20.000	S72° 07' 00"E
L272	6.329	N17° 53' 00"E
L273	11.250	S66° 05' 07"E
L307	8.718	S66° 05' 07"E
L309	0.089	N4° 09' 59"W
L310	0.089	N4° 09' 59"W
L311	1.125	S10° 29' 10"E



CURVE TABLE						
CURVE #	LENGTH	RADIUS	DELTA	CHORD BEARING	CHORD LENGTH	
C8	43.03	40.00	61.63	N41° 18' 05"W	40.98	
C9	4.71	3.00	90.00	S62° 53' 00"W	4.24	
C10	1.15	160.00	0.41	N71° 33' 13"W	1.15	
C11	4.69	3.00	89.64	N26° 56' 17"W	4.23	NON-TANGENT
C12	4.67	3.00	89.28	S64° 00' 46"W	4.22	
C13	22.04	178.00	7.10	N67° 43' 23"W	22.03	
C14	4.23	3.00	80.84	N21° 02' 48"W	3.89	
C15	19.91	160.00	7.13	N57° 54' 06"W	19.90	
C16	38.49	32.00	68.92	N19° 52' 37"W	36.21	
C17	7.21	8.00	51.66	N11° 14' 46"W	6.97	
C18	15.19	12.00	72.52	N40° 25' 34"W	14.19	
C19	15.66	28.00	32.04	S20° 11' 12"E	15.45	
C20	8.64	10.00	49.52	S11° 26' 47"E	8.38	
C21	34.48	26.00	75.98	N69° 53' 30"E	32.01	
C22	43.44	140.00	17.78	S63° 13' 37"E	43.27	
C23	16.46	5.81	162.30	S29° 30' 44"W	11.48	NON-TANGENT
C24	20.03	26.00	44.14	S29° 06' 08"E	19.54	
C25	42.61	60.00	40.69	S30° 49' 49"E	41.72	

LEGEND

- SECTION LINE
- CENTERLINE
- RIGHT-OF-WAY LINE
- PROPERTY BOUNDARY
- PUBLIC UTILITY EASEMENT (PUE)
- BUILDING TIES
- PRIVATE
- LIMITED COMMON AREA
- COMMON AREA

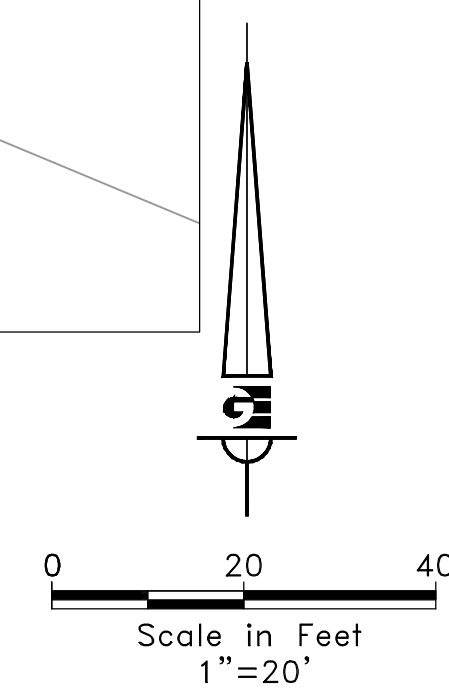

SHEET 5 OF 5

Prepared By:

CIVIL - LAND PLANNING
MUNICIPAL - LAND SURVEYING
5150 SOUTH 375 EAST OGDEN, UT
OFFICE: 801.476.0202 FAX: 801.476.0066

www.gardnerengineering.net

COUNTY RECORDER

ENTRY NO. _____ FEE PAID _____

FILED FOR RECORD AND RECORDED _____ AT _____

IN _____ BOOK OF OFFICIAL RECORDS, PAGE _____, RECORDED FOR _____

_____ COUNTY RECORDER

BY: _____ DEPUTY