

# POWDER MOUNTAIN SUNDOWN SKI JUMP

NEAR UT-158  
EDEN, UTAH 84310

## STORM WATER POLLUTION PREVENTION PLAN

*Project Number: 6416*

*Prepared For:*

**Watts Enterprises**

**Rick Everson**

5200 South Highland Drive, Ste. 101

Salt Lake City, Utah 84117

801-897-4880

rick@wattsenterprises.com

*Prepared By:*

**ENSIGN ENGINEERING**

45 West 10000 South, Suite 500

Sandy, UT 84070

(801) 255-0529



Civil Engineering  
Structural Engineering  
Land Surveying  
Urban Design  
Planning

February 26, 2015

## **Storm Water Pollution Prevention Plan**

### **for:**

Powder Mountain-Sundown Ski Jump  
Near UT-158  
Eden, Utah 84310

### **Operator(s):**

Powder Mountain Resort Management LLC  
Roger Arave  
PO Box 1119  
Eden, Utah 84310  
801-940-0665

### **SWPPP Contact(s):**

Watts Enterprises  
Rick Everson  
5200 South Highland Drive, Ste. 101  
Salt Lake City, Utah 84117  
801-897-4880  
rick@wattsenterprises.com

### **SWPPP Preparation Date:**

**02/26/2015**

*Estimated Project Dates:*

**Project Start Date: 05/01/2015**  
**Project Completion Date: 08/01/2015**

## Contents

---

<b>SECTION 1: CONTACT INFORMATION/ RESPONSIBLE PARTIES</b> .....	<b>4</b>
1.1 Owner(s), Operator, Contractors.....	4
1.2 Storm Water Team.....	6
<b>SECTION 2: SITE EVALUATION, ASSESSMENT, &amp; PLANNING</b> .....	<b>7</b>
2.1 Project/Site Information.....	7
2.2 Nature of Construction Activity.....	7
2.3 Construction Site Estimates .....	8
2.4 Soils, Slopes, Vegetation, and Current Drainage Patterns.....	8
2.5 Emergency Related Projects .....	9
2.6 Phase/Sequence of Construction Activity.....	9
2.7 Site Features and Sensitive Areas to be Protected .....	9
2.8 Maps.....	9
<b>SECTION 3: POLLUTION PREVENTION STANDARDS</b> .....	<b>10</b>
3.1 Potential Sources of Pollution.....	10
3.2 Non-Storm Water Discharges .....	11
3.3 Natural Buffers or Equivalent Sediment Controls .....	12
<b>SECTION 4: EROSION AND SEDIMENT CONTROLS</b> .....	<b>12</b>
4.1 Minimize Disturbed Area and Protect Natural Features and Soil.....	12
4.2 Establish Perimeter Controls and Sediment Barriers.....	13
4.3 Retain Sediment On-Site.....	16
4.4 Establish Stabilized Construction Exits .....	17
4.5 Protect Slopes.....	18
4.6 Stockpiled Sediment or Soil.....	19
4.7 Minimize Dust .....	19
4.8 Topsoil .....	20
4.9 Soil Compaction.....	20
4.10 High Altitude/Heavy Snows .....	20
4.11 Linear Activities.....	21
4.12 Chemical Treatment.....	21
4.13 Stabilize Soils.....	21
4.14 Final Stabilization .....	22
<b>SECTION 5: POLLUTION PREVENTION</b> .....	<b>23</b>
5.1 Spill Prevention and Response.....	23
5.2 Construction and Domestic Waste.....	24
5.3 Washing of Applicators and Containers used for Concrete, Paint or Other Materials .....	25
5.4 Establish Proper Building Material Staging Areas .....	25
5.5 Establish Proper Equipment/Vehicle Fueling and Maintenance Practices .....	25
5.6 Control Equipment/Vehicle Washing .....	25
5.7 Pesticides, Herbicides, Insecticides, Fertilizers, and Landscape Materials .....	26
5.8 Other Pollution Prevention Practices .....	26
<b>SECTION 6: INSPECTIONS &amp; CORRECTIVE ACTIONS</b> .....	<b>27</b>
6.1 Inspections .....	27
6.2 Corrective Actions .....	28

6.3	Delegation of Authority .....	28
<b>SECTION 7: TRAINING AND RECORDKEEPING .....</b>		<b>29</b>
7.1	Training.....	29
7.2	Recordkeeping .....	29
7.3	Log of Changes to the SWPPP .....	30
<b>SECTION 8: WATER QUALITY .....</b>		<b>31</b>
8.1	UIC Class 5 Injection Wells .....	31
8.2	Discharge Information .....	31
8.3	Receiving Waters .....	31
8.4	Impaired Waters.....	31
8.5	High Water Quality.....	31
8.6	Dewatering Practices .....	31
8.7	Control Storm Water Flowing onto and through the Project.....	31
8.8	Protect Storm Drain Inlets .....	35
<b>SECTION 9: POST-CONSTRUCTION BMPs .....</b>		<b>36</b>
<b>SECTION 10: CERTIFICATION.....</b>		<b>37</b>
<b>SWPPP APPENDICES .....</b>		<b>38</b>
Appendix A – General Location Map.....		38
Appendix B – Site Maps .....		38
Appendix C – Construction General Permit.....		38
Appendix D – NOI and Acknowledgement Letter from EPA/State/MS4.....		38
Appendix E – Inspection Reports .....		38
Appendix F – Corrective Action Log (or in Part 5.3).....		38
Appendix G – SWPPP Amendment Log (or in Part 7.4) .....		38
Appendix H – Subcontractor Certifications/Agreements .....		38
Appendix I – Grading and Stabilization Activities Log .....		38
Appendix J – Training Log.....		38
Appendix K – Delegation of Authority .....		38
Appendix L – Additional Information (i.e. Documentation; other permits such as dewatering, stream alteration, wetland; and out of date swppp documents) .....		38
Appendix M – BMP Specifications .....		38

## ***SECTION 1: CONTACT INFORMATION/ RESPONSIBLE PARTIES***

### ***1.1 Owner(s), Operator, Contractors***

**Owner(s):**

Summit Mountain Holding Group LLC  
Paul Strange  
3632 N. Wolf Creek Drive  
Eden, UT 84310  
415-370-1100  
paul@summit.com

**Operator(s) & Project Manager(s):**

Powder Mountain Resort Management LLC  
Roger Arave  
PO Box 1119  
Eden, Utah 84310  
801-940-0665  
Powder Mountain Resort Management LLC

**Site Supervisor(s):**

Watts Enterprises  
Kalem Minor  
5200 South Highland Drive, Ste. 101  
Salt Lake City, Utah 84117  
801-209-5883  
kalem@wattsenterprises.com

**SWPPP Contact(s):**

Watts Enterprises  
Rick Everson  
5200 South Highland Drive, Ste. 101  
Salt Lake City, Utah 84117  
801-897-4880

**This SWPPP was Prepared by:**

Ensign Engineering and Land Surveying  
Jennie Linford  
45 West Sego Lily Drive, Suite 500  
Sandy, Utah 84070  
801-255-0529  
jlinford@ensignutah.com

**Subcontractor(s): To be determined by Contractor**

Insert Company or Organization Name:  
Insert Name:  
Insert Address:  
Insert City, State, Zip Code:  
Insert Telephone Number:  
Insert Fax/Email:  
Repeat as necessary

**Emergency 24-Hour Contact:**

State of Utah  
Department of Environmental Quality  
Division of Water Quality  
288 North 1450 West  
P.O. Box 144870  
Salt Lake City, Utah 84114  
801-538-6951

Weber County Engineering Office-Weber Center  
2380 Washington Blvd Ste 240  
Ogden, Utah 84401  
801-399-8374

Environmental Protection Agency  
Denver, Colorado  
800-759-4372

## ***1.2 Storm Water Team***

### **SWPPP Preparation:**

Ensign Engineering  
Jennie Linfoord  
45 West 1000 South, Ste 500  
Sandy, Utah 84070  
801-255-0529  
jlinford@ensignutah.com

### **SWPPP Maintenance and Application:**

Watts Enterprises  
Kalem Minor  
5200 South Highland Drive, Ste. 101  
Salt Lake City, Utah 84117  
801-209-5883

Powder Mountain Resort Management LLC  
Roger Arave  
PO Box 1119  
Eden, Utah 84310  
801-940-0665

Subcontractor(s): To be determined by Contractor

Insert Company or Organization Name:

Insert Name:

Insert Address:

Insert City, State, Zip Code:

Insert Telephone Number:

Insert Fax/Email:

## ***SECTION 2: SITE EVALUATION, ASSESSMENT, & PLANNING***

### ***2.1 Project/Site Information***

Project/Site Name: Powder Mountain-Sundown Ski Jump

Project Street/Location: Near UT-158

City: Eden State: Utah ZIP Code: 84310

County or Similar Subdivision: Weber County

Latitude/Longitude (Use **one** of three possible formats, and specify method)

Latitude: 41.3759 ° N (decimal) Longitude: -111.7876 ° W (decimal)

Method for determining latitude/longitude:

USGS topographic map (specify scale: \_\_\_\_\_)  EPA Web site  GPS

Other (please specify): Google Earth

Is the project located in Indian country?  Yes  No

If yes, name of Reservation, or if not part of a Reservation, indicate "not applicable." \_\_\_\_\_

Is this project considered a federal facility?  Yes  No

UPDES project or permit tracking number\*: \_\_\_\_\_

*\*(This is the unique identifying number assigned to your project by your permitting authority after you have applied for coverage under the appropriate National Pollutant Discharge Elimination System (UPDES) construction general permit.)*

### ***2.2 Nature of Construction Activity***

Describe the general scope of the work for the project, major phases of construction, etc:

Description of Project: This purpose of this project is to construct a ski jump in Powder Mountain Ski Resort.

Nature of Work: Construction of the finished site will include the following earth-disturbing activities: mass grading.

Phasing of Construction: This project will be completed in one phase.

What is the function of the construction activity?

Residential  Commercial  Industrial  Road Construction  Linear Utility

Other (please specify):



Estimated Project Start Date: 05/01/2015  
Estimated Project Completion Date: 08/01/2015

### **2.3 Construction Site Estimates**

The following are estimates of the construction site.

Total project area:	0.9 acres
Construction site area to be disturbed:	0.9 acres
Percentage impervious area before construction:	0%
Runoff coefficient before construction:	0.6
Percentage impervious area after construction:	0%
Runoff coefficient after construction	0.6

### **2.4 Soils, Slopes, Vegetation, and Current Drainage Patterns**

Soil type(s): 4-6 inches of topsoil overlying silt and sandy clay.

Slopes (describe current slopes and note any changes due to grading or fill activities): The existing site has an average downward slope from west to east of 31%. The proposed grading plan indicates that the natural grade will not be changed by mass grading for the first 243 ft of the ski jump. The desired grade for the jump will be accomplished by snow grading, with the desired slope being -36.40%. Mass grading and fill will then be used on the next 66 ft to create a slope of 0.00%. The next 157 ft will then be graded to a slope of -75.36%, with the last 98.4 ft will be graded to a slope of 0.00%. All of these distances and slopes can be found on the Site and Grading Plan.

Drainage Patterns (describe current drainage patterns and note any changes dues to grading or fill activities): There is no storm drain system on this site, nor is there any proposed. Storm water simply falls onto the ground and percolates on site or runs off into the surrounding mountain area.

Vegetation: The site's current conditions contain natural grasses, weeds, and trees. Per the Erosion Control Plan, there is an area where all vegetation will have to be cut down to 12" from ground surface, however, no soil will be disturbed in this area.

## ***2.5 Emergency Related Projects***

Emergency-Related Project?       Yes       No

## ***2.6 Phase/Sequence of Construction Activity***

The project has been planned to occur in one phase. During construction, areas of the site not being directly impacted by work shall remain with existing vegetative cover. This project is comprised completely by mass grading, and thus will be the only earth disturbing activity taking place in this phase.

Sequencing: Sediment ponds and traps, vegetated buffer strips, sediment barriers or filters, dikes, and other BMP's intended to trap sediment on site will be installed before other land-disturbing activities take place (see SWPPP Sequencing Diagram). Silt fences and temporary drainage swales shall be placed per the Erosion and Sediment Control Plan, and elsewhere as appropriate. These BMP's shall be maintained until stabilization of disturbed areas is complete. The measures shown on the Erosion and Sediment Control Plan are not exclusive, and cannot all be applied simultaneously. It is the responsibility of the contractor to employ the correct best management practices for each construction stage, and to maintain the BMP's for as long as they are appropriate.

## ***2.7 Site Features and Sensitive Areas to be Protected***

There are located on site several native trees that will have to be cut down for this project. Also, there are areas where the topsoil will be stripped as shown on the Erosion Control Plan. Any topsoil that is removed will be restored after completion of grading. Also, the disturbed area will be re-vegetated with a seed mix and applied with a spraymatt bonded fiber matrix. The details for the re-vegetation are listed on the Erosion Control Plan.

## ***2.8 Maps***

The following site maps are included in Appendix A: Site and Grading Plan, Erosion Control Plan

## **SECTION 3: POLLUTION PREVENTION STANDARDS**

### **3.1 Potential Sources of Pollution**

<b>Activities</b>	<b>Check with an X the activities that apply</b>	Sediment	Nutrients	Heavy Metals	pH (acids and bases)	Pesticides & Herbicides	Oil & Grease	Bacteria & Viruses	Trash, Debris, Solids	Other Pollutants
Clearing, grading, excavating, and un-stabilized areas	X	√							√	
Paving operations		√					√		√	
Concrete washout, stucco and cement waste				√	√				√	
Structure construction, painting, cleaning				√	√				√	√
Demolition and debris disposal		√							√	
Dewatering operations		√							√	
Waterline flushing		√	√		√				√	√
Material Delivery and storage	X	√	√	√	√		√		√	√
Material use during building process			√	√	√		√		√	√
Solid waste disposal	X								√	√
Hazardous Waste, contaminated spills				√	√	√	√			√
Spills	X			√	√	√	√			√
Sanitary waste	X		√		√			√		
Vehicle/equipment fueling, maintenance, use and storage	X						√		√	√
Landscaping operations	X	√	√						√	√

**General Materials Handling Practices:** Hazardous materials shall be handled in accordance with all applicable laws. Hazardous materials shall be kept offsite, or shall be kept in an impervious contained area and covered as appropriate so that spills will not run off or seep into the ground. Potential pollutants will be stored and used in a manner consistent with the manufacturer's instructions in a secure location. To the extent practicable, material storage areas should not be located near storm drain inlets and should be equipped with covers, roofs, or secondary containment as needed to prevent storm water from contacting stored materials. Chemicals that are not compatible (such as sodium bicarbonate and hydrochloric acid) shall be stored in segregated areas so that spilled materials cannot combine and react. Materials disposal will be in accordance with the manufacturer's instructions and applicable local, state, and federal regulations. Materials no longer required for construction will be removed from the site as soon as practicable.

**Sanitary Waste:** Portable sanitary facilities shall be maintained during subdivision construction and all waste disposed of in accordance with all applicable laws. Portable toilets shall be surrounded in a berm sufficient to contain any spills and far enough from toilet as to avoid being damaged if the toilet topples.

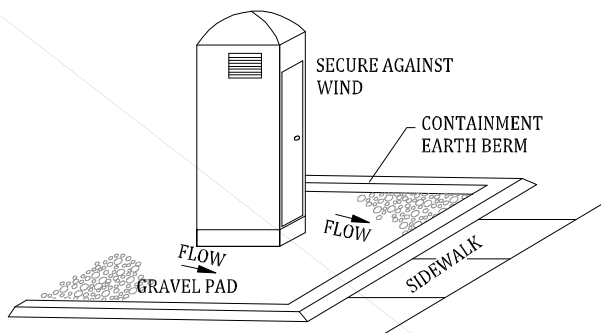

**PORTABLE TOILET**  
SCALE: NONE

**Construction Debris, Trash, and Garbage:** Waste disposal container(s) shall be kept on site as needed to keep the site clear of obstruction and BMP's clear and functional. Containers shall be kept covered and emptied weekly, or more frequently as needed. Litter, construction debris, and construction chemicals exposed to storm water shall be picked up prior to anticipated storm events or otherwise prevented from becoming a pollutant source for storm water discharges.

### 3.2 Non-Storm Water Discharges

**Potential Non-Sediment Pollutants and Sources to Stormwater Runoff:** non-sediment pollutants that may be present during construction activities include:

1. petroleum products including fuel, lubricants, hydraulic fluids, and form oils
2. polymer used for soil stabilization

3. water treatment chemicals (coagulant, acid, sodium bicarbonate)
4. fertilizers
5. trash & litter
6. sanitary waste

These materials, and other materials used during construction with the potential to impact storm water, will be stored, managed, used, and disposed of in a manner that minimizes the potential for releases to the environment and especially into storm water.

PH-modifying sources will be managed to prevent contamination of runoff and storm water collected on site. The most common sources of ph-modifying materials are bulk cement, cement kiln dust (ckd), fly ash, new concrete washing and curing waters, waste streams generated from concrete grinding and sawing, exposed aggregate processes, and concrete pumping and mixer washout waters. As this project will not involve the use of concrete, it is not anticipated that this will be a concern.

#### ***Allowable Non-Stormwater Discharge Management***

Non-stormwater discharges include dust control water, vehicle washwater, waterline flushings, landscape irrigation, and other non-polluted water sources. It is anticipated that these water sources will be effectively treated by the BMP's installed to control storm water. For trench dewatering and other activities with high volume of unpolluted water, where there is a potential of overloading storm water sediment controls, the discharge shall be piped to the nearest storm drain inlet and discharge directly into the storm drain, bypassing the sediment controls.

### ***3.3 Natural Buffers or Equivalent Sediment Controls***

#### **Buffer Compliance Alternatives**

Are there any surface waters within 50 feet of your project's earth disturbances?  YES  NO

## ***SECTION 4: EROSION AND SEDIMENT CONTROLS***

### ***4.1 Minimize Disturbed Area and Protect Natural Features and Soil***

This section includes information regarding erosion and sediment control Best Management Practices (BMP's) including details, procedures, and protocols to be followed in implementing the BMP's. All temporary and permanent erosion and sediment control BMP's shall be maintained and repaired as needed to assure continued performance of their intended function. All maintenance and repair will be conducted in accordance with BMP's. The project is subject to inspection by city, county, state, and federal officials at any time to verify compliance with this SWPPP and with applicable ordinances. See SWPPP implementation sequence on the Erosion and Sediment Control Plan for sequence of BMP implementation. The measures shown herein and on the Erosion and Sediment Control Plan are not exclusive, and cannot all be applied simultaneously. ***It is the responsibility of the contractor to employ the correct best***

*management practices for each stage of construction, and to maintain the BMP's for as long as they are appropriate.*

#### 4.2 Establish Perimeter Controls and Sediment Barriers

Temporary Measures: Drainage swales, silt fences, and temporary culverts will channel all runoff contaminated with sediment or otherwise affected by construction activities into temporary sedimentation basins. Storm events of higher intensity and/or longer duration will not be completely retained, but the sedimentation basins will provide an opportunity for sedimentation before the water leaves the site. All ditches and other water conveyances draining active construction areas to the sedimentation basins will be stabilized with rock, matting, or other stabilizing method with check dams or sediment traps placed as needed to reduce water velocities and settle out as much sediment as possible prior to entering the temporary sedimentation ponds. Sediment must be removed from sedimentation ponds and sediment traps when design capacity has been reduced by 50%.

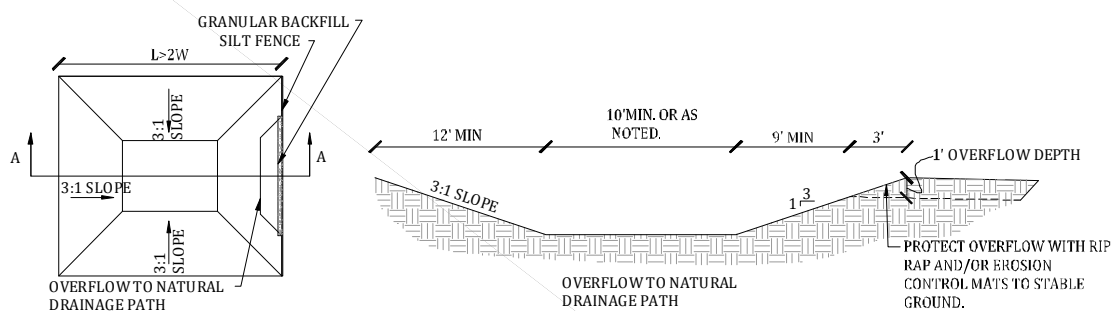

**PLAN VIEW**

**A-A SECTION**

**NOTES:**

1. CLEAN OUT BASIN WHEN CAPACITY IS REDUCED BY HALF.
2. SIZE BASIN PER MINIMUM DIMENSIONS SHOWN, AND PER DIMENSIONS IN PLAN, WHICHEVER IS GREATER.
3. SAFETY FENCING IS REQUIRED FOR DEPTH GREATER THAN THREE FEET.
4. WHERE 2:1 RATIO OF LENGTH TO WIDTH IS NOT AVAILABLE, CONSTRUCT BERM(S) FOR BAFFLE(S) BETWEEN INLET AND OUTLET TO ACHIEVE 2:1 FLOW LENGTH RATIO.
5. WHERE TEMPORARY SEDIMENTATION WILL BE CONVERTED TO A PERMANENT DETENTION POND, PROTECT OUTLET PER DT.L. L, TEMPORARY BASIN OUTLET PROTECTION.



**TEMPORARY SEDIMENTATION BASIN**

SCALE: NONE

Drainage Swale: Drainage swales shall be used to capture contaminated runoff before exiting the site, to capture wash water, and other sediment laden storm flows and convey the flow to sedimentation basins for treatment. Stabilization of the swale with rip rap, erosion control mats, check dams, and/or sediment traps is required per the following details.

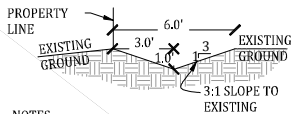

- NOTES:**
1. PROTECT CHANNEL FROM EROSION AS NECESSARY WITH RIP RAP, EROSION CONTROL MATS AND/OR ROCK CHECK DAMS
  2. SEDIMENT TRAPS REQUIRED AT 200' SPACING OR AS SHOWN ON PLANS, WHICHEVER IS MORE STRINGENT.
  3. FOR SWALES STEEPER THAN 5%, STABILIZE SWALES WITH RIP RAP LINING IN SWALE AND ROCK CHECK DAMS SPACED AT EVERY THREE FEET OF DROP IN FLOWLINE.

**C**  
**--- DRAINAGE SWALE**  
 SCALE: NONE

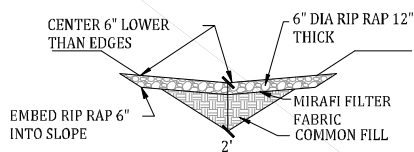

**A-A' SECTION**

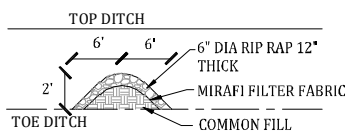

**B-B' SECTION**

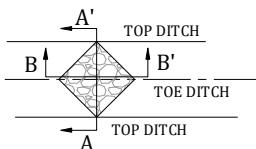

**PLAN VIEW**

- NOTES:**
1. PLACE CHECK DAMS PERPENDICULAR TO FLOW DIRECTION
  2. DO NOT PLACE DAMS ACROSS NATURAL STREAM BEDS
  3. CONSTRUCT CHECK DAMS SO THAT WATER DOES NOT FLOW AROUND THE ENDS OF THE DAM.
  4. REMOVE ACCUMULATED SEDIMENT WHEN DEPTH REACHES 1 FOOT.

**F**  
**--- ROCK CHECK DAM**  
 SCALE: NONE

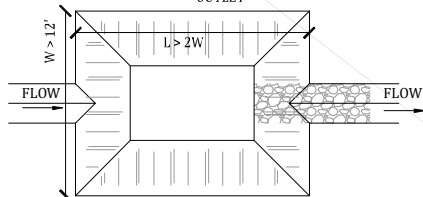
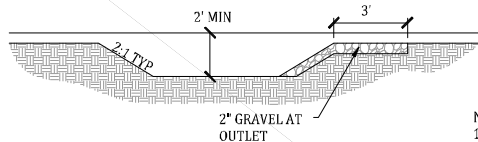

**PLAN VIEW**

- NOTES:**
1. PLACE SEDIMENT TRAPS AT LOCATIONS SHOWN ON PLANS, AND WHEREVER APPROPRIATE TO INTERCEPT SEDIMENT LADEN FLOW ON SITE.
  2. MAINTAIN PROPER FUNCTION OF SEDIMENT TRAP UNTIL DISTURBED AREAS CONTRIBUTING TO BASIN HAVE BEEN PAVED OR REVEGETATED.
  3. REMOVE ACCUMULATED SEDIMENT WHEN CAPACITY IS DECREASED BY HALF.

**H**  
**--- SEDIMENT TRAP**  
 SCALE: NONE

**Temporary Silt Fence:** Temporary Silt Fence shall be installed at the downhill edge of disturbed areas, where drainage swales are not present, to prevent sediment-laden water from exiting the disturbed area and contaminating neighboring undisturbed ground or running off into the storm

water system. Silt fence shall be installed parallel to contours for slopes steeper than 5%, such that the line of silt fence downhill overlaps the line of the silt fence by a minimum of five feet.

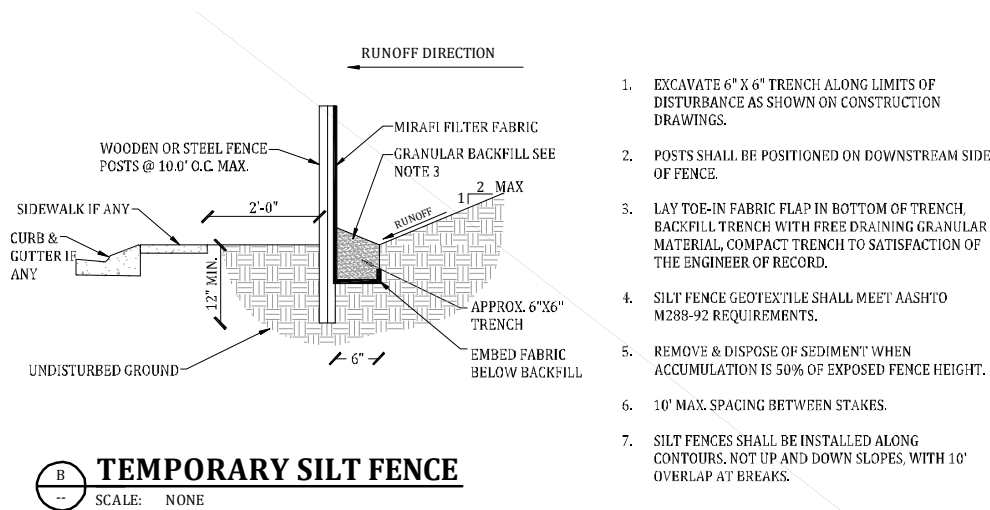

**Filter Strip:** Temporary sedimentation pond overflows shall discharge across erosion control mat or rip rap, and permanent detention basins shall discharge across rip rap, allowing sediment and other contaminants to be intercepted before reaching receiving waters, and to protect discharge from erosion.

**Outlet Protection:** Adequate energy dissipation, erosion control, and soil stabilization measures (e.g., rock or other energy dissipation techniques) will be provided for all point source discharges of storm water, including run-on discharges and outlets from onsite discharges.

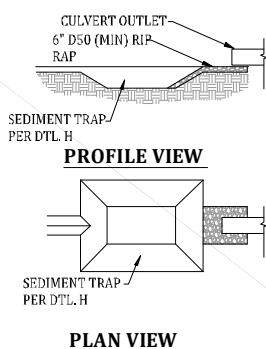

**0** **OUTLET PROTECTION**  
 -- SCALE: NONE

**Permanent Storm Drain System:** Once the storm drain improvements are in place water will be channeled to a permanent detention basin. The outlet from the detention basin shall be protected per project details to cause pond to function as a sedimentation basin until land is stabilized. Permanent drainage swales may also be used to capture contaminated runoff, and shall be protected and maintained.



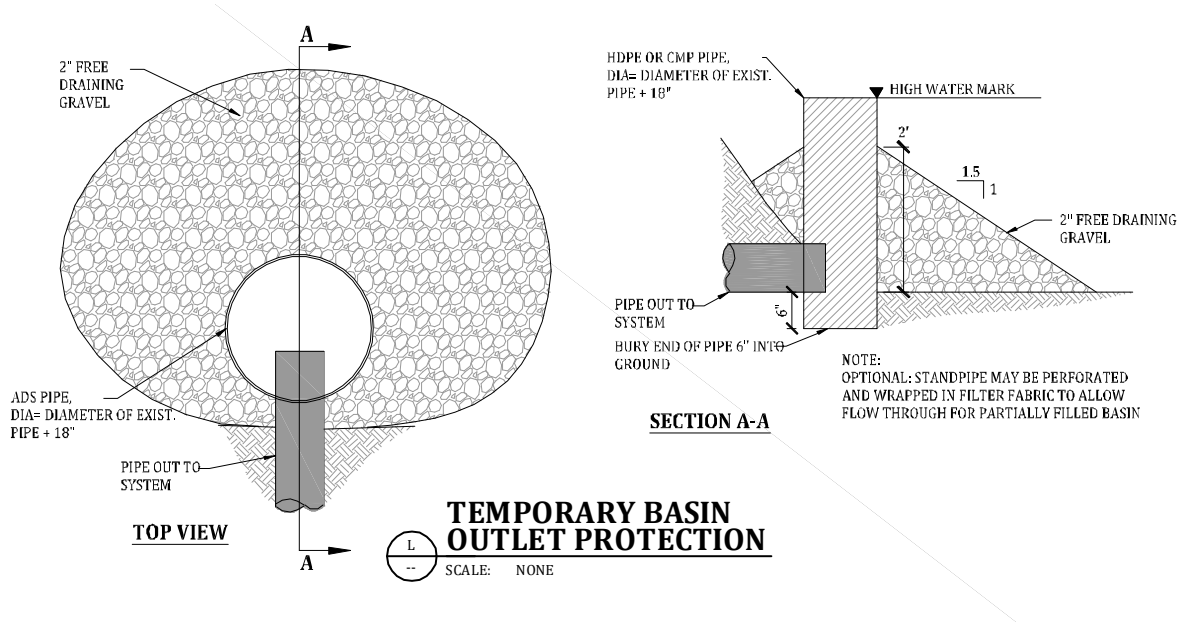

### 4.3 Retain Sediment On-Site

**Sedimentation Basins:** Temporary sedimentation basins shall be used to retain sediment onsite. Temporary basins are sized to completely retain a 2-year 24-hour storm based on the tributary area, all pervious. Storm events of higher intensity and/or longer duration will not be completely retained, but the sedimentation basins will provide an opportunity for sedimentation before the water leaves the site. Once graded, the permanent detention basin will serve as the sedimentation basin. Sediment must be removed from sedimentation ponds when design capacity has been reduced by 50%.

**Temporary Silt Fence:** Temporary Silt Fence shall be installed at the downhill edge of disturbed areas, where drainage swales are not present, to prevent sediment-laden water from exiting the disturbed area and contaminating neighboring undisturbed ground or running off into the storm water system. Silt fence shall be installed parallel to contours for slopes steeper than 5%, such that the line of silt fence downhill overlaps the line of the silt fence by a minimum of five feet.

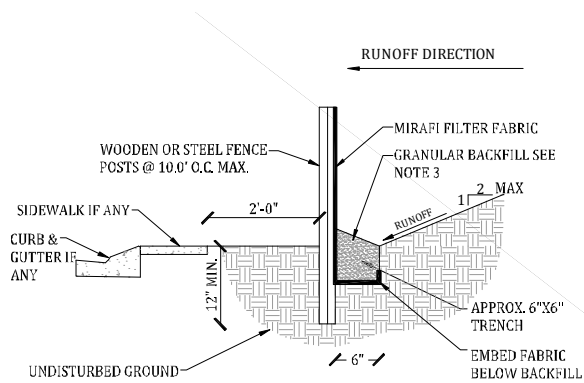

1. EXCAVATE 6" X 6" TRENCH ALONG LIMITS OF DISTURBANCE AS SHOWN ON CONSTRUCTION DRAWINGS.
2. POSTS SHALL BE POSITIONED ON DOWNSTREAM SIDE OF FENCE.
3. LAY TOE-IN FABRIC FLAP IN BOTTOM OF TRENCH, BACKFILL TRENCH WITH FREE DRAINING GRANULAR MATERIAL, COMPACT TRENCH TO SATISFACTION OF THE ENGINEER OF RECORD.
4. SILT FENCE GEOTEXTILE SHALL MEET AASHTO M288-92 REQUIREMENTS.
5. REMOVE & DISPOSE OF SEDIMENT WHEN ACCUMULATION IS 50% OF EXPOSED FENCE HEIGHT.
6. 10' MAX. SPACING BETWEEN STAKES.
7. SILT FENCES SHALL BE INSTALLED ALONG CONTOURS, NOT UP AND DOWN SLOPES, WITH 10' OVERLAP AT BREAKS.

**B** **TEMPORARY SILT FENCE**  
 SCALE: NONE

#### 4.4 Establish Stabilized Construction Exits

**Stabilized Construction Entrance:** See Erosion and Sediment Control Plan for anticipated construction entrance location. Contractor may field adjust as necessary and record location on drawings. All construction vehicles exiting the site will be limited to this access. The access will be stabilized with quarry spalls, crushed rock, or asphalt to prevent tracking sediment onto paved areas.

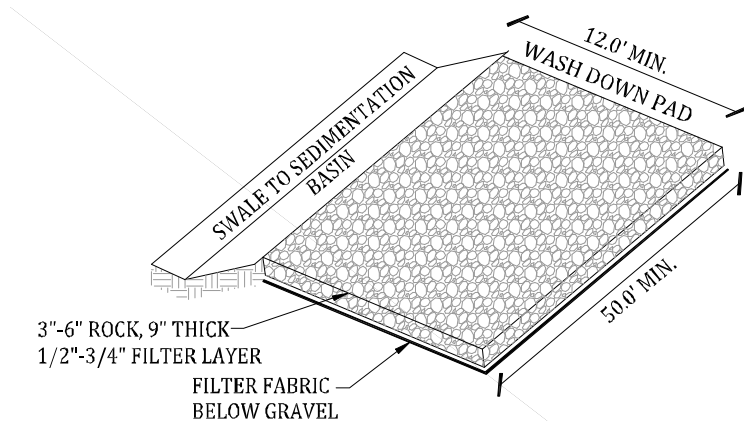

NOTE: PLACE SIGN ADJACENT TO ENTRANCE " CONSTRUCTION TRAFFIC ONLY - ALL CONSTRUCTION TRAFFIC SHALL ENTER AND EXIT SITE AT THIS LOCATION"

### **TEMPORARY VEHICLE WASHDOWN & STABILIZED CONSTRUCTION ENTRANCE**

**D** **TEMPORARY VEHICLE WASHDOWN & STABILIZED CONSTRUCTION ENTRANCE**  
 SCALE: NONE

## 4.5 Protect Slopes

**General Practices:** Cut and fill slopes on this project have been designed and will be constructed so as to minimize erosion. Soil types have been analyzed and considered for their potential to erode. Slope runoff velocities shall be reduced by terracing, creating diversions, and surface contouring. Uncontaminated run-on water from off-site will be intercepted at the top of the slope and diverted around the active construction area. Down slope flows will be contained in pipes, slope drains, and/or stabilized channels.

**Temporary Slope Drains:** Concentrated flows at tops of slopes shall be conveyed to the bottom of the slope via temporary slope drains, comprised of bermed inlets, flexible piping, and stabilized outlets. In some cases unstable slopes will be temporarily covered with plastic to prevent erosion and to protect water quality. When soil is disturbed downstream of the slope, the slope drainage must be conveyed around the disturbed soil to prevent erosion by piping it directly to the nearest drain or stabilized area.

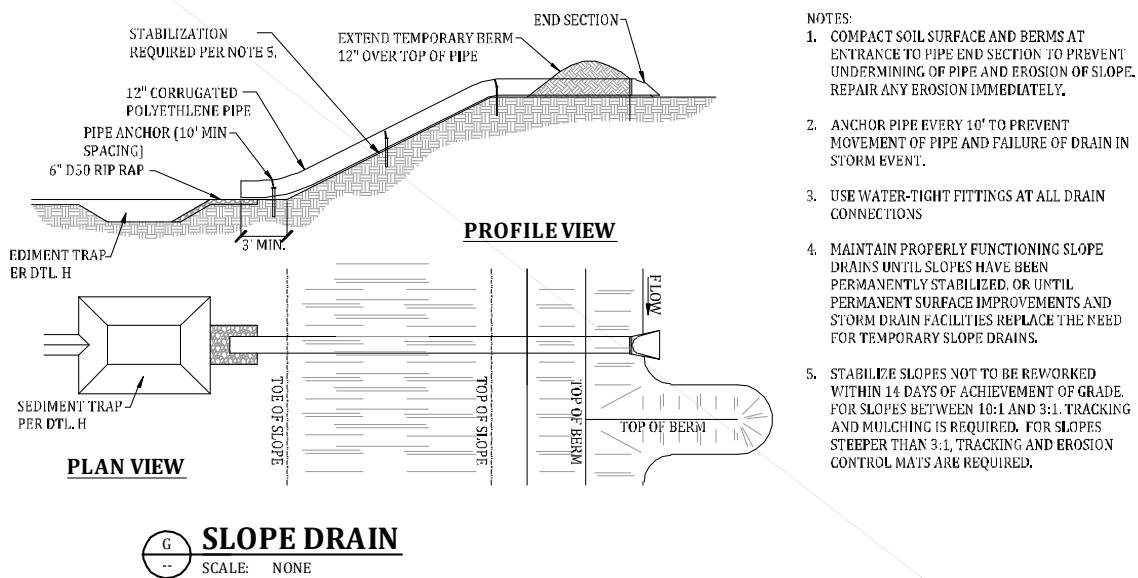

**Straw Wattles:** For disturbed slopes without concentrated flow, straw wattles shall be placed along contours, such that ends of wattles overlap with ends of wattles uphill and down, to stabilize the slope while vegetation is established.

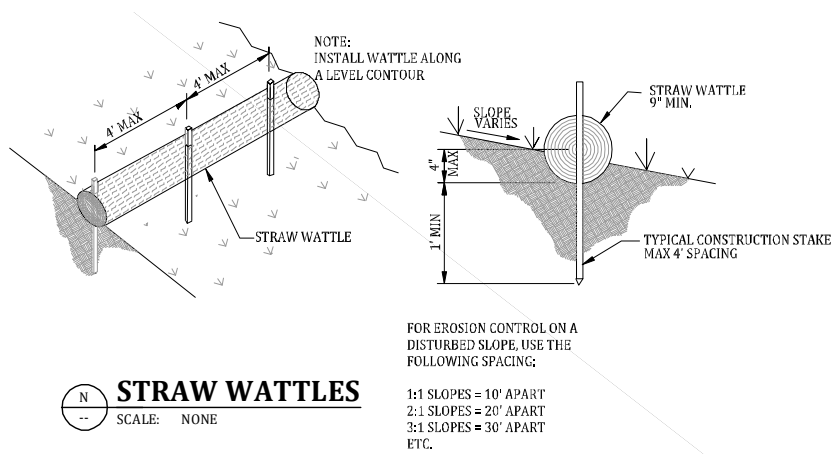

#### 4.6 Stockpiled Sediment or Soil

**Soil Covering:** All slopes as well as drainage ditches, swales, and exposed flat surfaces as deemed necessary by the erosion and sediment control lead shall be covered prior to the onset of the rainy season or any anticipated storm event. The primary stabilization method used will be covering soils with an approved matting and/or hydroseeding. Areas of the project, which have not been properly stabilized by vegetation by the onset of the wet season, will be covered with transparent plastic sheeting before any anticipated storm event to prevent sediment transport. Plastic sheeting will also be used as an emergency BMP to cover previously stabilized areas, which begin to erode. Loose straw and mulch covers are not to be used as they may be washed into drainage structures.

**Stockpile Covering:** All temporary soil stockpiles will be bermed around or covered with plastic prior to anticipated rainfall events. Long-term stockpiles will be compacted and hydroseeded prior to the onset of wet weather.

#### 4.7 Minimize Dust

**Dust Control:** Soils, gravels, etc., whether stockpiled or placed, shall be kept covered and/or adequately moist to prevent airborne dust from leaving the site.

**Vehicle Wash-Down:** A temporary truck wheel wash station shall be constructed to ensure control of sediment at the construction exit point. The wash system shall be constructed on the site at a location just prior to where trucks leave the site access and enter the street. The system shall consist of a cobble pad lined below with filter fabric, and an adjacent drainage swale and sedimentation basin to collect wash water for settlement of debris. Wash water may be reused after settling, infiltrated onsite, or transported off-site for disposal. Accumulated sediments may be reused onsite or disposed of off-site. Wheel wash station may be combined with the stabilized construction entrance, provided that the owner/operator ensures that it effectively serves both purposes.

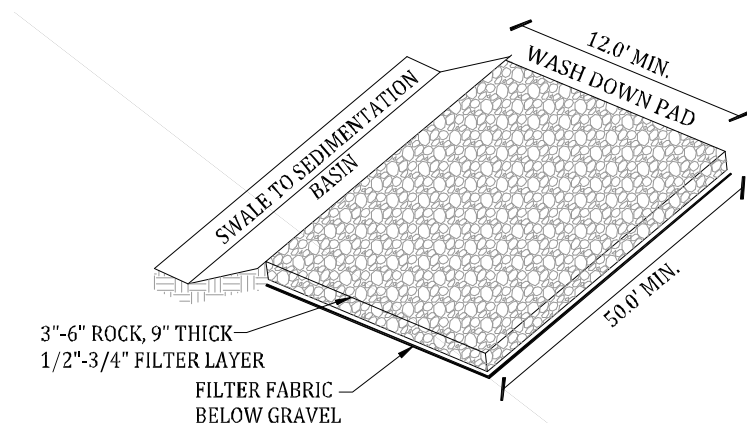

NOTE: PLACE SIGN ADJACENT TO ENTRANCE " CONSTRUCTION TRAFFIC ONLY - ALL CONSTRUCTION TRAFFIC SHALL ENTER AND EXIT SITE AT THIS LOCATION"

## **TEMPORARY VEHICLE WASHDOWN & STABILIZED CONSTRUCTION ENTRANCE**



SCALE: NONE

### **4.8 Topsoil**

Topsoil Conservation: Existing topsoil shall be harvested when an area is to be disturbed, and stockpiled on site. Topsoil shall then be spread when finish grade is achieved in order to encourage revegetation. As an alternative to storing stockpiled soil, new topsoil may be imported post-construction, provided all unpaved areas not otherwise landscaped are treated for revegetation.

### **4.9 Soil Compaction**

Limit of Disturbance: A temporary silt fence shall be installed to indicate the area of disturbance of the project to ensure that vehicle access is limited to this area.

Revegetation: All remaining disturbed land shall be reseeded with native grass mixture and protected until grasses are established.

Removal of Temporary BMP's: All temporary erosion and sediment control BMP's will be removed within 30 days after final site stabilization is achieved or after the temporary BMP's are no longer needed. Trapped sediment will be removed or stabilized on site. Disturbed soil areas resulting from removal of BMP's or vegetation will be permanently stabilized as soon as possible.

### **4.10 High Altitude/Heavy Snows**

Project will be completed before heavy snows will interfere with construction.

#### 4.11 Linear Activities

Not applicable to project.

#### 4.12 Chemical Treatment

There will be no chemical treatments on this project.

#### 4.13 Stabilize Soils

Dust Control: Soils, gravels, etc., whether stockpiled or placed, shall be kept covered and/or adequately moist to prevent airborne dust from leaving the site.

Mulching And Erosion Control Mats: Once disturbed land has been worked to finish grade, or is to be left unworked for more than 14 calendar days, the land shall be stabilized by one of the following methods, to be determined at a minimum by the grade constraints listed. The owner/operator may to apply a more stringent protection than required by the grade, as appropriate to the needs of the site:

1. grade less than 10%: tracking - lines of tracks perpendicular to flow direction
2. grade between 10% and 3:1 (33%) - tracking and mulching - straw, hydroseed, or other
3. grade steeper than 3:1 (33%) - erosion control mats

For locations where soil and/or slope conditions will make it difficult for vegetation to reestablish within six months, a bonded fiber matrix shall be employed to seed and stabilize disturbed land.

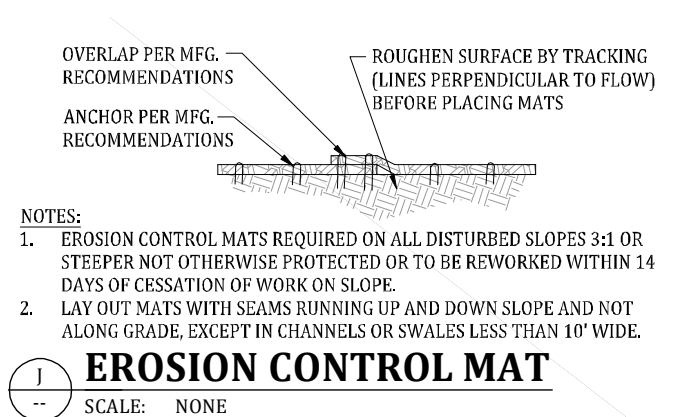

Temporary Native Seeding: Native seeds shall be used where necessary.

Permanent Native Seeding: Plant disturbed slopes with native grass mixture upon completion of grading activities and provide temporary irrigation till established.

Permanent Landscaping: Plant disturbed slopes with native grass mixture upon completion of grading activities and provide temporary irrigation till established.

Maintenance Of Existing Vegetation: Existing and new vegetation will be maintained to the maximum extent practicable to prevent the contamination of storm water with sediment. Vegetated areas beginning to show signs of erosion or soil transport shall be repaired and stabilized through mulching, erosion control mats, or other methods as necessary

Soil Covering: All slopes as well as drainage ditches, swales, and exposed flat surfaces as deemed necessary by the erosion and sediment control lead shall be covered prior to the onset of the rainy season or any anticipated storm event. The primary stabilization method used will be covering soils with an approved matting and/or hydroseeding. Areas of the project, which have not been properly stabilized by vegetation by the onset of the wet season, will be covered with transparent plastic sheeting before any anticipated storm event to prevent sediment transport. Plastic sheeting will also be used as an emergency BMP to cover previously stabilized areas, which begin to erode. Loose straw and mulch covers are not to be used as they may be washed into drainage structures.

Stockpile Covering: All temporary soil stockpiles will be bermed around or covered with plastic prior to anticipated rainfall events. Long-term stockpiles will be compacted and hydroseeded prior to the onset of wet weather.

#### ***4.14 Final Stabilization***

After construction has been completed and landscaping installed per the Landscape Plan, the following steps shall be taken to close out the project:

Revegetation: All remaining disturbed land shall be reseeded with native grass mixture and protected until grasses are established.

Removal of Temporary BMP's: All temporary erosion and sediment control BMP's will be removed within 30 days after final site stabilization is achieved or after the temporary BMP's are no longer needed. Trapped sediment will be removed or stabilized on site. Disturbed soil areas resulting from removal of BMP's or vegetation will be permanently stabilized as soon as possible.

Cleanup: All inlets and junctions shall be cleaned. All waste materials shall be removed and properly disposed of.

Notice of Termination (N.O.T.): After completion of the office and parking construction and cleanup, the owner shall file a N.O.T. with the state DEQ Division of Water Quality to certify that construction activities have been completed and the site properly cleaned up and commissioned.

Subsequent Construction Projects: future phases and adjacent projects are not covered by this SWPPP and shall be handled separately.

Transfer of Ownership/Responsibility: After initial revegetation and stabilization, and transfer of ownership to city of public right of way and public parcels including detention basins, it will be the responsibility of the city to maintain the public right of way and detention basin BMP's

including but not limited to the storm drainage system, detention basin, and rip rap. It will be the responsibility of the owner to maintain landscaping in common spaces. It will be the responsibility of the owner to maintain private property in compliance with all applicable laws and ordinances.

## ***SECTION 5: POLLUTION PREVENTION***

### ***5.1 Spill Prevention and Response***

Spill Kits And Training: Spill kits containing materials and equipment for spill response and cleanup will be maintained at the site. Suggested spill kit may contain:

- oil absorbent pads (one bale),
- oil absorbent booms (40 feet),
- 55 gallon drums (2),
- 9 mil plastic bags (10),
- personal protective equipment including gloves and goggles.

Facility personnel with primary responsibility for spill response and cleanup will receive training from the site superintendent. This training will include identifying the location of spill kits and other spill response equipment and the use of spill response materials.

Spill response equipment will be inspected and maintained as necessary to replace any materials used in spill response activities.

Hazardous Material Spills: In the event of a spill, work shall be stopped and best efforts made to contain the spill. The site superintendent shall be notified immediately, and will assess the situation and determine the appropriate response. If oil sheen is observed on surface water (e.g., settling ponds, detention pond, swales), absorbent pads and/or booms will be applied to contain and remove the oil. The source of the oil sheen will also be identified and removed or repaired as necessary to prevent further releases.

Any discharges in 24 hours equal to or in excess of the reportable quantities listed in 40 CFR 117, 40 CFR 110, and 40 CFR 302 will be reported to the National Response Center and the Division of Water Quality (DWQ) as soon as practical after knowledge of the spill is known to the permittees. The permittee shall submit within 14 calendar days of knowledge of the release a written description of: the release (including the type and estimate of the amount of material released), the date that such release occurred, the circumstances leading to the release, and measures taken and/or planned to be taken to the Division of Water Quality (DWQ), 288 North 1460 West, P.O. Box 144870, Salt Lake City, Utah 84114-4870. The Storm Water Pollution Prevention Plan must be modified within 14 calendar days of knowledge of the release to provide



a description of the release, the circumstances leading to the release, and the date of the release. In addition, the plan must be reviewed to identify measures to prevent the reoccurrence of such releases and to respond to such releases, and the plan must be modified where appropriate.

Agency	Phone Number
National Response Center	(800) 424-8802
Division of Water Quality ( DWQ) 24-Hr Reporting	(801) 538-6146 (801) 536-4123
Utah Department of Health Emergency Response	(801) 580-6681

Material	Media Released To	Reportable Quantity
Engine oil, fuel, hydraulic & brake fluid	Land	25 gallons
Paints, solvents, thinners	Land	100 lbs (13 gallons)
Engine oil, fuel, hydraulic & brake fluid	Water	Visible Sheen
Antifreeze, battery acid, gasoline, engine degreasers	Air, Land, Water	100 lbs (13 gallons)
Refrigerant	Air	1 lb

## 5.2 Construction and Domestic Waste

Sanitary Waste: Portable sanitary facilities shall be maintained during subdivision construction and all waste disposed of in accordance with all applicable laws. Portable toilets shall be surrounded in a berm sufficient to contain any spills and far enough from toilet as to avoid being damaged if the toilet topples.

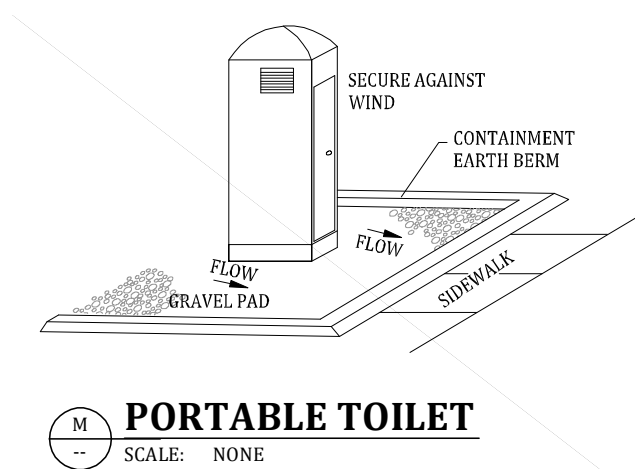

**Construction Debris, Trash, and Garbage:** Waste disposal container(s) shall be kept on site as needed to keep the site clear of obstruction and BMP's clear and functional. Containers shall be kept covered and emptied weekly, or more frequently as needed. Litter, construction debris, and construction chemicals exposed to storm water shall be picked up prior to anticipated storm events or otherwise prevented from becoming a pollutant source for storm water discharges.

### ***5.3 Washing of Applicators and Containers used for Concrete, Paint or Other Materials***

This project only includes mass grading, and therefore, no concrete, paint, or other such materials will be used.

### ***5.4 Establish Proper Building Material Staging Areas***

**Materials Staging Area:** See the Erosion and Sediment Control Plan for the designated materials stockpile and staging area. Inert materials that are stockpiled that pose a potential for causing pollution of storm water include gravels and soil materials. The contractor shall construct a berm or swale around the downhill side of the staging area as practical to contain any potentially polluted runoff and channel it to the sedimentation basin. Non-sediment pollutants including PH-modifying sources of pollutants shall be stored in a lined bermed area of sufficient capacity to contain all of the anticipated storm water and pollutant in the event of a leak or spill.

### ***5.5 Establish Proper Equipment/Vehicle Fueling and Maintenance Practices***

**Vehicles And Equipment:** Fix leaks of fuel, oil, etc. immediately. Perform refueling and servicing off site whenever possible. For on-site service or refueling, provide an impervious contained area such that spills will not run off to the storm drainage system or seep into the ground. Conduct maintenance under cover during wet weather if possible. Materials spilled during maintenance operations will be cleaned up immediately and properly disposed of.

### ***5.6 Control Equipment/Vehicle Washing***

**Vehicle Wash-Down:** A temporary truck wheel wash station shall be constructed to ensure control of sediment at the construction exit point. The wash system shall be constructed on the site at a location just prior to where trucks leave the site access and enter the street. The system shall consist of a cobble pad lined below with filter fabric, and an adjacent drainage swale and sedimentation basin to collect wash water for settlement of debris. Wash water may be reused after settling, infiltrated onsite, or transported off-site for disposal. Accumulated sediments may be reused onsite or disposed of off-site. Wheel wash station may be combined with the stabilized construction entrance, provided that the owner/operator ensures that it effectively serves both purposes.

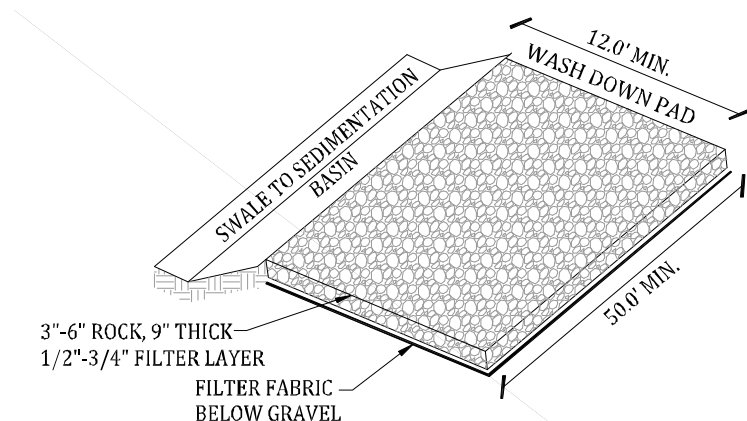

NOTE: PLACE SIGN ADJACENT TO ENTRANCE " CONSTRUCTION TRAFFIC ONLY -  
ALL CONSTRUCTION TRAFFIC SHALL ENTER AND EXIT SITE AT THIS LOCATION"

## **TEMPORARY VEHICLE WASHDOWN & STABILIZED CONSTRUCTION ENTRANCE**



SCALE: NONE

### ***5.7 Pesticides, Herbicides, Insecticides, Fertilizers, and Landscape Materials***

There is no permanent landscaping being installed on this site, only re-vegetating with a seed mix. Therefore, contamination due to pesticides, herbicides, insecticides, and fertilizers is not a concern for this project.

### ***5.8 Other Pollution Prevention Practices***

Street Cleaning: If sediment is transported on to the street it will be removed from the street surface on a daily basis. Sediment will be shoveled and/or swept from the street and disposed of in a manner, which prevents contamination with storm water or surface water (e.g., covered soil stockpile). In addition, a street sweeper may be used to maintain clean roads on an as-needed basis. For 'offsite' trench work, all feasible care shall be made to contain excavated material and backfill material, and the adjacent street shall be swept daily during work days, and at other times as needed, to keep the traveled way and adjacent properties and/or drainages clean from mud, dust, silt, and debris.

## ***SECTION 6: INSPECTIONS & CORRECTIVE ACTIONS***

### ***6.1 Inspections***

**1. Inspection Personnel:** To be determined by contractor.

Insert Company or Organization Name:

Insert Name:

Insert Address:

Insert City, State, Zip Code:

Insert Telephone Number:

Insert Fax/Email:

Repeat as necessary

**2. Inspection Schedule and Procedures:**

Owner's Inspection Schedule: The owner shall provide inspection of the site by qualified personnel as described below to verify compliance with this SWPPP:

- A) at least once every fourteen calendar days for sites not finally stabilized.
- B) prior to anticipated storm events that could result in substantial runoff.
- C) within 24 hours after a storm that results in 0.5 in. Runoff or greater.
- D) at least once each month when runoff is unlikely or where sites have been stabilized until n.o.t. is filed.

Inspection Criteria: Points, areas, BMP's and activities to be inspected shall include the following:

- Disturbed areas and areas used for storage of materials that are exposed to precipitation shall be inspected for evidence of, or the potential for, pollutants entering the drainage system.
- Erosion and sediment control measures identified in the plan shall be observed to ensure that they are operating correctly.
- Where discharge locations or points are accessible, they shall be inspected to ascertain whether erosion control measures are effective in preventing significant impacts to receiving waters.
- Locations where vehicles enter or exit the site shall be inspected for evidence of offsite sediment tracking.

Inspection Induced Plan Revisions: Based on the results of the inspection, the site description identified in the plan and pollution prevention measures identified in the plan shall be revised as appropriate, but in no case later than 7 calendar days following the inspection. Such modifications shall provide for timely implementation of any changes to the plan within 7 calendar days following the inspection.

**Inspection Follow-Up:** Maintenance needs identified by inspections or by other means shall be accomplished before the next anticipated storm event, or as necessary to maintain the effectiveness of storm water controls. If maintenance prior to the next anticipated storm event is impracticable, maintenance must be scheduled and accomplished as soon as practicable. Maintenance done to address a concern noted on an inspection form shall be recorded on the same form, including the action taken and the date the action was taken, in order to show that the concern was addressed.

**Inspection Report:** A report summarizing the scope of the inspection, name(s) and qualifications of personnel making the inspection, the date(s) of the inspection, major observations relating to the implementation of the storm water pollution prevention plan (including the location (s) of discharges of sediment or other pollutants from the site and of any control device that failed to operate as designed or proved inadequate for a particular location), and actions taken shall be made at each inspection. These reports shall be retained as part of the storm water pollution prevention plan on-site during construction, and for at least three years for the date that the site is finally stabilized. Such reports shall identify any incidents of non-compliance. Where a report does not identify any incidents of non-compliance, the report shall contain a certification that the facility is in compliance with the storm water pollution prevention plan and this permit. Then report shall be signed by the contractor, inspector, and owner's representative. Contractor to attach a copy of the inspection report.

## **6.2 Corrective Actions**

See Appendix F. The corrective action log shall be used to describe the repair, replacement, and maintenance of BMP's undertaken as a result of the inspections and maintenance procedures described above. Actions related to the findings of inspections shall reference the specific inspection report.

## **6.3 Delegation of Authority**

**Duly Authorized Representative(s) or Position(s): To be determined by contractor.**

Insert Company or Organization Name:

Insert Name:

Insert Position:

Insert Address:

Insert City, State, Zip Code:

Insert Telephone Number:

Insert Fax/Email:

Attach a copy of the signed delegation of authority form in Appendix K.

## ***SECTION 7: TRAINING AND RECORDKEEPING***

### ***7.1 Training***

Training: Contractor will provide on-site training to key personnel responsible for compliance with the SWPPP. The contractor's superintendent and project manager will be familiarized with the major elements of the plan. Construction workers and others at the site will be given appropriate training information at the conclusion of site safety meetings or on an as-needed basis. The owner shall appoint an erosion and sediment control lead at the preconstruction conference who will take an active roll in applying the provisions of this plan onsite.

Preconstruction Conference: One or more preconstruction meetings will be held with an explicit agenda item addressing the SWPPP.

Coordination With Utilities and Other Contractors: All contractors providing services on the project which may cause storm water pollution will be given a copy of the SWPPP and appropriate training regarding storm water pollution prevention.

Subcontractor Oversight: Subcontractor oversight to ensure compliance with the SWPPP will be provided by the prime contractor's superintendent or project manager. Informal, on-the-job tailgate training will be the first level of communication followed by onsite observation of training compliance. Noncompliance with SWPPP policies will trigger a more intensive training session to correct the problem(s). Chronic non-compliance with SWPPP policies may require the intervention of local and/or state regulatory personnel.

Additional training documentation should be included in Appendix J.

### ***7.2 Recordkeeping***

Records will be retained for a minimum period of at least 3 years after the permit is terminated.

Date(s) when major grading activities occur:

See Appendix I

Date(s) when construction activities temporarily or permanently cease on a portion of the site:

Contractor to document and attach as needed.

Date(s) when an area is either temporarily or permanently stabilized:

Contractor to document and attach as needed.

Record Keeping: The owner shall retain copies of inspection reports, the SWPPP, the state notice of intent (n.o.i.) and any other applicable records for three years following the completion of the subdivision construction. A record of dates of major grading activities temporary cessations of construction activities, and initiation of stabilization measures shall be maintained by the contractor and kept with the inspection reports.

### ***7.3 Log of Changes to the SWPPP***

First Appraisal: This plan is designed as a first appraisal of necessary means to protect the waters of the state from potential pollution. It is the responsibility of the owner/operator to add warranted best management practices (BMP's) as necessary, modify those shown as appropriate, and delete from the project those found to be unnecessary. Federal and state law allows these updates to be made by the owner/operator onsite and recorded by the owner/operator on the copy of the SWPPP kept onsite. All such changes shall be marked on the site maps and/or in the SWPPP as appropriate and logged in this section.

When To Amend: This plan shall be amended whenever:

- a) there is a change in design, construction, operation, or maintenance that has a substantial effect on the discharge of pollutants to the waters of the state.
- b) inspections or investigations by officials indicate that the plan is ineffective in eliminating, minimizing, or controlling the discharge of pollutants associated with construction activity
- c) there is a new contractor or subcontractor that implements a measure of the storm water pollution prevention plan.
- d) there is a change in state or federal regulations that applies to this SWPPP.
- e) BMP's not referenced in plan are used on site.

Tracking Amendments: Amendments and revisions to this plan shall be noted in the revision block on the title block (on the right side of each sheet), including type of changes and date of changes. Changes shall be marked with revision clouds on plan sheets with keyed references to revision numbers. After changes are made, owner, engineer, and contractor shall sign amended plan which is then the plan to be kept on site. Superseded plan shall be filed by owner or contractor with inspection reports.

Deviations From Plans: Any deviations from the plans as shown during construction shall be brought to the attention of design engineering for evaluation as to whether the changes affect the storm water pollution prevention plan.

Partial Transfer Of Ownership: If ownership of a portion of the project is transferred to another before filing of the notice of termination (n.o.t.), liability for storm water pollution prevention for the parcel shall be transferred to the new owner by contract. The new owner shall be responsible to conduct operations in such a manner as to not interfere with this plan, and in accordance with all local, state, and federal regulations.

Log of changes and updates to the SWPPP

See Appendix F

## ***SECTION 8: WATER QUALITY***

### ***8.1 UIC Class 5 Injection Wells***

There will be no UIC Class 5 Injections Wells in this project.

### ***8.2 Discharge Information***

Does your project/site discharge storm water into a Municipal Separate Storm Sewer System (MS4)?  Yes  No

Are there any surface waters that are located within 50 feet of your construction disturbances?  
 Yes  No

### ***8.3 Receiving Waters***

There are no receiving waters within reasonable distance from the site. It is assumed that all storm water will percolate into the ground before coming into contact with any receiving waters.

### ***8.4 Impaired Waters***

There are no impaired waters within reasonable distance from the site.

### ***8.5 High Water Quality***

Not applicable to project.

### ***8.6 Dewatering Practices***

No dewatering will be occurring on this site.

### ***8.7 Control Storm Water Flowing onto and through the Project***

Runoff Interception: Before being discharged from the construction site, sediment-contaminated storm water will be processed in the storm water treatment system including sediment traps and/or sedimentation basins. Clean water bypassing the site will be routed directly to the receiving system.

Run-On Bypass: Clean storm water run-on draining from the up gradient, undisturbed eastern portion of the site will be collected prior to entering the construction areas and diverted to the



southern stream via enclosed pipe. This water will be routinely monitored to ensure only clean water is discharged to the stream. If the water becomes contaminated, it will be routed to the detention system for treatment.

**Temporary Measures:** Drainage swales, silt fences, and temporary culverts will channel all runoff contaminated with sediment or otherwise affected by construction activities into temporary sedimentation basins. Storm events of higher intensity and/or longer duration will not be completely retained, but the sedimentation basins will provide an opportunity for sedimentation before the water leaves the site. All ditches and other water conveyances draining active construction areas to the sedimentation basins will be stabilized with rock, matting, or other stabilizing method with check dams or sediment traps placed as needed to reduce water velocities and settle out as much sediment as possible prior to entering the temporary sedimentation ponds. Sediment must be removed from sedimentation ponds and sediment traps when design capacity has been reduced by 50%.

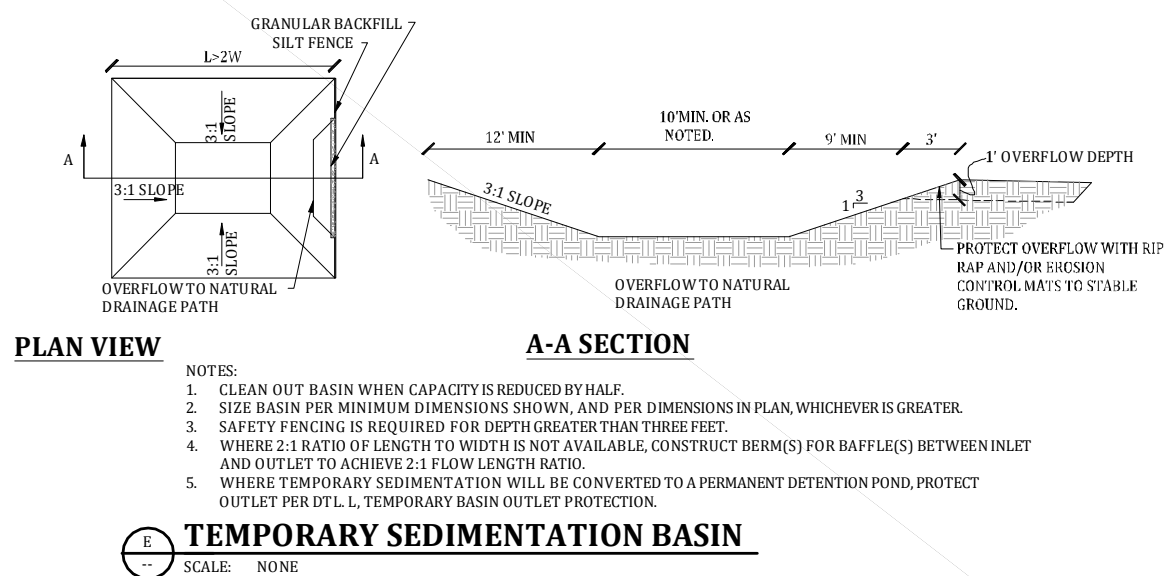

**Drainage Swale:** Drainage swales shall be used to capture contaminated runoff before exiting the site, to capture wash water, and other sediment laden storm flows and convey the flow to sedimentation basins for treatment. Stabilization of the swale with rip rap, erosion control mats, check dams, and/or sediment traps is required per the following details.

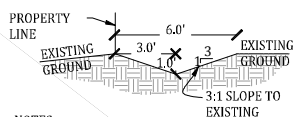

- NOTES:**
1. PROTECT CHANNEL FROM EROSION AS NECESSARY WITH RIP RAP, EROSION CONTROL MATS AND/OR ROCK CHECK DAMS
  2. SEDIMENT TRAPS REQUIRED AT 200' SPACING OR AS SHOWN ON PLANS, WHICHEVER IS MORE STRINGENT.
  3. FOR SWALES STEEPER THAN 5%, STABILIZE SWALES WITH RIP RAP LINING IN SWALE AND ROCK CHECK DAMS SPACED AT EVERY THREE FEET OF DROP IN FLOWLINE.

**C DRAINAGE SWALE**  
SCALE: NONE

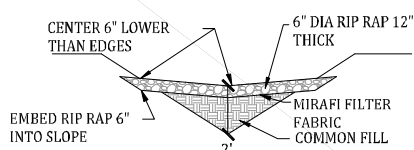

**A-A' SECTION**

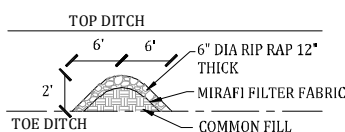

**B-B' SECTION**

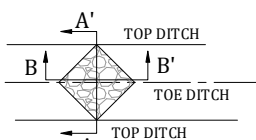

**PLAN VIEW**

- NOTES:**
1. PLACE CHECK DAMS PERPENDICULAR TO FLOW DIRECTION
  2. DO NOT PLACE DAMS ACROSS NATURAL STREAM BEDS
  3. CONSTRUCT CHECK DAMS SO THAT WATER DOES NOT FLOW AROUND THE ENDS OF THE DAM.
  4. REMOVE ACCUMULATED SEDIMENT WHEN DEPTH REACHES 1 FOOT.

**F ROCK CHECK DAM**  
SCALE: NONE

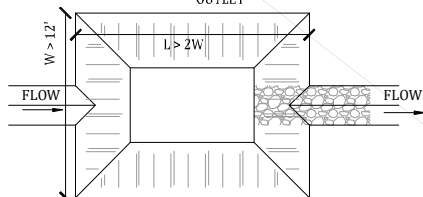
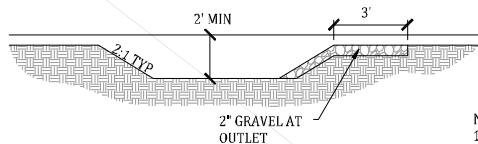

**PLAN VIEW**

- NOTES:**
1. PLACE SEDIMENT TRAPS AT LOCATIONS SHOWN ON PLANS, AND WHEREVER APPROPRIATE TO INTERCEPT SEDIMENT LADEN FLOW ON SITE.
  2. MAINTAIN PROPER FUNCTION OF SEDIMENT TRAP UNTIL DISTURBED AREAS CONTRIBUTING TO BASIN HAVE BEEN PAVED OR REVEGETATED.
  3. REMOVE ACCUMULATED SEDIMENT WHEN CAPACITY IS DECREASED BY HALF.

**H SEDIMENT TRAP**  
SCALE: NONE

**Temporary Silt Fence:** Temporary Silt Fence shall be installed at the downhill edge of disturbed areas, where drainage swales are not present, to prevent sediment-laden water from exiting the disturbed area and contaminating neighboring undisturbed ground or running off into the storm water system. Silt fence shall be installed parallel to contours for slopes steeper than 5%, such that the line of silt fence downhill overlaps the line of the silt fence by a minimum of five feet.

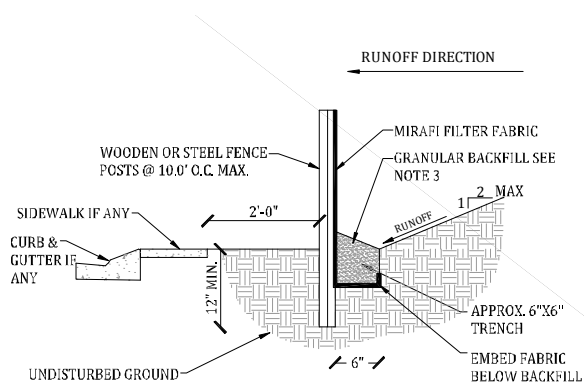

1. EXCAVATE 6" X 6" TRENCH ALONG LIMITS OF DISTURBANCE AS SHOWN ON CONSTRUCTION DRAWINGS.
2. POSTS SHALL BE POSITIONED ON DOWNSTREAM SIDE OF FENCE.
3. LAY TOE-IN FABRIC FLAP IN BOTTOM OF TRENCH, BACKFILL TRENCH WITH FREE DRAINING GRANULAR MATERIAL, COMPACT TRENCH TO SATISFACTION OF THE ENGINEER OF RECORD.
4. SILT FENCE GEOTEXTILE SHALL MEET AASHTO M288-92 REQUIREMENTS.
5. REMOVE & DISPOSE OF SEDIMENT WHEN ACCUMULATION IS 50% OF EXPOSED FENCE HEIGHT.
6. 10' MAX. SPACING BETWEEN STAKES.
7. SILT FENCES SHALL BE INSTALLED ALONG CONTOURS, NOT UP AND DOWN SLOPES, WITH 10' OVERLAP AT BREAKS.

**B** **TEMPORARY SILT FENCE**  
 SCALE: NONE

**Filter Strip:** Temporary sedimentation pond overflows shall discharge across erosion control mat or rip rap, and permanent detention basins shall discharge across rip rap, allowing sediment and other contaminants to be intercepted before reaching receiving waters, and to protect discharge from erosion.

**Outlet Protection:** Adequate energy dissipation, erosion control, and soil stabilization measures (e.g., rock or other energy dissipation techniques) will be provided for all point source discharges of storm water, including run-on discharges and outlets from onsite discharges.

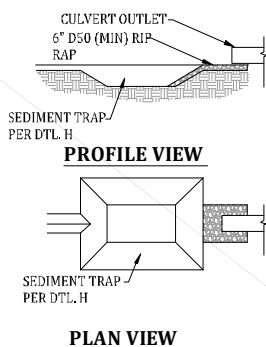

**0** **OUTLET PROTECTION**  
 SCALE: NONE

**Permanent Storm Drain System:** Once the storm drain improvements are in place water will be channeled to a permanent detention basin. The outlet from the detention basin shall be protected per project details to cause pond to function as a sedimentation basin until land is stabilized. Permanent drainage swales may also be used to capture contaminated runoff, and shall be protected and maintained.

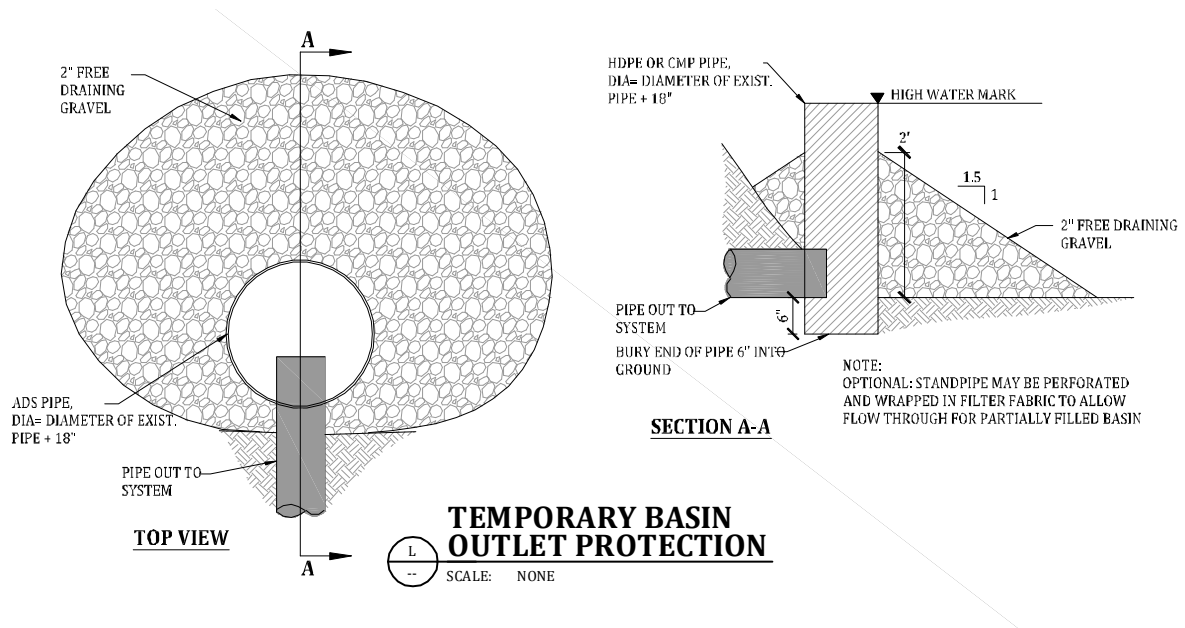

### 8.8 Protect Storm Drain Inlets

There is no existing or proposed storm drain system on this site.

## ***SECTION 9: POST-CONSTRUCTION BMPs***

After construction has been completed the following steps shall be taken to close out the project:

Revegetation: All remaining disturbed land shall be reseeded with native grass mixture and protected until grasses are established.

Removal of Temporary BMP's: All temporary erosion and sediment control BMP's will be removed within 30 days after final site stabilization is achieved or after the temporary BMP's are no longer needed. Trapped sediment will be removed or stabilized on site. Disturbed soil areas resulting from removal of BMP's or vegetation will be permanently stabilized as soon as possible.

Cleanup: All inlets and junctions shall be cleaned. All waste materials shall be removed and properly disposed of.

Notice of Termination (N.O.T.): After completion of the subdivision construction and cleanup, the owner shall file a N.O.T. with the state DEQ Division of Water Quality to certify that construction activities have been completed and the site properly cleaned up and commissioned.

Subsequent Construction Projects: future phases and adjacent projects are not covered by this SWPPP and shall be handled separately. During the construction of individual homes and lot sites, liability for storm water pollution prevention for the lots in question shall be transferred to the new owner(s) by contract. The new owner(s) shall be responsible to conduct operations in such a manner as to not interfere with this plan, and in accordance with all local, state, and federal regulations.

Transfer of Ownership/Responsibility: After initial revegetation and stabilization, and transfer of ownership to city of public right of way and public parcels including detention basins, it will be the responsibility of the city to maintain the public right of way and detention basin BMP's including but not limited to the storm drainage system, detention basin, and rip rap. It will be the responsibility of the homeowners' association to maintain landscaping in common spaces. It will be the responsibility of the individual property owners to maintain private property in compliance with all applicable laws and ordinances.

## ***SECTION 10: CERTIFICATION***

### ***Professional/SWPPP Author***

I certify under penalty of law that this document and all attachments were prepared under my direction or supervision in accordance with a system designed to assure that qualified personnel properly gathered and evaluated the information submitted. Based on my inquiry of the person or persons who manage the system, or those persons directly responsible for gathering the information, the information submitted is, to the best of my knowledge and belief, true, accurate, and complete. I am aware that there are significant penalties for submitting false information, including the possibility of fine and imprisonment for knowing violations.

Name: \_\_\_\_\_ Title: \_\_\_\_\_

Signature: \_\_\_\_\_ Date: \_\_\_\_\_

Repeat as needed for construction operator(s) at the site

## ***SWPPP APPENDICES***

Attach the following documentation to the SWPPP:

***Appendix A – General Location Map***

***Appendix B – Site Maps***

***Appendix C – Construction General Permit***

***Appendix D – NOI and Acknowledgement Letter from EPA/State/MS4***

***Appendix E – Inspection Reports***

***Appendix F – Corrective Action Log (or in Part 5.3)***

***Appendix G – SWPPP Amendment Log (or in Part 7.4)***

***Appendix H – Subcontractor Certifications/Agreements***

***Appendix I – Grading and Stabilization Activities Log***

***Appendix J – Training Log***

***Appendix K – Delegation of Authority***

***Appendix L – Additional Information (i.e. Documentation; other permits such as dewatering, stream alteration, wetland; and out of date swppp documents)***

***Appendix M – BMP Specifications***

## Appendix A – General Location Map

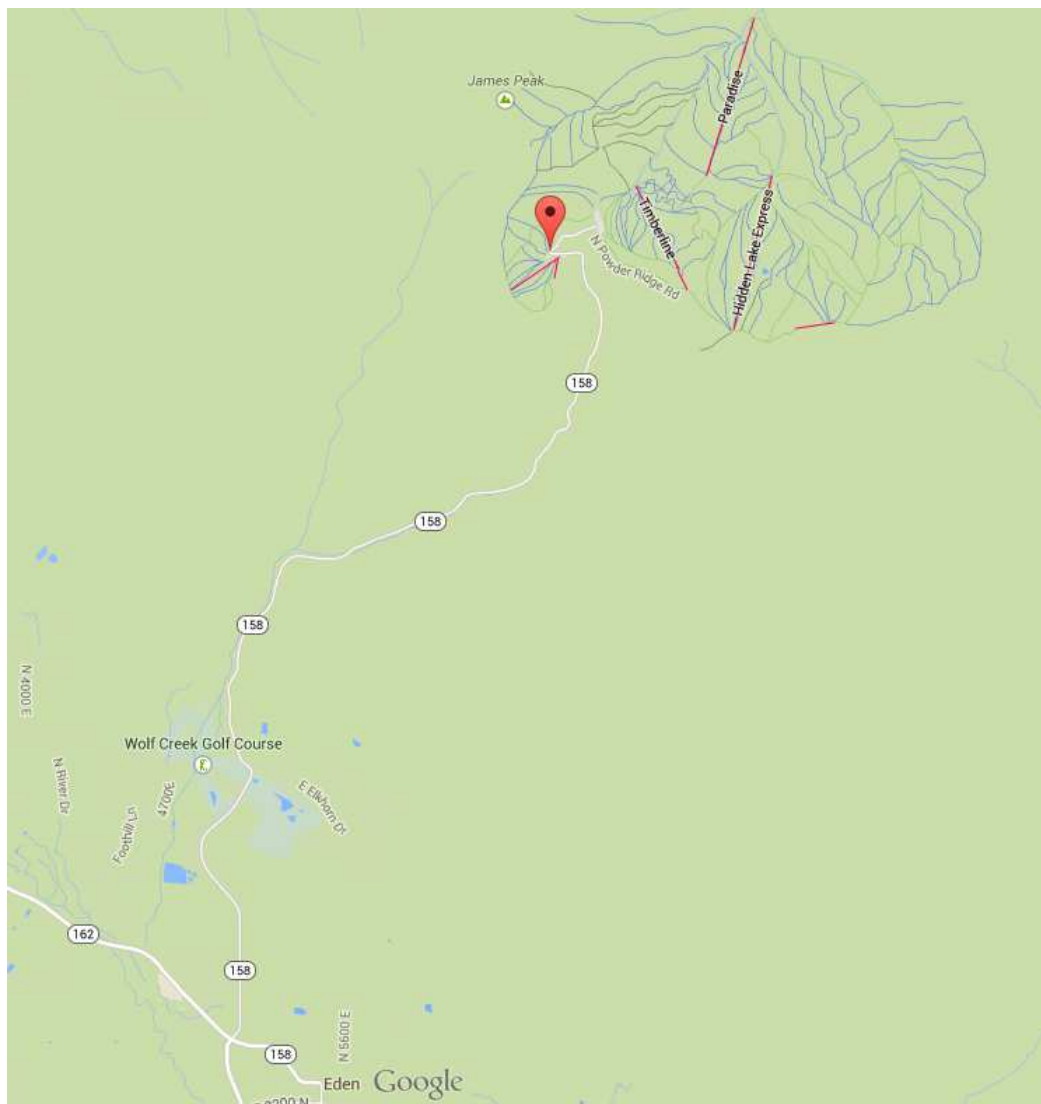



## Appendix B – Site Maps

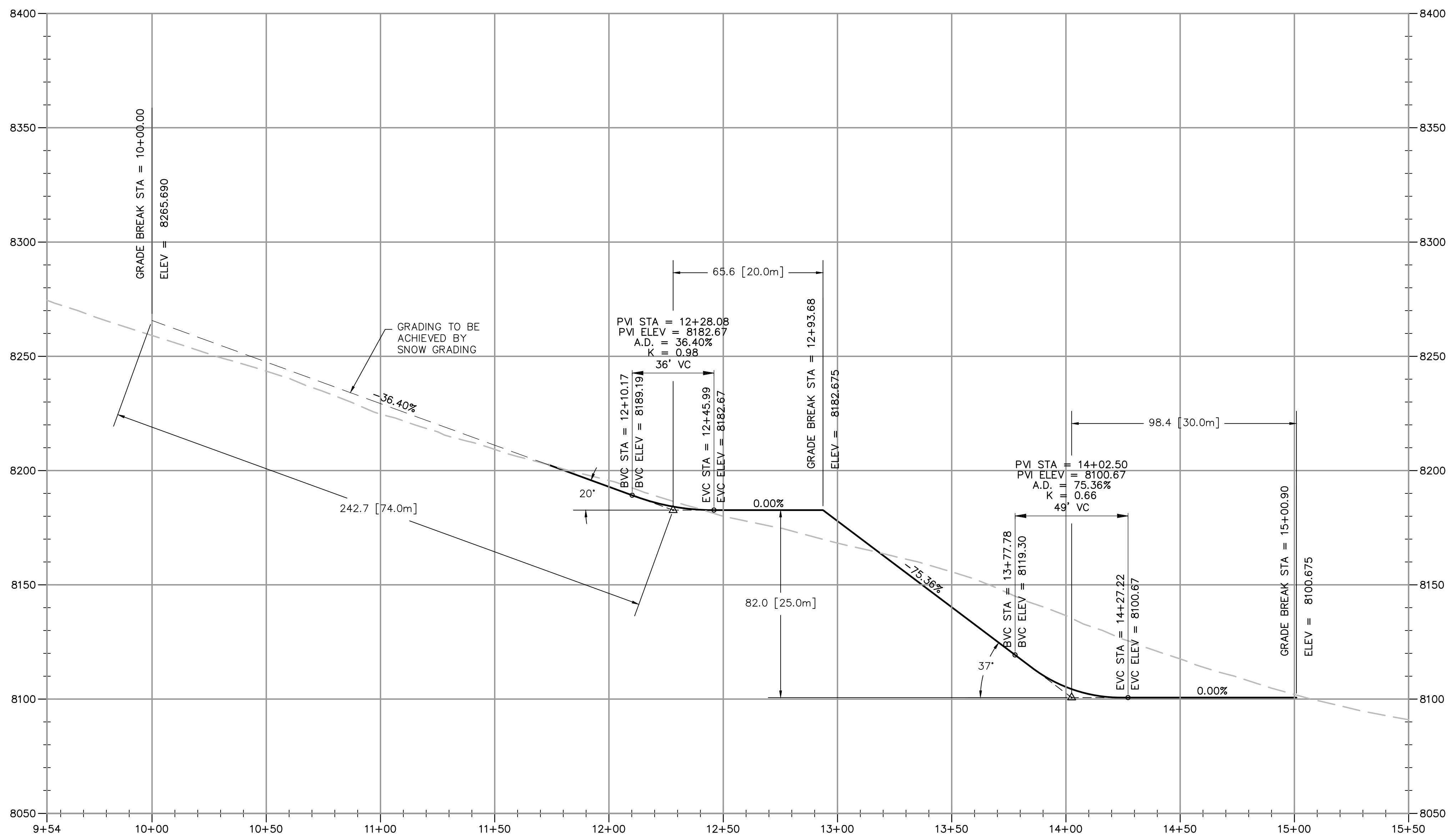
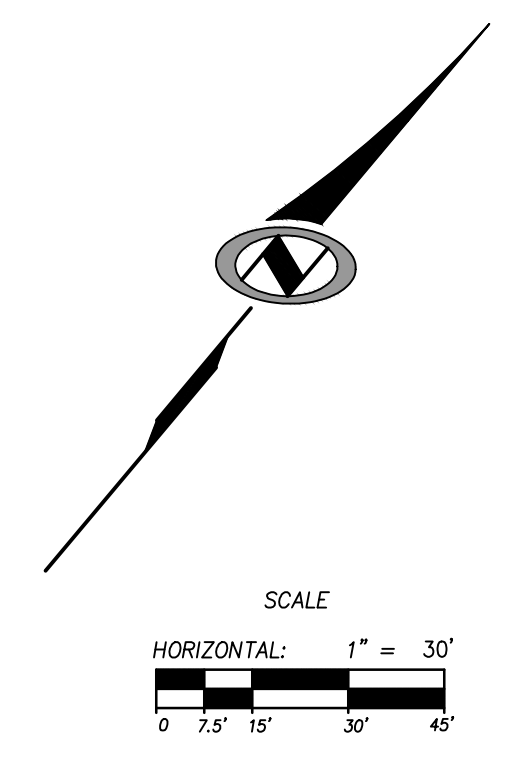
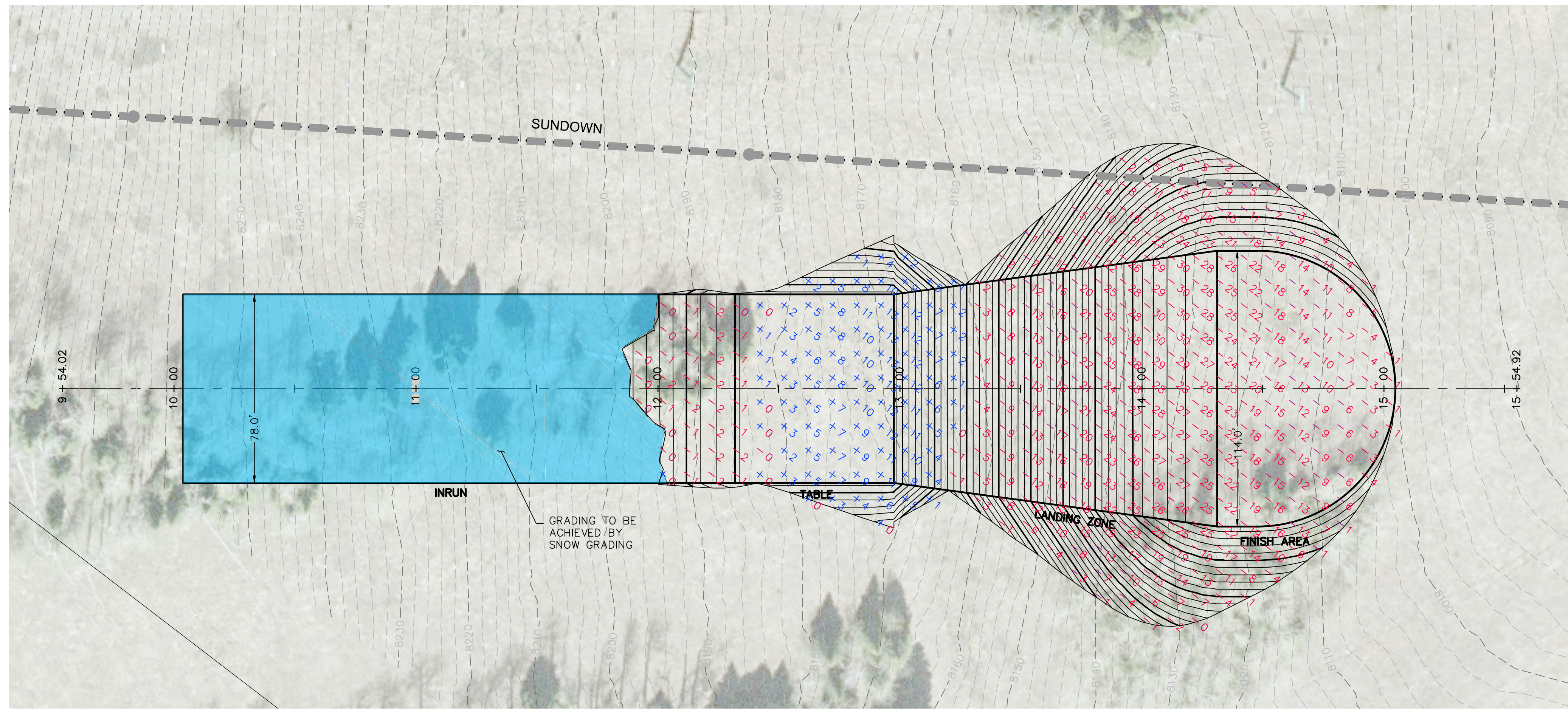

NO.	BY	DATE	REVISIONS

# POWDER MOUNTAIN

## SUNDOWN SKI JUMP

### SITE & GRADING PLAN

DATE SUBMITTED: 11/06/2014

PREPARED FOR: WATTS

**NV5**  
 BEYOND ENGINEERING

MURRAY, UT 84107  
 WWW.NV5.COM

6217 SOUTH STATE STREET, SUITE 200  
 801743.8800 TEL. 801743.0800 FAX

SHEET NUMBER  
**1**  
 OF 2 SHEETS

SCALE  
 VERTICAL: 1" = 30'  
 HORIZONTAL: 1" = 30'

JOB NUMBER  
**SLB0793**

The engineer preparing these plans will not be responsible for, or liable for, unauthorized changes to or uses of these plans. All changes and uses must be approved by the preparer of these plans.

CAUTION

**EROSION CONTROL GENERAL NOTES:**

THE CONTRACTOR TO USE BEST MANAGEMENT PRACTICES FOR PROVIDING EROSION CONTROL FOR CONSTRUCTION OF THIS PROJECT. ALL MATERIAL AND WORKMANSHIP SHALL CONFORM TO WEBER COUNTY ORDINANCES AND ALL WORK SHALL BE SUBJECT TO INSPECTION BY THE COUNTIES. ALSO, INSPECTORS WILL HAVE THE RIGHT TO CHANGE THE FACILITIES AS NEEDED.

CONTRACTOR SHALL KEEP THE SITE WATERED TO CONTROL DUST. CONTRACTOR TO LOCATE A NEARBY HYDRANT FOR USE AND TO INSTALL TEMPORARY METER. CONSTRUCTION WATER COST TO BE INCLUDED IN BID.

WHEN GRADING OPERATIONS ARE COMPLETED AND THE DISTURBED GROUND IS LEFT "OPEN" FOR 14 DAYS OR MORE, THE AREA SHALL BE FURROWED PARALLEL TO THE CONTOURS.

THE CONTRACTOR SHALL MODIFY EROSION CONTROL MEASURES TO ACCOMMODATE PROJECT PLANNING.

ALL ACCESS TO PROPERTY WILL BE FROM PUBLIC RIGHT-OF-WAYS.

**MAINTENANCE:**

ALL BEST MANAGEMENT PRACTICES (BMP'S) SHOWN ON THIS PLAN MUST BE MAINTAINED AT ALL TIMES UNTIL VEGETATION IS RE-ESTABLISHED.

THE CONTRACTOR'S RESPONSIBILITY SHALL INCLUDE MAKING BI-WEEKLY CHECKS ON ALL EROSION CONTROL MEASURES TO DETERMINE IF REPAIR OR SEDIMENT REMOVAL IS NECESSARY. CHECKS SHALL BE DOCUMENTED AND COPIES OF THE INSPECTIONS KEPT ON SITE.

SEDIMENT DEPOSITS SHOULD BE REMOVED AFTER EACH RAINFALL. THEY MUST BE REMOVED WHEN THE LEVEL OF DEPOSITION REACHES APPROXIMATELY ONE-HALF THE HEIGHT OF BARRIER.

SEDIMENT TRACKED ONTO PAVED ROADS MUST BE CLEANED UP AS SOON AS PRACTICAL, BUT IN NO CASE LATER THAN THE END OF THE NORMAL WORK DAY. THE CLEAN UP WILL INCLUDE SWEEPING OF THE TRACKED MATERIAL, PICKING IT UP, AND DEPOSITING IT TO A CONTAINED AREA.

**EXPOSED SLOPES:**

ANY EXPOSED SLOPE THAT WILL REMAIN UNTOUCHED FOR LONGER THAN 14 DAYS MUST BE STABILIZED BY ONE OR MORE OF THE FOLLOWING METHODS:

- A) SPRAYING DISTURBED AREAS WITH A TACKIFIER VIA HYDROSEED
- B) TRACKING STRAW PERPENDICULAR TO SLOPES
- C) INSTALLING A LIGHT-WEIGHT, TEMPORARY EROSION CONTROL BLANKET

**CONTACT PERSON:**

PERSON RESPONSIBLE FOR IMPLEMENTATION OF EROSION CONTROL PLAN IS ROGER ARAVE, 801-940-0665.

**SCOPE OF WORK:**

PROVIDE, INSTALL AND/OR CONSTRUCT THE FOLLOWING PER THE SPECIFICATIONS GIVEN OR REFERENCED, THE DETAILS NOTED, AND/OR AS SHOWN ON THE CONSTRUCTION DRAWINGS:

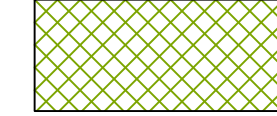
 HATCHING INDICATES AREAS TO HAVE TOPSOIL STRIPPED AND BERMED ALONGSIDE THE PROJECT LIMITS. AFTER GRADING IS COMPLETE, TOPSOIL TO BE RESTORED OVER DISTURBED AREA AND TRACKED PARALLEL TO SLOPE. DISTURBED AREA TO BE RE-VEGETATED WITH SEED MIX LISTED BELOW AND APPLIED WITH SPRAYMATT BONDED FIBER MATRIX BY CENTRAL FIBER. APPLY PER MANUFACTURERS SPECIFICATIONS.

 INSTALL SILT FENCE ALONG DOWN GRADIENT LIMITS OF DISTURBANCE AS SHOWN ON PLAN.

 EXISTING GRAVEL PARKING AREA TO SERVE AS STABILIZED CONSTRUCTION ENTRANCE FOR SITE INGRESS/EGRESS. SUPPLY WATER FOR VEHICLE WASH DOWN AS NEEDED.

 LIMITS OF DISTURBANCE

- \* SEED MIXTURE FOR REVEGITATION
- 40% MOUNTAIN BROME (BROMUS MARGINATUS)
  - 25% SLENDER WHEATGRASS (ELYMUS TRACHYCAULUS SSP. TRACHYCAULUS)
  - 5% SHEEP FESCUE (FESTUCA OVINA SPP. DURIUSCULA)
  - 5% ALPINE BLUEGRASS (POA ALPINE)
  - 25% THICKSPIKE WHEATGRASS (ELYMUS LANCEOLATUS SSP. LANCEOLATUS)

SEEDING RATE IS 40 POUNDS PER ACRE.

TOTAL DISTURBED AREA =0.90 ACRES

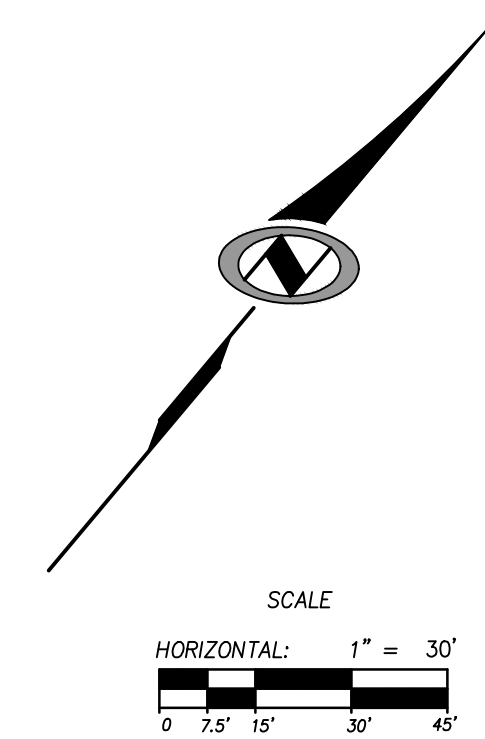
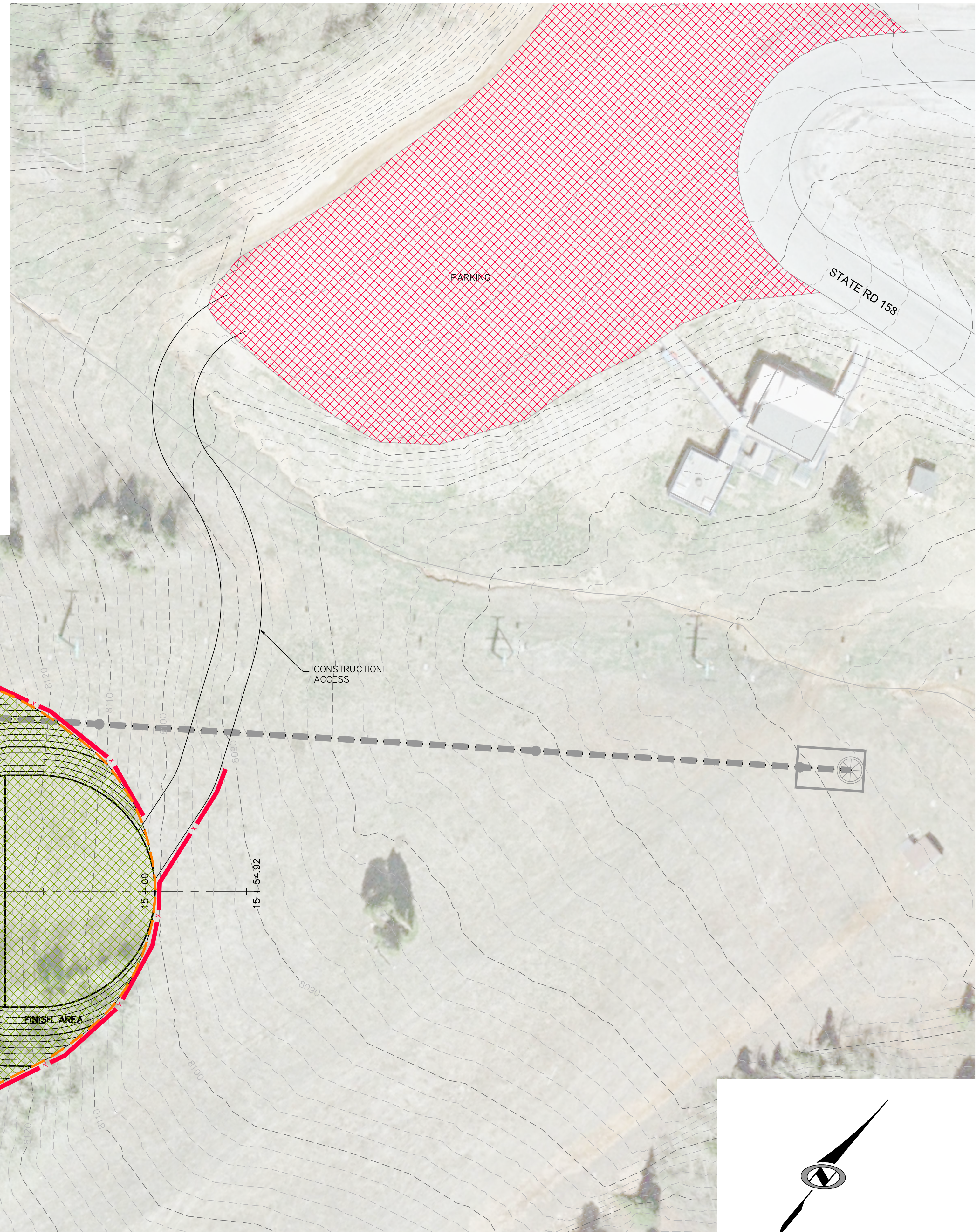

**POWDER MOUNTAIN  
 SUNDOWN SKI JUMP  
 EROSION CONTROL PLAN**

PREPARED FOR: WATTS

MURRAY, UT 84007  
 WWW.NV5.COM

**NV5**  
 BEYOND ENGINEERING

6217 SOUTH STATE STREET, SUITE 200  
 801743.8000 TEL. 801743.0800 FAX

SHEET NUMBER	2
OF	2 SHEETS
SCALE	HORIZONTAL: 1" = 30' VERTICAL: 1" = 30'
JOB NUMBER	SLB0793

CAUTION  
 The engineer preparing these plans will not be responsible for, or liable for, unauthorized changes to or uses of these plans. Any such changes and uses must be approved by the preparer of these plans.

DATE SUBMITTED: 11/06/2014

## Appendix C – Construction General Permit (UTR 3000000)

## Appendix D – NOI and Acknowledgement Letter from EPA/State

## Appendix E – Inspection Reports







## Appendix H – Subcontractor Certifications/Agreements

### SUBCONTRACTOR CERTIFICATION STORMWATER POLLUTION PREVENTION PLAN

Project Number: \_\_\_\_\_

Project Title: \_\_\_\_\_

Operator(s): \_\_\_\_\_

As a subcontractor, you are required to comply with the Stormwater Pollution Prevention Plan (SWPPP) for any work that you perform on-site. Any person or group who violates any condition of the SWPPP may be subject to substantial penalties or loss of contract. You are encouraged to advise each of your employees working on this project of the requirements of the SWPPP. A copy of the SWPPP is available for your review at the office trailer.

Each subcontractor engaged in activities at the construction site that could impact stormwater must be identified and sign the following certification statement:

**I certify under the penalty of law that I have read and understand the terms and conditions of the SWPPP for the above designated project and agree to follow the BMPs and practices described in the SWPPP.**

This certification is hereby signed in reference to the above named project:

Company: \_\_\_\_\_

Address: \_\_\_\_\_

Telephone Number: \_\_\_\_\_

Type of construction service to be provided: \_\_\_\_\_

\_\_\_\_\_  
\_\_\_\_\_

Signature: \_\_\_\_\_

Title: \_\_\_\_\_

Date: \_\_\_\_\_



## Appendix J – SWPPP Training Log

### Stormwater Pollution Prevention Training Log

Project Name:

Project Location:

Instructor's Name(s):

Instructor's Title(s):

Course Location: \_\_\_\_\_ Date: \_\_\_\_\_

Course Length (hours): \_\_\_\_\_

Stormwater Training Topic: *(check as appropriate)*

- Erosion Control BMPs       Emergency Procedures  
 Sediment Control BMPs       Good Housekeeping BMPs  
 Non-Stormwater BMPs

Specific Training Objective: \_\_\_\_\_  
\_\_\_\_\_

Attendee Roster: *(attach additional pages as necessary)*

No.	Name of Attendee	Company
1		
2		
3		
4		
5		
6		
7		
8		
9		
10		

## Appendix K – Delegation of Authority Form

### Delegation of Authority

I, \_\_\_\_\_ (name), hereby designate the person or specifically described position below to be a duly authorized representative for the purpose of overseeing compliance with environmental requirements, including the Construction General Permit, at the \_\_\_\_\_ construction site. The designee is authorized to sign any reports, stormwater pollution prevention plans and all other documents required by the permit.

\_\_\_\_\_ (name of person or position)  
\_\_\_\_\_ (company)  
\_\_\_\_\_ (address)  
\_\_\_\_\_ (city, state, zip)  
\_\_\_\_\_ (phone)

By signing this authorization, I confirm that I meet the requirements to make such a designation as set forth in \_\_\_\_\_ (Reference State Permit), and that the designee above meets the definition of a “duly authorized representative” as set forth in \_\_\_\_\_ (Reference State Permit).

I certify under penalty of law that this document and all attachments were prepared under my direction or supervision in accordance with a system designed to assure that qualified personnel properly gathered and evaluated the information submitted. Based on my inquiry of the person or persons who manage the system, or those persons directly responsible for gathering the information, the information submitted is, to the best of my knowledge and belief, true, accurate, and complete. I am aware that there are significant penalties for submitting false information, including the possibility of fine and imprisonment for knowing violations.

**Name:** \_\_\_\_\_

**Company:** \_\_\_\_\_

**Title:** \_\_\_\_\_

**Signature:** \_\_\_\_\_

**Date:** \_\_\_\_\_