

Val's Subdivision First Amendment to Lot 7

Weber County, Utah
 A Part of the Northeast Quarter of Section 20,
 Township 6 North, Range 2 West, Salt Lake Base & Meridian
 January, 2015

SURVEYOR'S CERTIFICATE

I, K. Greg Hansen, do hereby certify that I am a Registered Professional Land Surveyor in the State of Utah in accordance with Title 58, Chapter 22, Professional Engineers and Land Surveyors Act; and I have completed a Survey of the Property Described on this Plat in accordance with Section 17-23-17 and have verified all measurements, and have placed monuments as represented on this Plat, and have hereby amended said tract, know hereafter as Val's Subdivision First Amendment to Lot 7 in Weber County, Utah, and has been correctly drawn to the designated scale and is true and correct representation of the herein described lands included in said subdivision, based upon data compiled from records in the Weber County Recorder's Office and from said survey made by me on the ground. I further hereby certify that the requirements of all applicable statutes and ordinances of Weber County concerning zoning requirements regarding lot measurements have been complied with.

Signed this _____ day of _____, 2014.

K. Greg Hansen P.L.S.
 Utah Land Surveyor License No. 167819

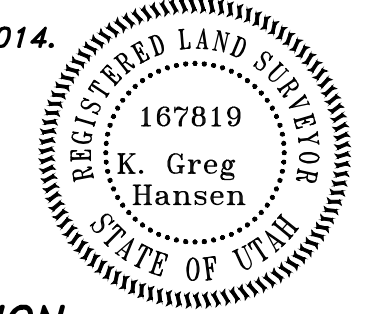

BOUNDARY DESCRIPTION

BEING SITUATED IN THE NORTHEAST QUARTER OF SECTION 20, TOWNSHIP 6 NORTH, RANGE 2 WEST OF THE SALT LAKE BASE AND MERIDIAN, MORE PARTICULARLY DESCRIBED AS FOLLOWS:

BEGINNING AT THE NORTHWEST CORNER OF SAID LOT 7 BEING LOCATED 56.00 FEET NORTH 00°22'00" EAST AND 740.01 FEET SOUTH 89°29'45" EAST AND 441.53 FEET NORTH 00°22'00" EAST AND 392.86 FEET SOUTH 89°38'00" EAST FROM THE SOUTHWEST CORNER OF SAID NORTHEAST QUARTER; RUNNING THENCE SOUTH 89°38'00" EAST 154.00 FEET; THENCE SOUTH 00°10'00" WEST 259.40 FEET; THENCE NORTH 89°29'00" WEST 154.91 FEET (154.93 FEET BY RECORD); THENCE NORTH 00°22'00" EAST 258.99 FEET TO THE POINT OF BEGINNING. CONTAINING 40033 SQUARE FEET OR 0.919 ACRES.

NARRATIVE

The Purpose of this Survey was to Amend Lot 7, Val's Subdivision to remove the 10.0' wide ditch easement that goes through Lot 7 and the storm water detention easement that is situated on Lot 7 as recorded on the original plat as Shown and Described Hereon and to add the 10.0' PUE along the south side of Lot 7. This Survey was Ordered by Cory McCubbin. The Control used to Establish the Property Corners was the Existing Weber County Surveyor Monumentation Surrounding Section 20, Township 6 North, Range 2 West, S.L.B.&M. The basis of bearing is the West line of the Northeast Quarter of said Section which bears North 00°22'00" East Per the Val's Subdivision Plat (North 00°45'17" East, Utah North, State Plane, Calculated N.A.D.83 Bearing).

OWNER'S DEDICATION AND CERTIFICATION

Know all men by these presents that we, the undersigned Owners of the above described tract of land having caused the same to be Amended as shown on this plat and name said tract Val's Subdivision First Amendment to Lot 7 and hereby dedicate, grant and convey, in perpetuity, pursuant to the provisions of 17-27a-607, Utah code, without condition, restriction or reservation to Weber County, Utah, all those those certain strips as easements for public utility and drainage purposes as shown hereon. The same to be used for the installation, maintenance and operation of public utility service lines and drainage as may be authorized by the Governing Authority in witness we have here unto set our signature this _____ day of _____, 2014.

Cory McCubbin Tina Marie McCubbin

ACKNOWLEDGMENT

State of Utah
 County of _____
 On this _____ day of _____, 2014, Cory McCubbin and Tina Marie McCubbin, Husband and Wife as Joint Tenants, Personally Appeared before me, the Undersigned Notary Public in and for said County of Weber, in the State of Utah, the Signers of the Attached Owners Dedication, two in Numbers, who duly Acknowledged to me they Signed it Freely and Voluntarily and for the Purpose Therein Mentioned.

Notary Public

WEBER COUNTY RECORDER

ENTRY NO. _____ FEE PAID _____
 FILED FOR RECORD AND
 RECORDED _____
 IN BOOK _____ OF OFFICIAL
 RECORDS, PAGE _____, RECORDED
 FOR _____
 COUNTY RECORDER
 BY: _____ DEPUTY

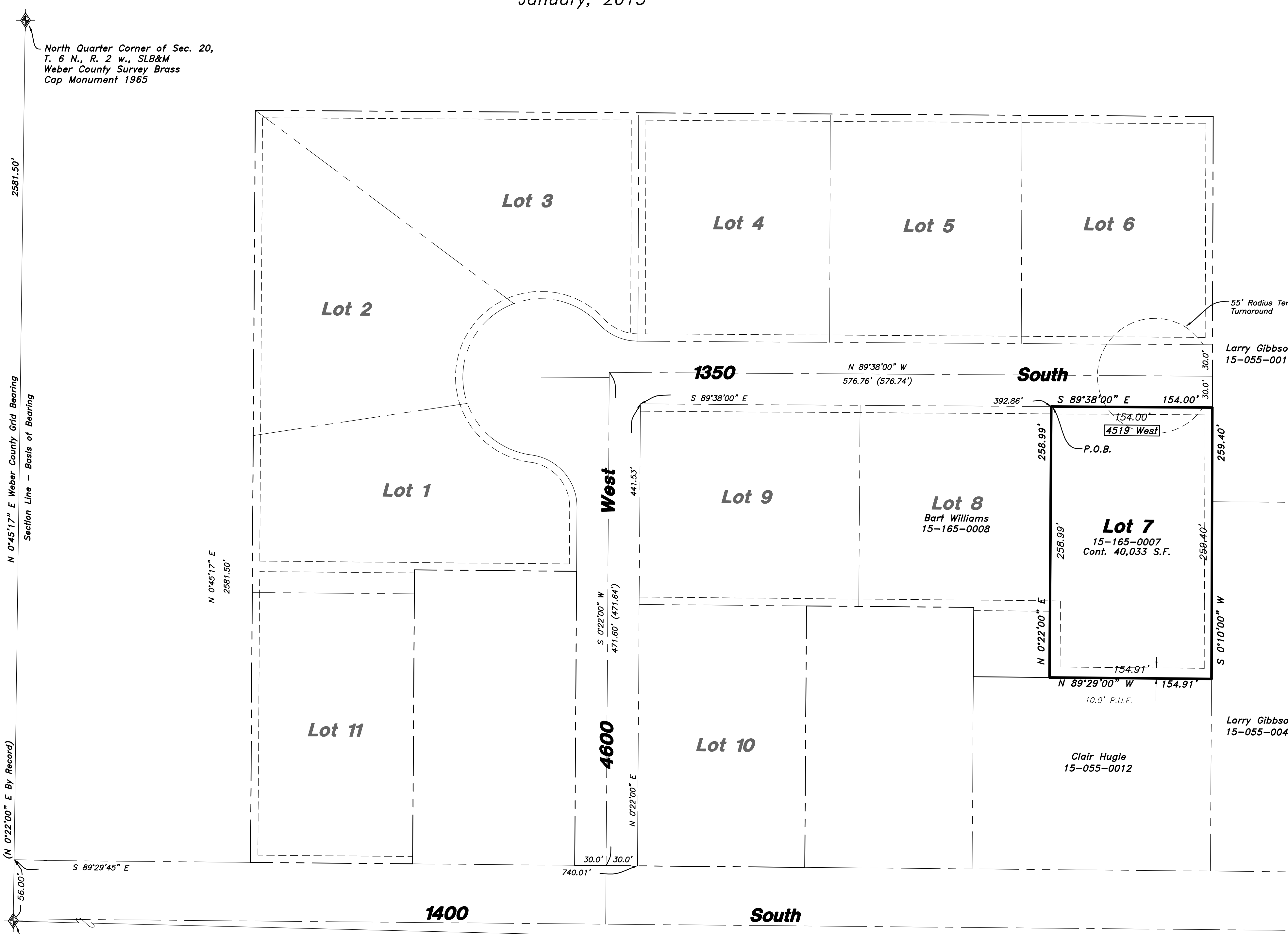

North Quarter Corner of Sec. 20,
 T. 6 N., R. 2 W., SLB&M
 Weber County Survey Brass
 Cap Monument 1965

N 0°45'17" E Weber County Grid Bearing
 Section Line - Basis of Bearing

(N 0°22'00" E By Record)

Southwest Corner of the Northeast
 Quarter of Sec. 20, T. 6 N., R. 2 W.,
 SLB&M Weber County Survey Brass
 Cap Monument 1963.

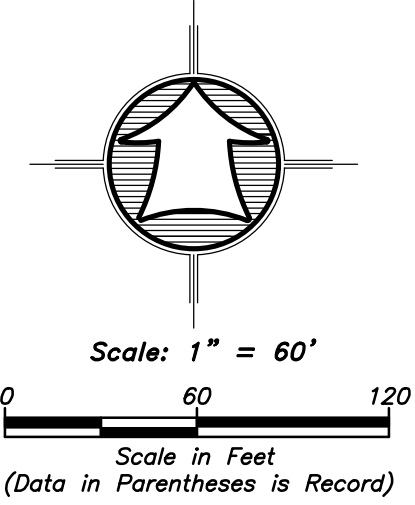

WEBER COUNTY ENGINEER

I hereby certify that the Required Public Improvement Standards and Drawings for this Subdivision Conform with the County Standards and the Amount of the Financial Guarantee is Sufficient for the Installation of these Improvements.
 Signed this _____ Day of _____, 2014.

 Weber County Engineer

WEBER COUNTY PLANNING COMMISSION APPROVAL

This is to Certify that this Subdivision Plat was Duly Approved by the Weber County Planning Commission.
 Signed this _____ Day of _____, 2014.

 Chairman, Weber County Planning Commission

Developers Name: Cory McCubbin
 Address: 4519 West 1350 South
 West Weber, Utah 84401
 Phone No.: 801-814-4890

HAI
HANSEN & ASSOCIATES, INC.
 Consulting Engineers and Land Surveyors
 538 North Main Street, Brigham, Utah 84302
 Visit us at www.haies.net
 Brigham City Ogden Logan
 (435) 723-3491 (801) 399-4905 (435) 752-8272

WEBER COUNTY COMMISSION ACCEPTANCE

This is to Certify that this Subdivision Plat, the Dedication of Streets and other Public Ways and Financial Guarantee of Public Improvements Associated with this Subdivision, Thereon are Hereby Approved and Accepted by the Commissioners of Weber County Utah
 Signed this _____ Day of _____, 2014.

 Chairman, Weber County Commission

Attest

WEBER COUNTY SURVEYOR

I hereby certify that the Weber County Surveyor's Office has Reviewed this Plat for Mathematical Correctness, Section Corner Data, and for Harmony with the Lines and Monuments on Record in County Offices. The Approval of this Plat by the Weber County Surveyor does not Relieve the Licensed Land Surveyor who Executed this Plat from the Responsibilities and/or Liabilities Associated Therewith. Signed this _____ Day of _____, 2014.

 Weber County Surveyor

WEBER COUNTY ATTORNEY

I have Examined the Financial Guarantee and Other Documents Associated with this Subdivision Plat, and in my Opinion they Conform with the County Ordinance Applicable Thereto and now in Force and Affect
 Signed this _____ Day of _____, 2014.

 Weber County Attorney

Note:
 Due to the topography and the location of this subdivision all owners will accept responsibility for any storm water runoff from the road adjacent to this property until curb & gutter is installed.

