

Reeve & Associates, Inc.
920 CHAMBERS STREET, SUITE 14, OGDEN, UTAH 84403
TEL: (801) 621-3100 FAX: (801) 621-2666 www.reeve-assoc.com
LAND PLANNERS • CIVIL ENGINEERS • LAND SURVEYORS
TRAFFIC ENGINEERS • STRUCTURAL ENGINEERS • LANDSCAPE ARCHITECTS

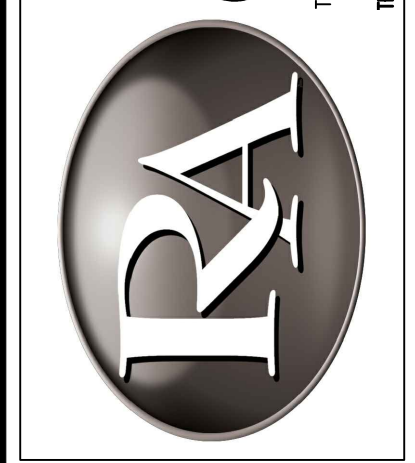

REVISIONS	DATE	DESCRIPTION
1	12-15-15	RH County Comments
2	1-11-15	RH County Comments
3	1-17-15	TP Client Changes
4	2-27-15	TP County Comments
5	3-27-15	RH County Comments
6	6-25-15	RH County Comments
7	7-22-15	RH County Comments

Construction Notes:

- ALL CONSTRUCTION IS TO CONFORM TO THE STANDARD DRAWINGS AND SPECIFICATIONS OF WEBER COUNTY.
- CULINARY WATER**
W/10 - 10" PVC C-900 CLASS 200 WATER
- STORM DRAIN**
SD/15 - 15" RCP STORM DRAIN
SD/15 ARCH - 15" ARCH RCP STORM DRAIN
- SANITARY SEWER**
SS/8 - 8" PVC C-900 SEWER LINE
SS/12 - 12" PVC C-900 SEWER LINE
- SECONDARY WATER**
SW/8 - 8" PVC C-900 SECONDARY WATER LINE
- LAND DRAIN**
LD/8 - 8" PEFORATED PVC C-900 LAND DRAIN WRAPPED IN FABRIC

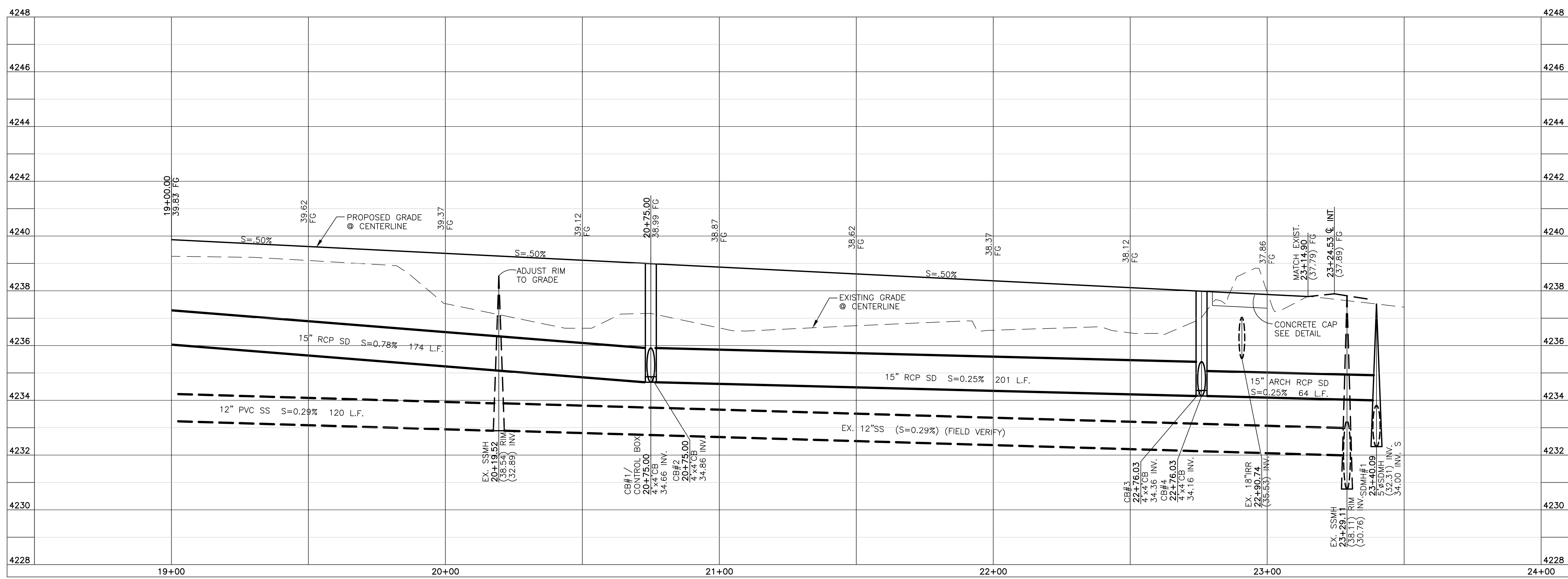
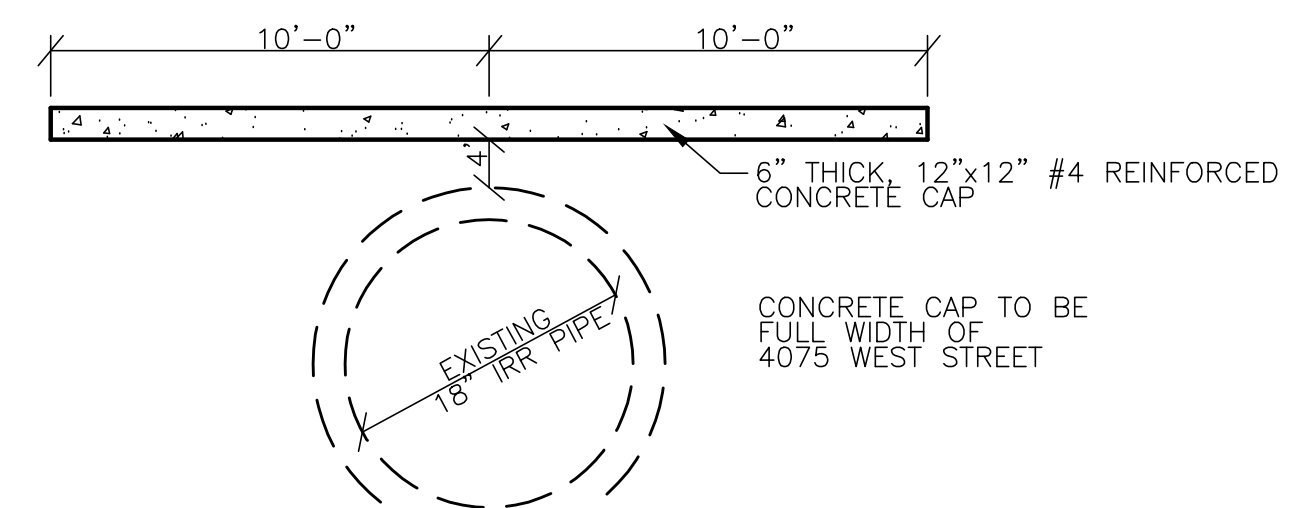
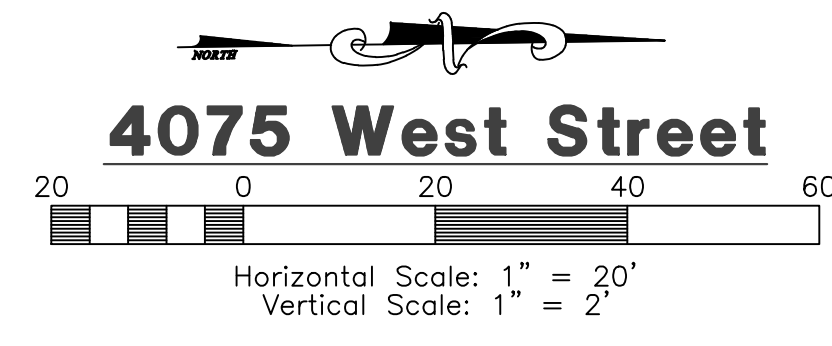
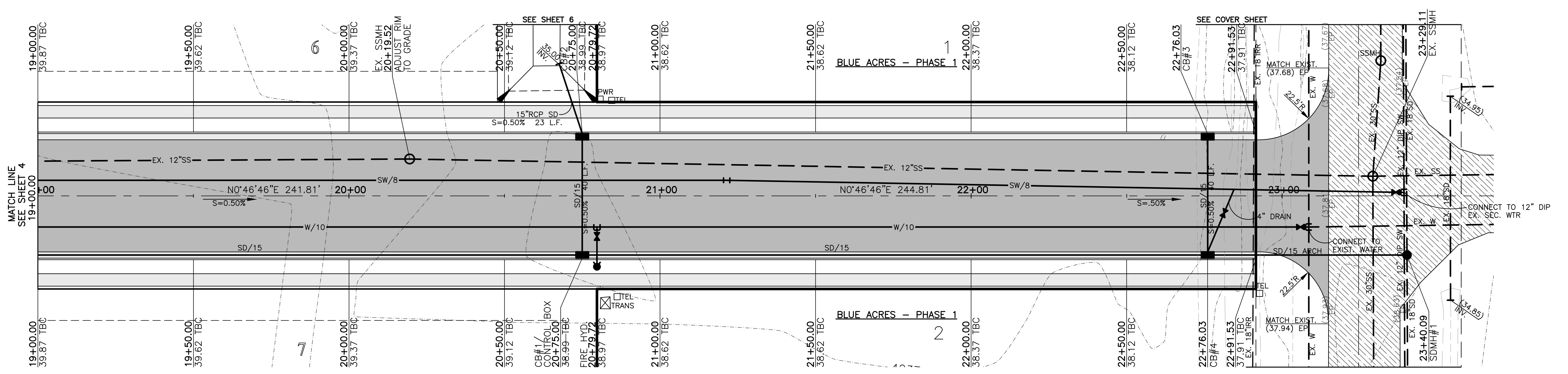

Blue Stakes Location Center
Call: Toll Free 1-800-662-4111
Two Working Days Before You Dig

Revised: 7-22-15

Blue Acres Subdivision Phase-4
WEBER COUNTY, UTAH
4075 West Street
19+00.00 - 23+50.00



Project Info.
Engineer: J. NATE REEVE, P.E.
Drafted: R. HANSEN
Begin Date: JUNE 10, 2014
Name: BLUE ACRES SUBDIVISION PHASE-4
Number: 5036-01

Sheet **3** of **8** Sheets