

ROPER BUILDINGS

CLARKE FARM LLC

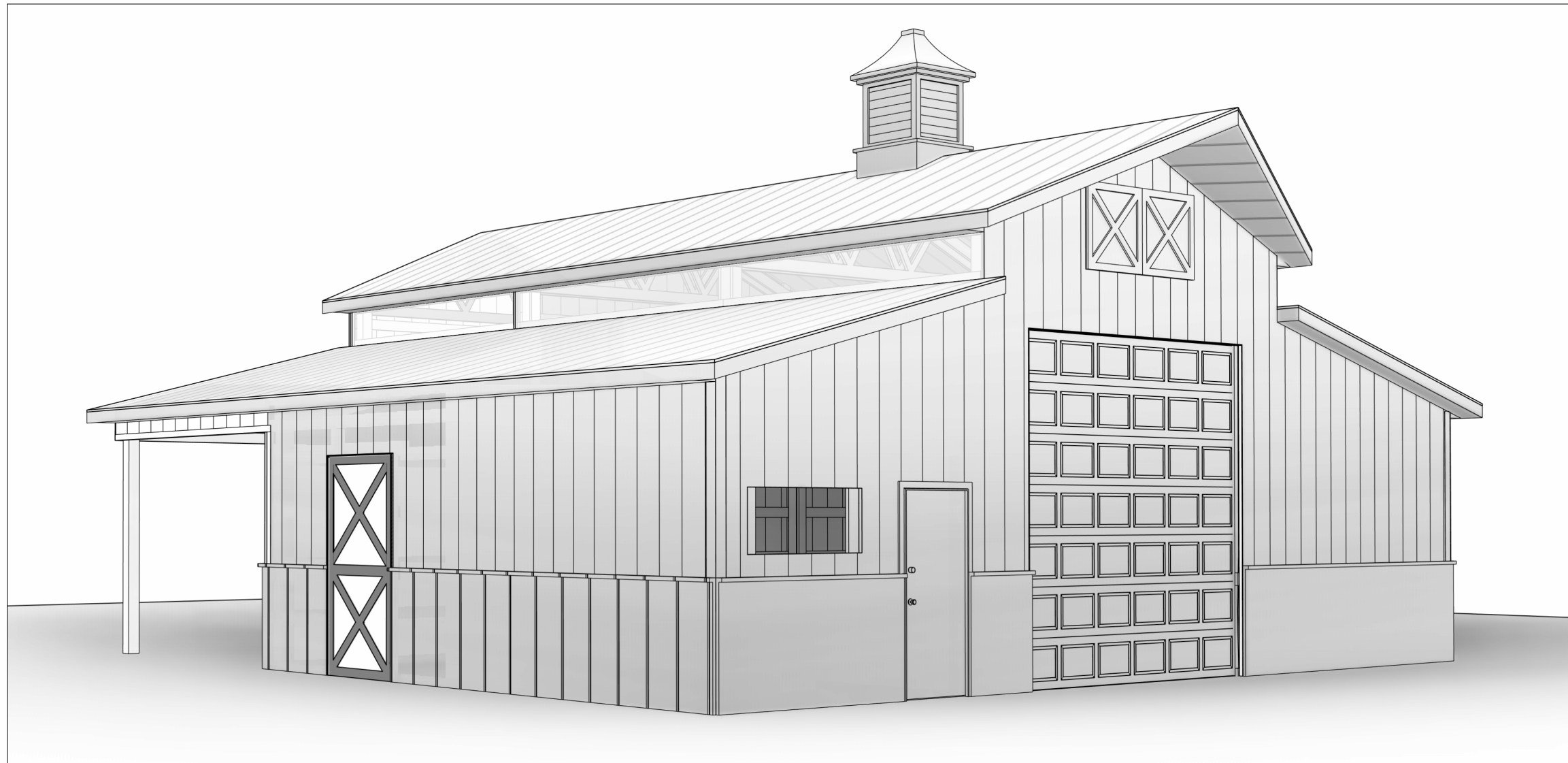

DRAWING INDEX

A0	Title Page
A1	Foundation Plan
A2	Floor Plan
A3	Framing Plan
A4	Roof Plan
A5	Elevations
A6	Panel Layouts
A6.1	OSB Layouts
A7	Details
A8	Details
A9	Engineering Notes

CONTACTS

CONTRACTOR:

DMLP RESOURCES/
ROPER BUILDINGS
PHONE: (801) 689-3630

ENGINEERING:

WHITE PINE ENGINEERING
PHONE: (435) 515-0126

BUILDING INFORMATION

BUILDING INFORMATION:

DIMENSIONS: 16' x 24' = 384 Sq. Ft
LEAN: (2)12' x 24' & 40' x 12' = 1,056 Sq. Ft.
TOTAL SQUARE FOOTAGE: 1,440 Sq. Ft.

SITE INFORMATION:

USE: AGRICULTURE
ADDRESS:
4627 East 2650 North Clarke Lane
Eden, UT 84310

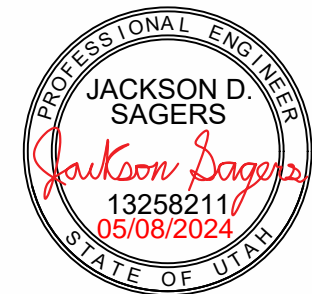

DATE:

5/7/2024

PIERS			
Count	Type	Diameter	Depth
14	F24	2' - 0"	3' - 4"
4	F30	2' - 6"	3' - 4"

**DMLP RESOURCES/
ROPER BUILDINGS**
(801) 689-3630

CLARKE FARM LLC
4627 East 2650 North Clarke Lane
Eden, UT 84310

Date: 5/7/2024
Scale: 3/16" = 1'-0"
Drawn by: CBC
Job: CLARKE
Foundation Plan

A1

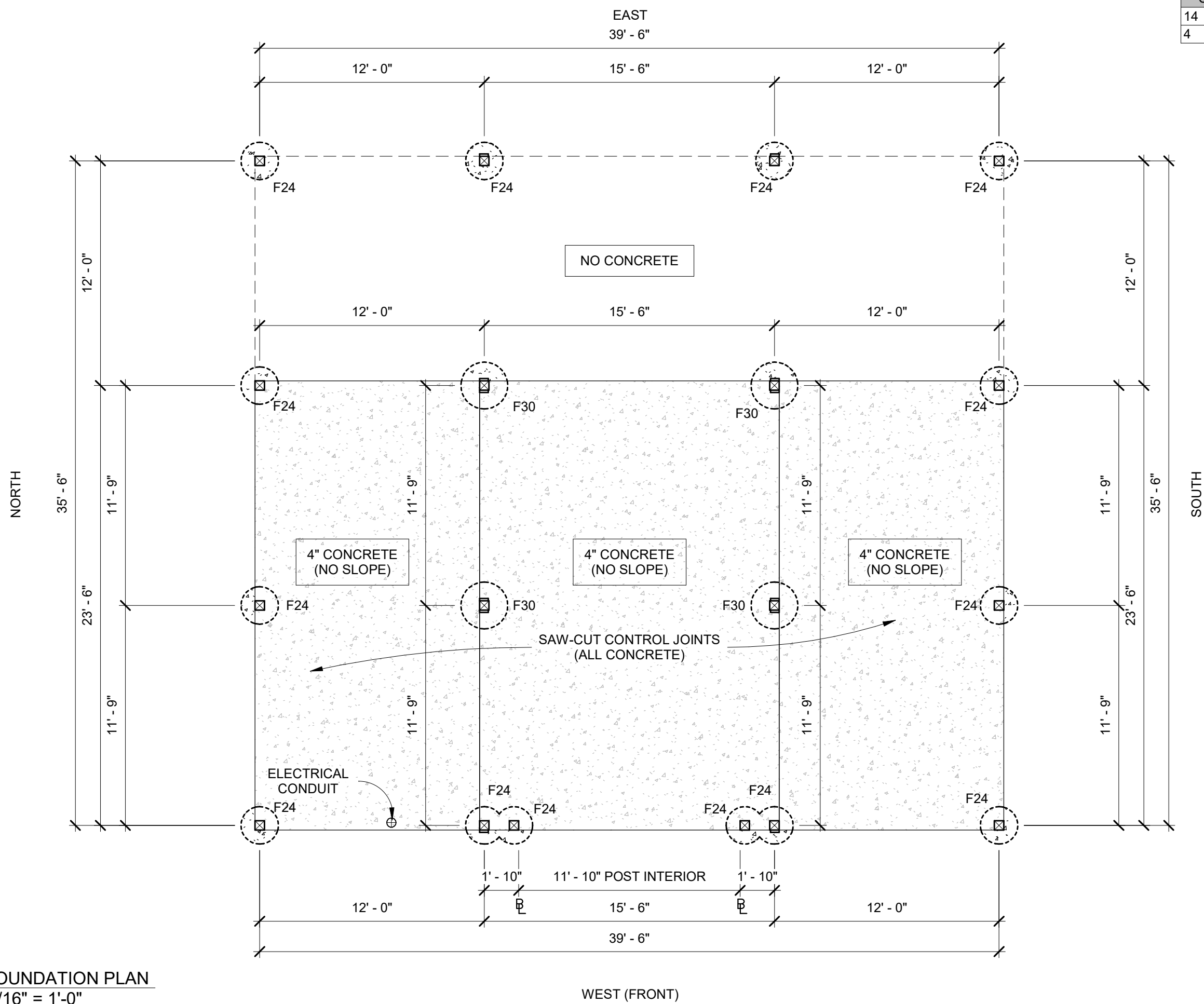
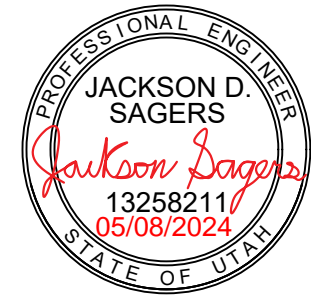

FOUNDATION PLAN
3/16" = 1'-0"

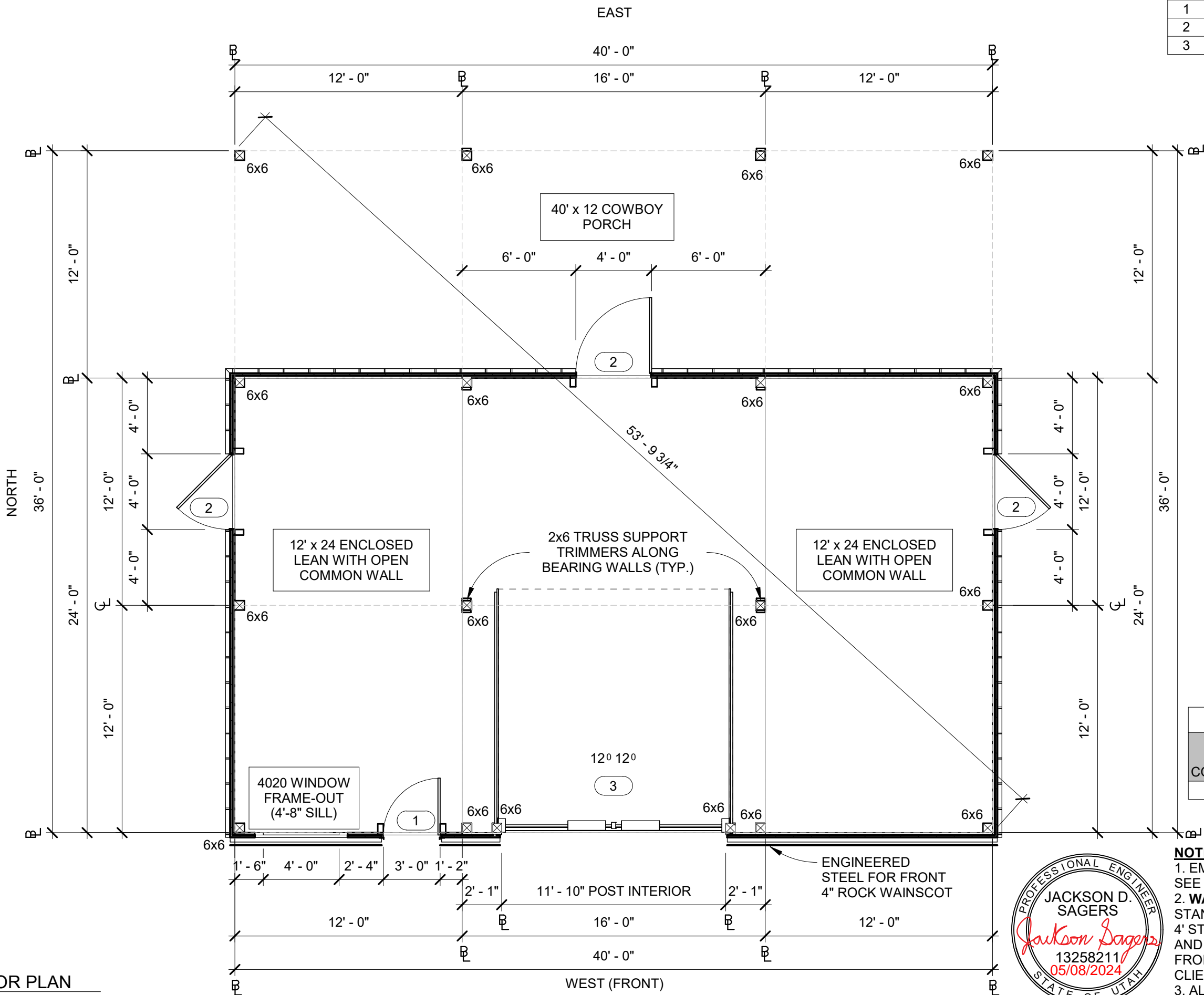

DOORS				
Mark	Count	Description	Width	Height
1	1	MD	3' - 0"	6' - 8"
2	3	DUTCH MD	4' - 0"	8' - 0"
3	1	INSULATED OHD	12' - 0"	12' - 0"

INSULATION		
ROOF	WALLS	ROLLS
FELT	NONE	-

POSTS			
COUNT	SAWN	LAMINATE D TRIAD OPTION	TITAN TIMBER OPTION
18	6x6 HF #1	4-PLY 2x6	3-PLY 2x6

NOTES:
 1. EMBED POST INTO CONCRETE PIER. SEE DETAIL ON SHEET A7.
 2. **WALLS:** STANDARD GIRTS, 29 GA. STEEL PANEL. 4" STEEL WAINSCOT ON NORTH, SOUTH, AND EAST EXTERIOR WALLS. 4" OSB ON FRONT (WEST) TO SUPPORT FUTURE CLIENT PROVIDED ROCK.
 3. ALL POSTS ARE TREATED HF #1 UNLESS OTHERWISE SPECIFIED.

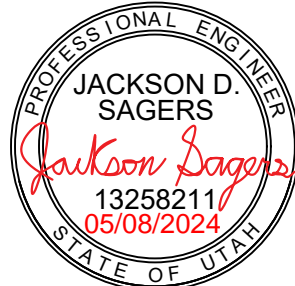

FLOOR PLAN
 3/16" = 1'-0"

DMLP RESOURCES/
 ROPER BUILDINGS
 (801) 689-3630

CLARKE FARM LLC
 4627 East 2650 North Clarke Lane
 Eden, UT 84310

Date: 5/7/2024
 Scale: 3/16" = 1'-0"
 Drawn by: CBC
 Job: CLARKE
 Floor Plan
A2

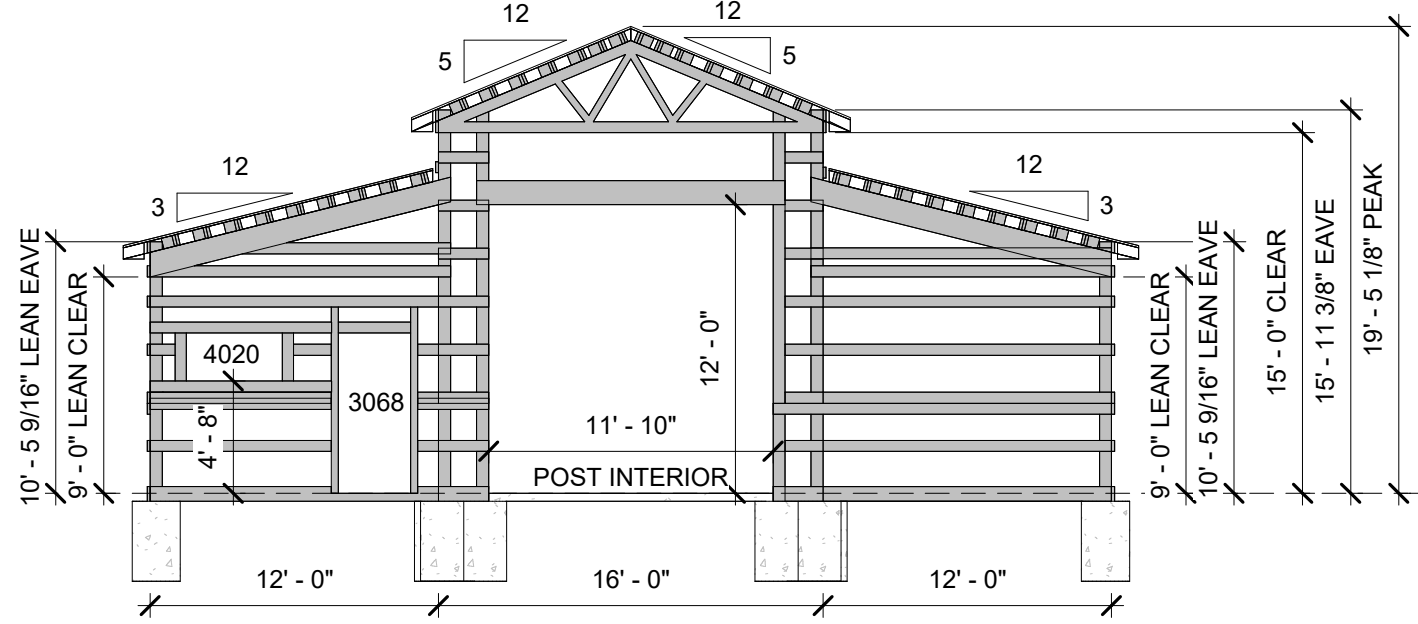

1 WEST GIRT
1/8" = 1'-0"

PURLINS NOT SHOWN ON EAVE VIEWS FOR CLARITY

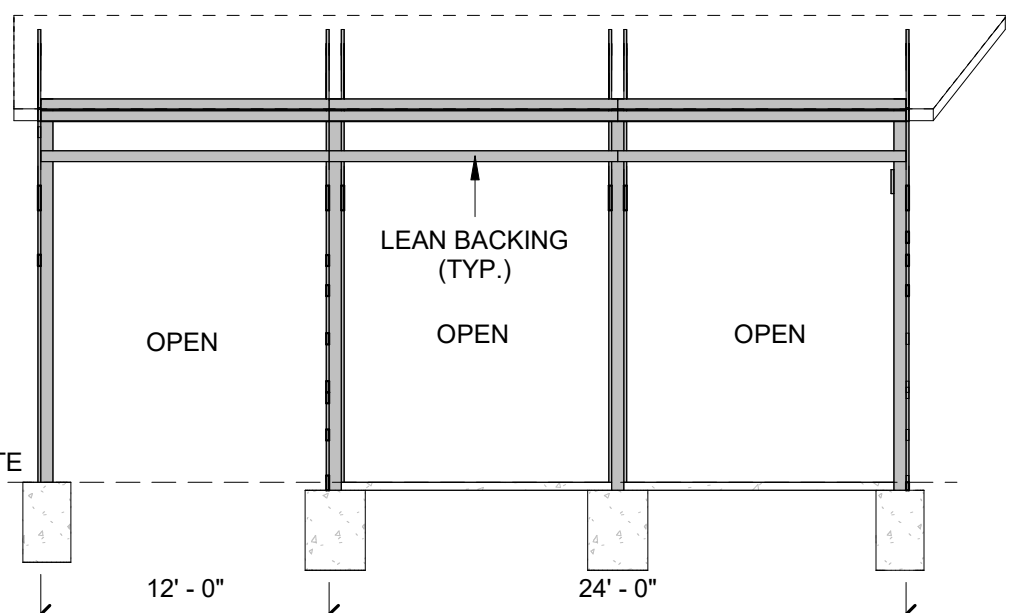

2 NORTH GIRT
1/8" = 1'-0"

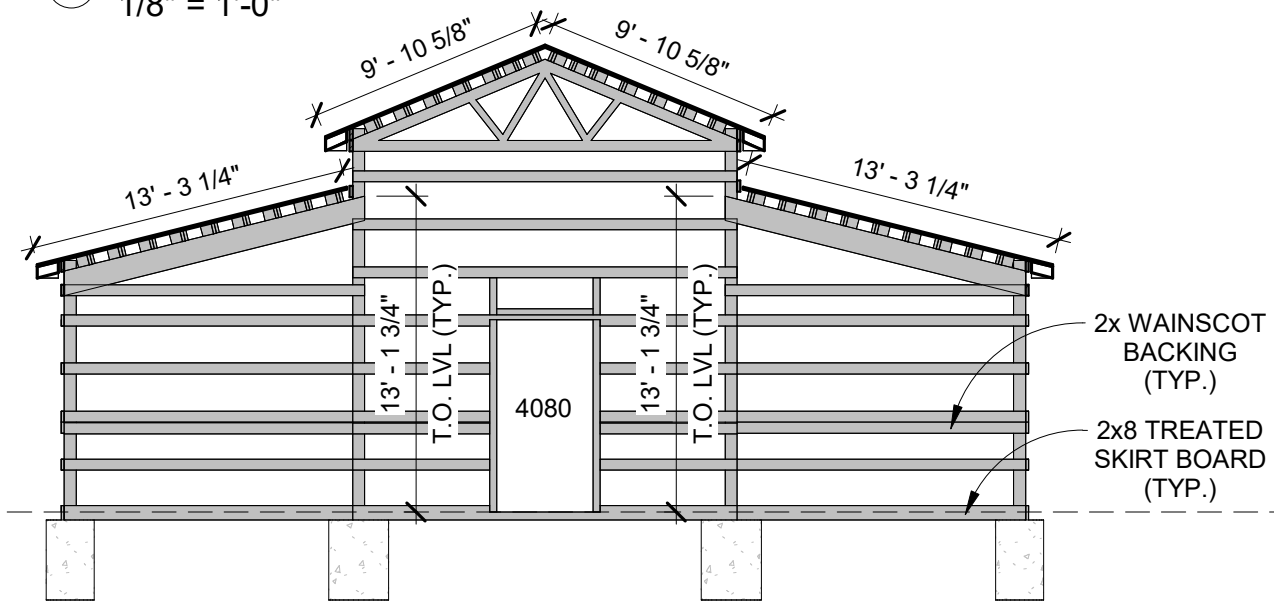

3 EAST GIRT
1/8" = 1'-0"

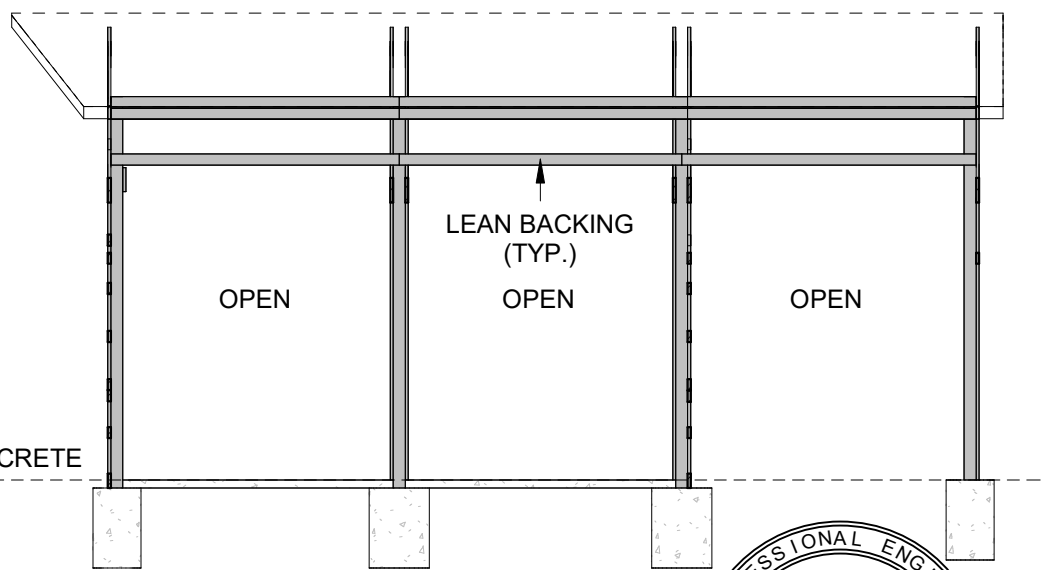

4 SOUTH GIRT
1/8" = 1'-0"

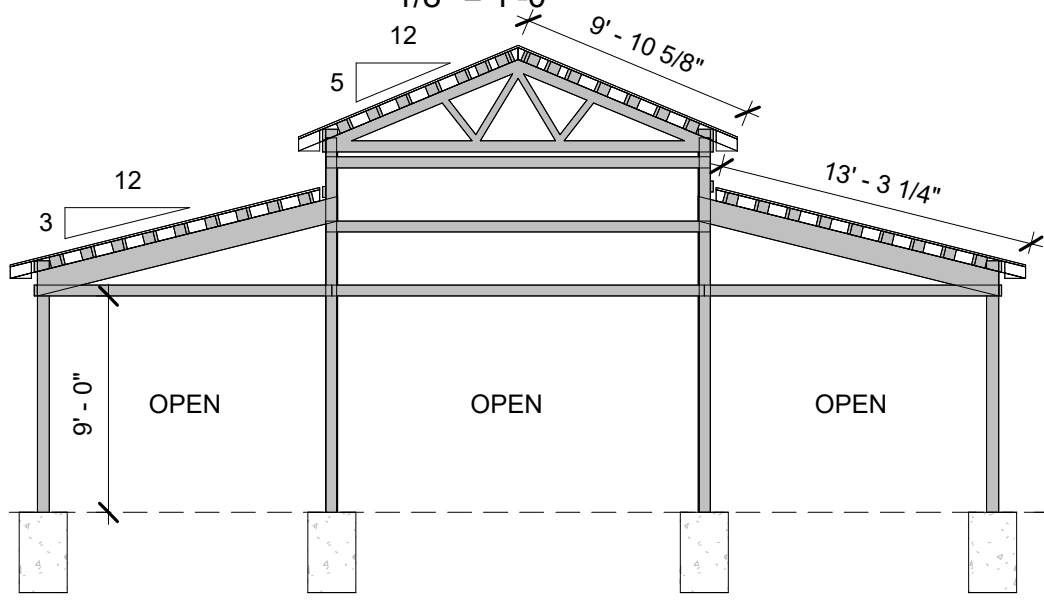
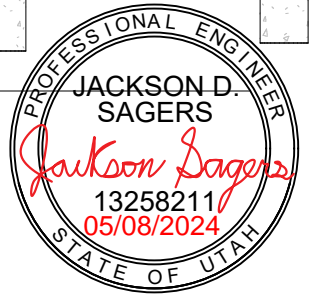

5 EAST GIRT (LEAN)
1/8" = 1'-0"

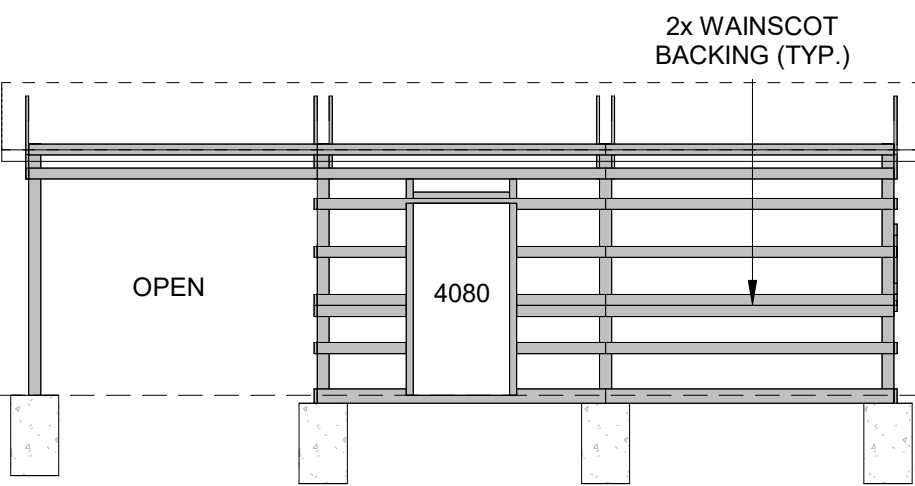

6 NORTH GIRT (LEAN)
1/8" = 1'-0"

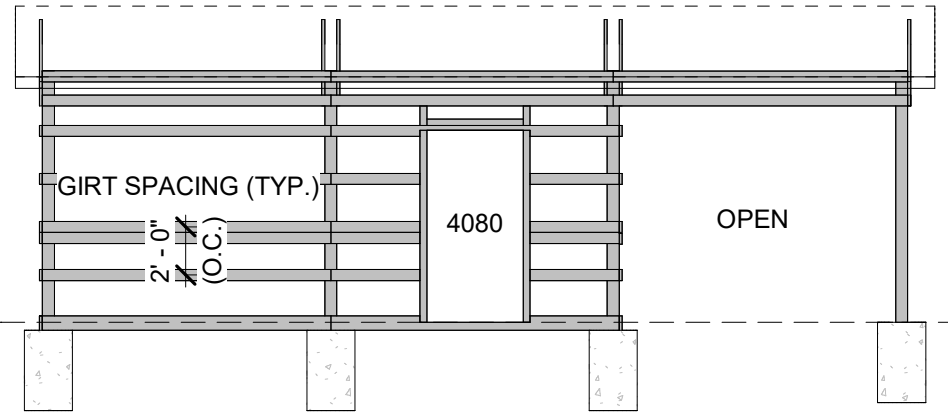

7 SOUTH GIRT (LEAN)
1/8" = 1'-0"

DMLP RESOURCES/
ROPER BUILDINGS
(801) 689-3630

CLARKE FARM LLC
4627 East 2650 North Clarke Lane
Eden, UT 84310

Date: 5/7/2024
Scale: 1/8" = 1'-0"
Drawn by: CBC
Job: CLARKE
Framing Plan

A3

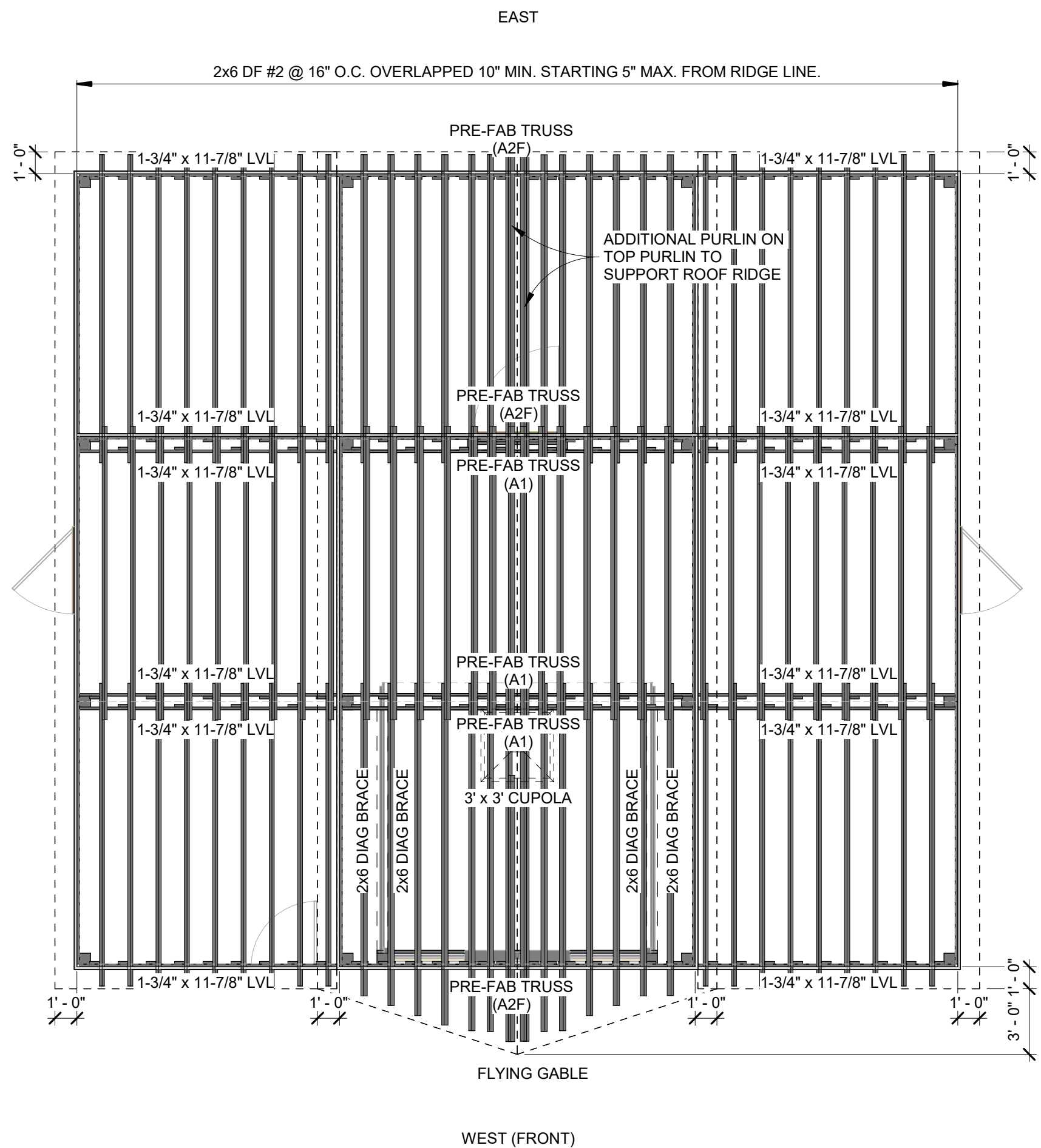

ROOF FRAMING NOTES:

ROOF PITCHES:
MAIN: 5/12
(2) LEANS: 3/12 (RAISED)

PURLINS:
2x6 DF #2 AT 16" ON CENTER OVERLAPPED 10" MIN.
STARTING 5" MAX. FROM RIDGE LINE.

ADDITIONAL PURLIN ON TOP PURLIN TO SUPPORT
ROOF RIDGE

OVERHANGS:
12" ON ALL PERIMETERS
12" + 36" OFFSET ON WEST (FRONT) FOR FLYING
GABLE

ROOF INSULATION:
FELT

FLYING GABLE:
3' x 3' FLYING GABLE 10' FROM FRONT (14' FROM
FRONT OF FLYING GABLE) OF MAIN WITH BACKING
AS NEEDED.

OSB:
OSB UNDER METAL ON (2) LEAN ROOFS



Roof Plan
3/16" = 1'-0"

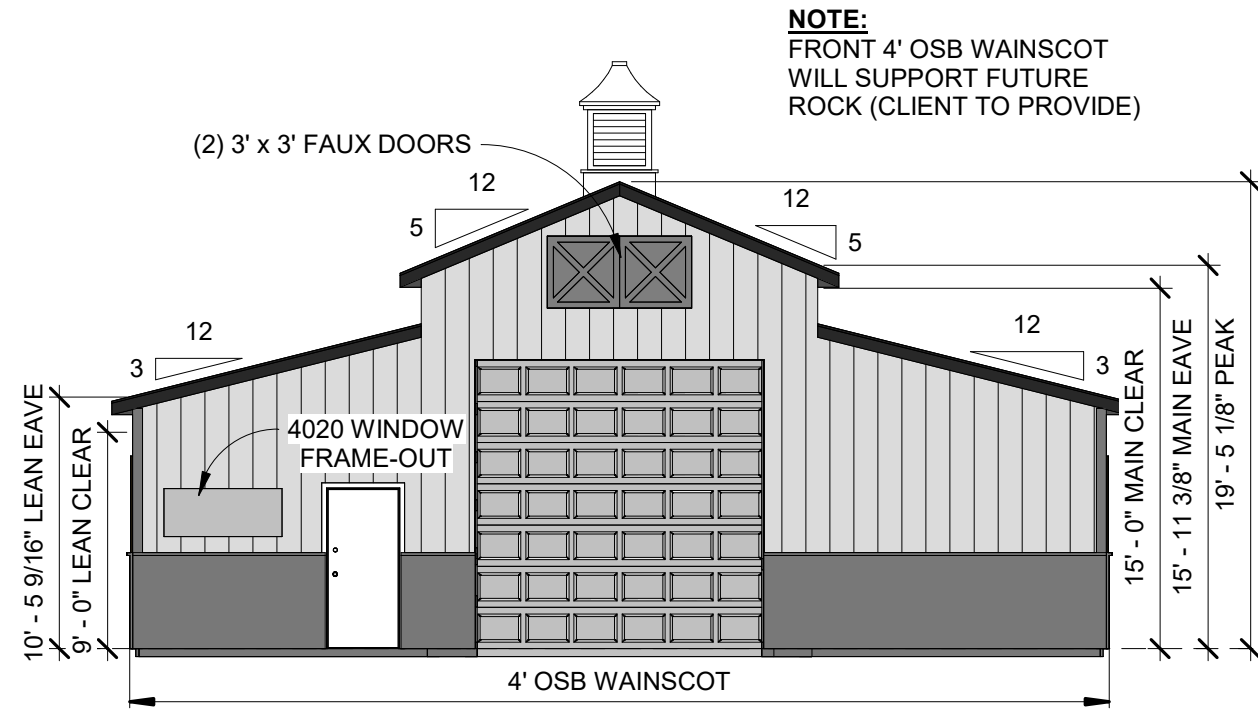

NOTE:
FRONT 4' OSB WAINSCOT
WILL SUPPORT FUTURE
ROCK (CLIENT TO PROVIDE)

1 WEST (FRONT) ELEVATION
1/8" = 1'-0"

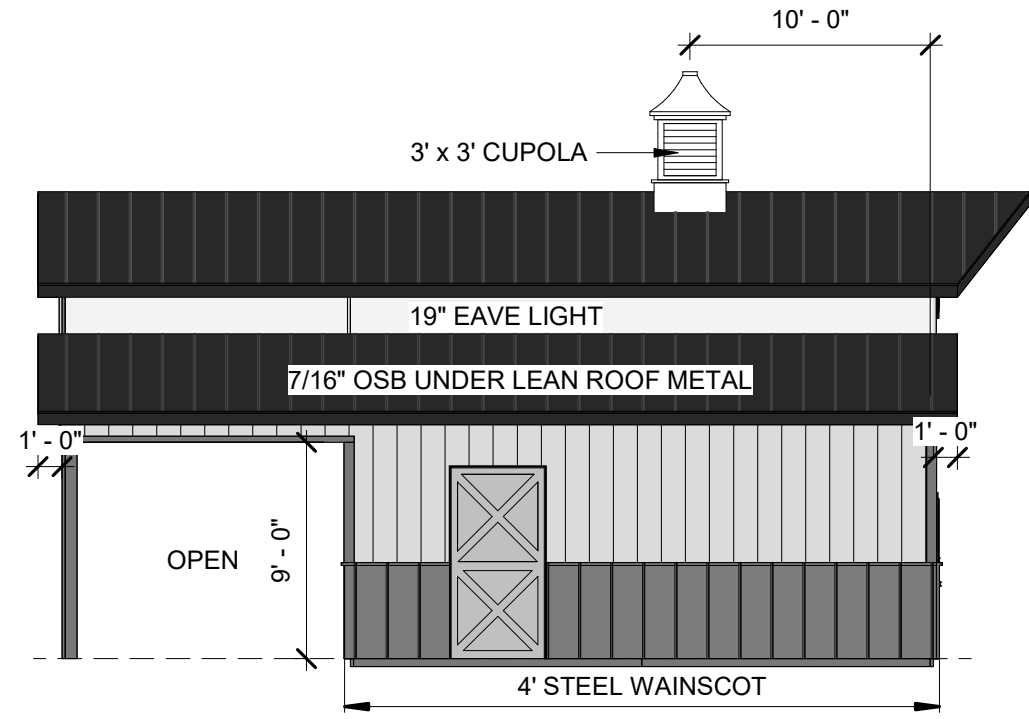

2 NORTH ELEVATION
1/8" = 1'-0"

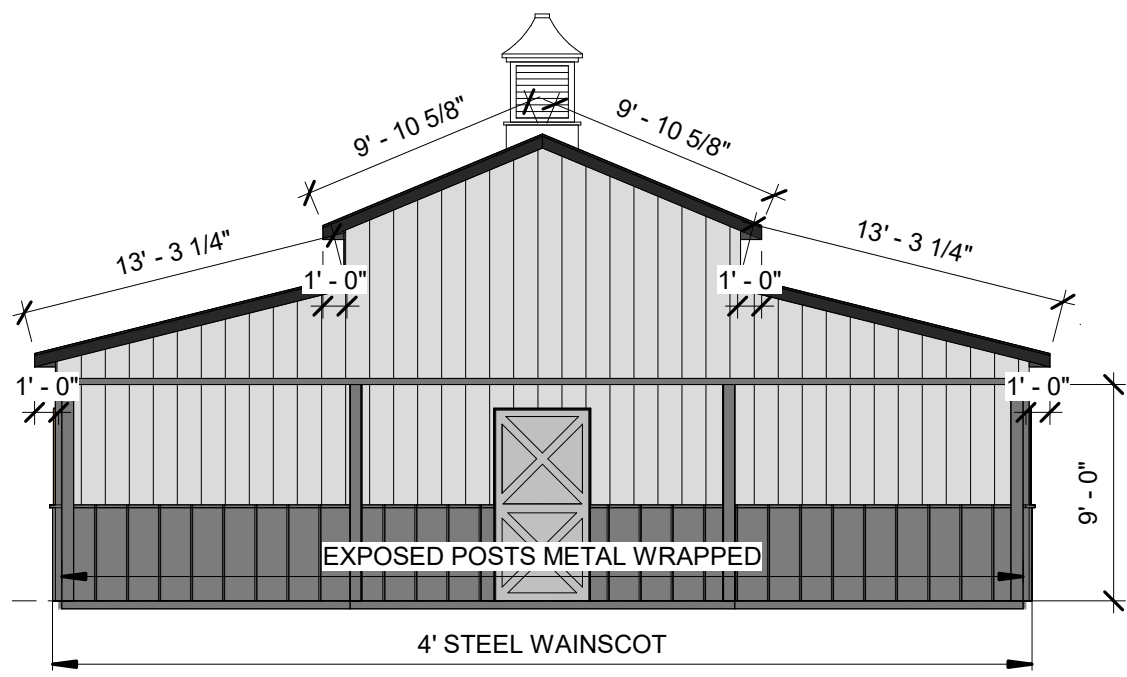

3 EAST ELEVATION
1/8" = 1'-0"

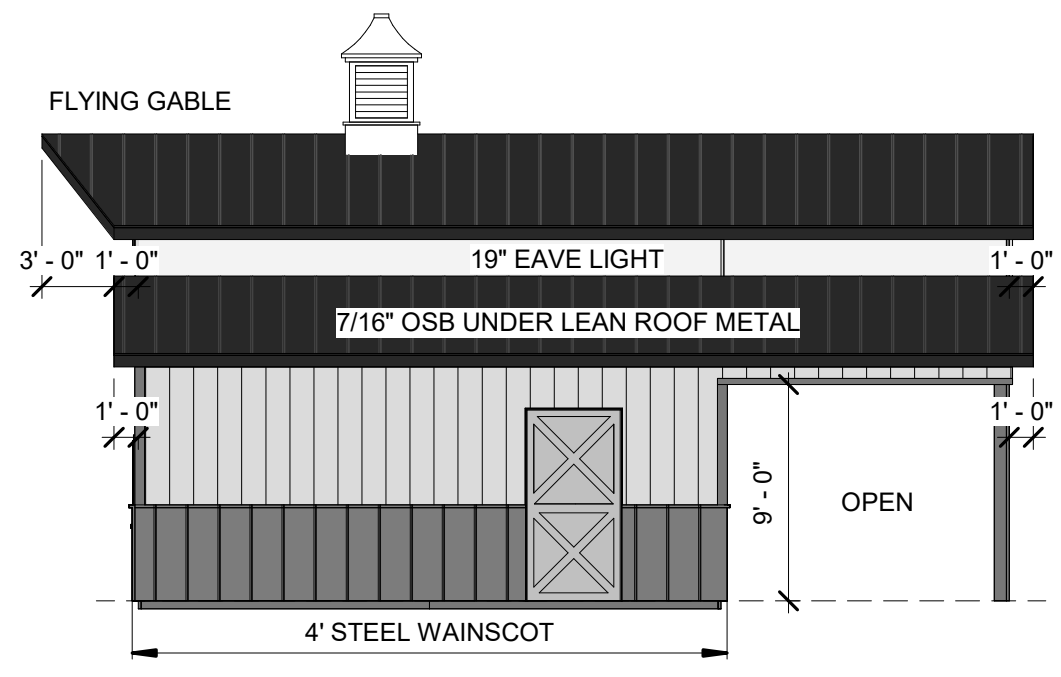

4 SOUTH ELEVATION
1/8" = 1'-0"

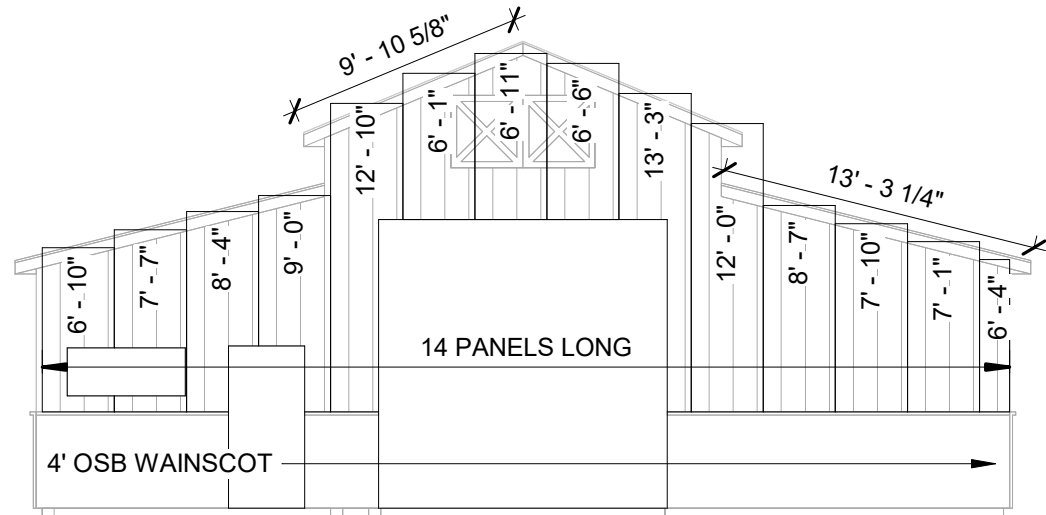

1 WEST PANEL
1/8" = 1'-0"

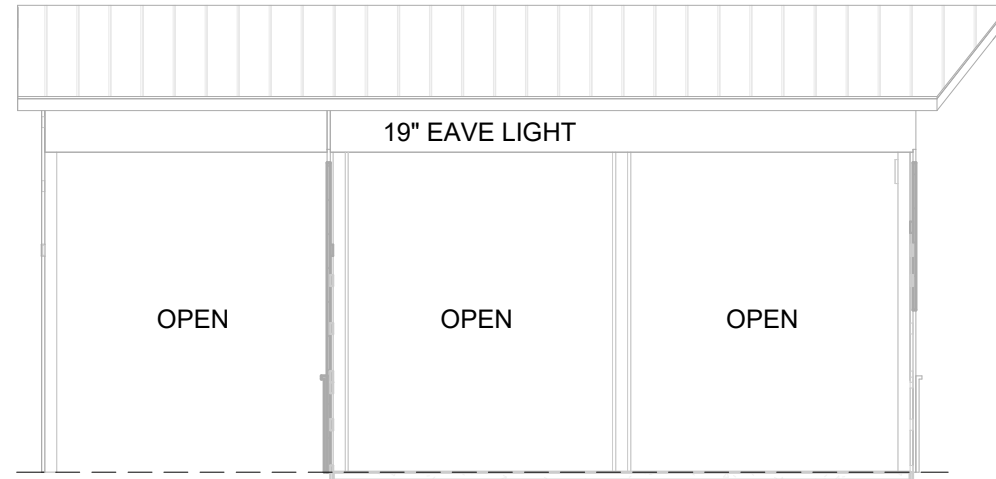

2 NORTH PANEL
1/8" = 1'-0"

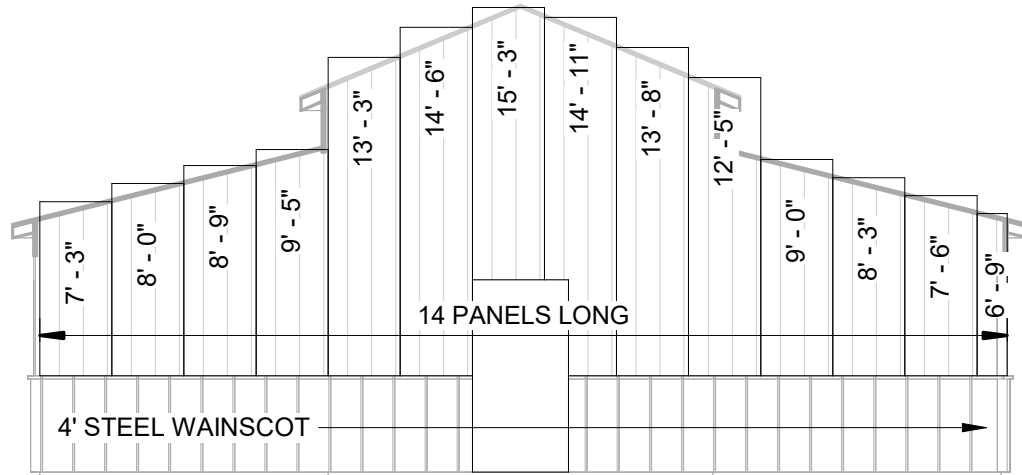

3 EAST PANEL
1/8" = 1'-0"

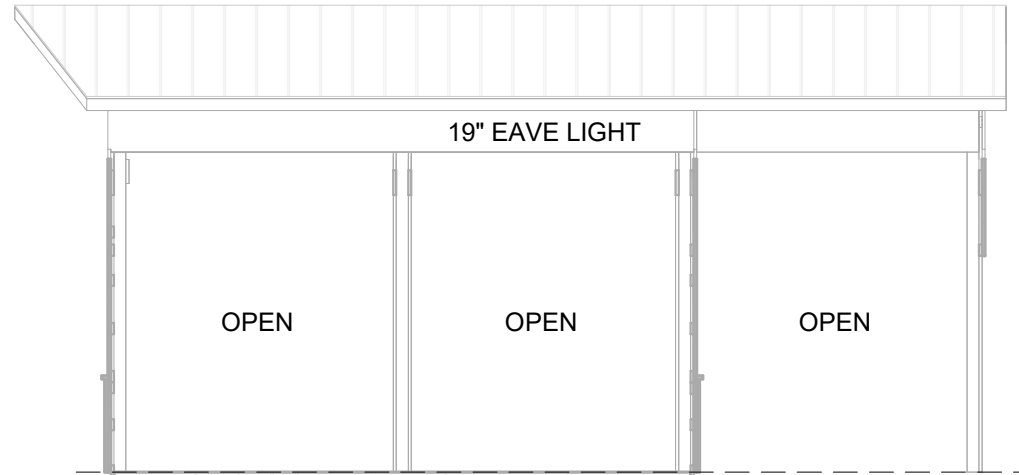

4 SOUTH PANEL
1/8" = 1'-0"

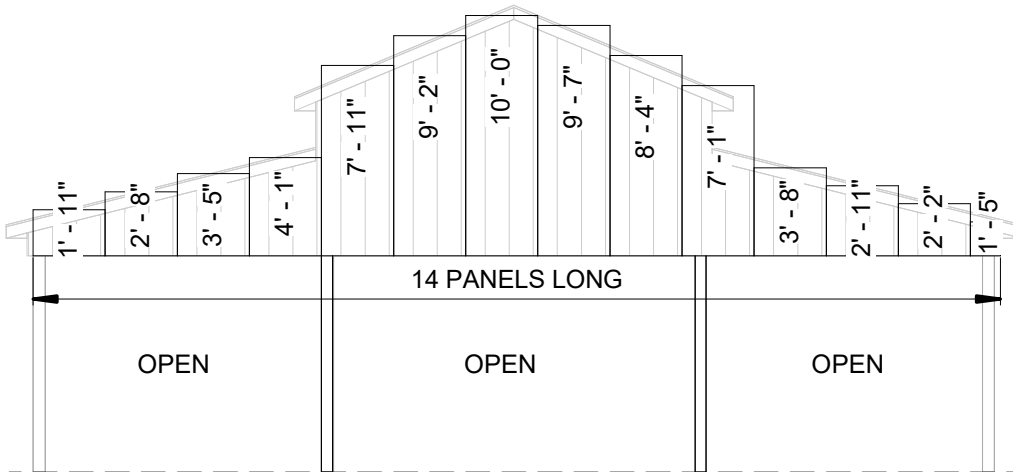

5 EAST PANEL (LEAN)
1/8" = 1'-0"

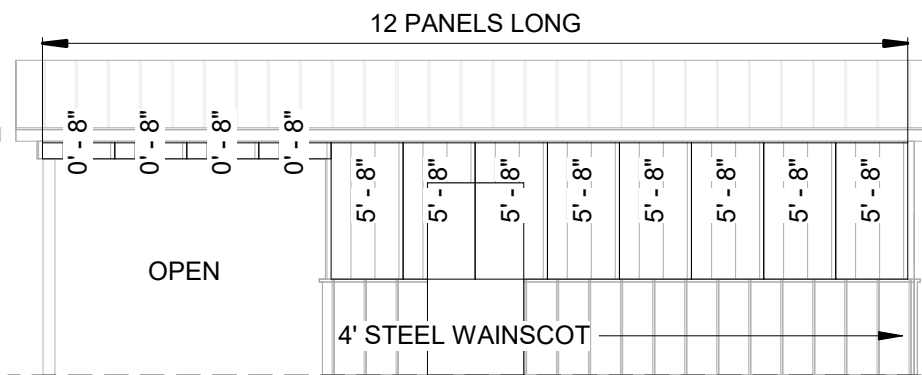

6 NORTH PANEL (LEAN)
1/8" = 1'-0"

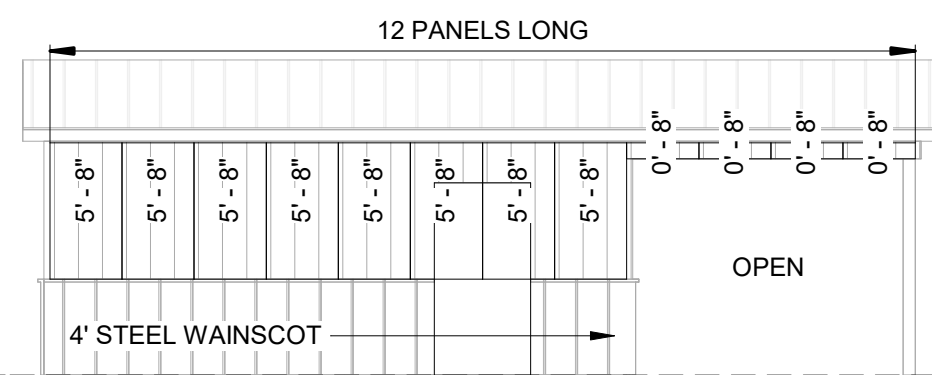

7 SOUTH PANEL (LEAN)
1/8" = 1'-0"

PANEL SCHEDULE	
Panel Height	Count
8"	8
1' - 5"	1
1' - 11"	1
2' - 2"	1
2' - 8"	1
2' - 11"	1
3' - 5"	1
3' - 8"	1
4' - 1"	1
5' - 8"	16
6' - 1"	1
6' - 4"	1
6' - 6"	1
6' - 9"	1
6' - 10"	1
6' - 11"	1
7' - 1"	2
7' - 3"	1
7' - 6"	1
7' - 7"	1
7' - 10"	1
7' - 11"	1
8' - 0"	1
8' - 3"	1
8' - 4"	2
8' - 7"	1
8' - 9"	1
9' - 0"	2
9' - 2"	1
9' - 5"	1
9' - 7"	1
10' - 0"	1
12' - 0"	1
12' - 5"	1
12' - 10"	1
13' - 3"	2
13' - 8"	1
14' - 6"	1
14' - 11"	1
15' - 3"	1
Grand total:	66

DMLP RESOURCES/
ROPER BUILDINGS
(801) 689-3630

CLARKE FARM LLC
4627 East 2650 North Clarke Lane
Eden, UT 84310

Date: 5/7/2024
Scale: 1/8" = 1'-0"
Drawn by: CBC
Job: CLARKE
Panel Layouts

ROOF PLAN OSB
3/16" = 1'-0"

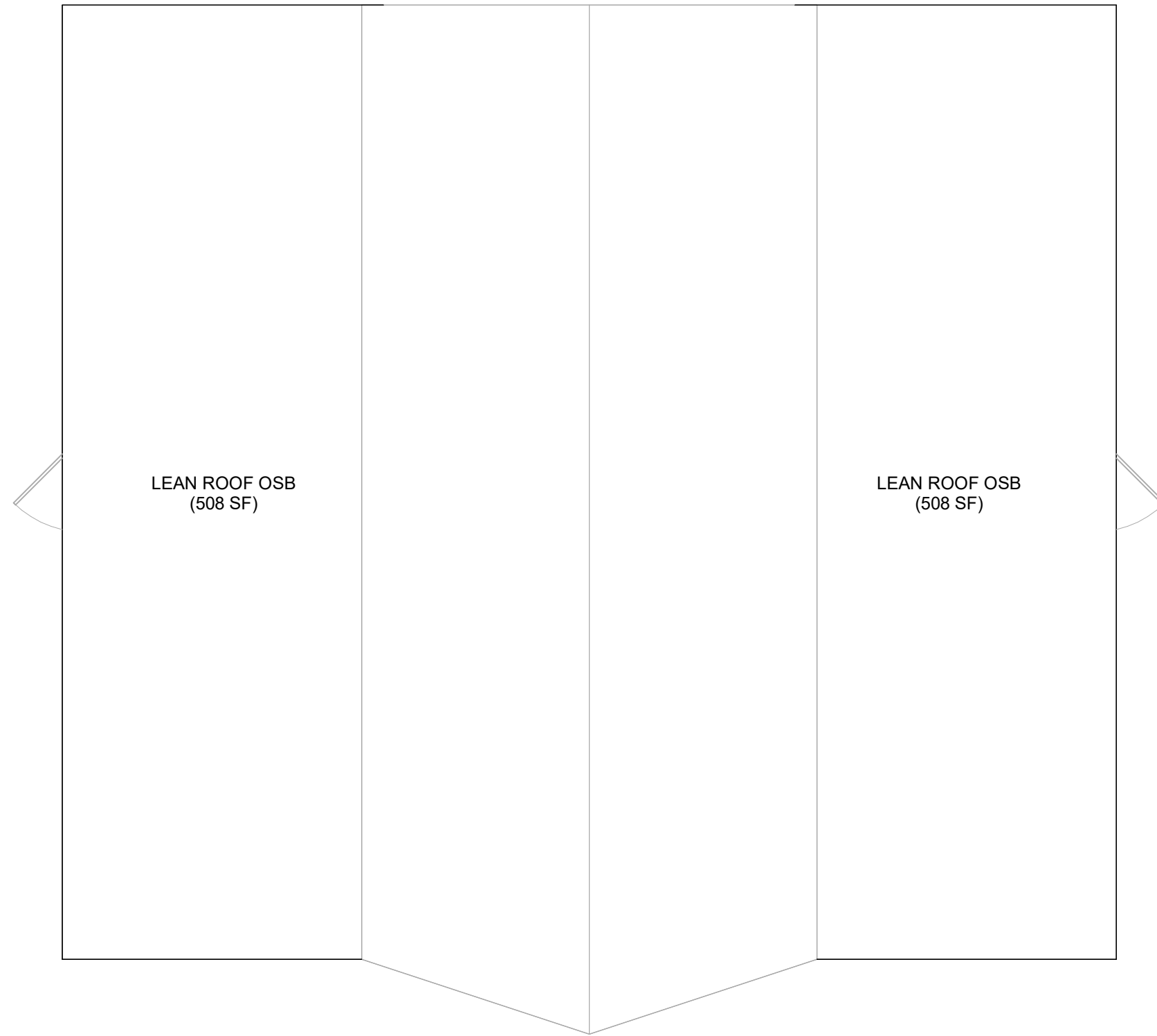

OSB TABLE

ROOF OSB: 1,016 SF

TOTAL OSB: 1,016 SF

Date: 5/7/2024

Scale: 3/16" = 1'-0"

Drawn by: CBC

Job: CLARKE

OSB Layouts

A6.1

CLARKE FARM LLC

4627 East 2650 North Clarke Lane
Eden, UT 84310

**DMLP RESOURCES/
ROPER BUILDINGS**
(801) 689-3630

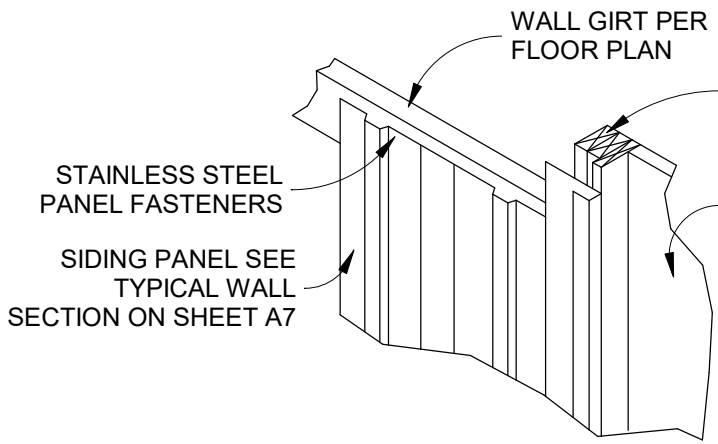

① **MAN DOOR JAMB FLASHING**
N.T.S.

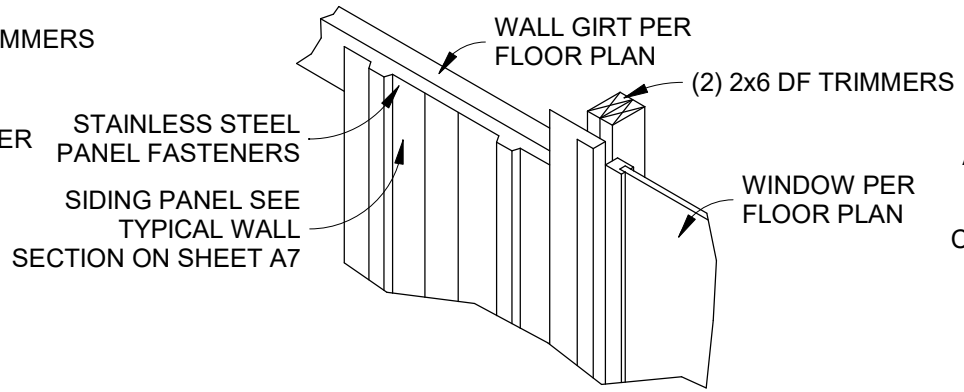

② **WINDOW JAMB FLASHING**
N.T.S.

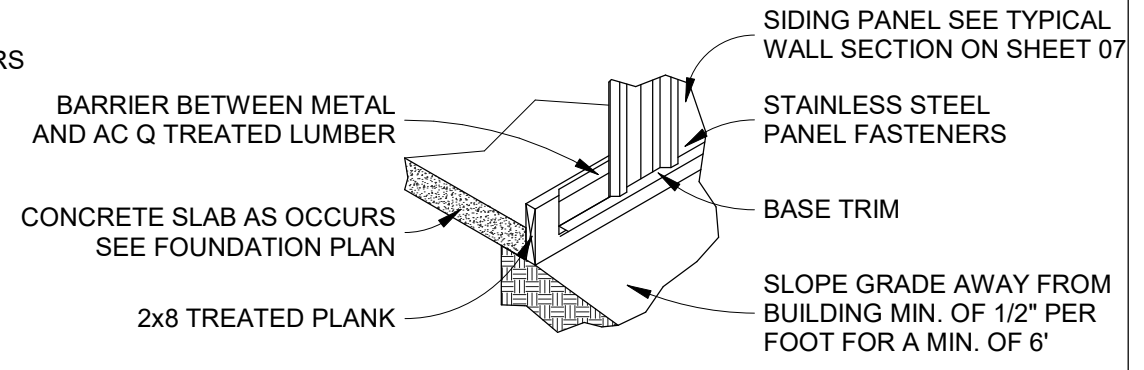

③ **BASE GUARD FLASHING**
N.T.S.

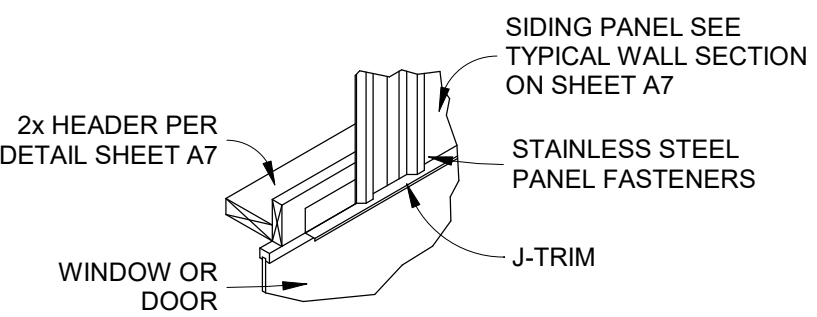

④ **WINDOW/DOOR HEADER FLASHING**
N.T.S.

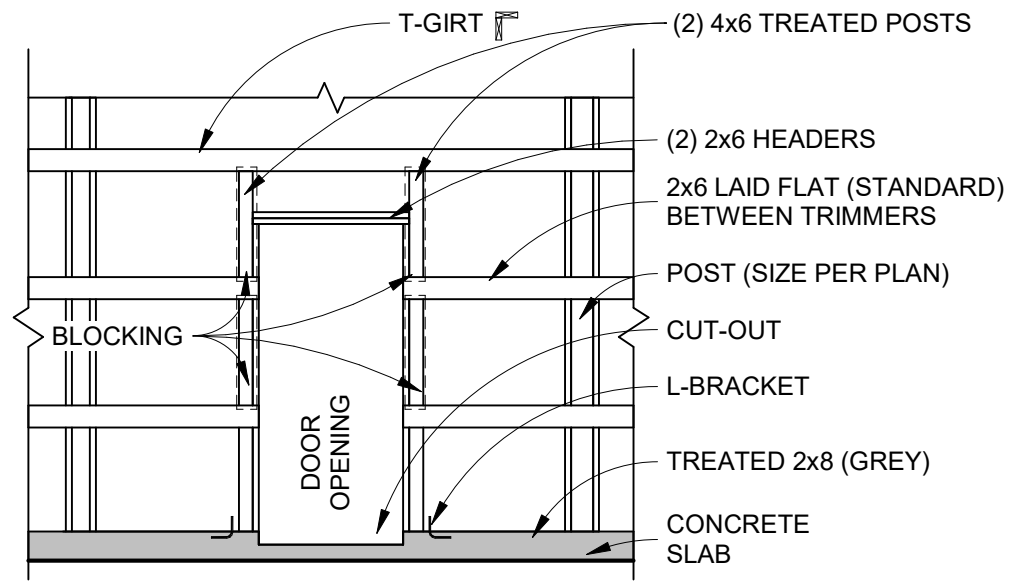

⑤ **MD OPENING**
1/4" = 1'-0"

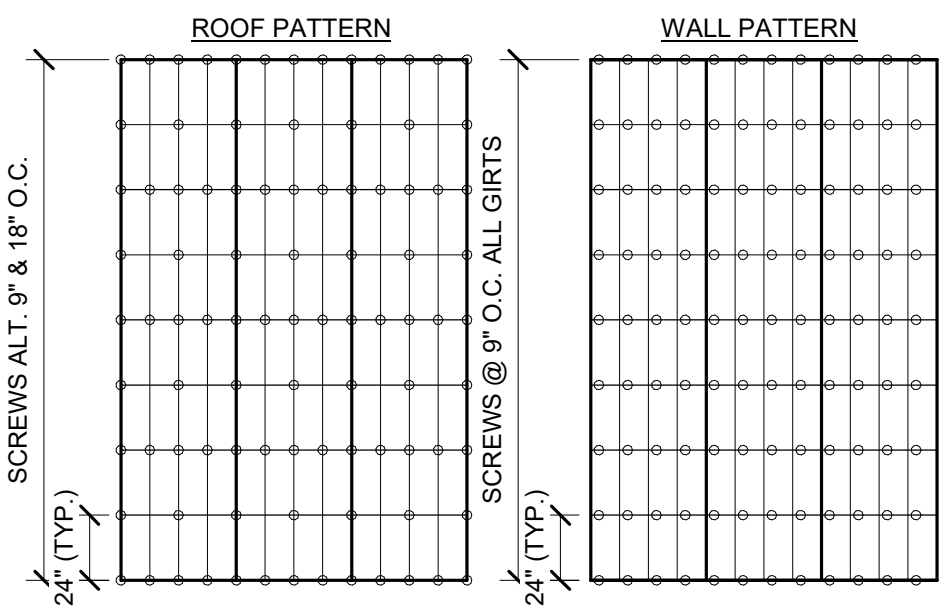
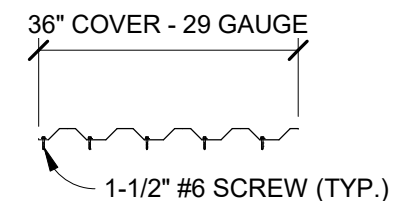
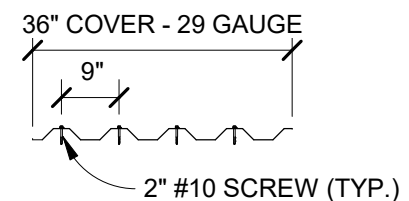

⑦ **ROPER BUILDINGS SCREW PATTERNS**
1" = 10'-0"

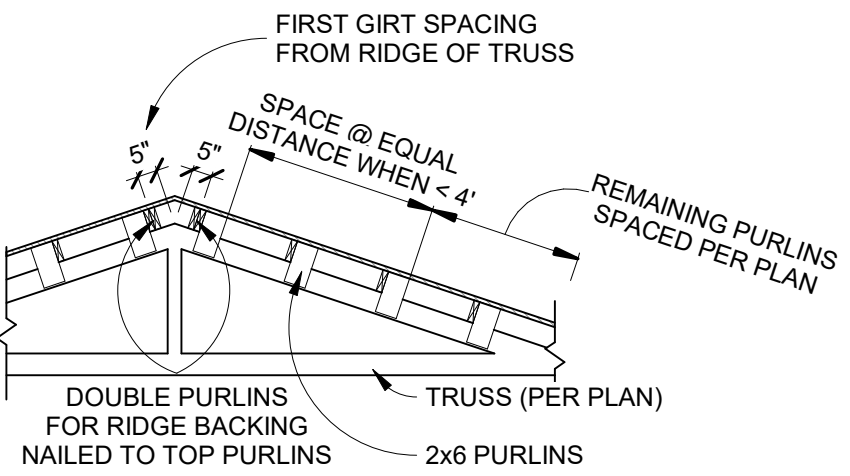

⑥ **T.O. ROOF DETAIL**
1/4" = 1'-0"



ROOF & WALL PANELS: 29 GA. AG PANELS
FABRAL NAME: GRAND RIB 3 - 3' COVER
TRI-STATE NAME: TUFF RIB - 3' COVER

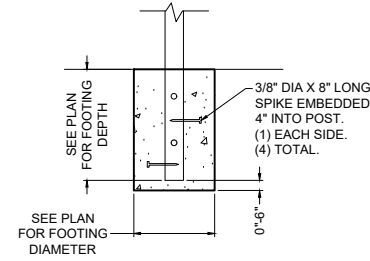

1 24"-30" DIA FOOTING
A8 NTS

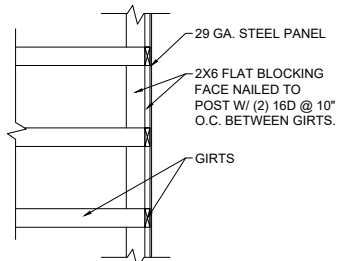

2 CORNER BLOCKING
A8 NTS

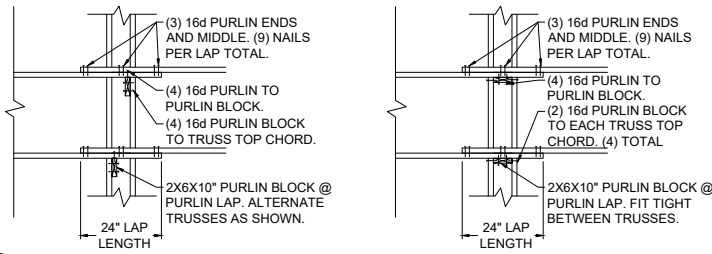

3 PURLIN LAP -OR- PURLIN LAP
A8 NTS

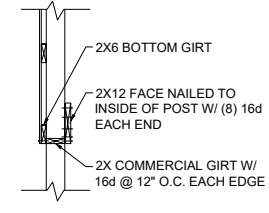

4 NON BEARING GARAGE HDR
A8 NTS

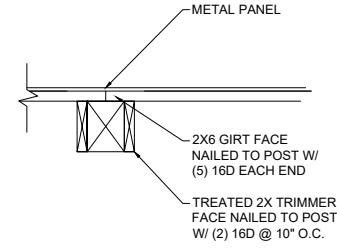

5 SECTION AT POST
A8 NTS

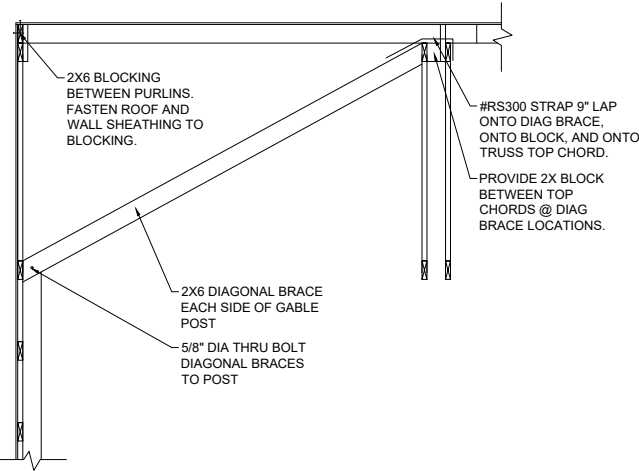

6 DIAGONAL BRACE
A8 NTS

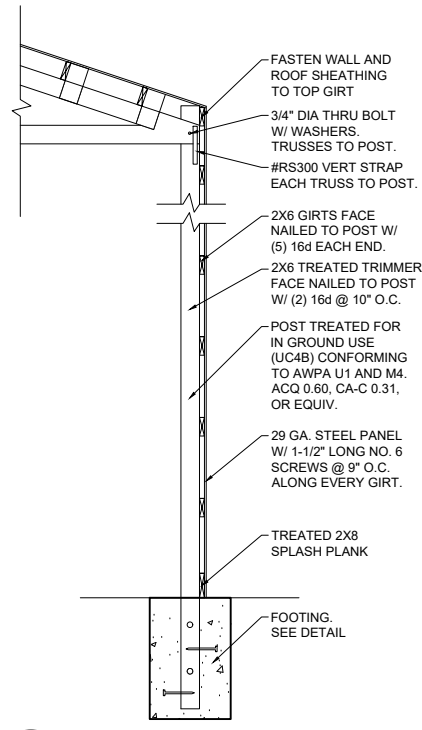

7 WALL SECTION
A8 NTS

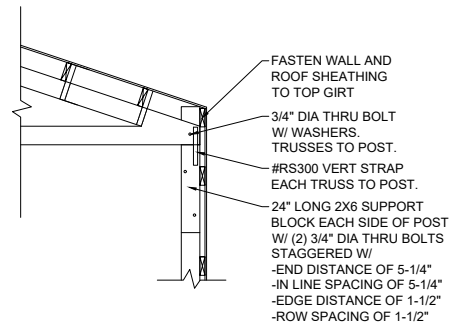

8 3/4" THRU BOLT TRUSS SUPPORT ALTERNATIVE
A8 NTS

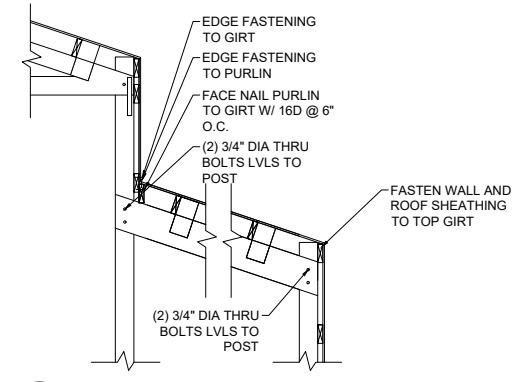

9 OFFSET LEAN SECTION
A8 NTS

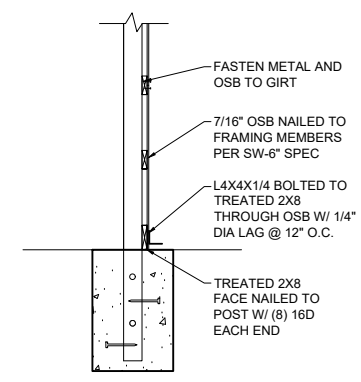

10 MASONRY WAINSCOT SUPPORT
A8 NTS

DMLP RESOURCES/
ROPER BUILDINGS
(801) 689-3630

CLARKE FARM LLC
4627 East 2650 North Clarke Lane
Eden, UT 84310

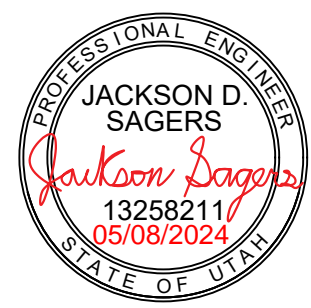

Date: 5/7/2024
Scale:
Drawn by: CBC
Job: CLARKE
Details

A8

DESIGN CRITERIA:
RISK CATEGORY: 1
DESIGN RISK CATEGORY: I
SNOW LOAD IMPORTANCE FACTOR (I_s): 0.8
SEISMIC IMPORTANCE FACTOR (I_e): 1.0

SEISMIC LOADS
S_v: 0.33
S_{wh}: 0.82
S_{ws}: 1.22
T₁: 8
R: 6.5 (SHEAR WALLS) OR 1.5 (CANTILEVER SYSTEM)
SITE CLASS: D (ASSUMED)
SDC: D

WIND LOADS
V (3 SEC GUST): 105 MPH
EXPOSURE CATEGORY: C
ELEVATION: 5058 FT

SNOW LOADS
P_c: 56 PSF
W_c: 9 PSF
C_s: 1.2
C_t: 1.2
C_e: 1.0
F_s: 45 PSF
F_s: 45 PSF

DEAD LOADS
ROOF: 4 PSF (TRUSSES, PURLINS, METAL)
FLOOR: 10 PSF (JOISTS, OSB)
WALLS: 3 PSF (POSTS, GIRTS, METAL)
DECKS: 10 PSF (JOISTS, DECKING)
CONCRETE: 145 PSF

LIVE LOADS
ROOF: 20 PSF
FLOOR: 40 PSF
DECK: 60 PSF

SOIL LOADS AND VALUES (ASSUMED):
SOIL BEARING PRESSURE: 1500 PSF
ACTIVE PRESSURE: 35 PCF
PASSIVE PRESSURE: 250 PCF
AT-REST PRESSURE: 60 PCF
LATERAL BEARING PRESSURE: 400 PSF/FT
 (IBC 1806.1, 1806.2, & 1806.3.4)

*SEE NOTES FOR SOIL ASSUMPTIONS AS FOUND IN THE CONCRETE FOOTINGS & FOUNDATIONS SECTION, THIS PAGE
 **ENGINEER ASSUMES STABLE SOIL CONDITIONS. IF THERE ARE ANY GLOBAL STABILITY CONCERNS, A GEOTECHNICAL REPORT IS REQUIRED.
 ***VALUES ASSUMED ARE FOR FOOTINGS AND FOUNDATIONS PLACED IN NATIVE SOIL CONDITIONS.

DIAPHRAGM/SHEATHING SCHEDULE

LOCATION	NOMINAL THICKNESS	SPAN RATING	EDGE NAILING	FIELD NAILING
ROOF W/ DESIGN SNOW LOAD UP TO 40 PSF	7/16"	24/16	8d @ 6" O.C.	8d @ 12" O.C.
ROOF W/ DESIGN SNOW LOAD UP TO 120 PSF	19/32"	40/20	10d @ 6" O.C.	10d @ 12" O.C.
FLOOR	3/4" TONGUE AND GROOVE	48/24	10d @ 6" O.C.	10d @ 12" O.C.

NOTES TO TABLE ABOVE:
 1. ROOF AND FLOOR FRAMING MEMBERS SHALL BE PLACED NO FURTHER THAN 24" O.C.
 2. NAILS SHALL BE CARBON STEEL SMOOTH SHANK COMMON OR GALVANIZED BOX. GALVANIZED NAILS SHALL BE HOT-DIPPED OR MECHANICALLY DEPOSITED.
 3. NAILS SHALL BE DRIVEN WITH THE HEAD OF THE NAIL FLUSH WITH THE SURFACE OF THE SHEATHING.
 4. STRUCTURAL PANELS SHALL BE APA APPROVED, EXPOSURE 1, AND MEET THE REQUIREMENTS OF USDOC PS 2.
 5. FLOOR SHEATHING SHALL BE GLUED TO FRAMING MEMBERS PRIOR TO NAILING W/ AN ADHESIVE CONFORMING TO APA SPECIFICATIONS.
 6. STRENGTH AXIS (LONG DIRECTION) OF PANELS SHALL BE ORIENTED PERPENDICULAR TO FRAMING MEMBERS AND PANEL END JOINTS SHALL BE STAGGERED.
 7. NAILS SHALL BE LOCATED AT LEAST 3/8" FROM THE EDGES OF PANELS.
 8. 1-1/2" LONG 16 GAGE STAPLES W/ 7/16" CROWN MAY BE SUBSTITUTED FOR 8d NAILS AT HALF THE SPACING FOR 7/16" PANELS ONLY. CROWNS SHALL BE INSTALLED PARALLEL TO FRAMING MEMBERS.
 9. PANELS SHALL NOT BE LESS THAN 4'X8' EXCEPT AT BOUNDARIES AND CHANGES IN FRAMING WHERE MINIMUM PANEL DIMENSION SHALL BE 24" UNLESS ALL EDGES OF THE UNDERSIZED PANELS ARE SUPPORTED BY AND FASTENED TO FRAMING MEMBERS OR BLOCKING.

CONCRETE FOOTINGS, FOUNDATIONS, AND SLABS

NOTES:
 1. CONCRETE SHALL MEET REQUIREMENTS OUTLINED IN THE BUILDING CODE REQUIREMENTS FOR STRUCTURAL CONCRETE (ACI318-19)
 2. LOTS SHALL BE GRADED TO DRAIN SURFACE WATER AWAY FROM ALL FOUNDATION WALLS. THE GRADE SHALL FALL A MINIMUM OF 6 IN WITHIN THE FIRST 10 FT DISTANCE FROM THE BUILDING.
 3. IMPERVIOUS SURFACES (I.E. CONCRETE, ASPHALT) SHALL BE SLOPED A MINIMUM OF 2% AWAY FROM THE BUILDING
 4. CONTRACTOR SHALL DAMP PROOF ALL CONCRETE WALLS THAT RETAIN EARTH OR HAVE ENCLOSED USABLE SPACES BY PLACING A BITUMINOUS COATING ON BELOW GRADE EXTERIOR SECTIONS OF FOUNDATION WALL OR WITH ANOTHER APPROVED DAMP PROOFING METHOD AS OUTLINED IN R406 OF THE IRC.
 5. FOUNDATION DRAINAGE SYSTEM IS NOT REQUIRED IF BACKFILLED WITH WELL-DRAINING BACKFILL OR SAND-GRAVEL MIXTURE SOILS OF GROUP 1 SOILS OF THE UNIFIED SOILS CLASSIFICATION SYSTEM AS SHOWN IN TABLE R405.1 OF THE IRC.
 6. ALL CONCRETE WALLS THAT RETAIN EARTH AND ANY FOUNDATION WALLS THAT ENCLOSE USABLE AREAS WITH GROUP II-GROUP IV SOILS OF THE UNIFIED SOILS CLASSIFICATIONS SYSTEM AS SHOWN IN TABLE R405.1 OF THE IRC SHALL HAVE A FOUNDATION DRAIN INSTALLED CONSISTING OF A PERFORATED DRAIN PIPE NOT LESS THAN 1" BEYOND THE OUTSIDE EDGE OF THE FOOTINGS AND 6" ABOVE THE TOP OF FOOTING WITH A GRAVEL DRAIN WRAPPED IN AN APPROVED FILTER FABRIC.
 7. ANY FOUNDATION WALLS THAT ENCLOSE USABLE SPACE WITH A HIGH WATER TABLE OR OTHER SEVERE GROUND WATER CONDITIONS SHALL BE WATERPROOFED AS REQUIRED IN SECTION R406.2 OF THE IRC.
 8. WPE ASSUMES STABLE SOIL CONDITIONS. CONTACT ENGINEER IF SOIL CONDITIONS DIFFER FROM THOSE ASSUMED. SEE DESIGN CRITERIA FOR ASSUMED VALUES. THESE VALUES SHALL BE REPLACED BY DATA INCLUDED IN A SITE SPECIFIC GEOTECHNICAL REPORT IF AVAILABLE.
 9. CRUSHED ROCK OR GRAVEL FILL WITH RELATIVELY LOW AMOUNTS OF FINES MAY BE USED TO BRING BOTTOM OF FOOTINGS OR SLABS UP TO GRADE WITH A MAXIMUM GRAVEL FILL DEPTH OF 2'. GRAVEL OR CRUSHED ROCK FILLS SHALL BE COMPACTED USING A VIBRATORY PLATE COMPACTOR.
 10. ANY FILL SOILS OR GRAVEL FILL DEEPER THAN 2' THAT SUPPORT FOOTINGS AND FOUNDATIONS SHALL BE DESIGNED BY A LICENSED GEOTECHNICAL ENGINEER. FILL SOILS SHALL BE INSTALLED, AND TESTED IN ACCORDANCE WITH ACCEPTED ENGINEERING PRACTICE.
 11. WHERE QUANTIFIABLE DATA OR OBSERVATIONS INDICATE EXPANSIVE, COMPRESSIBLE, SHIFTING, OR OTHER QUESTIONABLE SOIL CHARACTERISTICS OR GEOTECHNICAL HAZARDS ARE LIKELY TO BE PRESENT, THE BUILDING OFFICIAL SHALL DETERMINE WHETHER TO REQUIRE A SITE SPECIFIC GEOTECHNICAL STUDY TO DETERMINE SOIL CHARACTERISTICS OF THE SITE.
 12. FROST DEPTH OF FOOTINGS AND MINIMUM FREEBOARD OF FOUNDATION WALLS SHALL BE MET AS SPECIFIED BY JURISDICTION. NO FOOTINGS IN UNCONDITIONED SPACE SHALL BE CONSTRUCTED SHALLOWER THAN THE MINIMUM FROST DEPTH.
 13. CONCRETE SHALL BE MECHANICALLY VIBRATED WHEN PLACED TO AVOID HONEYCOMBING ALONG FORMS AND TO HELP CONCRETE FREELY FLOW AROUND REINFORCEMENT.
 14. CONCRETE SHALL NOT BE DROPPED MORE THAN 5' MAXIMUM DURING PLACEMENT.
 15. CONCRETE FOR FOUNDATION WALLS SHALL CURE A MINIMUM OF 7 DAYS AND HAVE INTERIOR SLAB INSTALLED PRIOR TO ANY BACKFILL. FOUNDATION WALLS 6' IN HEIGHT AND ABOVE DESIGNED FOR TOP SUPPORT. CONTRACTOR SHALL INSTALL FLOOR OR ROOF DIAPHRAGM PRIOR TO BACKFILL AND SHALL NOT COMPACT ANY BACKFILL PLACED AROUND THESE WALLS.
 16. ALL FOUNDATIONS SHALL HAVE 6" MIN. EXPOSED ABOVE GRADE.
 17. CONTRACTOR SHALL ROUGHEN COLD JOINT BETWEEN FOOTING AND WALL TO 1/4" AMPLITUDE.
 18. ALL SLABS ON GRADE SHALL HAVE CONTROL JOINTS IN SLAB AT 15' O.C. MAXIMUM SPACING.
 19. ALL CONCRETE SLABS ON GRADE SHALL BE A MINIMUM OF 4" THICK ON 4" PLATE COMPACTED GRAVEL OR OTHER APPROVED FREE DRAINING MATERIAL.
 20. REINFORCING STEEL IN CONCRETE SHALL MEET THE REQUIREMENTS OF THE FOLLOWING SECTION ENTITLED "REINFORCING STEEL".
 21. ALL REINFORCEMENT IN CONCRETE SHALL BE PROPERTY TIED AND SECURED PRIOR TO POURING CONCRETE IN SUCH A WAY THAT REINFORCEMENT REMAINS IN DESIGNED LOCATION. VERTICAL REINFORCING STEEL FOR MASONRY CONSTRUCTION MAY BE FLOATED INTO PLACE.
 22. ANY COMPONENTS THAT ARE CAST IN PLACE SHALL BE SECURELY PLACED IN THE FORMS (I.E. STRAPS, BOLTS, SLEEVES, ETC.)
 23. REINFORCEMENT IN FOUNDATION WALLS SHALL BE CENTERED IN WALL U.N.O. REINFORCEMENT FOR CONCRETE WALLS RETAINING EARTH SHALL BE PLACED WHERE DESIGNED ON PLANS.
 24. ENGINEER ASSUMES 2,500 PSI COMPRESSIVE STRENGTH IN STRUCTURAL CONCRETE. THEREFORE CONCRETE FOR FOOTINGS, FOUNDATION WALLS, AND SLABS ON GRADE CAN BE EXEMPT FROM SPECIAL INSPECTIONS ACCORDING TO EXEMPTIONS LISTED IN SECTION 1705.3 IN THE IBC UNLESS NOTED OTHERWISE.

CONCRETE SPECIFICATIONS

STRUCTURAL ELEMENT	MIN. COMPRESSIVE STRENGTH (f _c)	AIR CONTENT	W/C RATIO
FOUNDATION WALLS AND FOOTINGS, NOT EXPOSED TO WEATHER	3000 PSI	5%-7% ⁽¹⁾	.55
SLABS (EXCLUDING GARAGE SLABS)	3000 PSI	5%-7% ⁽¹⁾	.55
WALLS, EXPOSED TO WEATHER	3000 PSI	5%-7%	.45
SLABS EXPOSED TO WEATHER (INCLUDING GARAGE AND SUSP SLABS)	3500 PSI	5%-7%	.45

NOTES TO TABLE ABOVE:
 1. AIR ENTRAINMENT ONLY REQUIRED IN CONCRETE NOT EXPOSED TO WEATHER IF EXPOSED TO FREEZE/THAW DURING CONSTRUCTION.
 2. f_c IS CONCRETE COMPRESSIVE STRENGTH AT 28-DAYS
 3. PORTLAND CEMENT TYPE III
 4. W/C RATIO BASED ON ALL CEMENTITIOUS AND SUPPLEMENTARY CEMENTITIOUS MATERIAL IN CONCRETE MIXTURE.
 5. CONCRETE SHALL NOT INCLUDE CALCIUM CHLORIDE ADMIXTURE
 6. NOMINAL MAXIMUM AGGREGATE SIZE OF 3/4" AND SHALL CONFORM TO ASTM C33
 7. CONCRETE MIXTURE MAY HAVE A MAXIMUM OF 25% BY MASS OF FLY ASH OR OTHER NATURAL POZZOLANS CONFORMING TO ASTM C618
 8. SEE SECTION R404.1.3.3.4 (IRC 2021) FOR SLUMP REQUIREMENTS. SLUMP OF CONCRETE SHALL BE ADEQUATE TO PROVIDE WORKABILITY AROUND REINFORCEMENT.

REINFORCING STEEL:

NOTES:
 1. PLACEMENT OF REINFORCING STEEL SHALL MEET REQUIREMENTS OF CHAPTER 25 OF ACI 318-19.
 2. ALL REINFORCING STEEL SHALL CONFORM TO ASTM A-615 GRADE 60 (F_y = 60 KSI).
 3. REINFORCING STEEL SHALL NOT BE WELDED UNLESS SPECIFIED ON THE PLANS. REINFORCING STEEL THAT IS WELDED SHALL BE ASTM A806 GRADE 60.
 4. REINFORCING WELDED WIRE FABRIC SHALL CONFORM TO ASTM STANDARD A-185.
 5. ALL REINFORCING STEEL DIMENSIONS SHALL BE TO CENTER OF BAR UNLESS DIMENSION IS SPECIFIED AS "CLEAR" OR "CLR" IN WHICH CASE THE DIMENSION IS TO EDGE OF REBAR.
 6. EDGE DISTANCE, HOOK AND BEND RADII, AND REBAR LAP LENGTHS SHALL MEET THE FOLLOWING REQUIREMENTS ON THIS SHEET AND THE REQUIREMENTS IN THE ACI 318.
 7. REINFORCING IN FOUNDATION WALLS AND AROUND OPENINGS SHALL MEET REQUIREMENTS OF THE FOUNDATION SCHEDULE SHOWN ON S1.0 AND THE UTAH AMENDMENT TO THE CODE 15A-3-108.
 8. ON CENTER (O.C.) SPACING SHOWN ON PLANS SHALL BE MAXIMUM SPACING ALLOWABLE.
 9. BARS SHALL BE LAPPED A MINIMUM OF 40 BAR DIAMETERS (d_b) TO MEET DEVELOPMENT LENGTH. DEVELOPMENT LENGTH ASSUMES UNEPOXIED REBAR AND NORMAL WEIGHT CONCRETE. CONTACT ENGINEER FOR OTHER CONDITIONS IF NEEDED.

FRAMING

NOTES:
 1. ALL LUMBER SHALL MEET PLANS SPECIFICATIONS AND BE GRADED AND STAMPED BY AN APPROVED AGENCY (I.E. APA, WWPA, ETC.)
 2. BEAMS ON PLAN ARE SIZED AS A MINIMUM. LARGER SIZES AND HIGHER GRADES MAY REPLACE MEMBERS ON PLAN.
 3. BEAMS CONSISTING OF (4) OR MORE PLYS SHALL BE FASTENED W/ (2) ROWS OF 1/2" DIA THRU BOLTS @ 12" O.C. 2" FROM TOP AND 2" FROM BOTTOM OF BEAM.
 4. HOLES FOR BOLTS SHALL BE A MINIMUM OF 1/32" TO A MAXIMUM OF 1/16" LARGER THAN THE BOLT DIAMETER. A STANDARD CUT WASHER SHALL BE PROVIDED BETWEEN THE WOOD AND THE BOLT HEAD AND BETWEEN THE WOOD AND THE NUT.
 5. LEAD HOLES FOR LAG SCREWS SHALL BE BORED AS FOLLOWS
 A) THE CLEARANCE HOLE FOR THE THE SHANK SHALL HAVE THE SAME DIAMETER AS THE SHANK AND THE SAME DEPTH OF PENETRATION AS THE LENGTH OF UNTHREADED SHANK.
 B) THE LEAD HOLE FOR THE THREADED PORTION SHALL HAVE A DIAMETER EQUAL TO 40%-70% OF THE SHANK DIAMETER AND A LENGTH EQUAL TO AT LEAST THE LENGTH OF THE THREADED PORTION. THE LARGER PERCENTILE SHALL APPLY TO LAG SCREWS OF GREATER DIAMETERS.
 9. POSTS AND WALLS SHALL BE CENTERED ON CONTINUOUS AND SPOT FOOTINGS U.N.O.
 10. ENGINEERED WOOD RIM BOARDS SHALL CONFORM TO ANSI/APA PRR 410 OR SHALL BE EVALUATED IN ACCORDANCE W/ ASTM D7672.
 11. WOOD CONSTRUCTION CONNECTORS SHALL BE INSTALLED PER THE MANUFACTURER'S SPECIFICATIONS.

GENERAL CONSTRUCTION NOTES:

1. ALL CONSTRUCTION WORK SHALL FOLLOW THE STANDARDS FOUND IN THE INTERNATIONAL BUILDING CODE (IBC 2021) AND THE NATIONAL DESIGN SPECIFICATIONS FOR WOOD CONSTRUCTION (NDS 2018).
 2. THE ENGINEERED DRAWINGS PROVIDED HEREIN WERE COMPLETED USING THE PROFESSIONAL STANDARD OF CARE REQUIRED BY THE GOVERNING MUNICIPALITY AND/OR STATE. THESE DRAWINGS, HOWEVER, DO NOT AND CAN NOT PROVIDE EVERY EXPLICIT ELEMENT OR CONDITION OF THE STRUCTURE. AS SUCH, CONTRACTOR SHALL PROVIDE INDUSTRY STANDARD GOOD CARE AND PRACTICE FOR MISCELLANEOUS ELEMENTS NOT SHOWN ON PLANS AND SHALL CONTACT ENGINEER FOR FURTHER INFORMATION IF REQUIRED.
 3. STRUCTURAL ENGINEERING PROVIDED HEREIN ASSUMES FINAL CONSTRUCTED CONDITION. CONTRACTOR SHALL BE RESPONSIBLE FOR STRUCTURAL INTEGRITY OF UNFINISHED STRUCTURE DURING ALL STAGES OF CONSTRUCTION. CONSTRUCTION LOADS SHALL NOT EXCEED DESIGN LIVE LOADS SHOWN IN DESIGN CRITERIA. CONTRACTOR SHALL PROVIDE BRACING OR SHORING AS NECESSARY TO SUPPORT UNFINISHED STRUCTURE.
 4. WHITE PINE ENGINEERING (WPE) ASSUMES NO LIABILITY FOR THE MEANS AND METHODS OF CONSTRUCTION PRACTICES. CONTRACTOR IS RESPONSIBLE FOR ALL MEANS OF CONSTRUCTION AND FOR JOBSITE SAFETY PER OSHA REGULATIONS
 5. CONTRACTOR SHALL BE RESPONSIBLE FOR RECEIVING APPROVAL AND ANY NECESSARY PERMITS FROM THE GOVERNING MUNICIPALITY PRIOR TO BEGINNING OF CONSTRUCTION.
 6. ANY OBSERVATIONS PROVIDED BY WPE DURING CONSTRUCTION SHALL BE CONSIDERED OBSERVATIONS LIMITED TO THE SCOPE REQUESTED, AND NOT FULL INSPECTIONS OR APPROVAL. THE GOVERNING MUNICIPALITY SHALL BE SOLELY RESPONSIBLE FOR INSPECTIONS AND APPROVAL OF FINAL CONSTRUCTION.
 7. CONTRACTOR SHALL INFORM ENGINEER OF ANY DISCREPANCIES BETWEEN ACTUAL CONDITIONS AND CONDITIONS ASSUMED ON THESE PLANS (I.E. DIMENSIONS, MATERIALS, ASSUMED LOADS, ETC.)
 8. SHOP DRAWINGS FOR ANY PRE-MANUFACTURED STRUCTURAL ELEMENTS SHALL BE STAMPED BY A PROFESSIONAL ENGINEER LICENSED IN THE STATE OF CONSTRUCTION AND SHALL BE SUBMITTED TO THE ENGINEER OF RECORD TO REVIEW IF DIMENSIONS OR OTHER ASPECTS OF SHOP DRAWINGS DIFFER FROM THOSE ON THESE PLANS.

REBAR CONCRETE COVERAGE DISTANCES

EXPOSURE CONDITION	BAR SIZE OR MEMBER	REBAR CLR DISTANCE (MIN.)
CAST AGAINST AND PERMANENTLY EXPOSED TO EARTH	ANY	3"
EXPOSED TO WEATHER	#5 AND SMALLER	1-1/2"
	#6 AND LARGER	2"
NOT EXPOSED TO WEATHER OR IN CONTACT WITH GROUND	#14 AND # 18; SLABS, JOISTS, AND WALLS	1-1/2"
	#11 AND SMALLER; SLABS, JOISTS, AND WALLS	3/4"
	ALL SIZE BARS; BEAMS, COLUMNS, AND TENSION TIES	1-1/2"

NOTES TO TABLE ABOVE:
 1. SEE TABLE 20.5.1.3.1 ACI 318-19
 2. ALL SLAB ON GRADE REINFORCEMENT SHALL BE CENTERED IN SLAB UNLESS NOTED OTHERWISE

TRUSSES

NOTES:
 1. PRE-MANUFACTURED TRUSSES SHALL FOLLOW LAYOUT SHOWN ON PLANS. ANY CHANGES IN TRUSS LAYOUT SHALL BE BROUGHT TO THE ATTENTION OF THE ENGINEER.
 2. CONTRACTOR AND MANUFACTURER SHALL VERIFY CEILING HEIGHTS, TRAYS, VAULTS, AND STEPS PRIOR TO CONSTRUCTION.
 3. MULTI PLY TRUSSES OR JOISTS SHALL BE FASTENED PER MANUFACTURER'S SPECIFICATIONS.
 4. TRUSSES AND JOISTS SHALL BE BRACED PER MANUFACTURER.
 5. NO ALTERATIONS OF TRUSSES OR JOISTS ARE ALLOWED WITHOUT APPROVAL FROM MANUFACTURER.

SHEAR WALL SCHEDULE

MARK	SHEATHING	EDGE NAILING	EDGE STAPLING	EDGE MEMBER	FIELD NAILING	FIELD STAPLING	FIELD MEMBER	PLF
SW-6"	7/16" OSB, 1 SIDE	8d @ 6" O.C.	1-1/2" LONG 16 GAUGE @ 3" O.C.	(1) 2X	8d @ 6" O.C.	1-1/2" LONG 16 GAUGE @ 6" O.C.	(1) 2X	240
SW-4"	7/16" OSB, 1 SIDE	8d @ 4" O.C.	1-1/2" LONG 16 GAUGE @ 2" O.C.	(1) 3X OR (2) 2X W/ 16d @ 4" O.C.	8d @ 6" O.C.	1-1/2" LONG 16 GAUGE @ 6" O.C.	(1) 2X	350
SW-3"	7/16" OSB, 1 SIDE	8d @ 3" O.C.	N/A	(1) 3X OR (2) 2X W/ 16d @ 4" O.C.	8d @ 6" O.C.	N/A	(1) 2X	450
SW-2"	7/16" OSB, 1 SIDE	8d @ 2" O.C.	N/A	(1) 3X OR (2) 2X W/ 16d @ 3" O.C.	8d @ 6" O.C.	N/A	(1) 2X	585
(2)SW-4"	7/16" OSB, BOTH SIDES	8d @ 4" O.C.	1-1/2" LONG 16 GAUGE @ 2" O.C.	(1) 3X OR (2) 2X W/ 16d @ 4" O.C.	8d @ 6" O.C.	1-1/2" LONG 16 GAUGE @ 6" O.C.	(1) 2X	700
(2)SW-3"	7/16" OSB, BOTH SIDES	8d @ 3" O.C.	N/A	(1) 3X OR (2) 2X W/ 16d @ 4" O.C.	8d @ 6" O.C.	N/A	(1) 2X	900
(2)SW-2"	7/16" OSB, BOTH SIDES	8d @ 2" O.C.	N/A	(1) 3X OR (2) 2X W/ 16d @ 3" O.C.	8d @ 6" O.C.	N/A	(1) 2X	1170

NOTES TO TABLE ABOVE:
 1. GIRTS SHALL BE DF-L @ 24" O.C.
 2. NAILS SHALL BE CARBON STEEL SMOOTH SHANK 8d COMMON OR 8d GALVANIZED BOX. GALVANIZED NAILS SHALL BE HOT-DIPPED OR MECHANICALLY DEPOSITED.
 3. STAPLES SHALL HAVE A MINIMUM CROWN WIDTH OF 7/16" AND SHALL BE INSTALLED WITH THEIR CROWNS PARALLEL TO THE LONG DIMENSION OF THE FRAMING MEMBERS.
 4. NAILS/STAPLES SHALL BE DRIVEN WITH THE HEAD/CROWN OF THE NAIL/STAPLE FLUSH WITH THE SURFACE OF THE SHEATHING.
 5. DOUBLE SIDED SHEAR WALLS SHALL HAVE PANEL JOINTS OFFSET TO FALL ON DIFFERENT FRAMING MEMBERS. NAILS AT PANEL EDGES SHALL BE STAGGERED.
 6. BLOCK ALL PANEL EDGES. FLAT BLOCKING/GIRTS IS ACCEPTABLE ON SINGLE SIDED SHEAR WALLS.
 7. ALL WALLS SHALL FOLLOW SW-6" U.N.O.
 8. STRUCTURAL PANELS SHALL BE APA APPROVED, EXPOSURE 1, AND MEET THE REQUIREMENTS OF USDOC PS 2.
 9. NAILS SHALL BE LOCATED AT LEAST 3/8" FROM THE PANEL EDGES.
 10. PANELS SHALL NOT BE LESS THAN 4'X8' EXCEPT AT BOUNDARIES AND CHANGES IN FRAMING. ALL EDGES OF ALL PANELS SHALL BE SUPPORTED BY AND FASTENED TO FRAMING MEMBERS OR BLOCKING.

**DMLP RESOURCES/
 ROPER BUILDINGS**

(801) 689-3630

CLARKE FARM LLC

4627 East 2650 North Clarke Lane
 Eden, UT 84310

Date: 5/7/2024

Scale:

Drawn by: CBC

Job: CLARKE

Engineering Notes

A9

