

JACQUELYN ESTATES CLUSTER SUBDIVISION PHASE 1

A PART OF THE NORTHWEST QUARTER OF SECTION 29, T. 6 N., R. 2 W., S.L.B. & M.

WEBER COUNTY, UTAH

JANUARY 2015

N 1/4 COR OF SEC 29,
T6N, R2W, S18M
FOUND WEBER CO MONUMENT
DATED 1963, FAIR CONDITION

SURVEYORS CERTIFICATE

I, DALLAS K. BUTTARS, HOLDING PROFESSIONAL LAND SURVEYOR'S LICENSE NO. 167594, IN ACCORDANCE WITH TITLE 58, CHAPTER 22 OF THE PROFESSIONAL ENGINEERS AND LAND SURVEYORS LICENSING ACT, HAVE COMPLETED A SURVEY OF THE PROPERTY DESCRIBED ON THE PLAT IN ACCORDANCE WITH SECTION 17-29-17 AND HAVE VERIFIED ALL MEASUREMENTS AND PLACED MONUMENTS AS REPRESENTED ON THE PLAT. THIS SURVEY WAS PREPARED FROM RECORDS IN THE RECORDERS AND SURVEYORS OFFICE AND I FURTHER CERTIFY THAT ALL LOTS MEET CURRENT LOT WIDTH AND AREA REQUIREMENTS FOR WEBER COUNTY ZONING.

SIGNED THIS _____ DAY OF _____ 20____

P.L.S. #167594

OWNER'S DEDICATION

WE, THE UNDERSIGNED OWNERS OF THE HEREIN DESCRIBED TRACT OF LAND, DO HEREBY SET APART AND SUBDIVIDE THE SAME INTO LOTS AND STREETS AS SHOWN ON THE PLAT AND NAME SAID TRACT "JACQUELYN ESTATES CLUSTER SUBDIVISION PHASE 1" AND DO HEREBY DEDICATE, GRANT AND CONVEY TO WEBER COUNTY, UTAH, ALL THOSE PARTS OR PORTIONS OF SAID TRACT OF LAND DESIGNATED AS STREETS TO BE USED AS PUBLIC THROUGHWAYS FOREVER, AND ALSO GRANT AND DEDICATE A PERPETUAL RIGHT AND EASEMENT OVER, UPON AND UNDER THE LANDS DESIGNATED ON THE PLAT AS PUBLIC UTILITY, STORM WATER DETENTIONS Ponds AND DRAINAGE EASEMENTS, THE SAME TO BE USED FOR THE INSTALLATION, MAINTENANCE AND OPERATION OF PUBLIC UTILITY SERVICE LINES, STORM DRAINAGE FACILITIES OR FOR THE PERPETUAL PRESERVATION OF WATER CHANNELS IN THEIR NATURAL STATE WHICH EVER IS APPLICABLE AS MAY BE AUTHORIZED BY WEBER COUNTY, UTAH, WITH NO BUILDINGS OR STRUCTURES BEING ERRECTED WITHIN SUCH EASEMENTS, AND HEREBY GRANT A TEMPORARY TURN AROUND EASEMENT AS SHOWN HEREIN TO BE USED BY THE PUBLIC UNTIL SUCH TIME THAT THE ROAD IS EXTENDED THE TEMPORARY TURN AROUND EASEMENT SHALL BE REVOKED AND NULLIFIED AT THE EVENT OF THE EXTENSION OF THE ROAD WITHOUT FURTHER WRITTEN DOCUMENT AND THE ENCUMBERED LAND WITHIN THE AFFECTED LOTS SHALL BE RELEASED FOR THE FULL AND EXCLUSIVE USE AND BENEFIT OF THE LOT OWNERS.

SIGNED THIS _____ DAY OF _____ 20____

PRESIDENT CJ HJMES

CORPORATE ACKNOWLEDGMENT

State of Utah)
County of _____)
On this _____ day of _____, 2____, _____ personally appeared before me _____ (name of document signer) personally known to me (or proven on the basis of satisfactory evidence) and who by me duly sworn/affirmed, did say that he/she is the _____ of _____ (Title or Office) (Name of Corporation) and that said document was signed by him/her in behalf of said Corporation by Authority of its Bylaws, or (Resolution of its Board of Directors), and said _____ (name of document signer) acknowledged to me that said Corporation executed the same.

Notary Public _____

BOUNDARY DESCRIPTION

A PART OF THE NORTHWEST QUARTER OF SECTION 29, TOWNSHIP 6 NORTH, RANGE 2 WEST, SALT LAKE BASE AND MERIDIAN, U.S. SURVEY, DESCRIBED AS FOLLOWS: BEGINNING AT A POINT ON THE QUARTER SECTION LINE, SAID POINT ALSO BEING NORTH 89°02'15" WEST 142.78 FEET ALONG THE QUARTER SECTION LINE FROM THE CENTER OF SAID SECTION 29, AND RUNNING THENCE NORTH 89°02'15" WEST 585.00 FEET ALONG THE QUARTER SECTION LINE TO THE EAST R.O.W. LINE OF 4900 WEST STREET EXTENDED; THENCE NORTH 00°25'30" EAST 654.39 FEET ALONG SAID R.O.W. LINE OF 4900 WEST STREET; THENCE SOUTH 89°41'30" EAST 104.86 FEET; THENCE SOUTHEASTERLY 142.06 FEET ALONG THE ARC OF A 125.00 FOOT RADIUS CURVE TO THE RIGHT WITH A CENTRAL ANGLE OF 65°07'00" (L.C. = SOUTH 57°01'00" EAST 134.54 FEET); THENCE NORTH 60°42'02" EAST 104.10 FEET; THENCE SOUTH 89°17'17" EAST 45.60 FEET; THENCE NORTH 24°31'23" EAST 77.20 FEET; THENCE SOUTH 61°46'26" EAST 14.50 FEET; THENCE SOUTH 00°25'30" WEST 140.00 FEET; THENCE SOUTH 35°11'08" WEST 60.86 FEET; THENCE NORTH 89°34'30" WEST 22.10 FEET; THENCE SOUTH 07°38'13" WEST 116.20 FEET; THENCE SOUTH 77°21'58" EAST 131.42 FEET; THENCE SOUTH 43°05'00" EAST 89.40 FEET; THENCE SOUTH 41°37'05" EAST 41.40 FEET; THENCE SOUTH 00°57'45" WEST 134.00 FEET TO THE POINT OF BEGINNING. CONTAINS 281,635.82 SQFT = 6.465 ACRES.

NARRATIVE

THE PURPOSE OF THIS SURVEY WAS TO CREATE A SIX (6) LOT CLUSTER SUBDIVISION AS SHOWN. SURVEY WAS USED TO AID IN THIS PLAT. STEVE WEST SUBDIVISION, HOLGATE SUBDIVISION AND HOLGATE SUBDIVISION - AMENDED LOT 4, AS FOUND IN THE WEBER COUNTY RECORDERS OFFICE. BASIS OF BEARING IS UTAH STATE PLANE BEARING AS SHOWN.

CENTER OF SEC 29,
T6N, R2W, S18M
FOUND WEBER CO MONUMENT
DATED 1963, FAIR CONDITION

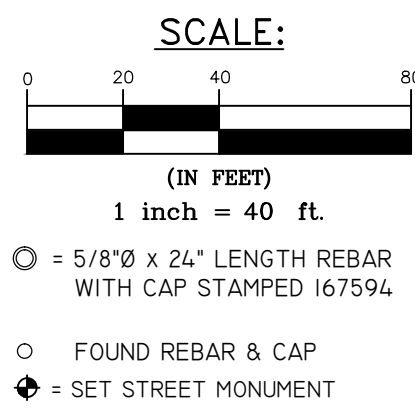
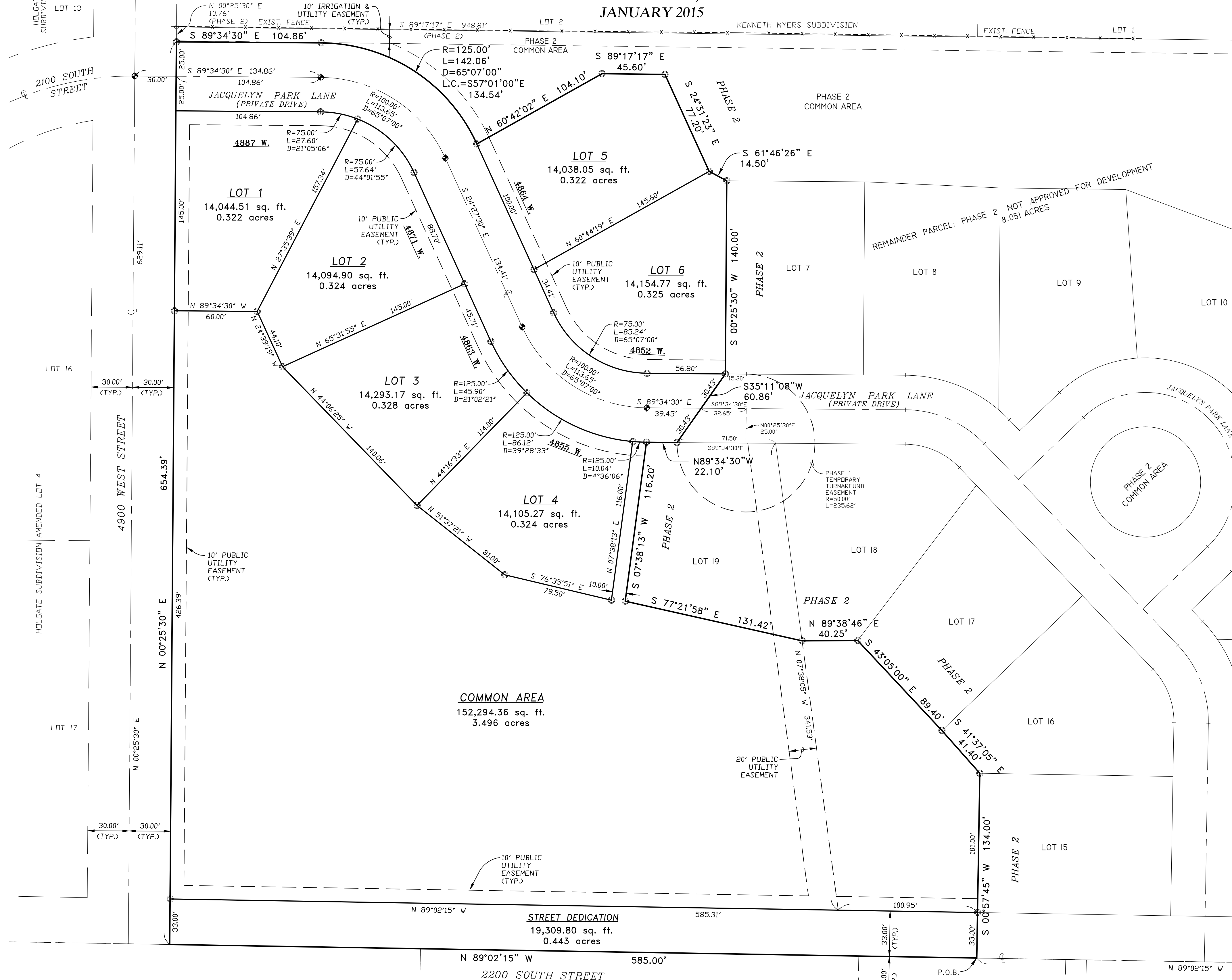

WEBER COUNTY SURVEYOR
I HEREBY CERTIFY THAT THE WEBER COUNTY SURVEYOR'S OFFICE HAS REVIEWED THIS PLAT FOR MATHEMATICAL CORRECTNESS, SECTION CORNER DATA, AND FOR HARMONY WITH LINES AND MONUMENTS ON RECORD IN COUNTY OFFICES. THE APPROVAL OF THIS PLAT BY THE WEBER COUNTY SURVEYOR DOES NOT RELIEVE THE LICENSED LAND SURVEYOR WHO EXECUTED THIS PLAT FROM THE RESPONSIBILITIES AND/OR LIABILITIES ASSOCIATED THEREWITH.
SIGNED THIS _____ DAY OF _____ 20____

SIGNATURE

WEBER COUNTY ENGINEER
I HEREBY CERTIFY THAT THE REQUIRED PUBLIC IMPROVEMENT STANDARDS AND DRAWINGS FOR THIS SUBDIVISION CONFORM WITH COUNTY STANDARDS AND THE AMOUNT OF THE FINANCIAL GUARANTEE IS SUFFICIENT FOR THE INSTALLATION OF THESE IMPROVEMENTS.
SIGNED THIS _____ DAY OF _____ 20____

SIGNATURE

WEBER COUNTY ATTORNEY
I HAVE EXAMINED THE FINANCIAL GUARANTEE AND OTHER DOCUMENTS ASSOCIATED WITH THIS SUBDIVISION PLAT AND IN MY OPINION THEY CONFORM WITH THE COUNTY ORDINANCE APPLICABLE THERETO AND NOW IN FORCE AND EFFECT.
SIGNED THIS _____ DAY OF _____ 20____

SIGNATURE

WEBER-MORGAN HEALTH DEPARTMENT
I HEREBY CERTIFY THAT THE SOILS, PERCOLATION RATES, AND SITE CONDITION FOR THIS SUBDIVISION HAVE BEEN INVESTIGATED BY THIS OFFICE AND ARE APPROVED FOR ON-SITE WASTEWATER DISPOSAL SYSTEMS.
SIGNED THIS _____ DAY OF _____ 20____

DIRECTOR, WEBER-MORGAN HEALTH DEPARTMENT

WEBER COUNTY PLANNING COMMISSION APPROVAL
THIS IS TO CERTIFY THAT THIS SUBDIVISION PLAT WAS DULY APPROVED BY THE WEBER COUNTY PLANNING COMMISSION ON THE _____ DAY OF _____ 20____

CHAIRMAN, WEBER COUNTY COMMISSION

WEBER COUNTY COMMISSION ACCEPTANCE
THIS IS TO CERTIFY THAT THIS SUBDIVISION PLAT, THE DEDICATION OF STREETS AND OTHER PUBLIC WAYS, AND FINANCIAL GUARANTEE OF PUBLIC IMPROVEMENTS ASSOCIATED WITH THIS SUBDIVISION, THEREON ARE HEREBY APPROVED AND ACCEPTED BY THE COMMISSIONERS OF WEBER COUNTY, UTAH THIS _____ DAY OF _____ 20____

TITLE "CHAIRMAN, WEBER COUNTY COMMISSION"
ATTEST:

AGRICULTURAL NOTE
AGRICULTURE IS THE PREFERRED USE IN THE AGRICULTURE ZONES. AGRICULTURE OPERATIONS AS SPECIFIED IN THE ZONING ORDINANCE FOR A PARTICULAR ZONE ARE PERMITTED AT ANY TIME INCLUDING THE OPERATION OF FARM MACHINERY AND NO ALLOWED AGRICULTURE USE SHALL BE SUBJECT TO RESTRICTION ON THE BASIS THAT IT INTERFERES WITH ACTIVITIES OF FUTURE RESIDENTS OF THIS SUBDIVISION.

NOTE: NO BASEMENTS ALLOWED IN THIS DEVELOPMENT.

DEVELOPER:
CJ HJMES
PH: 801-540-4989



LANDMARK SURVEYING, INC.
A COMPLETE LANDSURVEYING SERVICE
4646 S. 3500 W. #A-3, WEST HAVEN, UTAH 84401
PHONE 801-731-4075 FAX 801-731-8506
LANDMARKSURVEYINGUTAH.COM

CLIENT: CRAIG STANDING PH: 801-540-4989
LOCATION: A PART OF THE NORTHWEST 1/4 OF SECTION 29, T.6N., R.2W., S.L.B.&M. WEBER COUNTY, UTAH
SURVEYED: JAN 2014

REVISIONS:	DRAWN BY: D.B. & L.A.
10-10-2014 L.A.	CHECKED BY: D.B.
11-26-2014 L.A.	DATE: AUG 05, 2014
	FILE: 3310FIN-DCT2014.DWG

WEBER COUNTY RECORDER

ENTRY # _____ FEE _____
FILED FOR RECORD & RECORDED
THIS _____ DAY OF _____ 20____
AT _____ IN BOOK _____ OF _____
PAGE _____

WEBER COUNTY RECORDER
BY _____ DEPUTY

BASIS OF BEARING STATE PLANE GRID BEARING PER WEBER COUNTY 2666.687' MEAS. 2666.674' REC. 2666.621' V. S 00°36'21" W