

811
Know what's below.
Call before you dig.

BENCHMARK
NORTHWEST CORNER OF SECTION 27
TOWNSHIP 7 NORTH, RANGE 2 WEST
SALT LAKE BASE AND MERIDIAN
ELEV = 4231.00'

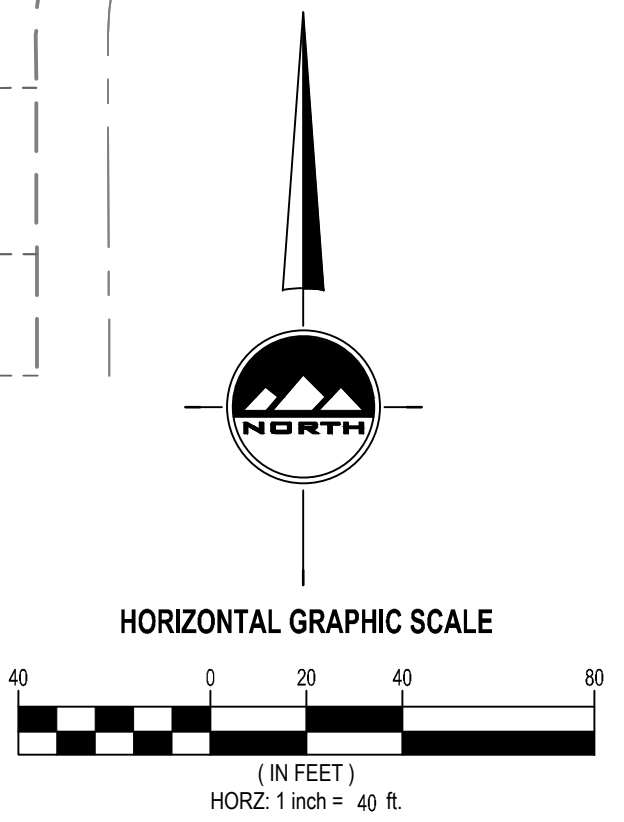
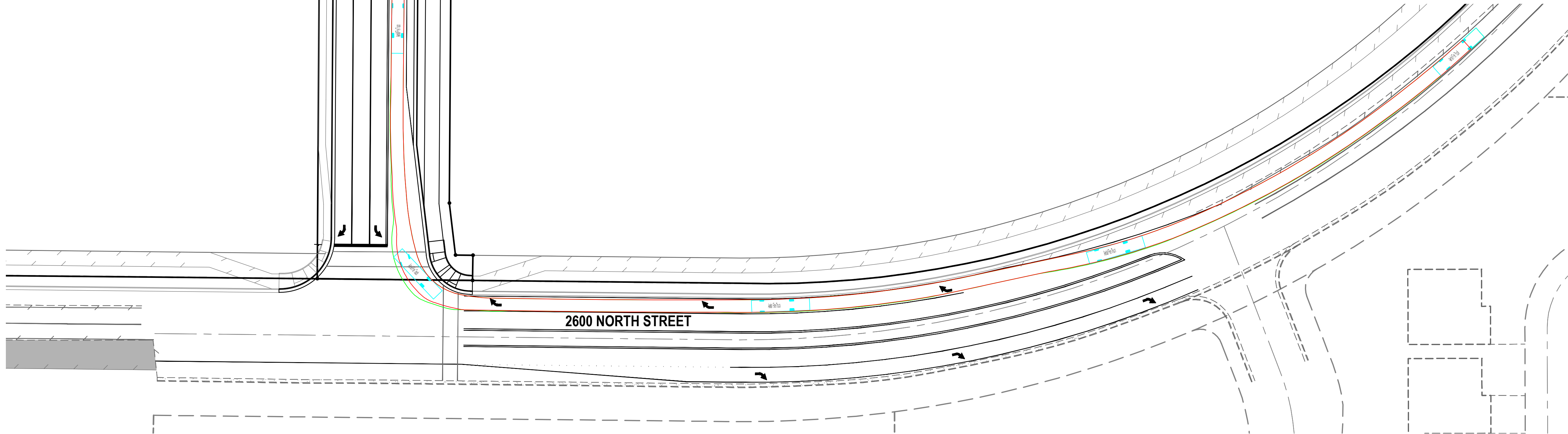
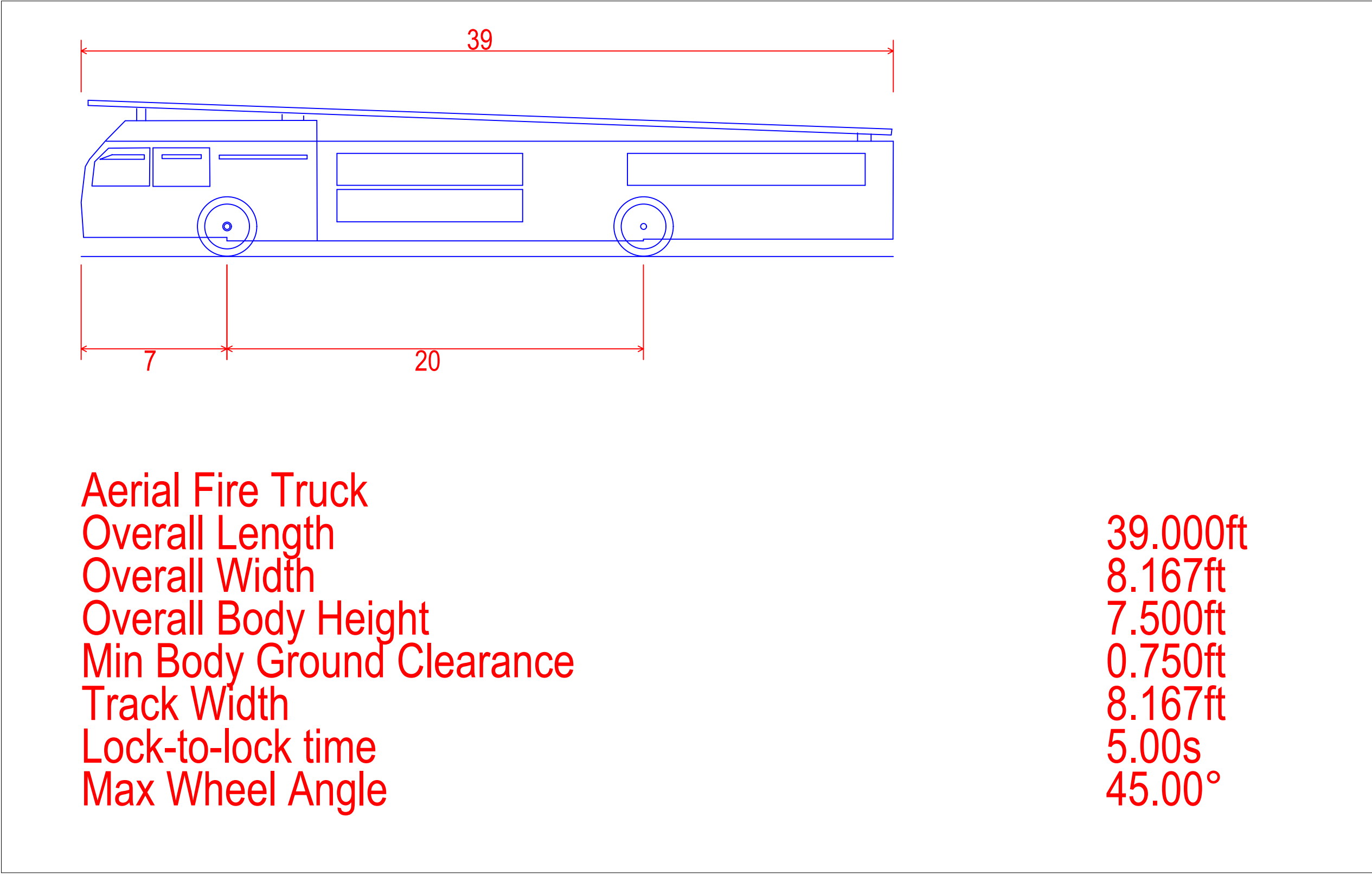
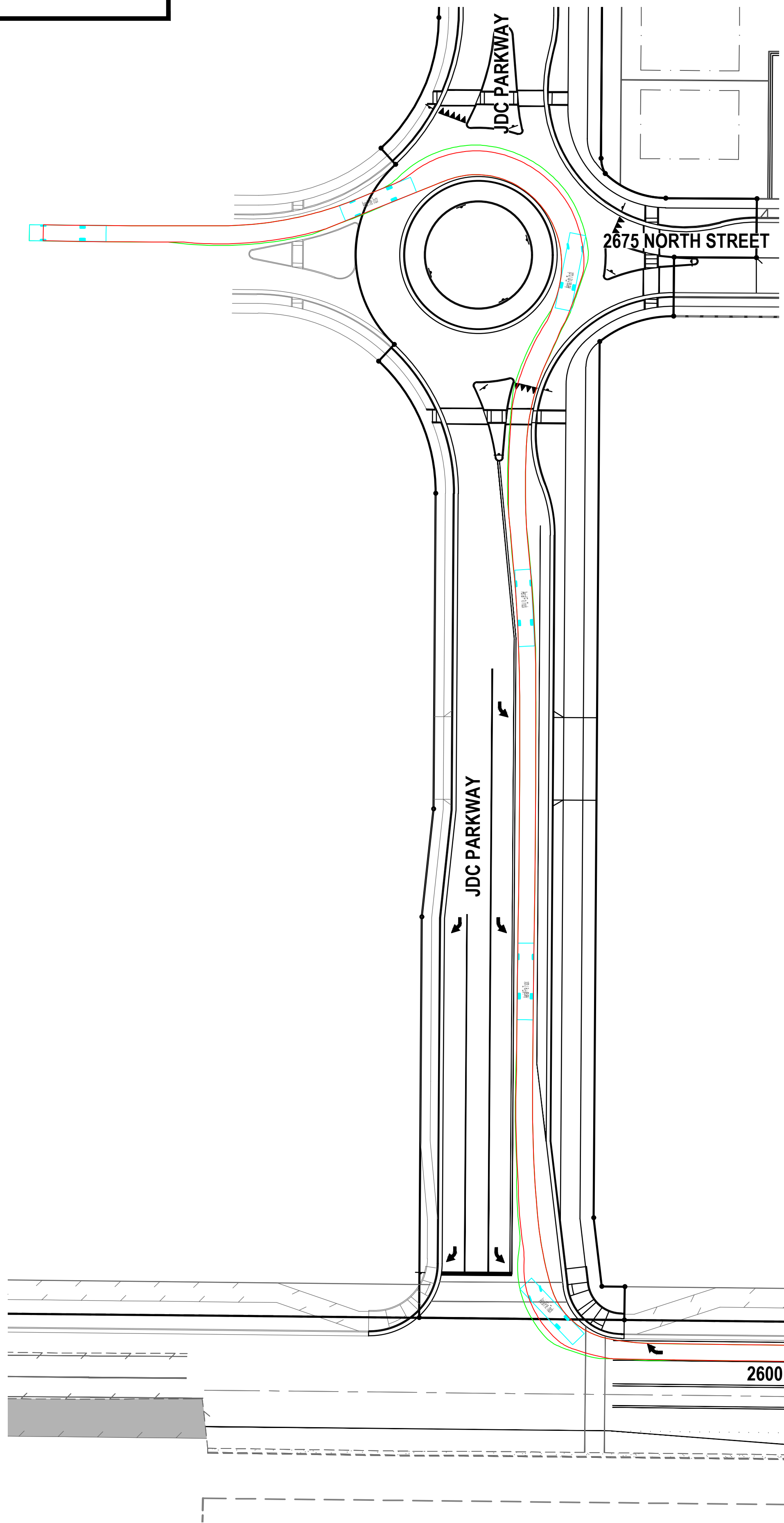

ENSIGN
THE STANDARD IN ENGINEERING

LAYTON
919 North 400 West
Layton, UT 84041
Phone: 801.547.1100

SANDY
Phone: 801.255.0529

TOOELE
Phone: 435.843.3590

CEDAR CITY
Phone: 435.865.1453

RICHFIELD
Phone: 435.896.2983

WWW.ENSIGNENG.COM

FOR:
NILSON HOMES
1740 COMBE RD, SUITE 2
SOUTH OGDEN, UT 84403

CONTACT:
STEVE ANDERSON
PHONE: 801.392.8100

JDC PARKWAY

2800 WEST 2600 NORTH STREET

WEBER COUNTY, UTAH



NO. DATE REVISION FOR REVIEW

**FIRE TRUCK
VEHICLE TRACKING
EXHIBIT**

PROJECT NUMBER 9872
PROJECT MANAGER CP

PRINT DATE 2023-10-16
DESIGNED BY TS

EX-1

811
Know what's below.
Call before you dig.

BENCHMARK
NORTHWEST CORNER OF SECTION 27
TOWNSHIP 7 NORTH, RANGE 2 WEST
SALT LAKE BASE AND MERIDIAN
ELEV = 4231.00'

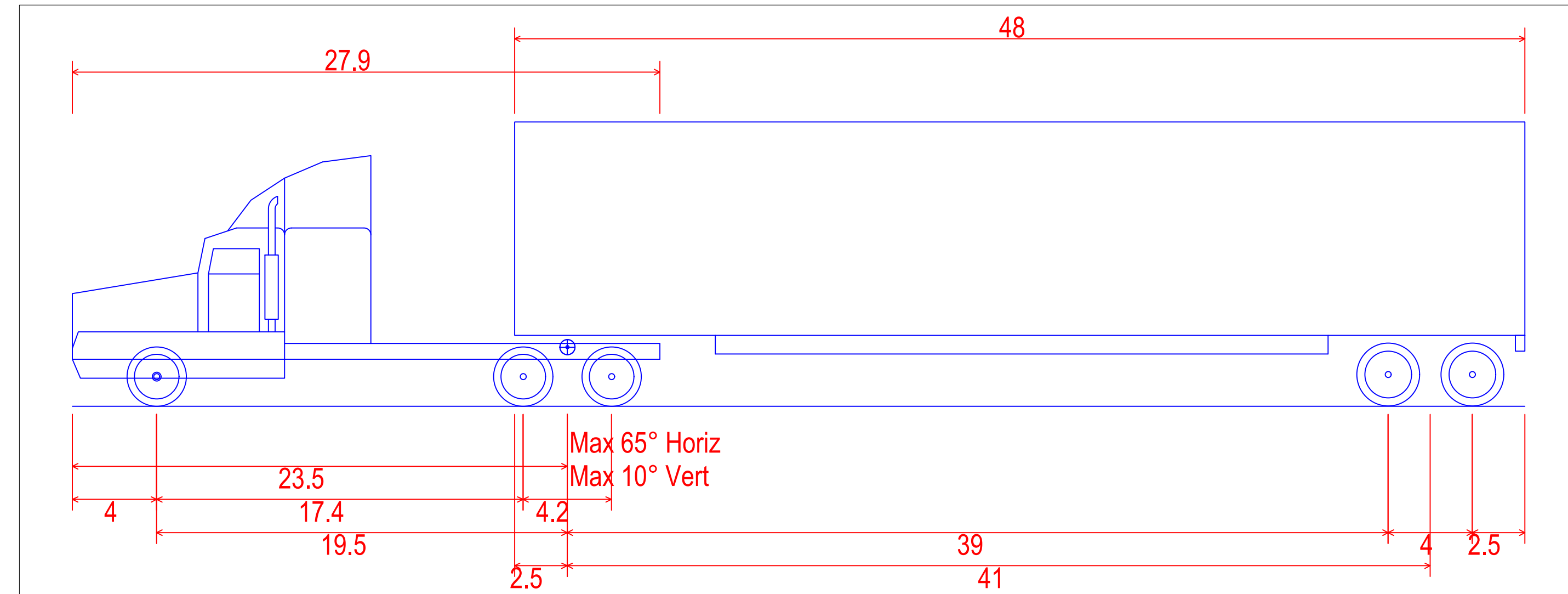
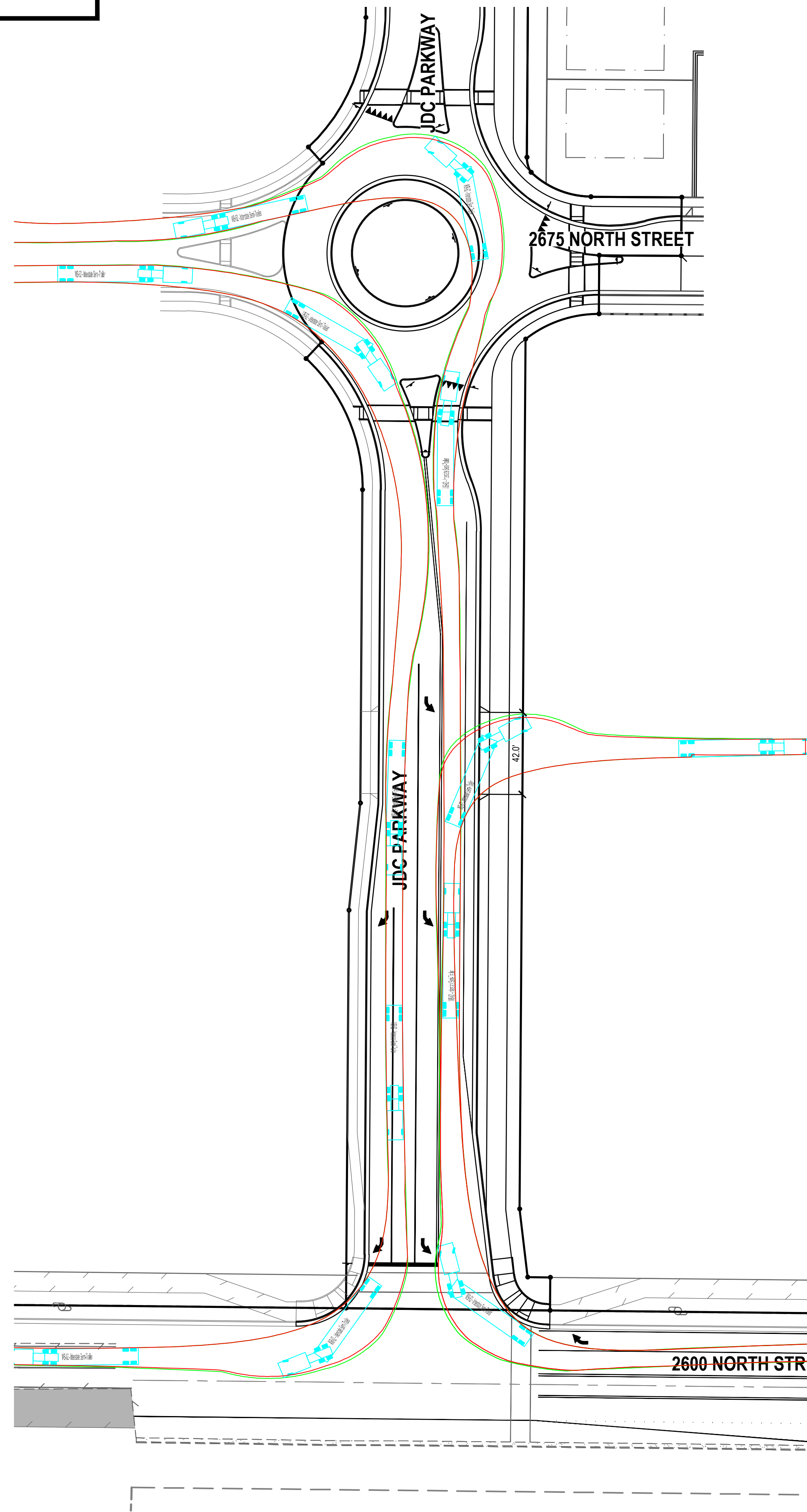

WB-62 - Interstate Semi-Trailer
 Overall Length **69.00ft**
 Overall Width **8.50ft**
 Overall Body Height **13.50ft**
 Min Body Ground Clearance **1.334ft**
 Max Track Width **8.50ft**
 Lock-to-lock time **6.00s**
 Max Steering Angle (Virtual) **28.40°**

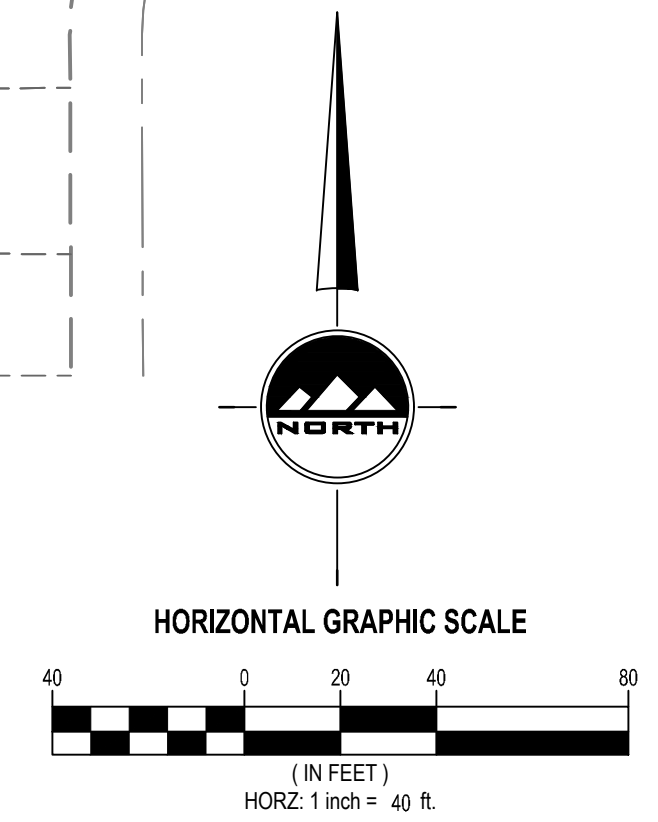

LAYTON
919 North 400 West
Layton, UT 84041
Phone: 801.547.1100

SANDY
Phone: 801.255.0529

TOOELE
Phone: 435.843.3590

CEDAR CITY
Phone: 435.865.1453

RICHFIELD
Phone: 435.896.2983

WWW.ENSIGNENG.COM

FOR:
NILSON HOMES
1740 COMBE RD, SUITE 2
SOUTH OGDEN, UT 84403

CONTACT:
STEVE ANDERSON
PHONE: 801.392.8100

JDC PARKWAY
2800 WEST 2600 NORTH STREET
WEBER COUNTY, UTAH

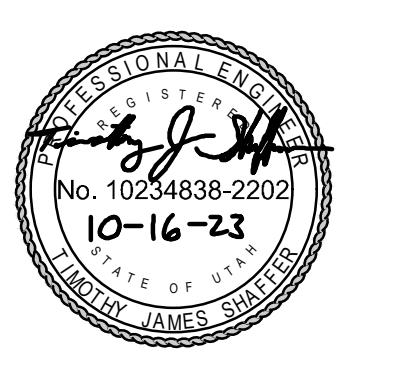

NO. DATE REVISION FOR REVIEW

**WB-62 SEMI TRUCK
VEHICLE TRACKING
EXHIBIT**

PROJECT NUMBER 9872
PROJECT MANAGER CP
PRINT DATE 2023-10-16
DESIGNED BY TS

EX-2