



# Land Use Permit

## Weber County Planning Commission

2380 Washington Blvd. STE 240

Ogden, UT 84401

Phone: (801) 399-8791 FAX: (801) 399-8862

webercountyutah.gov/planning

**Permit Number: LUP277-2023**

Permit Type: Structure

Permit Date: 09/01/2023

### Applicant

**Name:** Karlie Kier  
**Business:**  
**Address:** 2715 E 6000 S  
, UT  
**Phone:** 801-991-0434

### Owner

**Name:**  
**Business:**  
**Address:** , UT  
**Phone:**

### Parcel

**Parcel:** 071740002

**Zoning:** RE-20 **Area:** .4576 **Sq Ft:**  
**Address:** 2715 E 6000 S OGDEN, UT 84403

**Lot(s):** 2

**Subdivision:** Raintree Subdivision  
**T - R - S - QS:** 5N - 1W - 23 -

### Proposal

**Proposed Structure:** Fence  
**Proposed Structure Height:** 6  
**# of Dwelling Units:**  
**# Off Street Parking Req'd:**

**Building Footprint:**  
**Max Structure Height in Zone:** 6  
**# of Accessory Bldgs:**  
**\*Is Structure > 1,000 Sq. Ft?** N/A  
**\*If True Need Certif. Statement**

### Permit Checklist

**Access Type:** Front lot line  
**Greater than 4218 ft above sea level?** Yes  
**Additional Setback Req'd. ?** N/A  
**> 200 ft from paved Road?** N/A  
**Culinary Water District:**

**Alternative Access File #**  
**Wetlands/Flood Zone?** N/A  
**Meet Zone Area Frontage?** Yes  
**Hillside Review Req'd?** N/A  
**Waste Water System:**

### Comments

Permit issued for a fence not exceeding 6 ft in height.

# Land Use Permit

## Structure Setback Graphic: Barn, Corral, or Stable

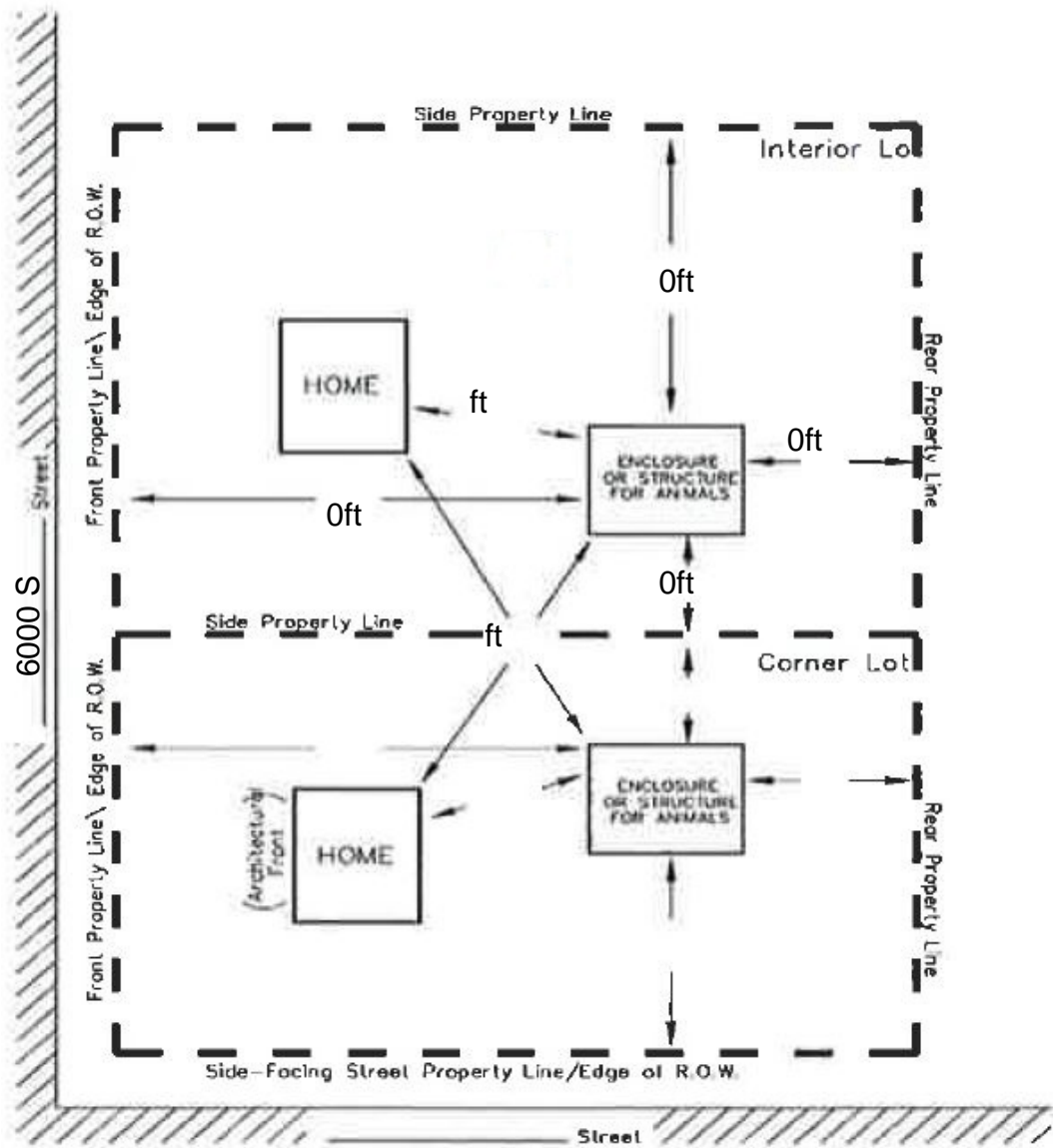

## MINIMUM YARD SETBACKS Barn, Corral, or Stable

### NOTICE FOR APPLICANT (Please Read Before Signing)

Proposals for the installation of an individual water supply and for a sanitary waste disposal system (septic tank) for any structure designed for human occupation must be approved by Weber County Health Department prior to installation.

**Marta Borchert**

**09/01/2023**

Planning Dept. Signature of Approval

Date

I hereby certify that I have read and examined this application and know the same to be true and correct. All provisions of laws and ordinances governing this land use will be complied with whether specified herein or not. I make this statement under penalty of perjury.

Contractor/Owner Signature of Approval

Date