

# Walter House Subdivision

Weber County, Utah  
A Part of the Southeast Quarter of Section 7,  
Township 6 North, Range 2 West, Salt Lake Base & Meridian  
March 2021

### NARRATIVE

The purpose of this survey was to establish and set the property corners of the one lot Subdivision as shown and described hereon. This survey was ordered by Doug Hansen. The control used to establish the property corners was the Waterfront Property Management Subdivision to the north and the Fenster Farm Subdivision to the south along with the existing Weber County Surveyor Monumentation surrounding Section 7, Township 6 North, Range 2 West, S.L.B.&M. The basis of bearing is the west line of the Southeast Quarter of said Section which bears South 00°18'53" West, Utah North, State Plane, Calculated N.A.D.83 Bearing.

### AGRICULTURAL NOTE

Agriculture is the preferred use in the Agriculture Zones. Agriculture operations as specified in the zoning ordinance for a particular zone are permitted at any time including the operation of farm machinery and no allowed agriculture use shall be subject to restriction on that it interferes with activities of future residents of this subdivision.

### WEBER COUNTY ENGINEER

I Herby Certify that the Required Public Improvement Standards and Drawings for this Subdivision Conform with the County Standards and the Amount of the Financial Guarantee is Sufficient for the Installation of these Improvements.

Signed this \_\_\_\_\_ Day of \_\_\_\_\_, 2023.

\_\_\_\_\_  
Weber County Engineer

### WEBER COUNTY PLANNING COMMISSION APPROVAL

This is to Certify that this Subdivision Plat was Duly

Approved by the Weber County Planning Commission.

Signed this \_\_\_\_\_ Day of \_\_\_\_\_, 2023.

\_\_\_\_\_  
Chairman, Weber County Planning Commission

### NOTE:

- 1 - All public utility easements (P.U.E.) are 10.0 foot wide unless otherwise noted.
- 2 - Rebar and cap set on all corners as shown hereon.
- 3 - Cullinary Water to be provided by \_\_\_\_\_ Water Co.
- 4 - Sewer System to be Individual Septic Systems approved by the Weber - Morgan Health Dept.
- 5 - Existing Shed near North Boundary of Lot 1 can be considered temporary and removable - If removed, the area reverts to be part of adjoining Access Easement.
- 6 - Due to the topography and the location of this subdivision all owners will accept responsibility for any storm water runoff from the road adjacent to this property until curb and gutter is installed.

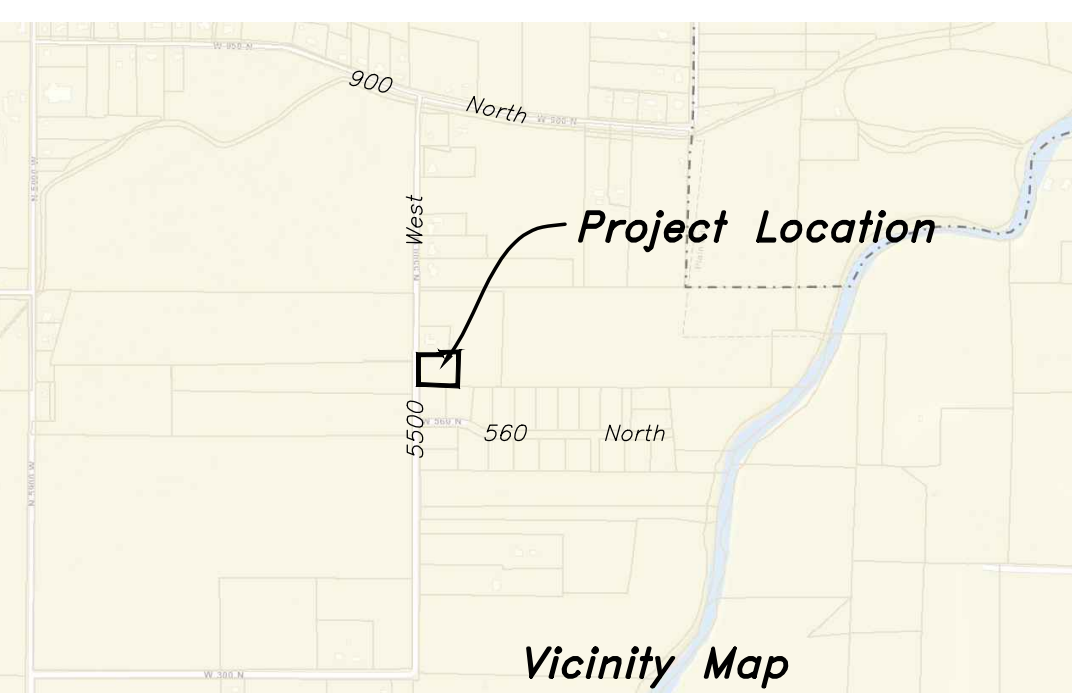

Developer:  
Doug Hansen  
164 S 3600 W  
Ogden, Utah 84404  
(801) 710-1062



**HANSEN & ASSOCIATES, INC.**  
Consulting Engineers and Land Surveyors  
538 North Main Street, Brigham, Utah 84302  
Visit us at [www.haies.net](http://www.haies.net)  
Brigham City Ogden Logan  
(435) 723-3491 (801) 399-4905 (435) 752-8272  
Celebrating over 60 Years of Business

Northwest of the Southeast Quarter of Sec. 7, T. 6 N., R. 2 W., S.L.B.&M. Found Weber County 3" Brass Cap Monument in buried 6" dated 1963 in good condition.

### REMAINING PARCEL BOUNDARY DESCRIPTION

A PART OF THE SOUTHEAST QUARTER OF SECTION 7, TOWNSHIP 6 NORTH, RANGE 2 WEST OF THE SALT LAKE BASE AND MERIDIAN.

BEGINNING AT THE NORTHWEST CORNER OF WATERFRONT PROPERTY MANAGEMENT SUBDIVISION FILED AS ENTRY NO. 2734879 IN THE FILES OF THE WEBER COUNTRY RECORDER LOCATED 240.84 FEET SOUTH 00°18'53" WEST ALONG THE WEST LINE OF SAID SOUTHEAST QUARTER FROM THE NORTHWEST CORNER OF SAID SOUTHEAST QUARTER;

RUNNING THENCE NORTH 00°18'53" EAST 178.95 FEET; THENCE SOUTH 89°20'18" EAST 625.94 FEET TO AN EXISTING FENCE LINE; THENCE SOUTH 03°24'06" WEST 621.70 FEET (622.37 FEET BY RECORD) ALONG AN EXISTING FENCE LINE TO AN EXISTING FENCE CORNER BEING THE NORTH BOUNDARY LINE OF FENSTER FARM SUBDIVISION PHASE 2 FILED AS ENTRY NO. 3034872 IN THE FILES OF THE WEBER COUNTRY RECORDER; THENCE ALONG AN EXISTING FENCE LINE AND SAID NORTH BOUNDARY LINE OF SAID FENSTER FARM SUBDIVISION PHASE 2 THE FOLLOWING TWO COURSES; (1) NORTH 89°24'27" WEST 58.32 FEET; AND (2) NORTH 89°42'59" WEST 124.46 FEET TO THE NORTHEAST CORNER OF FENSTER FARM SUBDIVISION PHASE 1 FILED AS ENTRY NO. 2676340 IN THE FILES OF THE WEBER COUNTRY RECORDER; THENCE ALONG THE NORTH BOUNDARY LINE OF SAID FENSTER FARM SUBDIVISION NORTH 89°24'27" WEST 48.27 FEET; THENCE NORTH 00°18'53" EAST 271.13 FEET; THENCE NORTH 88°04'00" WEST 115.59 FEET TO THE SOUTHWEST CORNER OF SAID WATERFRONT PROPERTY MANAGEMENT SUBDIVISION; THENCE ALONG THE BOUNDARY LINE OF SAID SUBDIVISION THE FOLLOWING THREE (3) COURSES; (1) NORTH 00°22'55" EAST 40.11 FEET; (2) NORTH 07°47'07" EAST 131.86 FEET; AND (3) NORTH 89°41'46" WEST 263.05 FEET TO THE POINT OF BEGINNING. CONTAINING 5.44 ACRES.

### Access, Drainage, and Utility Easement Description

AN ACCESS, DRAINAGE, AND UTILITY EASEMENT NORTH OF THE FOLLOWING DESCRIBED ALIGNMENT, EXCEPTING THE EXISTING SHED AS SHOWN HEREON, SITUATED IN THE SOUTHEAST QUARTER OF SECTION 7, TOWNSHIP 6 NORTH, RANGE 2 WEST OF THE SALT LAKE BASE AND MERIDIAN, MORE PARTICULARLY DESCRIBED AS FOLLOWS.

BEGINNING AT A POINT LOCATED 427.28 FEET SOUTH 00°18'53" WEST ALONG THE WEST LINE OF SAID SOUTHEAST QUARTER AND 33.00 FEET SOUTH 89°41'07" EAST TO THE SOUTHWEST CORNER OF THE WATERFRONT PROPERTY MANAGEMENT SUBDIVISION FILED AS ENTRY NO. 2734879 IN THE FILES OF THE WEBER COUNTRY RECORDER AND 17.75 FEET SOUTH 00°18'53" WEST FROM THE NORTHWEST CORNER OF SAID SOUTHEAST QUARTER;

RUNNING THENCE SOUTH 89°41'07" EAST 94.46 FEET; THENCE SOUTH 75°25'22" EAST 118.22 FEET; THENCE NORTH 74°48'28" EAST 85.51 FEET THENCE NORTH 87°39'00" EAST 37.01 FEET TO THE WEST LINE OF DOUGLAS AND CAROLYN HANSEN PROPERTY, TAX ID. NO. 15-024-0018 BEING THE POINT OF TERMINUS.

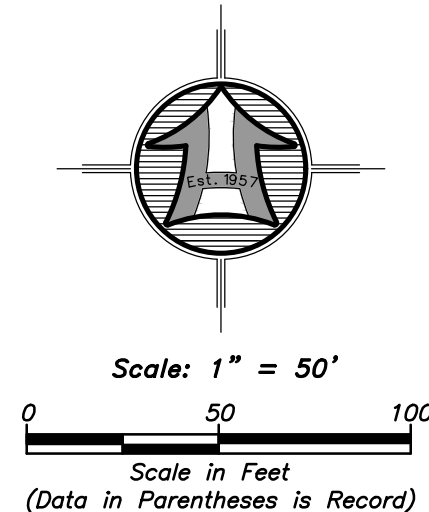

### LEGEND

- Subject Property Line
- - - Interior Lot Lines
- - - Adjoining Property Line
- - - Previous Property Line
- - - Centerline
- - - Public Utility Easement (PUE)
- - - Ditch
- - - Field Separation Line
- - - Fence Line (Wire)
- - - Road Dedication
- - - Easement
- Street Monument to be set
- Found rebar set by others
- Set 5/8"x24" Rebar With Cap
- Section Corner

South Quarter Corner of Sec. 7, T. 6 N., R. 2 W., S.L.B.&M. Found Weber County 3" Brass Cap Monument dated 1981 in fair condition.

### WEBER COUNTY COMMISSION ACCEPTANCE

This is to Certify that this Subdivision Plat, the Dedication of Streets and other Public Ways and Financial Guarantee of Public Improvements Associated with this Subdivision, Thereon are Herby Approved and Accepted by the Commissioners of Weber County Utah

Signed this \_\_\_\_\_ Day of \_\_\_\_\_, 2023.

\_\_\_\_\_  
Chairman, Weber County Commission

Affest

### WEBER COUNTY SURVEYOR

I Herby Certify that the Weber County Surveyor's Office has Reviewed this Plat and all conditions for approval by this office have been satisfied. The approval of this Plat by the Weber County Surveyor does not relieve the Licensed Land Surveyor who executed this plat from the responsibilities and/or liabilities associated therewith.

Signed this \_\_\_\_\_ Day of \_\_\_\_\_, 2023.

\_\_\_\_\_  
Weber County Surveyor

### WEBER COUNTY ATTORNEY

I Have Examined the Financial Guarantee and Other Documents Associated with this Subdivision Plat, and in my Opinion they Conform with the County Ordinance Applicable Thereto and now in Force and Affect

Signed this \_\_\_\_\_ Day of \_\_\_\_\_, 2023.

\_\_\_\_\_  
Weber County Attorney

### WEBER-MORGAN HEALTH DEPARTMENT

I Herby Certify that the Soils, Percolation Rates, and Site Conditions for this Subdivision have been Investigated by this Office and are Approved for On-Site Wastewater Disposal Systems.

Signed this \_\_\_\_\_ Day of \_\_\_\_\_, 2023.

\_\_\_\_\_  
Weber-Morgan Health Department

### SURVEYOR'S CERTIFICATE

I, K. Greg Hansen, do hereby certify that I am a Registered Professional Land Surveyor in the State of Utah in Accordance with Title 58, Chapter 22, Professional Engineers and Professional Land Surveyors Act; and I have completed a survey of the property described on this plat in accordance with Section 17-23-17 and have verified all measurements, and have placed monuments as represented on this plat, and have hereby Subdivided said tract into a lot, known hereafter as Walter House Subdivision in Weber County, Utah, and has been correctly drawn to the designated scale and is true and correct representation of the herein described lands included in said Subdivision, based upon data compiled from records in the Weber County Recorder's Office and from said survey made by me or under my supervision on the ground, I further hereby certify that the requirements of all applicable statutes and ordinances of Weber County Concerning Zoning Requirements regarding lot measurements have been complied with.

Signed this \_\_\_\_\_ day of \_\_\_\_\_, 2023.

K. Greg Hansen P.L.S.  
Utah Land Surveyor License No. 167819



### BOUNDARY DESCRIPTION

A PART OF THE SOUTHEAST QUARTER OF SECTION 7, TOWNSHIP 6 NORTH, RANGE 2 WEST OF THE SALT LAKE BASE AND MERIDIAN.

BEGINNING AT THE NORTHWEST CORNER OF FENSTER FARM SUBDIVISION PHASE 1 FILED AS ENTRY NO. 2676340 IN THE FILES OF THE WEBER COUNTRY RECORDER LOCATED 684.28 FEET SOUTH 00°18'53" WEST ALONG THE WEST LINE OF SAID SOUTHEAST QUARTER FROM THE NORTHWEST CORNER OF SAID SOUTHEAST QUARTER;

RUNNING THENCE NORTH 00°18'55" EAST 257.00 FEET TO THE SOUTHWEST CORNER OF THE WATERFRONT PROPERTY MANAGEMENT SUBDIVISION FILED AS ENTRY NO. 2734879 IN THE FILES OF THE WEBER COUNTRY RECORDER; THENCE ALONG THE BOUNDARY LINE OF SAID WATERFRONT PROPERTY MANAGEMENT SUBDIVISION THE FOLLOWING THREE (3) COURSES; (1) SOUTH 89°41'07" EAST 195.75 FEET; (2) NORTH 01°16'39" EAST 17.06 FEET; AND (3) SOUTH 88°04'00" EAST 165.42 FEET; THENCE SOUTH 00°18'53" WEST 271.13 FEET TO THE NORTH BOUNDARY LINE OF SAID FENSTER FARM SUBDIVISION PHASE 1; THENCE ALONG SAID NORTH BOUNDARY LINE NORTH 89°24'31" WEST 361.39 FEET TO THE POINT OF BEGINNING. CONTAINING 2.195 ACRES. SUBJECT TO A 8.25 FOOT WIDE ACCESS EASEMENT AS DESCRIBED ON THE ABOVE DESCRIBED WATERFRONT PROPERTY MANAGEMENT SUBDIVISION.

### OWNER'S DEDICATION AND CERTIFICATION

We the undersigned owners of the herein described tract of land, do hereby set apart and subdivide the same into a lot and streets as shown hereon and name said tract Walter House Subdivision, and do hereby: Dedicate to public use all those parts or portions of said tract of land designated as 5500 West Street, the same to be used as public thoroughfares. We also hereby grant and dedicate to the public the public utility easement along the frontage of 5500 West Street. We also dedicate the private access, drainage, and utility easement as shown hereon for the benefit of the Remainder Parcel. Said easements are to be used for the installation, maintenance, and operation of public and private utility service lines, and encompass provisions for storm drainage and irrigation facilities. No buildings or structures are to be erected within such easements. Plat notes shown hereon are hereby declared to be effective and binding.

Signed this \_\_\_\_\_ day of \_\_\_\_\_, 2023.

\_\_\_\_\_  
Douglas L. Hansen

\_\_\_\_\_  
Carolyn D. Hansen

### ACKNOWLEDGMENT

STATE OF UTAH )  
COUNTY OF WEBER )

On this \_\_\_\_\_ day of \_\_\_\_\_, 2023, Douglas L. Hansen and Carolyn D. Hansen, Husband and Wife as Joint Tenants, personally appeared before me, the undersigned Notary Public in and for said County of Weber, in the State of Utah, the signers of the attached Owners Dedication, two in numbers, who duly acknowledged to me they signed it freely and voluntarily and for the purpose therein mentioned.

\_\_\_\_\_  
Notary Public

### WEBER COUNTY RECORDER

ENTRY NO. \_\_\_\_\_ FEE PAID \_\_\_\_\_ FILED FOR RECORD AND

RECORDED \_\_\_\_\_

\_\_\_\_\_ IN BOOK \_\_\_\_\_ OF OFFICIAL

RECORDS, PAGE \_\_\_\_\_ RECORDED

FOR \_\_\_\_\_

\_\_\_\_\_ COUNTY RECORDER

BY: \_\_\_\_\_ DEPUTY