



Land Use Permit

Weber County Planning Commission

2380 Washington Blvd. STE 240

Ogden, UT 84401

Phone: (801) 399-8791 FAX: (801) 399-8862

webercountyutah.gov/planning

Permit Number: LUP171-2023

Permit Type: Structure

Permit Date: 07/11/2023

Applicant

Name: Clint Menke
Business: Rocking HR Ranches LLC
Address: 10251 E Hwy 39
Huntsville, UT 84317
Phone: 801-389-2006

Owner

Name:
Business: Rocking HR Ranches, LLC
Address: 10251 E Hwy 39
Huntsville, UT 84317
Phone: 801-389-2006

Parcel

Parcel: 210210009

Zoning: FV-3 **Area:** 111.79 **Sq Ft:**
Address: 10251 Hwy 39 Huntsville, UT 84317

Lot(s): N/A **Subdivision:** N/A
T - R - S - QS: 6N - 2E - 15 - NE

Proposal

Proposed Structure: Ag shed

Proposed Structure Height: 29

of Dwelling Units: 0

Off Street Parking Reqd: 0

Building Footprint: 7200

Max Structure Height in Zone: 35

of Accessory Bldgs: 0

***Is Structure > 1,000 Sq. Ft?** Yes

*If True Need Certif. Statement

Permit Checklist

Access Type: Front Lot Line

Greater than 4218 ft above sea level? Yes

Additional Setback Reqd. ? No

> 200 ft from paved Road? Yes

Culinary Water District: N/A

Alternative Access File #

Wetlands/Flood Zone? No

Meet Zone Area Frontage? Yes

Hillside Review Reqd? No

Waste Water System: N/A

Comments

Ag-exempt structure for the purposes of storing hay and ag machinery. Minimum setbacks for a main building (ag is the main use on this parcel) are: front/rear - 30', side - 20'. Max height is 35', proposed height is 29' from finished grade.

Land Use Permit

Structure Setback Graphic: Barn, Corral, or Stable

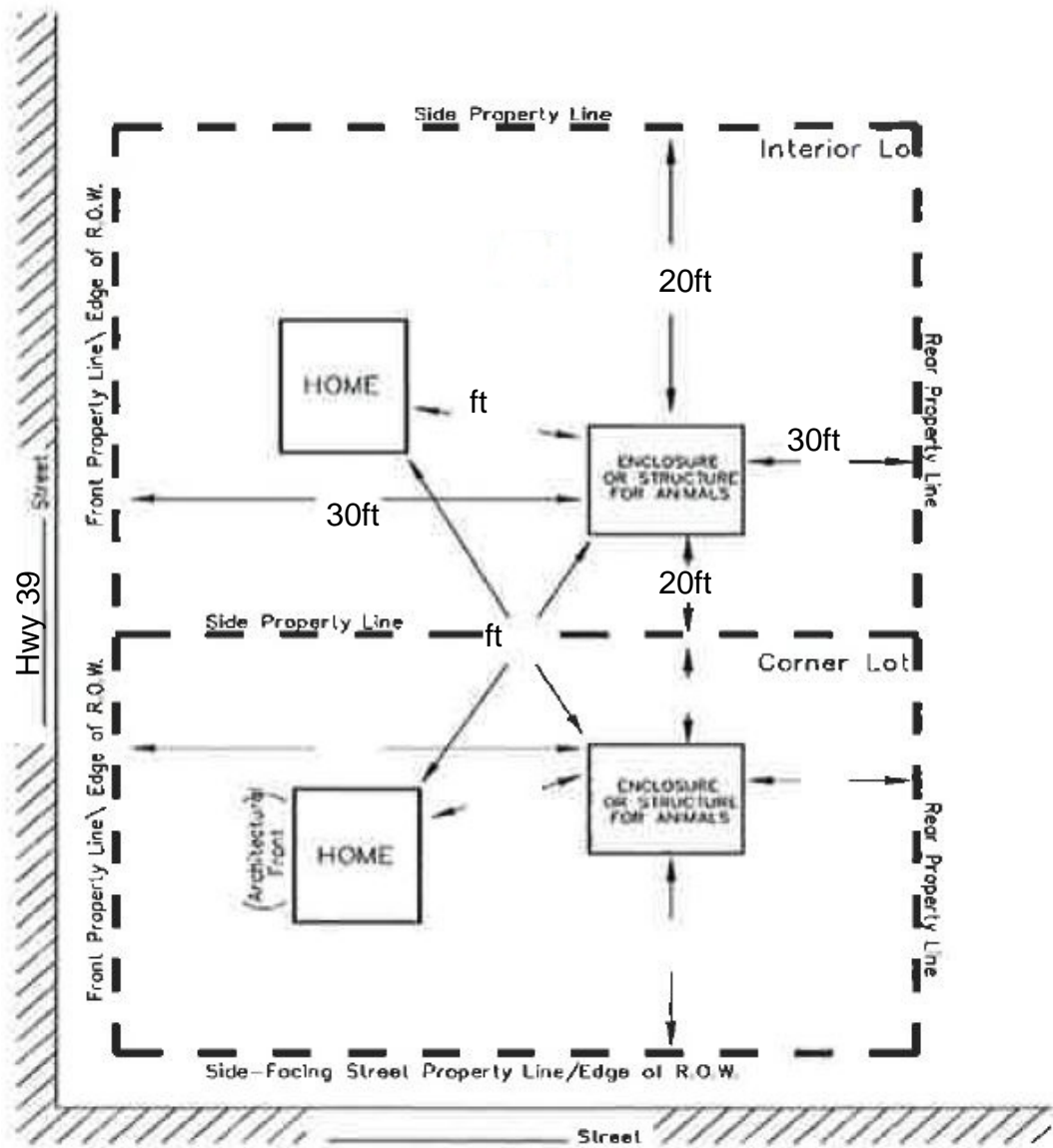

MINIMUM YARD SETBACKS Barn, Corral, or Stable

NOTICE FOR APPLICANT (Please Read Before Signing)

Proposals for the installation of an individual water supply and for a sanitary waste disposal system (septic tank) for any structure designed for human occupation must be approved by Weber County Health Department prior to installation.

Tammy Aydelotte

07/11/2023

Planning Dept. Signature of Approval

Date

I hereby certify that I have read and examined this application and know the same to be true and correct. All provisions of laws and ordinances governing this land use will be complied with whether specified herein or not. I make this statement under penalty of perjury.

Contractor/Owner Signature of Approval

Date