



OGDEN VALLEY PLANNING COMMISSION

MEETING AGENDA

October 6, 2015

5:00 p.m.

*Pledge of Allegiance*

*Roll Call:*

1. Consent Agenda:
  - 1.1. DR 2015-08 Consideration and action for a design review amendment for the commercial building located at 4930 East 2550 North in the Commercial Valley (CV-2) Zone (Justin Pack Agent for Dog and Bone, LLC)
  - 1.2. CUP 2015-08 Consideration and action for a conditional use permit for the LPC Lomondi Well, a culinary well and associated pump house, as an expansion of the Liberty Pipeline Company culinary water system located at approximately 6649 N. North Fork Road in the Forest (F-5) Zone (Mike Durtschi, Project Engineer – Gardner Engineering)
2. Public Comment for Items not on the Agenda
3. Remarks from Planning Commissioners
4. Planning Director Report
5. Remarks from Legal Counsel
6. Adjourn

*The regular meeting will be held in the Weber County Commission Chambers, in the Weber Center, 1<sup>st</sup> Floor, 2380 Washington Blvd., Ogden, Utah. No Pre-Meeting will be held.*

***Please enter the building through the front door on Washington Blvd. if arriving to the meeting after 5:00 p.m.***

***In compliance with the Americans with Disabilities Act, persons needing auxiliary services for these meetings should call the Weber County Planning Commission at 801-399-8791***



## Staff Report to the Ogden Valley Planning Commission

Weber County Planning Division

### Synopsis

#### Application Information

<b>Application Request:</b>	Consideration and action for a design review amendment for the commercial building located at 4930 East 2550 North Eden, Utah
<b>Type of Decision:</b>	Administrative
<b>Agenda Date:</b>	Tuesday, October 06, 2015
<b>Applicant:</b>	Dog and Bone, LLC
<b>Authorized Agent:</b>	Justin Pack
<b>File Number:</b>	DR# 2015-08

#### Property Information

<b>Approximate Address:</b>	4930 East 2550 North Eden, UT
<b>Project Area:</b>	0.98 Acres
<b>Zoning:</b>	Commercial Valley-2 (CV-2)
<b>Existing Land Use:</b>	Vacant
<b>Proposed Land Use:</b>	Commercial Development
<b>Parcel ID:</b>	22-158-0006 & 22-158-0007
<b>Township, Range, Section:</b>	Township 7 North, Range 1 East, Section 34

#### Adjacent Land Use

<b>North:</b>	Commercial	<b>South:</b>	Commercial
<b>East:</b>	Commercial	<b>West:</b>	Commercial

#### Staff Information

<b>Report Presenter:</b>	<b>Ronda Kippen</b> rkippen@co.weber.ut.us 801-399-8768
<b>Report Reviewer:</b>	JG

### Applicable Ordinances

- Title 101, Chapter 1, General Provisions, Section 7, Definitions
- Title 104, Chapter 21 Commercial Valley Zones (CV-2)
- Title 104, Chapter 28, Ogden Valley Sensitive Lands Overlay Districts
- Title 104, Chapter 1 Design Review
- Title 104, Chapter 2 Ogden Valley Architectural, Landscape and Screening Design Standards

### Summary and Background

The applicant is requesting to amend the exterior color and architectural detail of the commercial building that was approved by the Ogden Valley Planning Commission on February 24, 2015 as part of the required design review for a conditionally permitted auto repair and service shop. During the construction process, the property owner has opted to make some improvements to the original design which includes eliminating the painted brick exterior and the wood siding along the side and rear. The new design utilizes a gabled false front parapet instead of a step false front parapet with "Autumn Blend" brick for the exterior finish.

The proposed application has been reviewed against certain standards in the Uniform Land Use Code of Weber County, Utah (LUC) and appears to meet these standards. The following is staff's evaluation of the request.

## Analysis

*Design Review:* The commercial zone mandates a design review as outlined in LUC §108-1 to ensure that the general design, layout and appearance of the building remains orderly and harmonious with the surrounding neighborhood. Certain areas of the design review are only applicable to the current amendment application, such as the building and site layout. As part of this review, the Planning Commission shall consider the applicable matters based on the proposed amendment and impose conditions to mitigate deficiencies where the plan is found deficient. The matters for consideration are as follows:

- *Considerations relating to traffic safety and traffic congestion.* The previously approved “Complete Street” design will be asphalted, utilizing old-fashioned parking curbs. Prior to installing the parking curbs, the applicant will need to consult with Engineering Division to ensure adequate safety measures have been taken.
- *Considerations relating to buildings and site layout.* The proposal modifies the exterior finish of brick and wood siding to entirely brick and has been modified from a step false front parapet to a gabled false front parapet (see Exhibit A and B). The exterior color will be “Autumn Blend” (see Exhibit C) which is considered a natural, muted earth tone with contrasting accent colors of red, black and white. All of the windows in the building and the overhead glass doors along the front of the building will be non-reflective glass; the rear overhead doors will be white with non-reflective windows.

## Conformance to the General Plan

The proposed use conforms to the Ogden Valley General Plan by encouraging commercial development within established commercial areas and enforcing the adopted “quality development standards” to ensure compatibility with the Valley’s character.

## Staff Recommendation

The Planning Division recommends approval of file# DR2015-08, a design review amendment for the commercial building located at 4930 East 2550 North Eden, Utah. This recommendation for approval is subject to all review agency requirements and with the following conditions:

1. Requirements of the Weber County Building Inspection Division
2. Requirements of the Weber County Engineering Division

This recommendation is based on the following findings:

1. The proposed use conforms to the Ogden Valley General Plan.
2. The proposed use will provide a necessary service to the citizens of the Ogden Valley.
3. The “Complete Street” design will provide safe mobility for all users.
4. The proposed use, if conditions are imposed, will not be detrimental to the public health, safety, or welfare.
5. The proposed use, if conditions are imposed, will comply with applicable County ordinances.
6. The proposed design and use, including the option to have overhead doors in each unit or every other unit, will not deteriorate the environment of the general area so as to negatively impact surrounding properties and uses.

## Exhibits

- A. Original Architectural Renderings
- B. Proposed Architectural Renderings
- C. Brick Photo



Map 1



Map 2



Exhibit A- Original Architectural Renderings

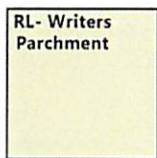
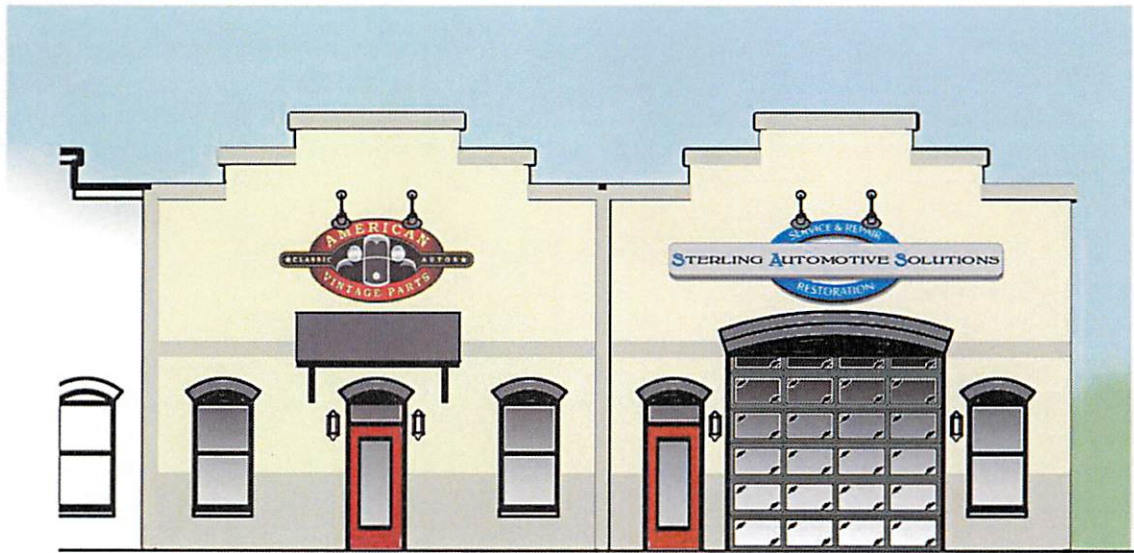

RL- Writers  
Parchment  
Painted Brick  
Siding

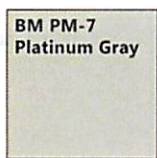

BM PM-7  
Platinum Gray  
Painted Banding  
on brick,  
Conc. Caps



BM PM-9  
Black  
Door casings  
Window casings  
Windows



BM PM-18  
Heritage Red  
All Pedestian  
Doors

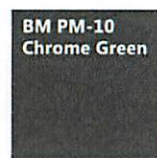

BM PM-10  
Chrome Green  
All Garage Doors



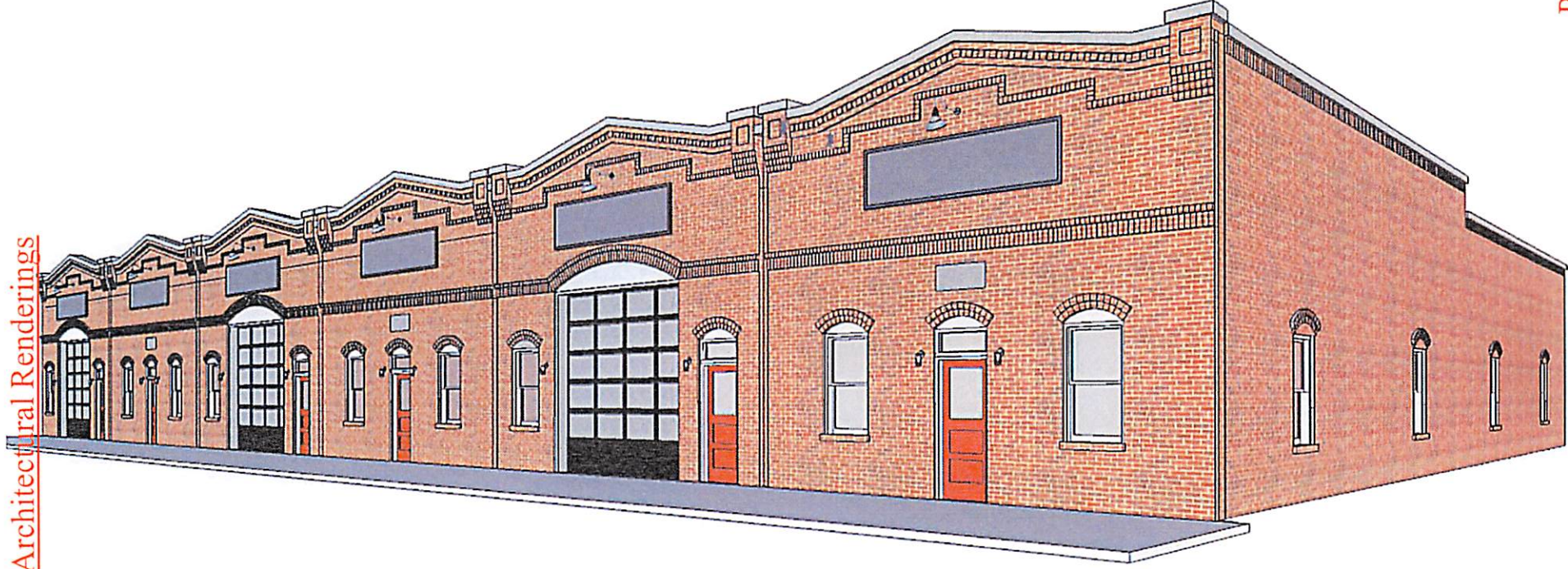





Exhibit B- Proposed Architectural Renderings

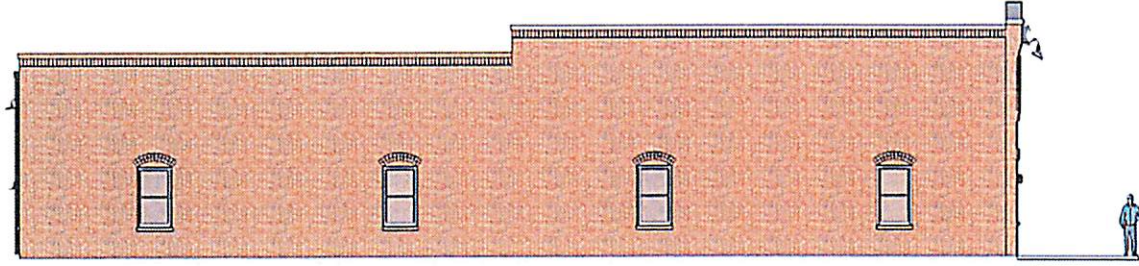
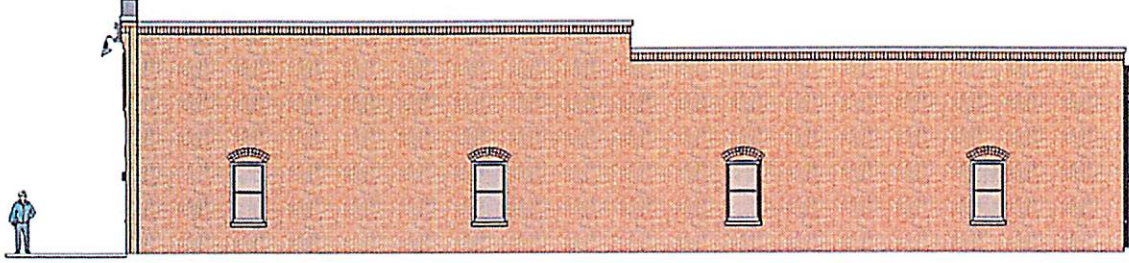



Exhibit C- Brick Photos

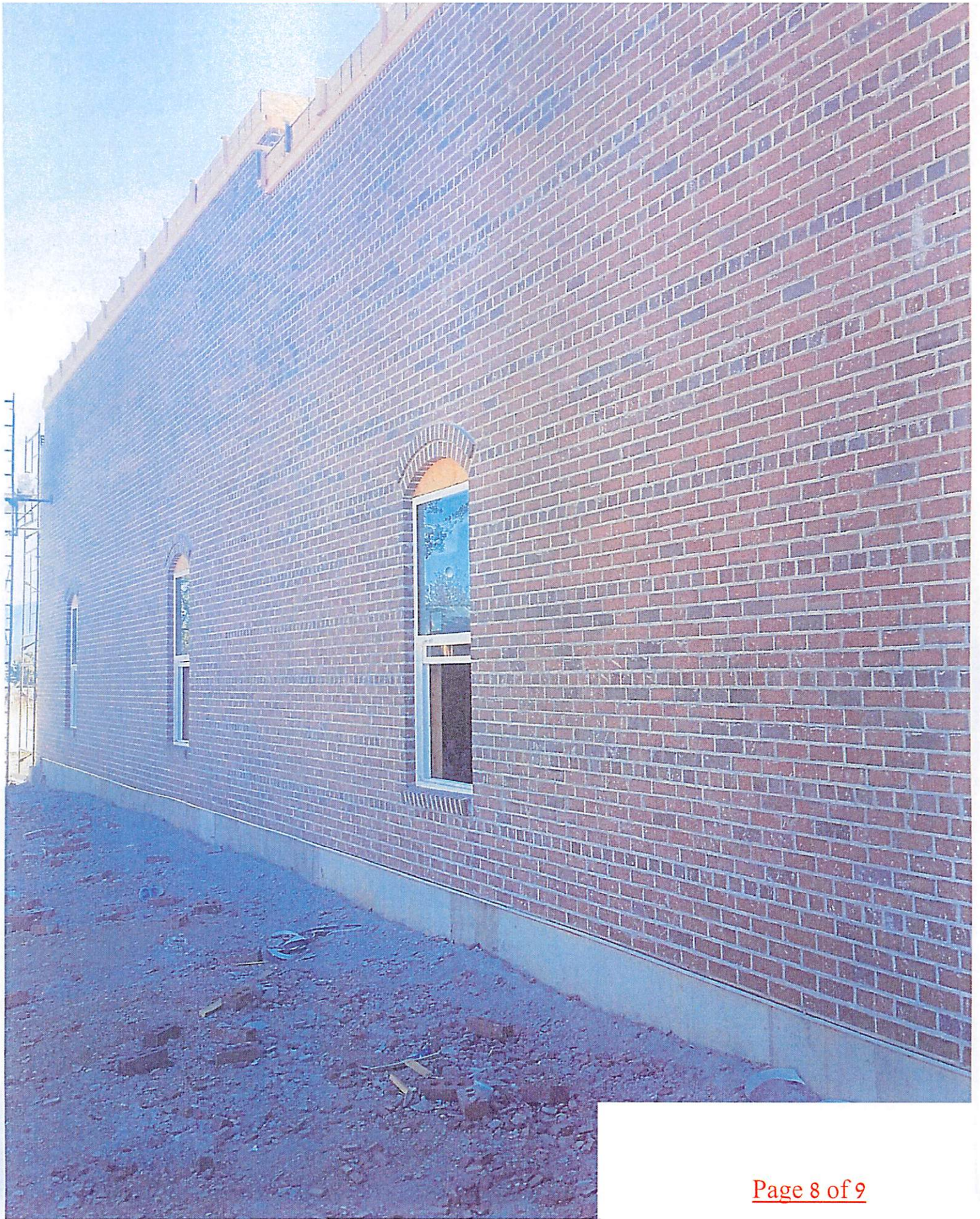
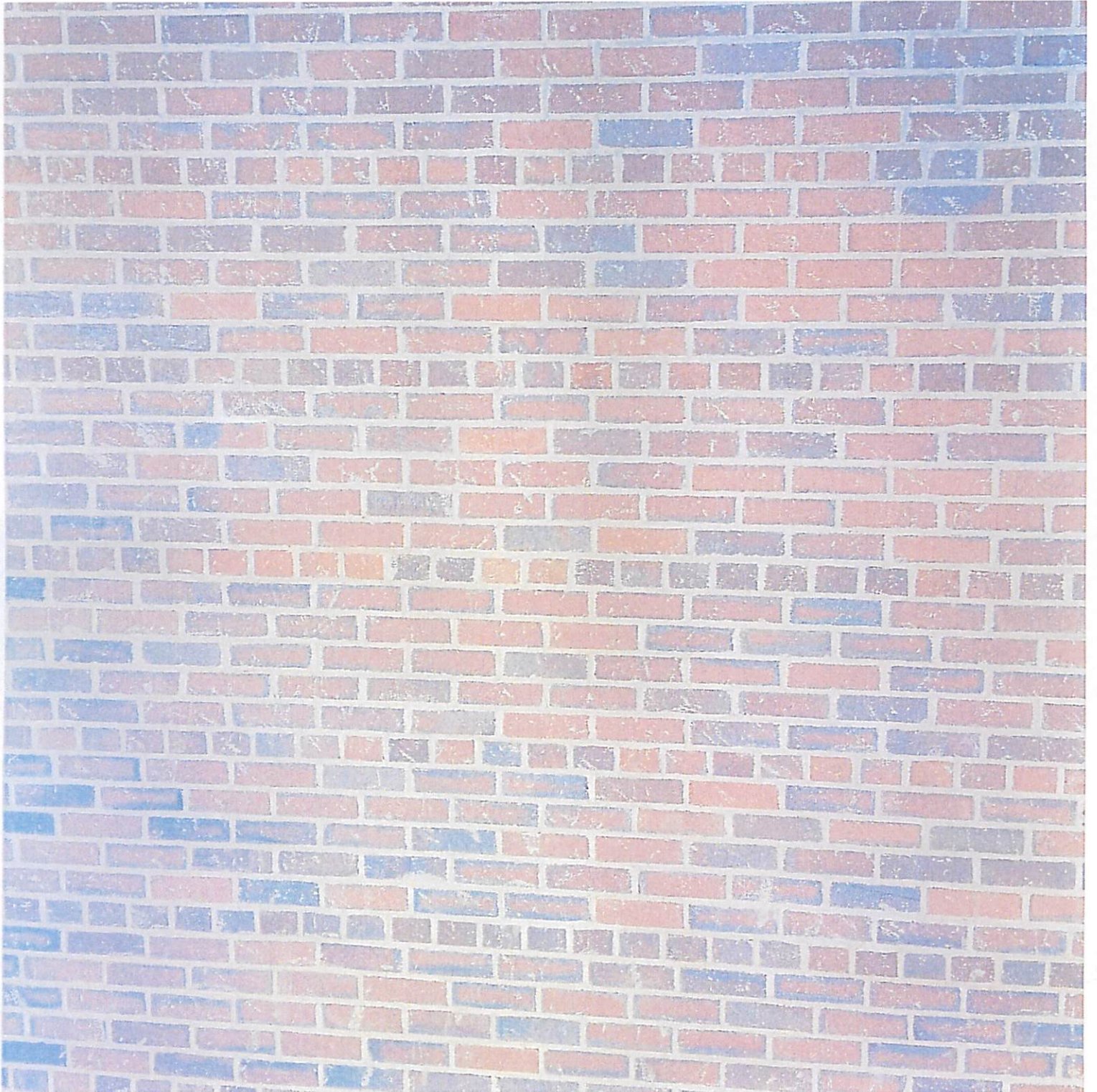



Exhibit C- Brick Photos







# Staff Report to the Ogden Valley Planning Commission

Weber County Planning Division

## Synopsis

### Application Information

**Application Request:** Consideration and action for a conditional use permit for the LPC Lomondi Well, a culinary well and associated pump house, as an expansion of the Liberty Pipeline Company culinary water system.

**Type of Decision:** Administrative

**Agenda Date:** Tuesday, October 06, 2015

**Applicant:** Mount Ogden State of the Church of Jesus Christ of Latter Day Saints in agreement with Liberty Pipeline Company

**Authorized Agent:** Mike Durtschi, project engineer (Gardner Engineering)

**File Number:** CUP# 2015-08

### Property Information

**Approximate Address:** 6649 N. North Fork Road, Liberty, UT

**Project Area:** 23,682 sq ft (0.5436 acres)

**Zoning:** Forest Zone (F-5)

**Existing Land Use:** Private campground

**Proposed Land Use:** Culinary Well and Pump House

**Parcel ID:** 16-001-0005

**Township, Range, Section:** Township 7 North, Range 1 West, Section 1

### Adjacent Land Use

<b>North:</b>	Forest Residential	<b>South:</b>	Forest
<b>East:</b>	Forest Residential	<b>West:</b>	Forest

### Staff Information

**Report Presenter:** Ronda Kippen  
rkippen@co.weber.ut.us  
801-399-8768

**Report Reviewer:** JG

## Applicable Ordinances

- Title 101, Chapter 1, General Provisions, Section 7, Definitions
- Title 104, Chapter 9 Forest Zones (F-5)
- Title 104, Chapter 28, Ogden Valley Sensitive Lands Overlay Districts
- Title 104, Chapter 1 Design Review
- Title 108, Chapter 4 Conditional Uses
- Title 108, Chapter 10 Public Buildings and Public Utility Substations and Structures

## Summary and Background

The applicant is requesting approval for a conditional use permit for a culinary well and associated pump house to be located at approximately 6649 N. North Fork Road, Liberty, UT. The property lies in the Forest 5 Zone (F-5) which allows "Water pumping plants and reservoirs" as well as "Public utility substations and transmission lines" only when authorized by a conditional use permit. Liberty Pipeline Company has identified the need to increase their culinary water system and has conducted a hydro-geologic study to identify a location for a new well (see Exhibit A). The proposed location has been deemed the most favorable for the well considering the layout and needs of Liberty Pipeline Company for the expansion of the culinary water system. The proposed site is located along the northern property line of "Camp Lomondi" in the North Park area on property owned by the Mount Ogden Stake of the Church of Jesus Christ of Latter Day Saints.

The property is used as a private campground during the summer months with multiple outbuildings on site that are considered accessory structures to the private campground. Liberty Pipeline Company will need to secure the applicable easements from the property owners to utilize approximately 23,682 sq. ft. (0.5436 acres) including an access easement, a perpetual easement, source protection easement, and construction easement in order to create and maintain legal access

to the site. The proposal is not anticipated to negatively impact the adjacent property owners due to the remoteness of the site and the small scale of the project. The proposed use will be beneficial to the residents of the Liberty area by providing adequate culinary water services to the property owners within the Liberty Pipeline Company servicing district.

Conditional use permits should be approved as long as any harmful impact is mitigated. The Uniform Land Use Code of Weber County, Utah (LUC) already specifies certain standards necessary for mitigation of harmful impact to which the proposal must adhere. The proposed application appears to meet these standards. The following is staff's evaluation of the request.

## Analysis

**General Plan:** The Ogden Valley General Plan identifies the need for new water sources to meet the demands of future growth while balancing the concern regarding the number of private wells and the cumulative impacts on water availability and water quality. The proposal supports the long-term goal to improve and expand the Valley's existing water systems throughout developing areas. (see the 1998 Ogden Valley General Plan §9.03 Water System & 9.04 Private Wells).

**Zoning:** The subject property is located within the F-5 Zone which is categorized as a "Forest Zone". The intent of the forest zones can be further described per LUC §104-9-1 as follows:

- a. *The intent of the forest zones is to protect and preserve the natural environment of those areas of the county that are characterized by mountainous, forest or naturalistic land, and to permit development compatible to the preservation of these areas.*
- b. *The objectives in establishing the forest zones are:*
  1. *To promote the use of the land for forest, fish and wildlife and to facilitate the conservation of the natural resources, vegetation and attractions;*
  2. *To reduce the hazards of flood and fire;*
  3. *To prevent sanitation and pollution problems and protect the watershed;*
  4. *To provide areas for private and public recreation and recreation resorts; and*
  5. *To provide areas for homes, summer homes, and summer camp sites.*

The F-5 Zone has specific standards identified in the LUC §104-9-4 that shall be met as part of the development process. The applicable standards are as follows:

- Minimum yard setbacks:
  - Front: 30'
  - Side: 20'
  - Rear: 30'
- Minimum lot area: 5 acres
- Minimum lot width: 300'
- Main Building height:
  - Maximum: 35'
  - Accessory building height:
    - Maximum: 25', unless meeting requirements of LUC §108-7-16, Large accessory buildings

The proposed use is conditionally allowed in the F-5 zone and has been reviewed as a "Water pumping plants and reservoirs" as well as "Public utility substations and transmission lines". The location and arrangement of public utility substations and structures must be in accordance with construction plans submitted to and approved by the planning commission. The minimum lot area for all public utility substations per LUC §108-10-2 is waived and the rear yard requirements may be reduced in the Forest Zones to 20' per LUC §108-10-3.

The Ogden Valley Sensitive Lands Overlay Districts Zone has specific standards identified in the LUC §104-28-2 that shall be met as part of the development process. The applicable standards are as follows:

### *Development standards.*

*(1) Setbacks. No structure, accessory structure, road, or parking area shall be built within the required setback from a river or stream as measured from the high water mark of the river or stream. The high water mark shall be determined by the Weber County engineer. The areas within the setback shall be maintained in a manner that protects the quality of water in the river or stream and the habitat of native vegetation and wildlife along the river or stream.*



*a. Structures, accessory structures, roads, or parking areas shall not be developed or located within 100 feet on both sides of the North Fork, South Fork, and Middle Fork of the Ogden River, from the high water mark of the river.*

*b. Structures, accessory structures, roads, or parking areas shall not be developed or located within 75 feet on both sides of year-round streams, as determined from the high water mark of the stream.*

*c. Structures, accessory structures, roads, or parking areas shall not be developed or located within 50 feet from the high water mark of a natural ephemeral stream.*

According to the proposal, it appears that a portion of the improvements will fall within the required 100' setback for the North Fork River running along the east side of the identified easement area. The proposed improvements in this area will be underground and the applicant has provided adequate reclamation plans to ensure that the stream corridor is maintained in a manner that protects the intent of this code. A condition has been made part of the Planning Division's recommendations to ensure that this standard is met. With the recommended conditions of approval, the proposal appears to meet all of the standards identified.

**Conditional Use Review:** A review process has been outlined in LUC §108-4-3 to ensure compliance with the applicable ordinances and to mitigate anticipated detrimental effects. The property is currently owned by the Mount Ogden Stake of the Church of Jesus Christ of Latter Day Saints. The well protection area will encroach on the neighboring property to the north which is owned by the Lewis Swain Family Trust. A draft of the necessary easements has been provided to the Planning Division; however, a final signed copy of all easements and/or lease agreement for the access, location and affiliated construction for the proposed culinary well and pump house will need to be provided to the Planning Division prior to the issuance of the conditional use permit.

The applicant has provided proof of water and a copy of the "Project Notification Form" that has been submitted to the State of Utah Division of Drinking Water for approval. Prior to commencing work, Liberty Pipeline Company will need to receive approval from the applicable agencies for the new culinary well and pump house. A condition has been made part of the Planning Division's recommendations to ensure that this standard is met.

**Design Review:** The forest zone and the proposed conditional use, mandate a design review as outlined in LUC §108-1 to ensure that the general design, layout and appearance of the building remains orderly and harmonious with the surrounding neighborhood. Certain areas of the design review are only applicable due to the nature of the request. As part of this review, the Planning Commission shall consider the applicable matters based on the proposed conditional use and impose conditions to mitigate deficiencies where the plan is found deficient. The matters for consideration are as follows:

- *Considerations relating to traffic safety and traffic congestion.* As part of this consideration, the applicant has provided detailed a site plan (see Exhibit B). The proposal is not considered large scale construction; therefore considerable traffic congestion or delay is not anticipated. Per the County Engineering Division, the contractor will be responsible to guarantee site materials are not tracked onto the County roadways. A condition of approval has been added to the Planning Division's recommendation to ensure the contractor cleans all equipment prior to exiting the site and sweeps the County roadway as needed, removing any material tracked from the site onto the asphalt, in order to provide safe vehicular traffic along North Fork Road. A condition has been made part of the Planning Division's recommendations to ensure that this standard is met.
- *Considerations relating to landscaping.* The area of disturbance is very minimal. The proposal has been designed in a manor to maintain all mature trees in the area. It is anticipated that some trimming of the mature trees will be necessary and all trees that are removed during construction will be replanted with the same species conifer tree. The disturbed area will be reseeded after construction with native grasses (see Exhibit C).
- *Considerations relating to buildings and site layout.* The proposed pump house is 12' x 16' (see Exhibit C). The external surface of the structure is proposed to be constructed of grey concrete masonry units with a forest green non-reflective metal roof. The Ogden Valley Architectural, Landscaping and Screening Design Standards as outlined in LUC §108-2-4(2) does not allow for "CMUs" for "exposed fronts and street sides of buildings" unless it is specially colored and textured. The applicant has proposed the grey CMU design in order to remain consistent with the existing structures onsite. Due to the structure not being visible from the public street, it appears that the proposal meets the minimum requirements of the applicable areas of the Uniform Land Use Code of Weber County.

- *Considerations relating to utility easements, drainage, and other engineering questions.* The applicant will need to adhere to all conditions of the Engineering Division including but not limited to storm water and surface water drainage, retention facilities, and site clean-up of the property. A condition has been made part of the Planning Division’s recommendations to ensure that this standard is met.
- *Considerations relating to prior development concept plan approval associated with any rezoning agreement, planned commercial or manufacturing rezoning, or planned residential unit development approval.* The proposed site does not have any type of development agreement associated with the property; therefore considerations pertaining to this portion of the code are not applicable at this time.

**Review Agencies:** Prior to the commencement of work, the applicant will need to receive the approval from all applicable agencies for the water system improvements. A condition has been made part of the Planning Division’s recommendations to ensure that all conditions of the review agencies will be met.

### Conformance to the General Plan

The proposed use conforms to the Ogden Valley General Plan by providing additional water sources to meet the demands of the Valley’s existing water systems throughout developing areas.

### Summary of Planning Commission Considerations

In order for a conditional use to be approved it must meet the requirements of applicable ordinances listed in this staff report, which include the requirements listed in LUC §108-4-4, under “Criteria for Issuance of Conditional Use Permit”, which states:

*Conditional Uses shall be approved on a case-by case basis. The planning commission shall not authorize a conditional use permit unless evidence is present to establish:*

1. *Reasonably anticipated detrimental effects of a proposed conditional use can be substantially mitigated by the proposal or by the imposition of reasonable conditions to achieve compliance with applicable standards. Examples of potential negative impacts are odor, vibration, light, dust, smoke or noise.*
2. *That the proposed use will comply with the regulations and conditions specified in the Land Use Code and other applicable agency standards of use.*

The Planning Commission will need to determine if the request for a culinary well and associated pump house has met the requirements of the applicable Uniform Land Use Code of Weber County. The Planning Commission may impose additional conditions in order to ensure full compliance with the required standards. In making a decision, the Planning Commission should consider the following questions:

- Does the submittal meet the Uniform Land Use Code of Weber County? If no, then what conditions could be added in order to comply?
- Have the “Criteria for Issuance of Conditional Use Permit” and other applicable ordinances been met?

### Staff Recommendation

The Planning Division recommends approval of file# CUP 2015-08, a conditional use permit for the LPC Lomondi Well, a culinary well and associated pump house, to be located at approximately 6649 N. North Fork Road, Liberty, UT. This recommendation for approval is subject to all review agency requirements and with the following conditions:

1. Prior to the issuance of the conditional use permit, a final signed copy of all easements and/or lease agreement for the access, location and affiliated construction for the proposed culinary well and pump house will need to be provided to the Planning Division.
2. The site will be restored per the attached site plan to ensure the stream corridor is maintained in a manner that protects the intent of this code.
3. Prior to commencing work, Liberty Pipeline Company will need to receive the approval from the applicable agencies for the new culinary well and pump house.
4. All equipment leaving the site will be cleaned prior to entering the County right-of-way and the contractor will be responsible for sweeping the County roadway, as needed, removing any material tracked from the site onto the asphalt, in order to provide safe vehicular traffic along North Fork Road.
5. Requirements of the Weber County Building Inspection Division.



6. Requirements and recommendations of the Weber Fire District.
7. Requirements of the Weber County Engineering Division.
8. Requirements of the Weber County Health Department.

This recommendation is based on the following findings:

1. The proposed use conforms to the Ogden Valley General Plan.
2. The proposed use will provide the needed water sources to meet the demands the Ogden Valley.
3. The proposed use, if conditions are imposed, will not be detrimental to the public health, safety, or welfare.
4. The proposed use, if conditions are imposed, will comply with applicable County ordinances.
5. The proposed use will not deteriorate the environment of the general area so as to negatively impact surrounding properties and uses.

## Exhibits

- A. Application
- B. Site Plan
- C. Building & Landscape Plan

Map 1

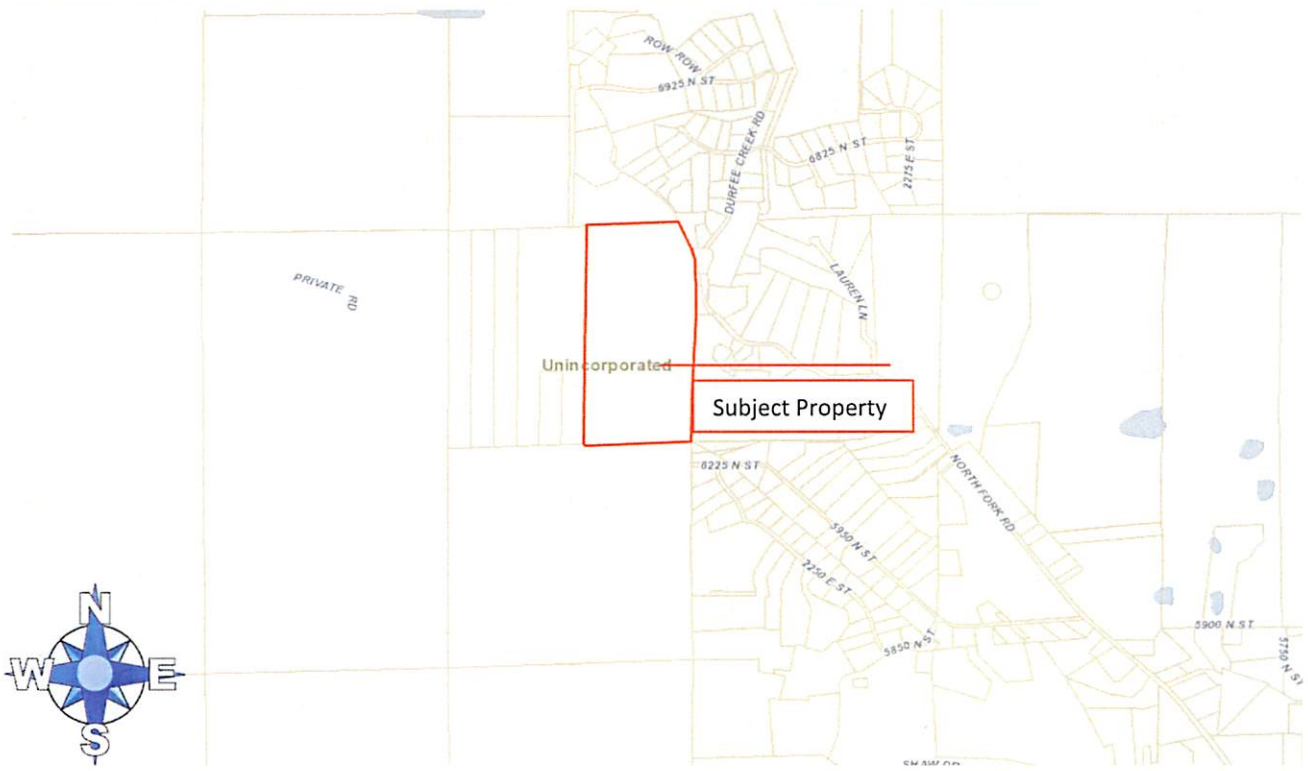

Map 2

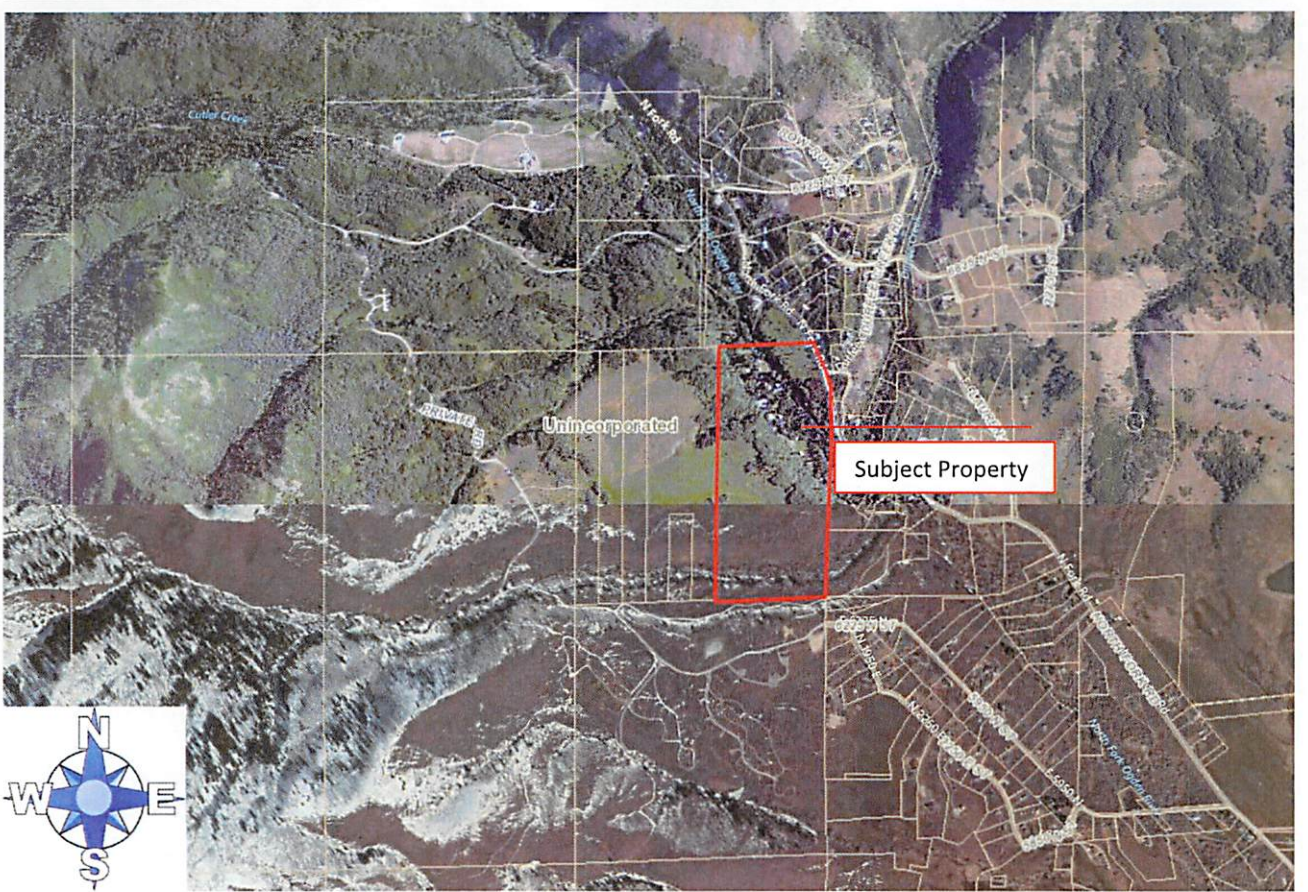



## Exhibit A-Application

<b>Weber County Conditional Use Permit Application</b>			
Application submittals will be accepted by appointment only. (801) 399-8791. 2380 Washington Blvd. Suite 240, Ogden, UT 84401			
Date Submitted / Completed 2-24-2015	Fees (Office Use)	Receipt Number (Office Use)	File Number (Office Use)
<b>Property Owner Contact Information</b>			
Name of Property Owner(s) MOUNT OGDEN STAKE OF THE CHURCH OF JESUS CHRIST OF LDS Lewis Swain		Mailing Address of Property Owner(s) 50 EAST NORTH TEMPLE, 12 FLOOR SALT LAKE CITY, UTAH 84150-0012	
Phone 801-240-1010	Fax	1688 Canyon Cir Farmington, UT 84025	
Email Address MARCHESCHI@LDSCHURCH.ORG		Preferred Method of Written Correspondence <input checked="" type="checkbox"/> Email <input type="checkbox"/> Fax <input type="checkbox"/> Mail	
hlswain@gmail.com			
<b>Authorized Representative Contact Information</b>			
Name of Person Authorized to Represent the Property Owner(s) MIKE DURTSCHI		Mailing Address of Authorized Person 5150 S 475 E OGDEN, UT 84405	
Phone 801-476-0202	Fax		
Email Address MIKED@GARDNERENGINEERING.NET		Preferred Method of Written Correspondence <input checked="" type="checkbox"/> Email <input type="checkbox"/> Fax <input type="checkbox"/> Mail	
<b>Property Information</b>			
Project Name LPC LOMONDI WELL		Total Acreage 69.24	Current Zoning F-5
Approximate Address 6649 N NORTH FORK ROAD LIBERTY, UTAH		Land Serial Number(s) 160-01-0005	
Proposed Use WELL - CULINARY WATER - 104-9-3(14)			
Project Narrative Liberty Pipeline Company in agreement with the owner of the property, is proposing to install a well with a 12' x 16' pump house. This project will increase capacity of culinary water system.			

## Exhibit A-Application

### **Basis for Issuance of Conditional Use Permit**

That the proposed use of the particular location is necessary or desirable to provide a service or facility which will contribute to the general well being of the community:

Hydro-geologic study was conducted to site the proposed well. This location is currently the most favorable location for a well considering the layout and needs of Liberty Pipeline Company.

That such use will not, under the circumstances of the particular case and the conditions imposed, be detrimental to the health, safety and general welfare of persons nor injurious to property or improvements in the community, but will be compatible with and complimentary to the existing surrounding uses, buildings and structures when considering traffic generation, parking, building design and location, landscaping and signs:

Construction of the project will take place when camp occupants are not present. Use of the facility will only generate infrequent and minimal maintenance traffic. As such no appreciable safety issues are foreseen.

## Exhibit A-Application

That the proposed use will comply with the regulations and conditions specified in this Ordinance for such use:  
Land Use Ordinance Section 104-9-3(14).

That the proposed use conforms to the goals, policies and governing principles and land use of the General Plan for Weber County:



## Exhibit A-Application

That the proposed use will not lead to the deterioration of the environment or ecology of the general area, nor will produce conditions or emit pollutants of such a type or of such a quantity so as to detrimentally effect, to any appreciable degree, public and private properties including the operation of existing uses thereon, in the immediate vicinity of the community or area as a whole:

SWPP Plan and BMP's will be implemented on site during construction. It is anticipated that no appreciable environmental impact will come from the constructed project.

### Property Owner Affidavit

I (We), H Lewis Swain depose and say that I (we) am (are) the owner(s) of the property identified in this application and that the statements herein contained, the information provided in the attached plans and other exhibits are in all respects true and correct to the best of my (our) knowledge.

H Lewis Swain  
(Property Owner)

\_\_\_\_\_  
(Property Owner)

Subscribed and sworn to me this 31 day of August, 2015

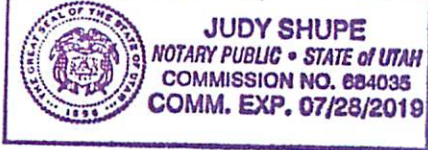

Judy Shupe  
(Notary)

### Authorized Representative Affidavit

I (We), H Lewis Swain, the owner(s) of the real property described in the attached application, do authorized as my (our) representative(s), Gardner Engineering - Mike Durtschi, to represent me (us) regarding the attached application and to appear on my (our) behalf before any administrative or legislative body in the County considering this application and to act in all respects as our agent in matters pertaining to the attached application.

H Lewis Swain  
(Property Owner)

\_\_\_\_\_  
(Property Owner)

Dated this 31 day of August, 2015, personally appeared before me H Lewis Swain, the signer(s) of the Representative Authorization Affidavit who duly acknowledged to me that they executed the same.

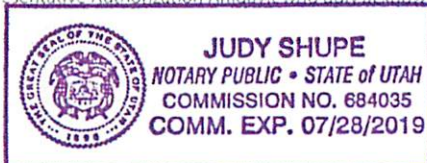

Judy Shupe  
(Notary)

# Exhibit A-Application

That the proposed use will not lead to the deterioration of the environment or ecology of the general area, nor will produce conditions or emit pollutants of such a type or of such a quantity so as to detrimentally effect, to any appreciable degree, public and private properties including the operation of existing uses thereon, in the immediate vicinity of the community or area as a whole:

SWPP Plan and BMP's will be implemented on site during construction. It is anticipated that no appreciable environmental impact will come from the constructed project.

## Property Owner Affidavit

I (We), South Weber Stake of the Church of Jesus Christ of Latter-day Saints, depose and say that I (we) am (are) the owner(s) of the property identified in this application and that the statements herein contained, the information provided in the attached plans and other exhibits are in all respects true and correct to the best of my (our) knowledge.

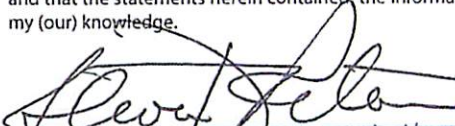
  
SIGN HERE  
(Property Owner) Steven K. Peterson, in his capacity as President of the South Weber Stake of the Church of Jesus Christ of Latter-day Saints, and as the Incumbent Corporate Officer of the South Weber Stake of the Church of Jesus Christ of Latter-day Saints, successor by merger to the Mount Ogden Stake of the Church of Jesus Christ of Latter-day Saints  
Subscribed and sworn to me this 3RD day of September, 2015

(Property Owner) \_\_\_\_\_

 **GORDON R. JESSEE**  
NOTARY PUBLIC - STATE OF UTAH  
My Comm. Exp. 08/17/2016  
Commission # 657118

  
\_\_\_\_\_  
(Notary)

## Authorized Representative Affidavit

I (We), South Weber Stake of the Church of Jesus Christ of Latter-day Saints, the owner(s) of the real property described in the attached application, do authorized as my (our) representative(s), Gardner Engineering - Mike Durtschi, to represent me (us) regarding the attached application and to appear on my (our) behalf before any administrative or legislative body in the County considering this application and to act in all respects as our agent in matters pertaining to the attached application.

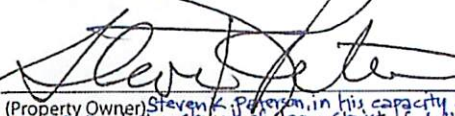
  
SIGN HERE  
(Property Owner) Steven K. Peterson, in his capacity as President of the South Weber Stake of the Church of Jesus Christ of Latter-day Saints, and as the Incumbent Corporate Officer of South Weber Stake of the Church of Jesus Christ of Latter-day Saints, successor by merger to the Mount Ogden Stake of the Church of Jesus Christ of Latter-day Saints

(Property Owner) \_\_\_\_\_

Dated this 3RD day of September, 2015, personally appeared before me Steven K. Peterson the signer(s) of the Representative Authorization Affidavit who duly acknowledged to me that they executed the same, in his capacity referenced above.

 **GORDON R. JESSEE**  
NOTARY PUBLIC - STATE OF UTAH  
My Comm. Exp. 08/17/2016  
Commission # 657118

  
\_\_\_\_\_  
(Notary)



# Exhibit B-Site Plan

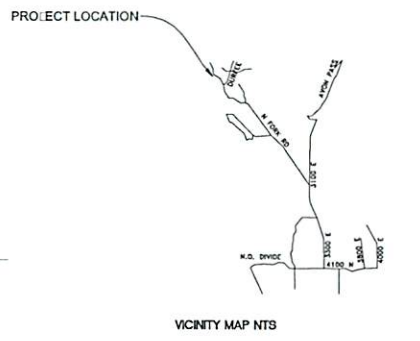
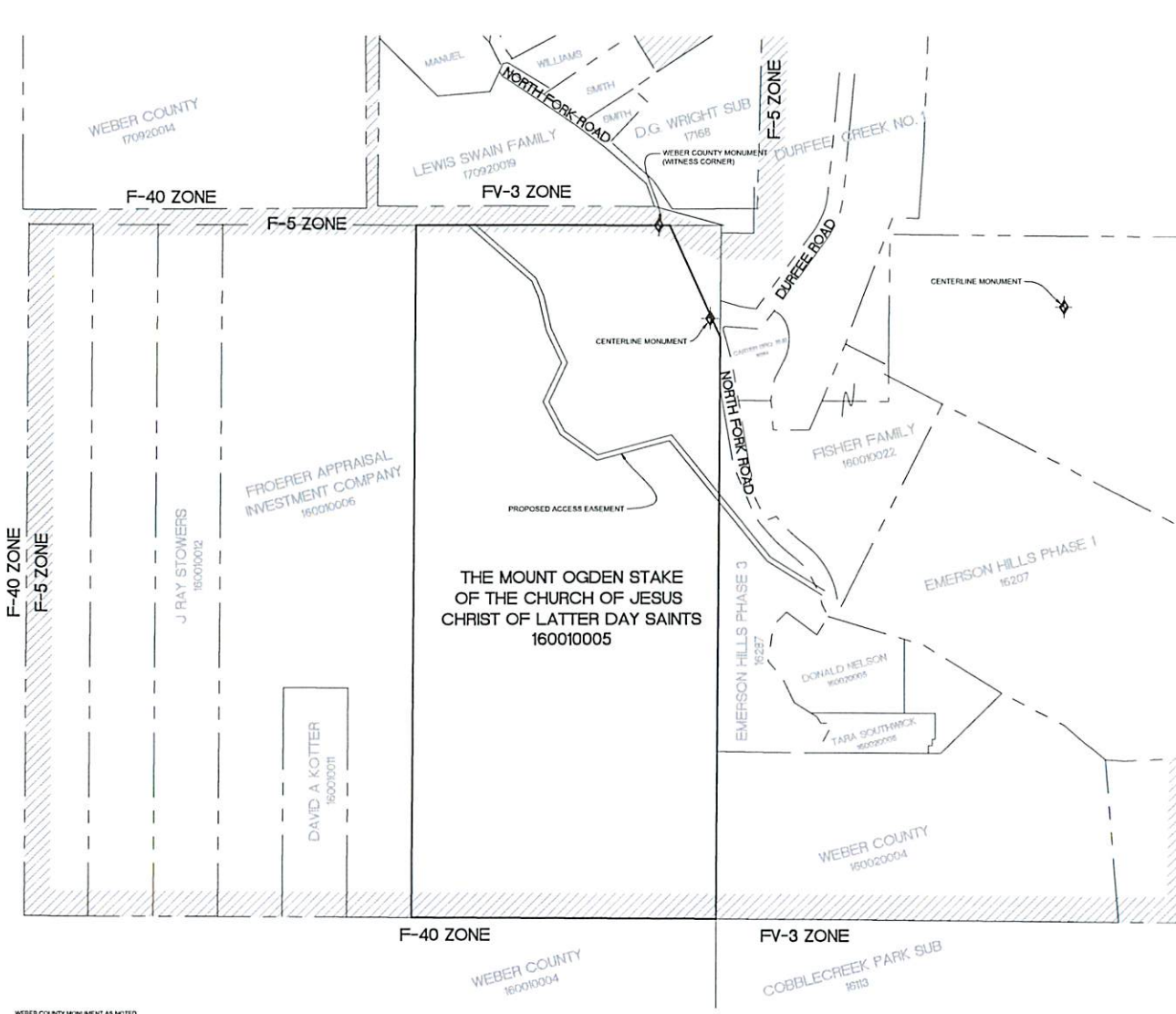

**NARRATIVE**

THE PURPOSE OF THIS EXHIBIT DRAWING IS TO SHOW CURRENT OWNERSHIP AND ZONING OF THE PROPERTIES SURROUNDING THE LIBERTY PIPELINE WELL SITE.

- WEBER COUNTY MONUMENT AS NOTED
- SET 24" REBAR AND CAP MARKED GARDNER ENGINEERING
- SUBJECT PROPERTY LINE
- ADJACENT PARCEL
- SECTION LINE
- PROPOSED EASEMENT
- EXISTING FENCE

**SURVEYOR'S CERTIFICATE**

I, KLINT H. WHITNEY, DO HEREBY CERTIFY THAT I AM A LICENSED PROFESSIONAL LAND SURVEYOR IN THE STATE OF UTAH AND THAT I HOLD CERTIFICATE NO. 8227228 IN ACCORDANCE WITH TITLE 5A, CHAPTER 22, OF THE PROFESSIONAL ENGINEERS AND LAND SURVEYORS ACT. I FURTHER CERTIFY THAT BY AUTHORITY OF THE OWNERS I HAVE COMPLETED A SURVEY OF THE PROPERTY DESCRIBED ON THIS RECORD OF SURVEY PLAN IN ACCORDANCE WITH SECTION 17-2-1.1 AND HAVE VERIFIED ALL MEASUREMENTS. THAT THE REFERENCE MONUMENTS SHOWN ON THIS RECORD OF SURVEY PLAN ARE LOCATED AS INDICATED AND ARE SUFFICIENT TO REDEFINE OR REESTABLISH THIS SURVEY; AND THAT THE INFORMATION SHOWN HEREIN IS SUFFICIENT TO ACCURATELY ESTABLISH THE LATERAL BOUNDARIES OF THE HEREIN DESCRIBED TRACT OF REAL PROPERTY.

SIGNED THIS \_\_\_\_\_ DAY OF \_\_\_\_\_, 2014.



REVISIONS	DATE	DESCRIPTION
1	2/18/13	

DATE: 2/18/13  
DRAWN BY: [Blank]  
CHECKED BY: [Blank]  
DATE: [Blank]

PROPERTY OWNERSHIP EXHIBIT FOR LPC  
LOMONDI WELL, LIBERTY, WEBER COUNTY, UTAH  
LOCATED IN THE NORTHWEST QUARTER OF SECTION 1,  
TOWNSHIP 7 NORTH, RANGE 1 WEST, S.L.B. AND M.

**GARDNER ENGINEERING**  
CIVIL • LAND PLANNING  
MUNICIPAL • LAND SURVEYING

S1  
1



**SITE PLAN**  
**LPC LOMONDI WELL**  
 6649 N NORTH FORK RD.

PART OF SECTION 01,  
 TOWNSHIP 7N, RANGE 1W,  
 SALT LAKE BASE AND MERIDIAN  
 LIBERTY, WEBER, UTAH

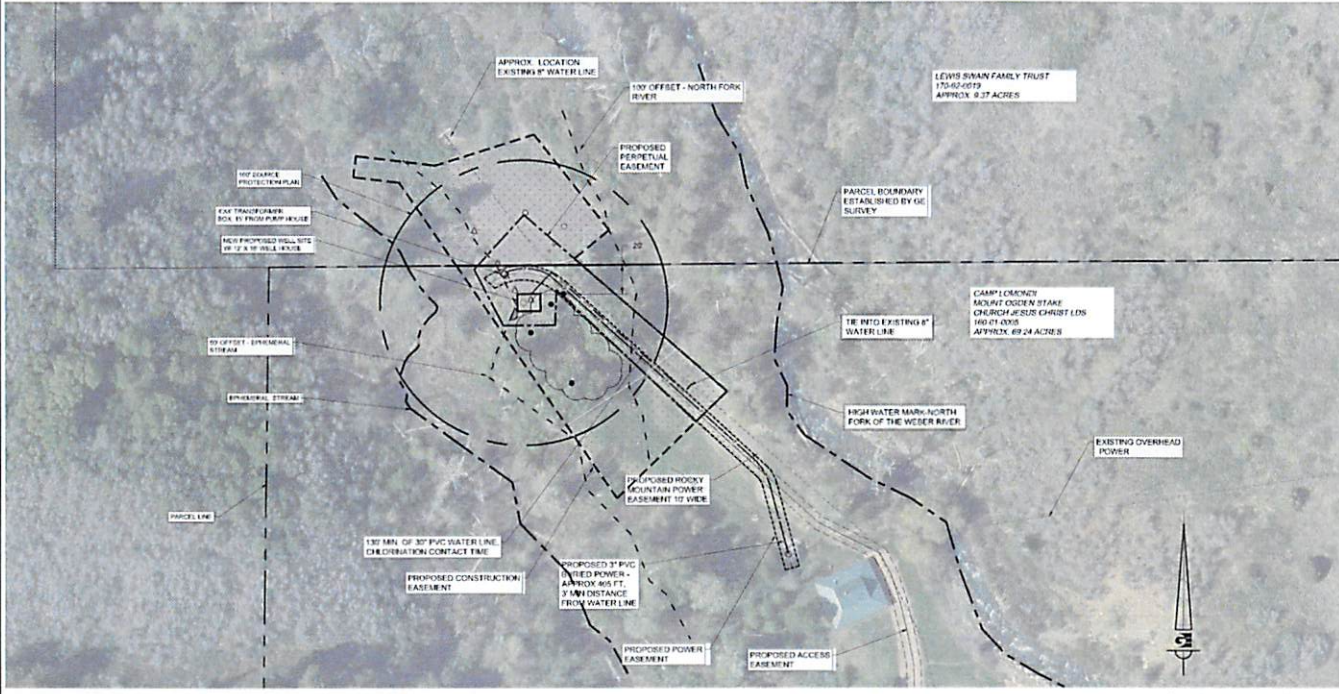

PROJ. ECT. SITE PLAN RE. UREMENT	S. FT.	PERCENTAGE
PROJ. ECT. SITE AREA	23682	100
BUILDING COVERAGE	102	1
GRAVEL COVERAGE	0	0
LANDSCAPING	23430	99
EXISTING CONING	F-5	
CONVENTIONAL USE	104-9-3(14) CULINARY WELL	

TOTAL AREA DISTURBED 23682  
 CONTRACTOR WILL BE RESPONSIBLE FOR THE CONDITIONS OF THE SITE DURING CONSTRUCTION.  
 NEIGHBORS WILL NOT BE AFFECTED BECAUSE OF THE DISTANCE BETWEEN THE HOME AND PROPERTY LINE.  
 CONCRETE WASHOUT SHOWN ON PLAN WILL BE MAINTAINED DURING CONSTRUCTION AND REMOVED AFTER CONSTRUCTION BY CONTRACTOR.  
 PORTA DCHN SHOWN ON PLAN WILL BE PROVIDED AND MAINTAINED BY A PORTA DCHN COMPANY SELECTED AND RETAINED BY CONTRACTOR.  
 NO CONSTRUCTION ENTRANCE IMPROVEMENTS ARE NEEDED, AS EXISTING ACCESS IS GRAVEL.  
 MUD OR DIRT IS UNLIKELY TO REACH THE ASPHALT ROAD LOCATED 1/2 MILE AWAY. CONTRACTOR IS RESPONSIBLE TO SWEEP ASPHALT AS NEEDED.  
 NORTH FORK OF THE WEBER RIVER IS THE CLOSEST DRAINAGE, APPROX. 250 FT FROM CONSTRUCTION ACTIVITIES. IT WILL BE PROTECTED BY A SILT FENCE.  
 STORM WATER CURRENTLY RUNS TO THE SOUTH SOUTH EAST TO EPHEMERAL STREAM.  
 NO EXISTING OCCUPATION DURING CONSTRUCTION. SITE IS A SEASONAL GIRLS CAMP/GROUND.

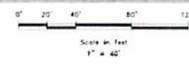

**Exhibit B-Site Plan**

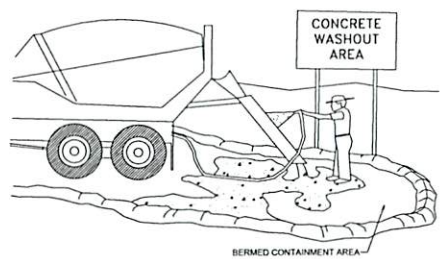
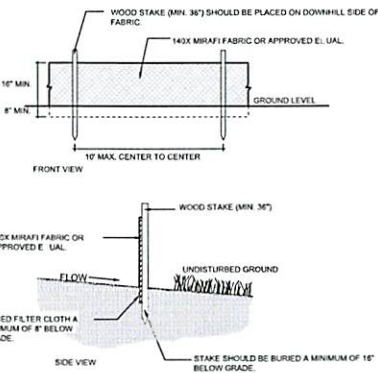

- NOTES:**
1. EXCESS AND WASTE CONCRETE SHALL NOT BE WASHED INTO THE STREET OR INTO A DRAINAGE SYSTEM.
  2. FOR WASHOUT OF CONCRETE AND MORTAR PRODUCTS, A DESIGNATED CONTAINMENT FACILITY OF SUFFICIENT CAPACITY TO RETAIN LIQUID AND SOLID WASTE SHALL BE PROVIDED ON SITE.
  3. SLURRY FROM CONCRETE AND ASPHALT SAW CUTTING SHALL BE VACUUMED OR CONTAINED, DRIED, PICKED UP AND DISPOSED OF PROPERLY.

**WELL OWNER**  
 SHERRY PERLINE COMPANY  
 1000 W. 1000 S. SALT LAKE CITY, UT 84119  
 801-224-2626

**PROPERTY OWNER**  
 THE CHURCH OF JESUS CHRIST OF LATTER-DAY SAINTS - ST. MARK OF THE BISHOP GROUP  
 CONTACT: MICHAEL MARSHALL  
 86 EAST WASH. TRUCK STREET, 1ST FL. PLUM  
 SALT LAKE CITY, UT 84143-0019  
 801-224-2626

**SITE PLAN**  
 LPC LOMONDI WELL  
 6649 N NORTH FORK RD.  
 LIBERTY, WEBER, UTAH

**GARDNER ENGINEERING**  
 CIVIL, LAND PLANNING  
 MUNICIPAL, LAND SURVEYING  
 1000 W. 1000 S. SALT LAKE CITY, UT 84119  
 801-224-2626

C1  
 2



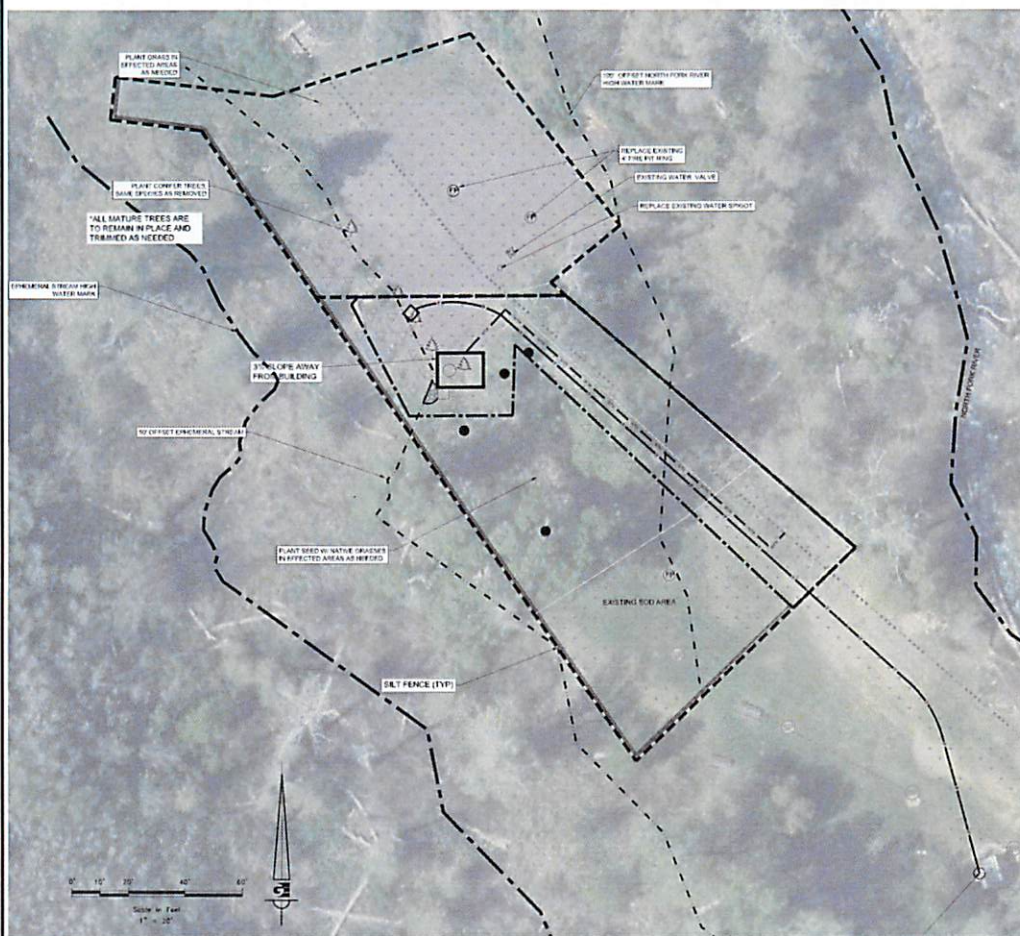

PLANT SPECIES	COMPOSITION NAME	% BY HEIGHT
PLANT SPECIES	Solar Shrubbery	25%
PLANT SPECIES	Manzanita	4%
PLANT SPECIES	Yucca	15%
PLANT SPECIES	Joshua Tree	4%
PLANT SPECIES	Shrub	4%
PLANT SPECIES	Manzanita	25%
PLANT SPECIES	Joshua Tree	25%
PLANT SPECIES	White Gully Clover	3%
<b>TOTAL LBS/ACRE</b>		<b>20.5 (1,851,000 SF)</b>

**NOTE:**  
ALL AREAS DISTURBED BY CONSTRUCTION OF WELL WILL BE RETURNED TO THE NATURAL CONDITIONS. MATERIALS USED FOR CONSTRUCTION WILL BE EXCAVATED AND REMOVED. SPILLING MUDS AND EARTH MATERIALS SHALL BE CONTAINED AND DISPOSED OF AT AN APPROVE FACILITY. DRILLING FLUIDS, DRILL CUTTINGS AND PRODUCED WATER SHALL BE CONTAINED IN ABOVE-GROUND TANKS AND DISPOSED OF IN A MANNER TO PREVENT SURFACE OR SUBSURFACE CONTAMINATION AND TO PREVENT DEGRADATION OF NATURAL OR MAN-MADE WATER COURSES, IMPROVEMENTS, WATERWAYS, LAKES, RESERVOIRS, IRRIGATION DITCHES, STORM SEWERS, AND DRY STREAM BEDS.

# LANDSCAPING PLAN

## LPC LOMONDI WELL

6649 N NORTH FORK RD.

PART OF SECTION 01,  
TOWNSHIP 7N, RANGE 1W,  
SALT LAKE BASE AND MERIDIAN  
LIBERTY, WEBER, UTAH

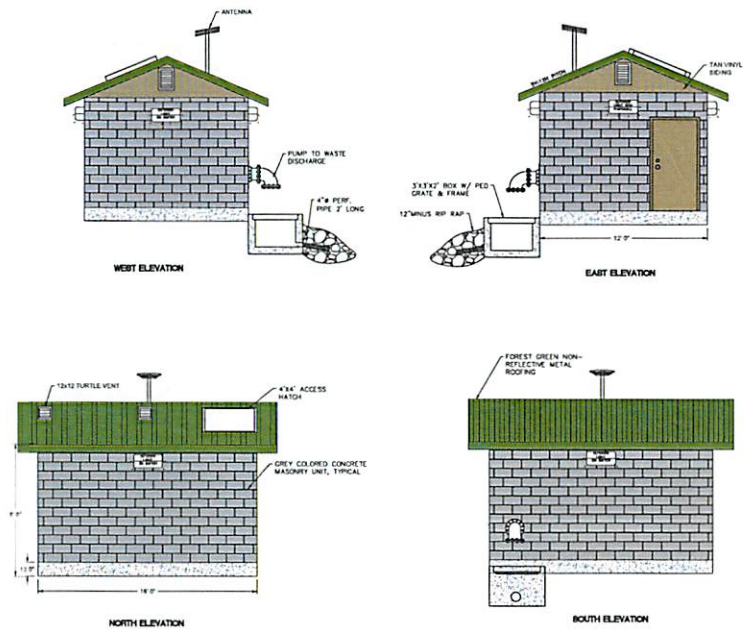

**12' X 16' PUMP HOUSE**

**NOTES:**  
VENTILING PER CODE  
ATTIC ROOF - 5-12 PITCH  
4' X 4' ROOF ACCESS HATCH FOR PUMP MAINTENANCE  
METAL ROOF - FOREST GREEN  
CMU STRUCTURE - GREY  
COLORS TO MATCH EXISTING BUILDINGS ON SITE  
SPREAD FOOTING BEARING 40\"/>

**WELL OWNER:**  
LIBERTY PETROLEUM COMPANY  
CONTACT: JIM HALL  
201 N. MAIN  
SALT LAKE, UT 84119  
801-734-7811

**PROPERTY OWNER:**  
THE COUNTY OF ZION COUNTY OF UTAH-OUT  
COUNTY - ZION COUNTY  
CONTACT: MICHAEL WARRINGTON  
26 EAST SPRING TRAIL STREET, 13 TH FLOOR  
SALT LAKE CITY, UT 84103-0119  
801-468-0044

<p>REVISIONS</p> <table border="1"> <tr> <th>NO.</th> <th>DATE</th> <th>DESCRIPTION</th> </tr> <tr> <td>1</td> <td>11-15-14</td> <td>PRELIMINARY</td> </tr> </table>	NO.	DATE	DESCRIPTION	1	11-15-14	PRELIMINARY	<p><b>Page 14 of 14</b></p>
NO.	DATE	DESCRIPTION					
1	11-15-14	PRELIMINARY					
<p>LANDSCAPING PLAN</p> <p>LPC LOMONDI WELL</p> <p>6649 N NORTH FORK RD.</p> <p>LIBERTY, WEBER, UTAH</p>							
<p><b>GARDNER ENGINEERING</b></p> <p>CIVIL/LAND PLANNING MUNICIPAL/LAND SURVEYING</p> <p>OFFICE: 3001 47th Avenue, Suite 200, Ogden, UT 84403</p>							
<p>C2</p>	<p>2</p>						