

9 OPEN DRIVEWAY APPROACH
SCALE: N.T.S.

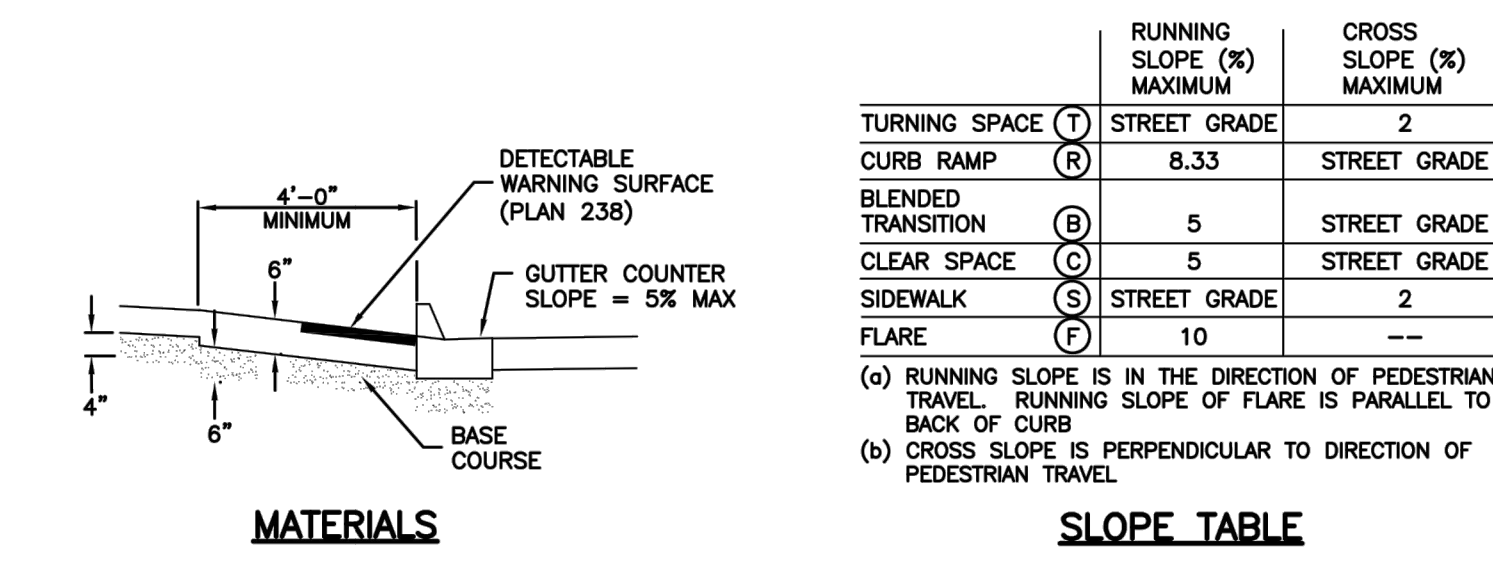

8 MIDBLOCK CURB CUT ASSEMBLY (1)
SCALE: N.T.S.

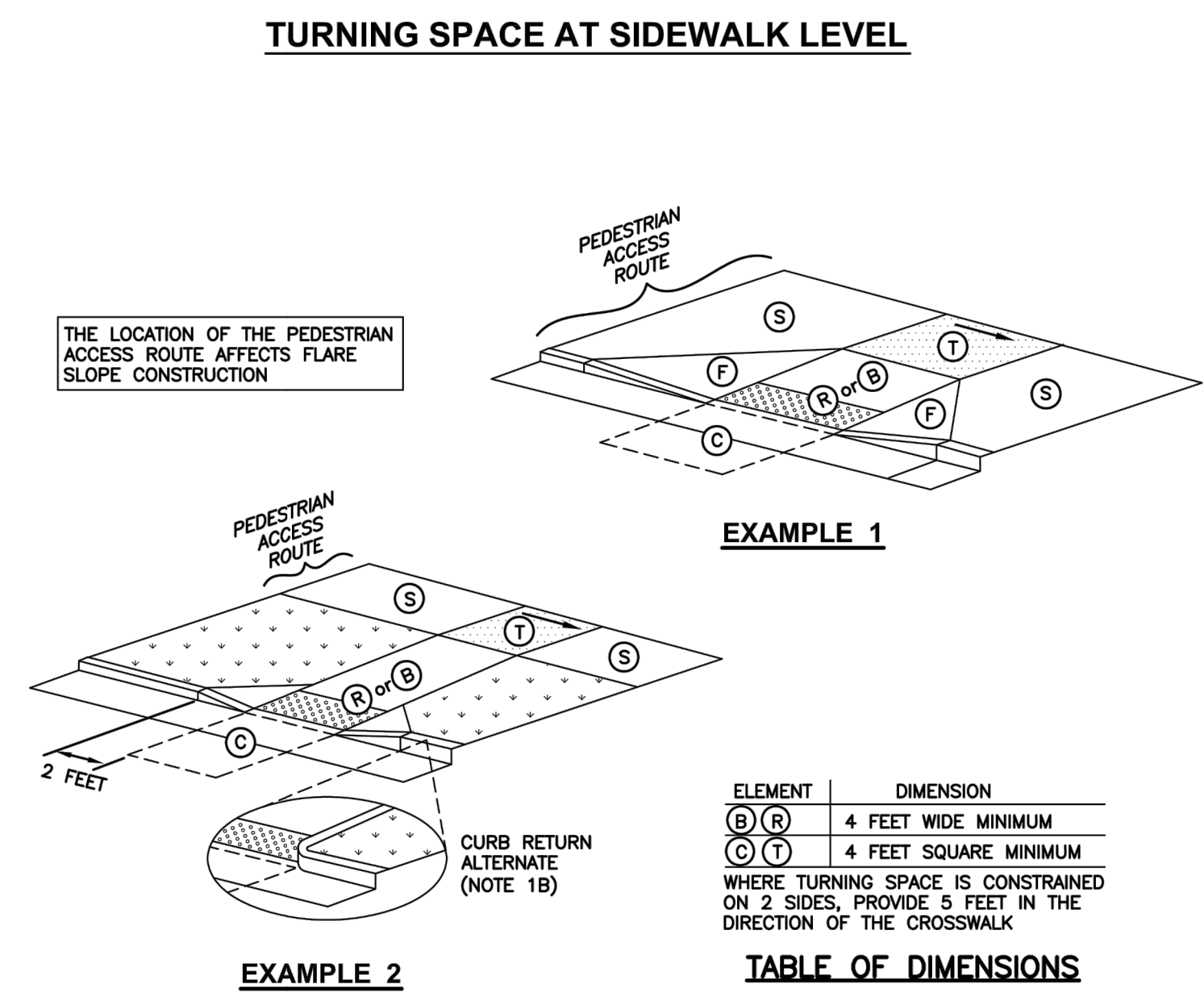
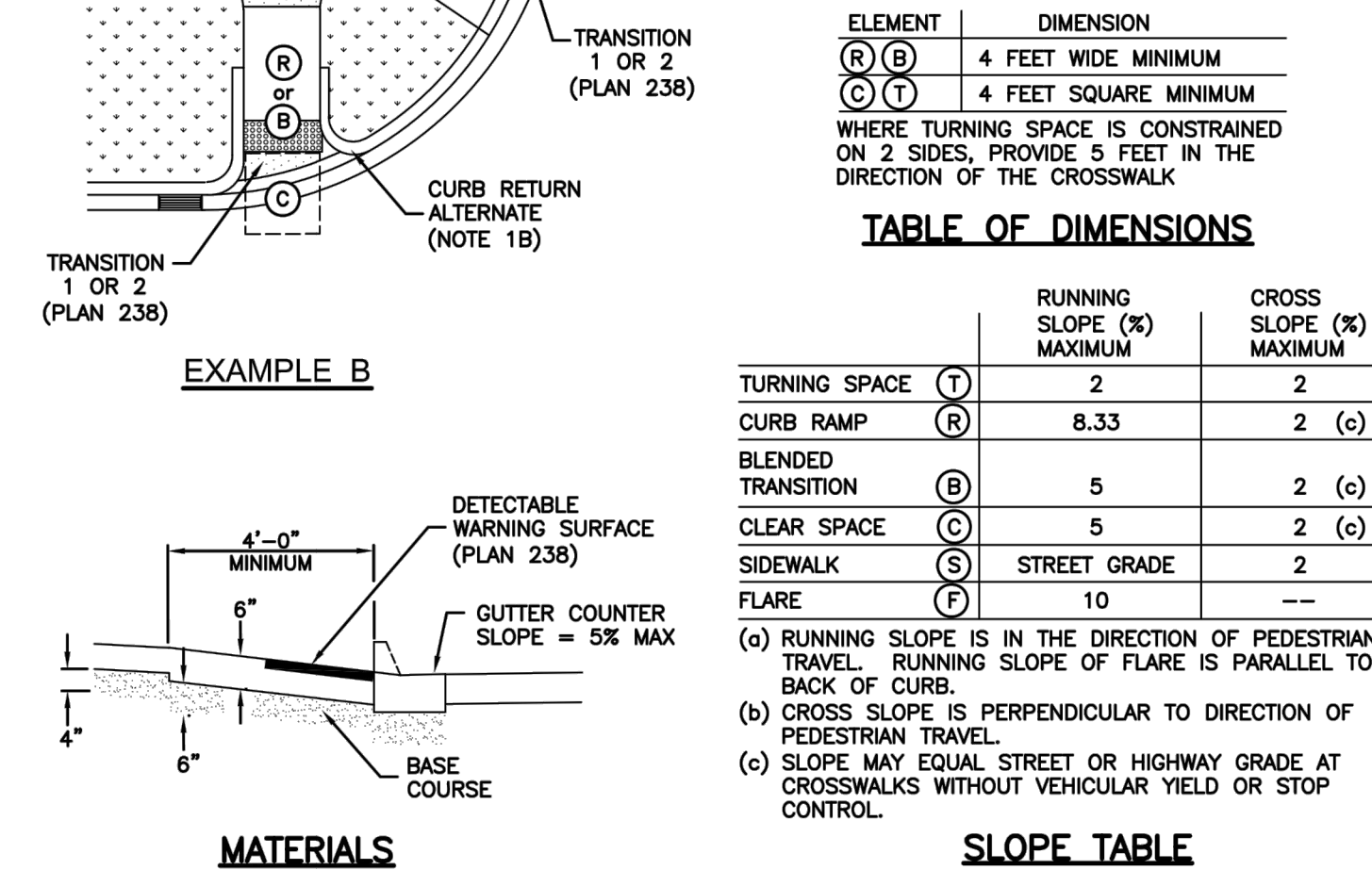
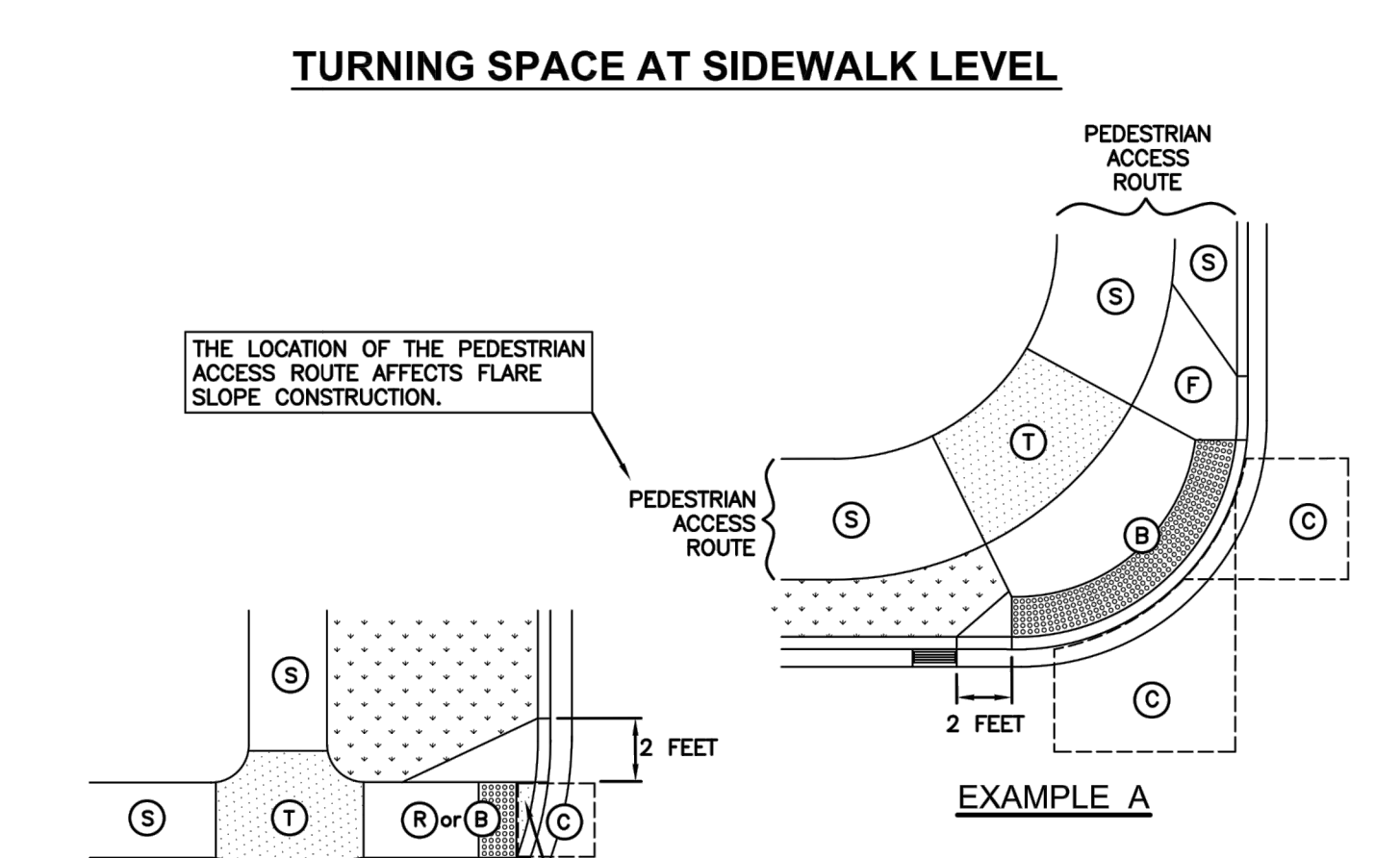

7 CORNER CURB CUT ASSEMBLY
SCALE: N.T.S.

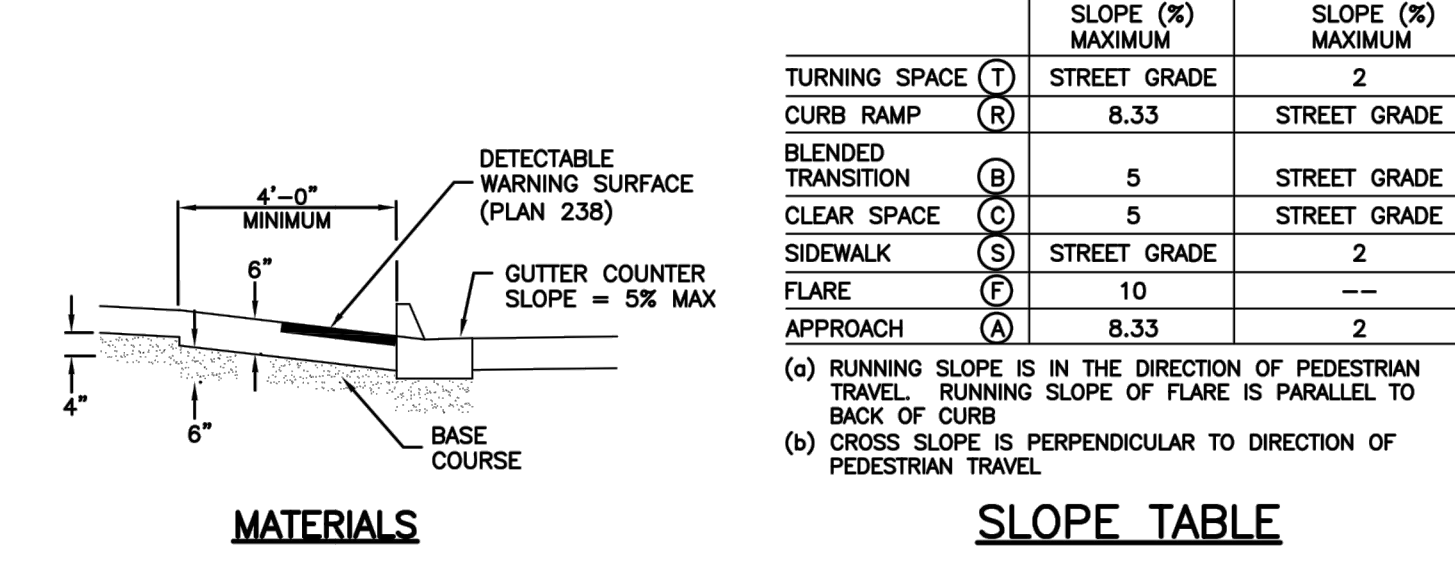
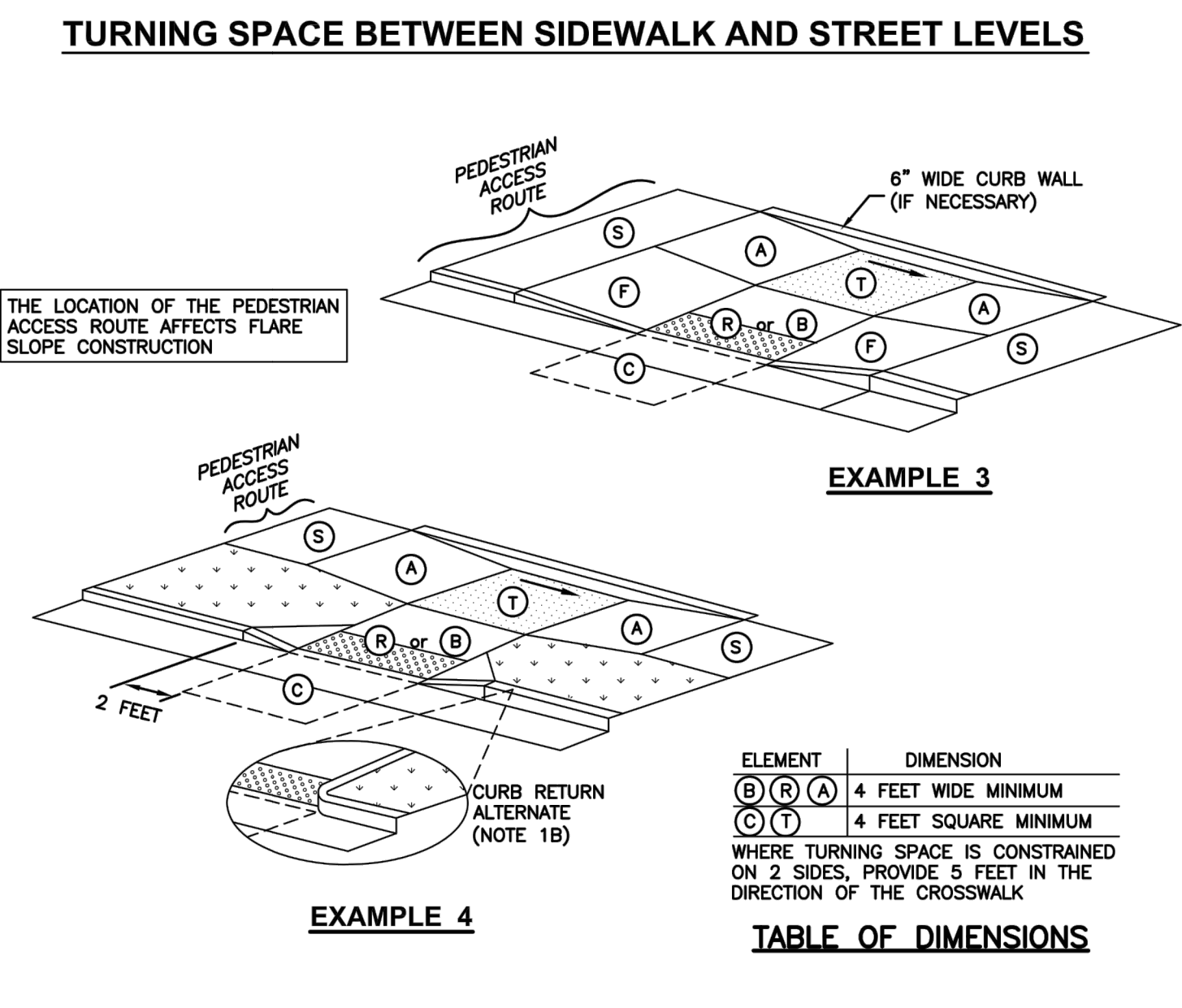

6 MIDBLOCK CURB CUT ASSEMBLY (2)
SCALE: N.T.S.

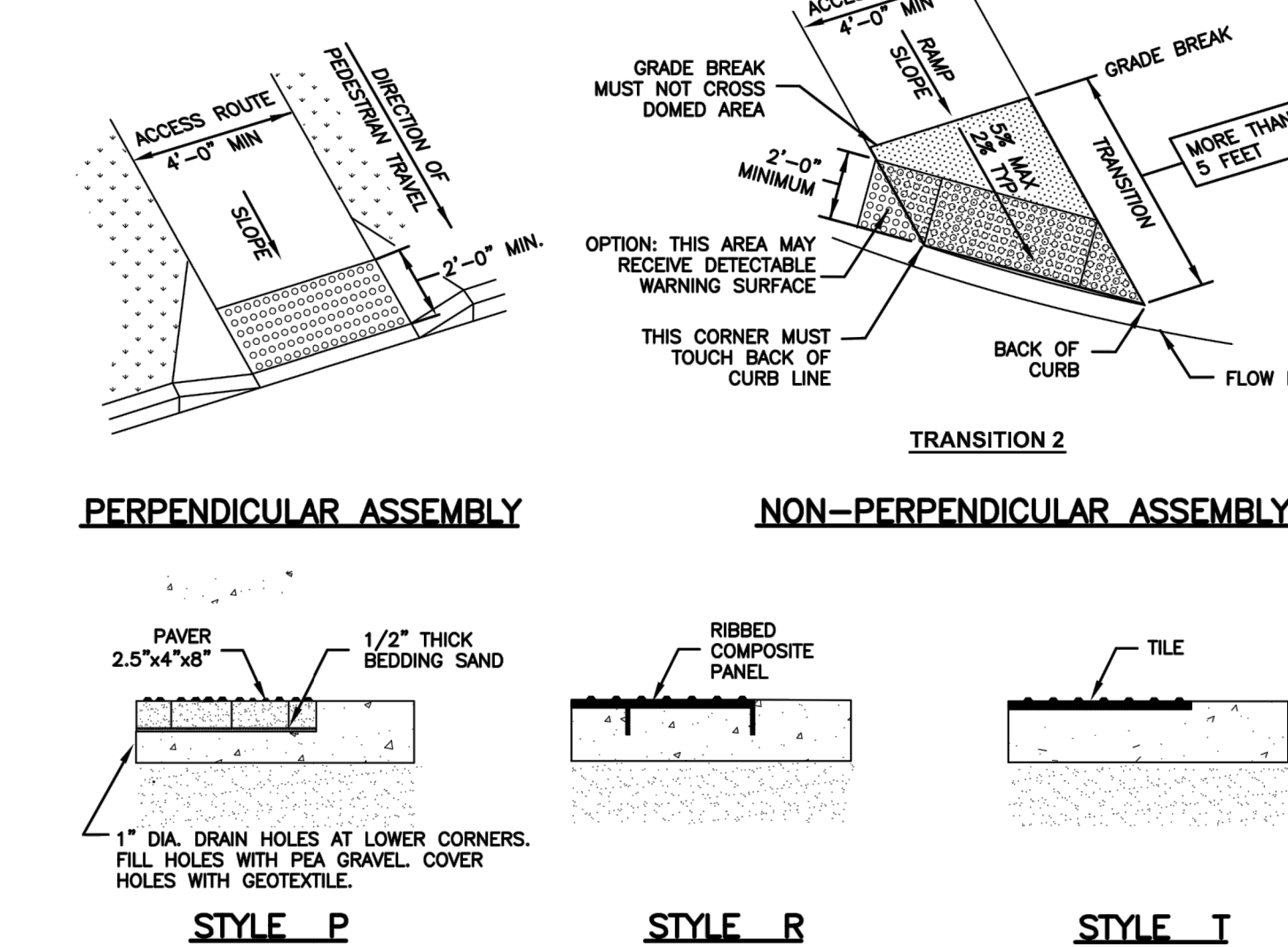
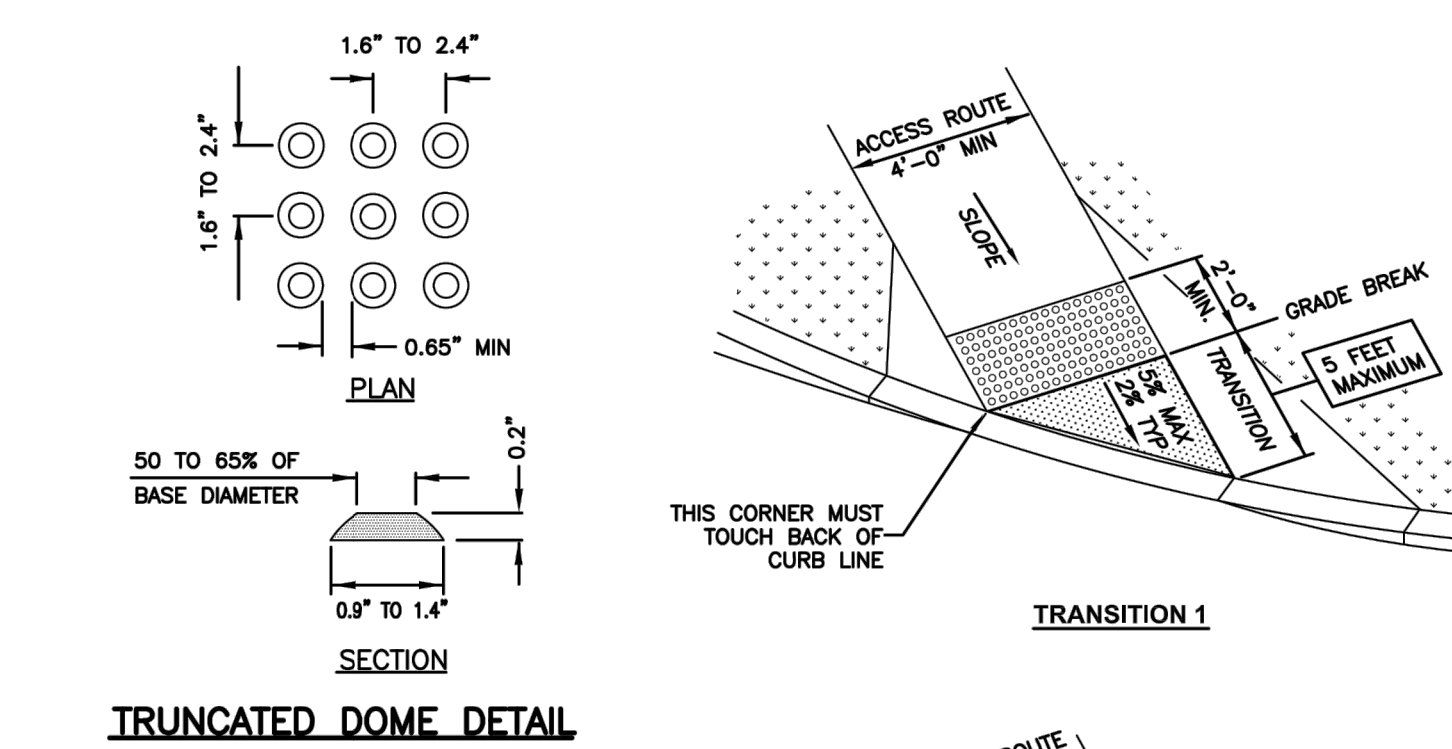

5 DETACHABLE WARNING SURFACE
SCALE: N.T.S.

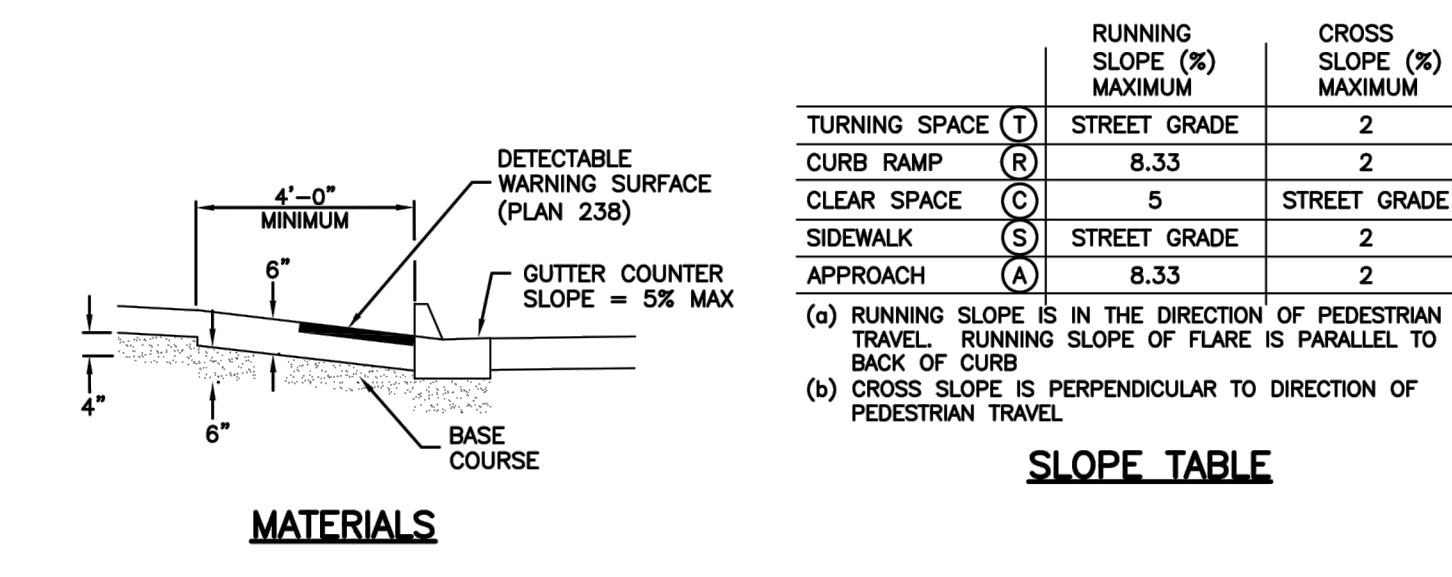
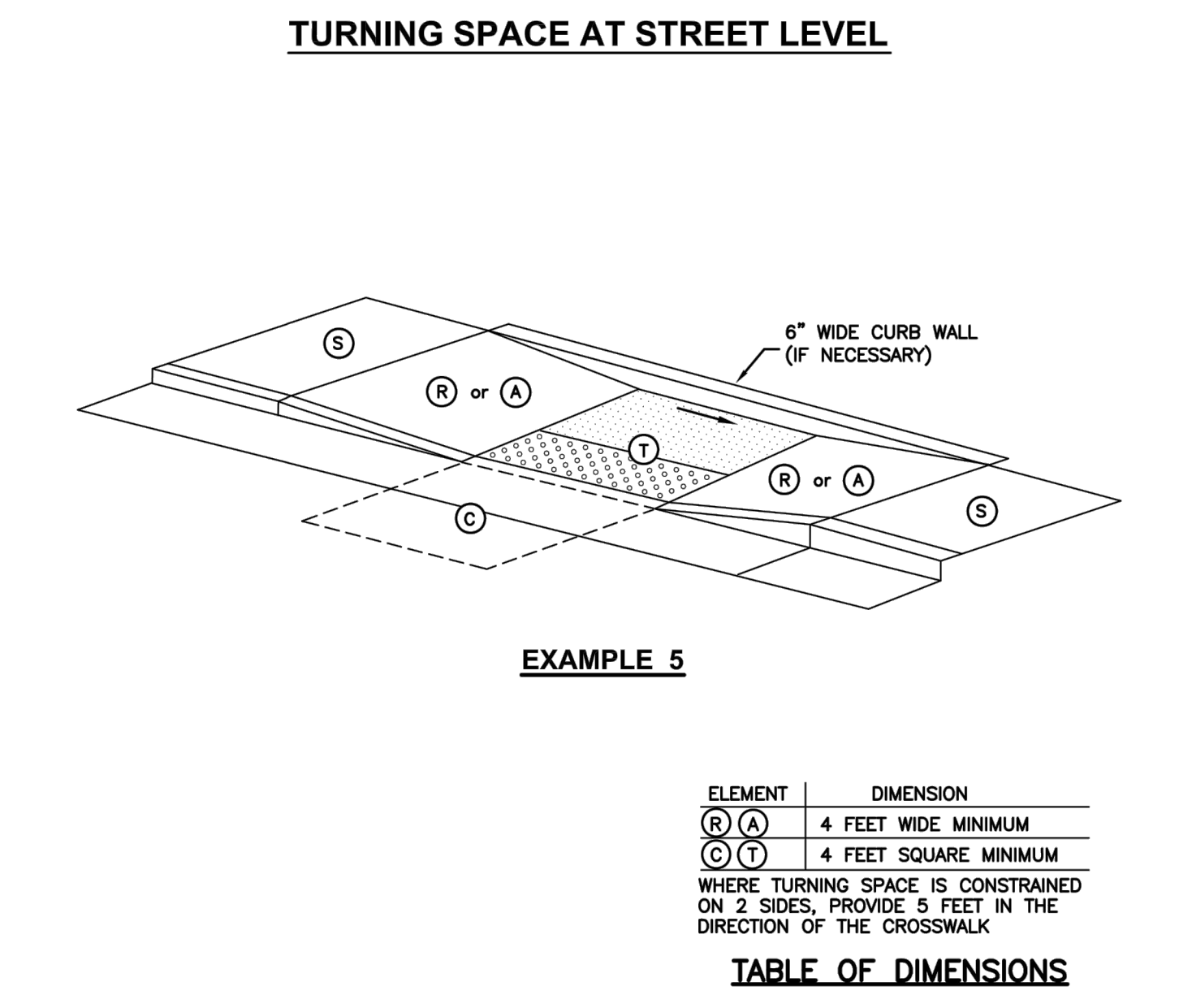

4 MIDBLOCK CURB CUT ASSEMBLY (3)
SCALE: N.T.S.

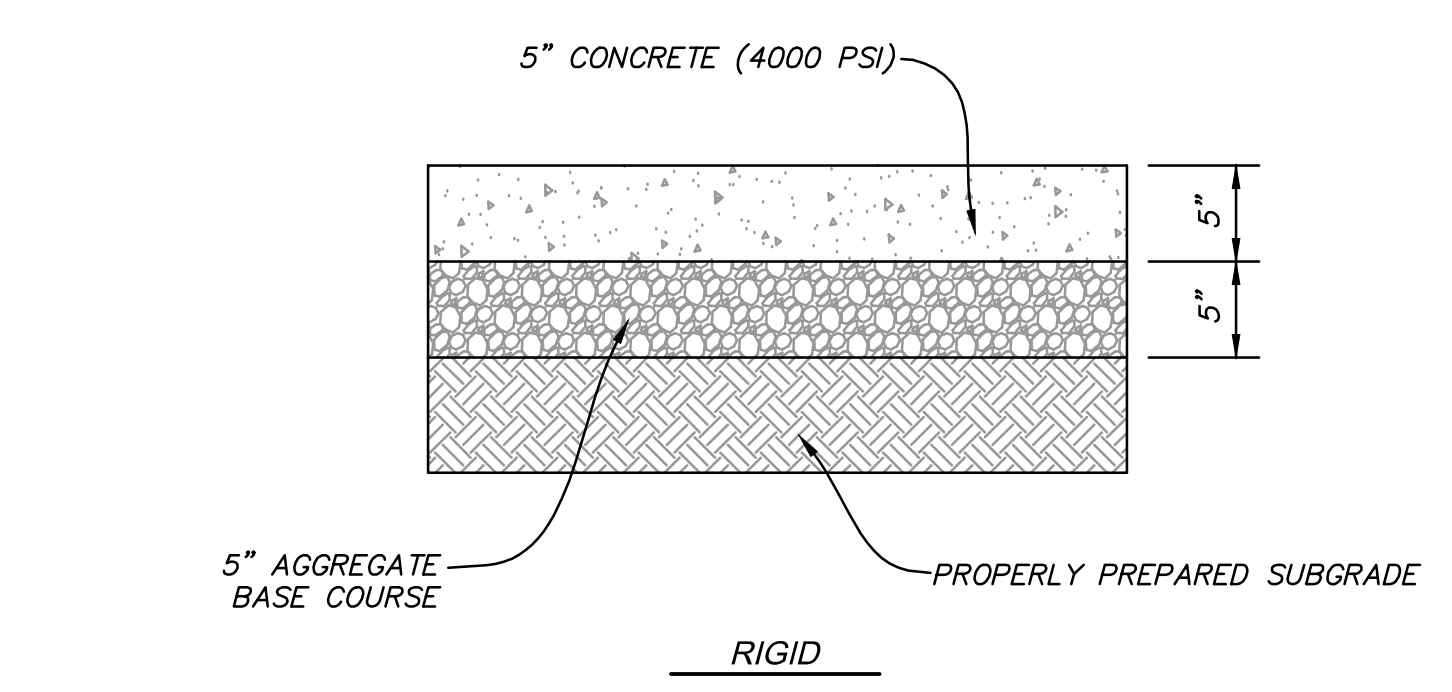
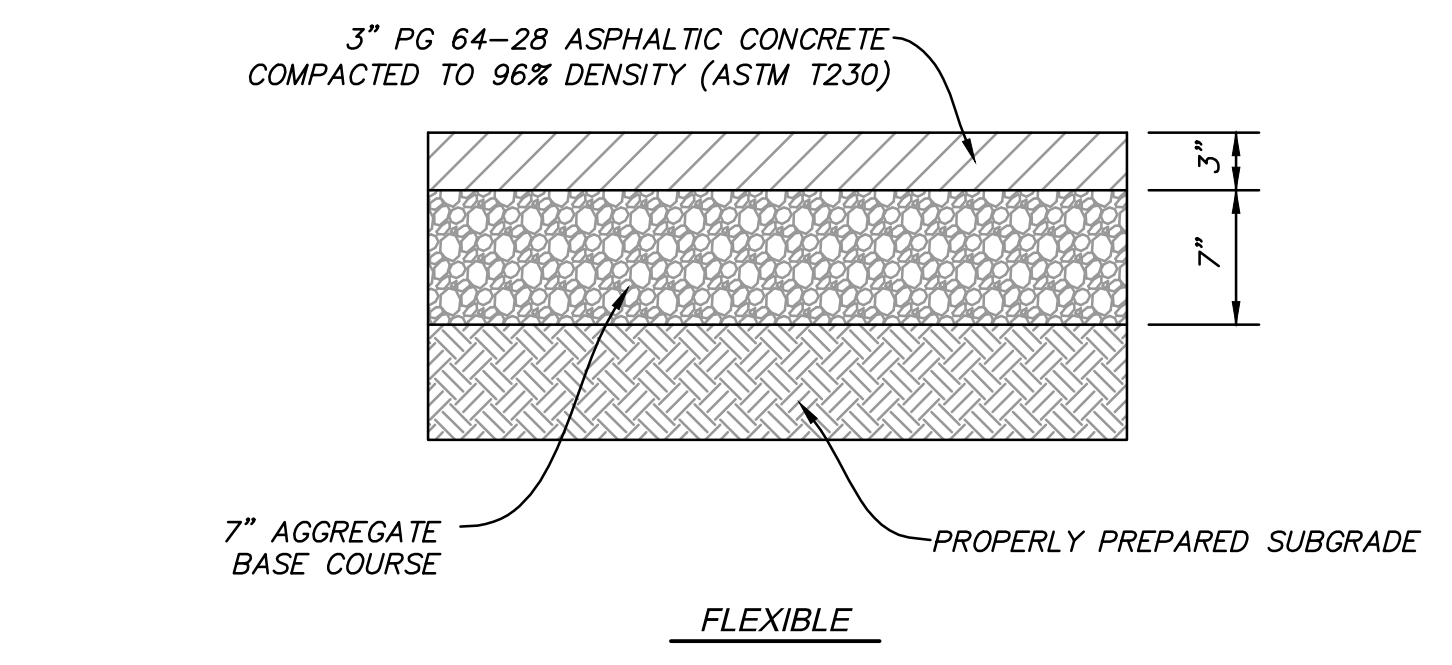

3 PARKING AREAS - LIGHT DUTY
SCALE: N.T.S.

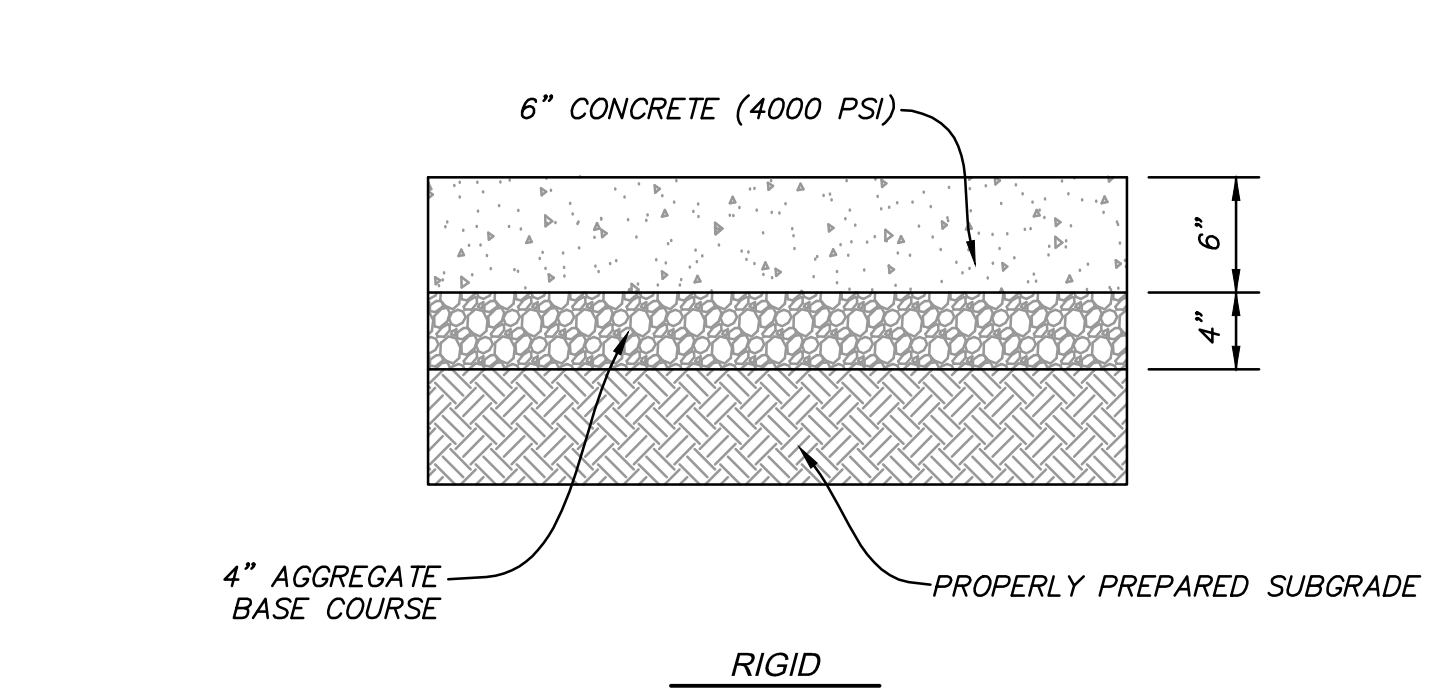
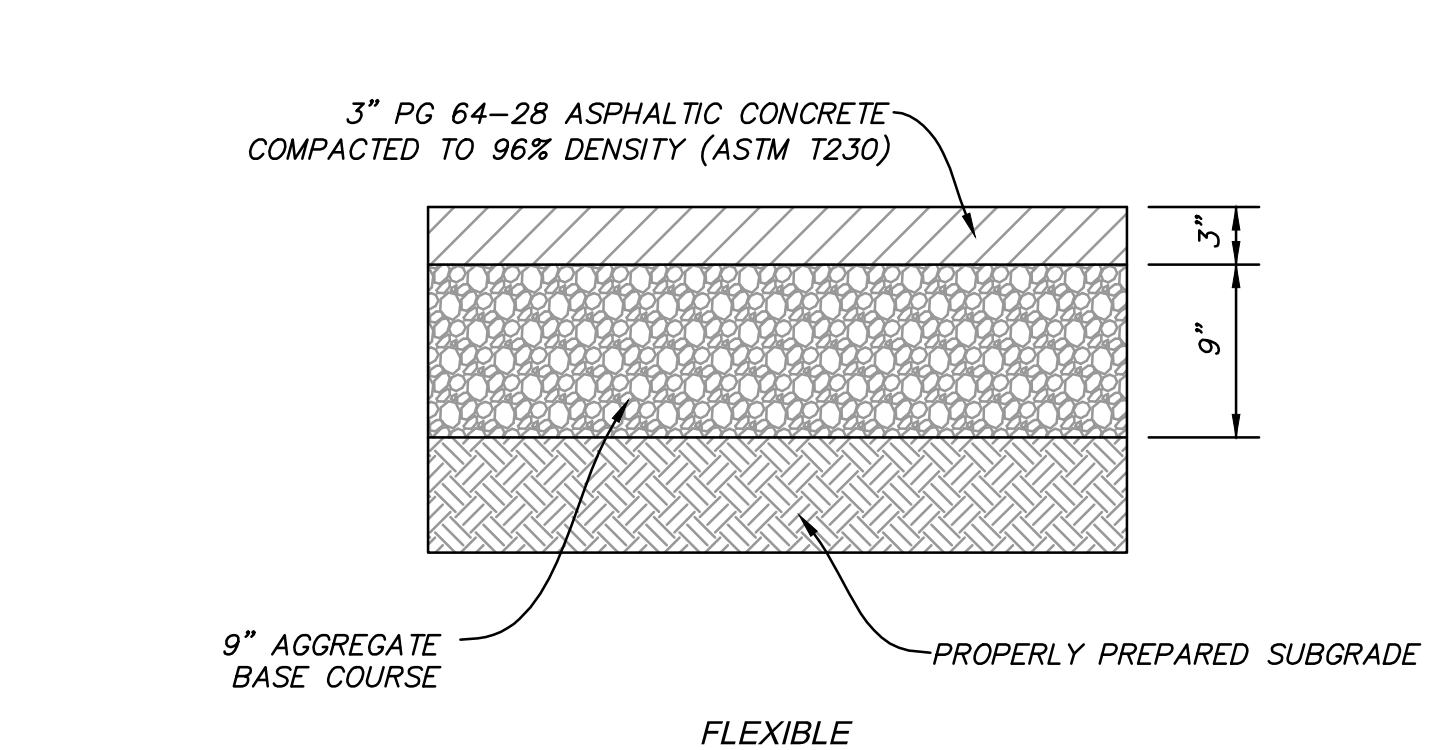

2 PRIMARY ROADS - MEDIUM DUTY
SCALE: N.T.S.

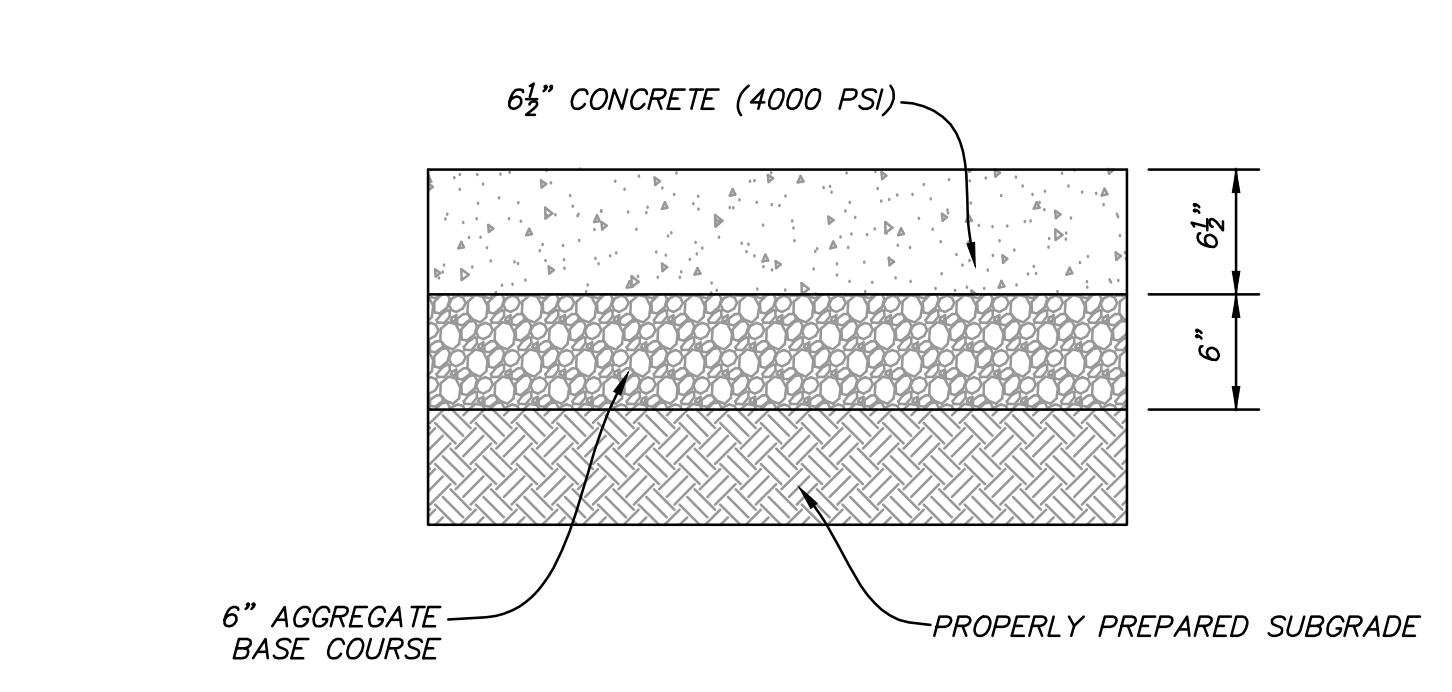
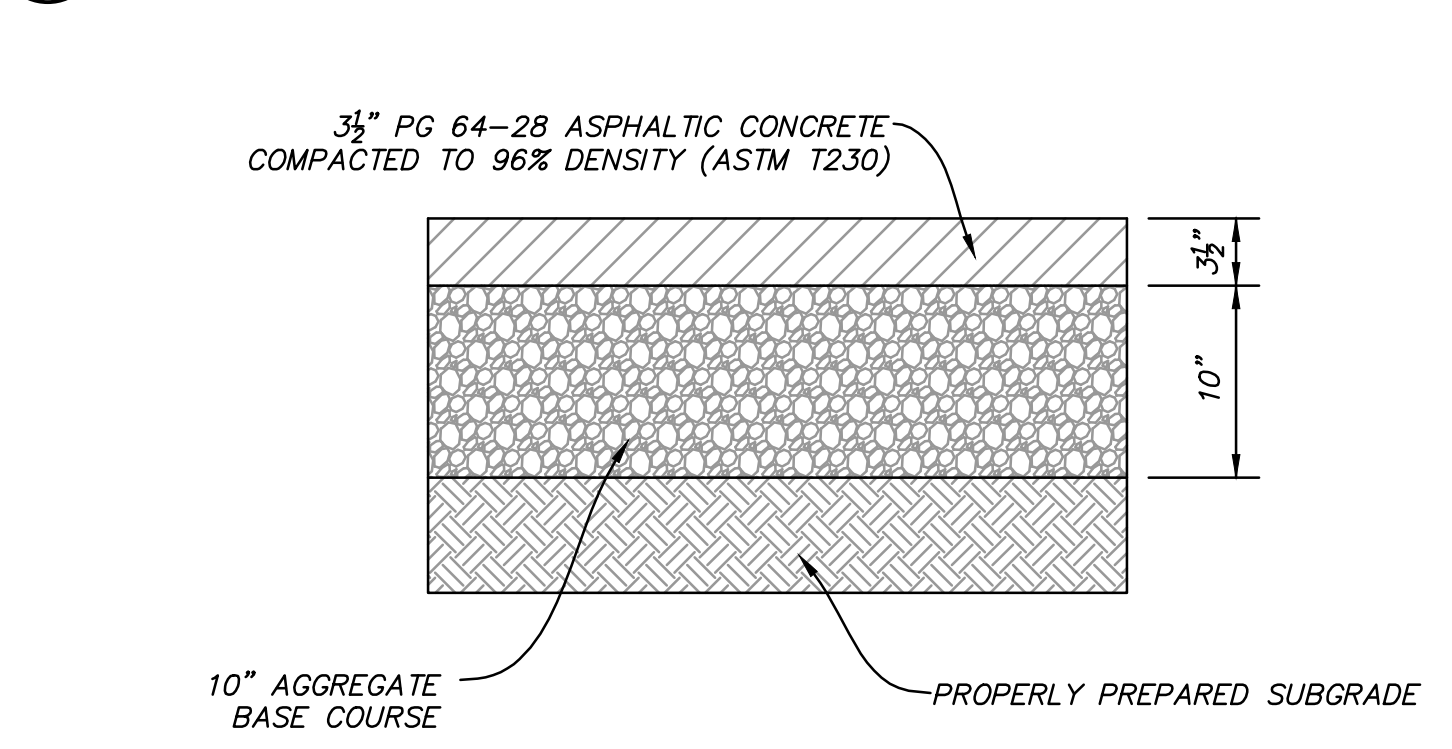

1 BUS ROADS AND PARKING - HEAVY DUTY
SCALE: N.T.S.

MHTN ARCHITECTS
MHTN Architects, Inc.
420 East South Temple
Suite 100
Salt Lake City, Utah 84111
Telephone (801) 595-6700
Telefax (801) 595-6717
www.mhtn.com

NV5
BEYOND ENGINEERING
5217 So. State Street
Suite 200
Murray, Utah 84107
801-743-1300

WEBER SCHOOL DISTRICT

WEST WEBER ELEMENTARY
WEBER SCHOOL DISTRICT
4178 WEST 900 SOUTH OGDEN, UT AND 84404

2011 MHTN ARCHITECTS, INC.
Drawings, written material, and design concepts shall not be used or reproduced in whole or part in any form or format without prior written consent of MHTN ARCHITECTS, INC. © 2011 MHTN ARCHITECTS, INC. All rights reserved. If not shown, verify correct dimensions with the Architect. Contractor shall check and verify all dimensions and conditions at job site.

MHTN PROJECT NO. 2012545.00
DRAWN BY: Author CHECKED BY: Checker

ISSUED	NO.	DATE	DESCRIPTION

CONTRACTOR TO VERIFY DRAWINGS IN FIELD USE REFLECT LAST REVISION DATE

NO.	DATE	DESCRIPTION

SHEET NAME
SITE DETAILS

CONSTRUCTION DRAWINGS
SHEET NUMBER

CE-602

DATE: 12/21/13 TIME: 11:06:17 AM DRAWING NAME: CE-602.DWG
SHEET: MAKE SETUP LAYOUT: NDS - CH
PLOT: N:\SUBPROJECTS\13\130422_WEBER_ELEMENTARY\130422_WEBER_ELEMENTARY.dwg PLOT DATE: 12/21/13 11:06:17 AM