

THE RIDGE TOWNHOMES PHASE 1

PART OF THE NORTHEAST 1/4 OF SECTION 27
T7N, R1E, SLB & M, U.S. SURVEY
WEBER COUNTY, UTAH

MARCH 2014

UNITS 1 - 4

UNITS 5 - 8



LINE TABLE		
LINE #	LENGTH	BEARING
L1	6.208	N18° 08' 52"E
L2	2.000	S71° 51' 08"E
L3	17.704	N18° 08' 52"E
L4	8.290	S76° 51' 08"E
L5	12.321	S76° 51' 08"E
L6	5.322	N13° 08' 52"E
L7	2.963	N76° 51' 08"W
L8	12.980	N13° 08' 52"E
L9	6.838	S76° 51' 08"E
L10	12.459	N13° 08' 52"E
L11	13.839	S76° 51' 08"E
L12	0.999	N13° 08' 52"E
L13	7.740	S76° 51' 08"E
L14	1.000	S13° 08' 52"W
L15	2.837	S76° 51' 08"E
L16	12.458	S13° 08' 52"W
L17	2.500	S76° 51' 08"E
L18	3.327	S13° 08' 52"W
L19	9.173	S13° 08' 52"W
L20	21.384	S76° 51' 08"E
L21	6.314	S76° 51' 08"E
L22	9.227	N13° 08' 52"E
L23	2.589	S76° 51' 08"E
L24	12.354	N13° 08' 52"E
L25	4.562	S76° 51' 08"E
L26	2.000	N13° 08' 52"E
L27	10.208	S76° 51' 08"E
L28	1.917	S13° 08' 52"W
L29	9.542	S76° 51' 08"E
L30	6.250	S13° 08' 52"W
L31	2.250	N76° 51' 08"W
L32	7.894	S13° 08' 52"W
L33	10.268	N71° 51' 08"W
L34	15.288	N71° 51' 08"W
L35	0.667	N13° 08' 52"E
L36	15.713	N76° 51' 08"W
L37	5.000	N13° 08' 52"E
L38	13.667	N76° 51' 08"W
L39	2.146	S13° 08' 52"W
L40	2.833	N76° 51' 08"W
L41	2.146	N13° 08' 52"E
L42	13.906	N76° 51' 08"W
L43	3.792	S13° 08' 52"W
L44	2.635	N76° 51' 08"W
L45	1.792	N13° 08' 52"E

LINE TABLE		
LINE #	LENGTH	BEARING
L46	13.830	N76° 51' 08"W
L47	3.000	S13° 08' 52"W
L48	14.917	N76° 51' 08"W
L49	5.042	N13° 08' 52"E
L50	29.303	N76° 51' 08"W
L51	5.546	N18° 08' 52"E
L52	2.208	N71° 51' 08"W
L53	0.667	S13° 08' 52"W
L54	16.916	S76° 51' 08"E
L55	49.042	S13° 08' 52"W
L56	0.458	S76° 51' 08"E
L57	15.715	S13° 08' 52"W
L58	7.229	N76° 51' 08"W
L59	4.375	S13° 08' 52"W
L60	7.229	N76° 51' 08"W
L61	15.119	S13° 09' 33"W
L62	44.436	N12° 55' 58"E
L63	17.438	S76° 51' 08"E
L64	9.310	N76° 51' 08"W
L65	7.758	N13° 08' 52"E
L66	20.010	N76° 41' 09"W
L67	1.818	N12° 52' 07"E
L68	16.453	N76° 41' 09"W
L69	3.074	S13° 12' 22"W
L70	2.762	N11° 02' 40"E
L71	16.399	N76° 31' 26"W
L72	9.706	S76° 51' 08"E
L73	7.971	N13° 18' 51"E
L74	25.037	N71° 41' 09"W
L75	7.640	N12° 49' 20"E
L76	17.129	N76° 02' 53"W
L77	27.699	N76° 57' 45"W
L78	9.342	N76° 16' 44"W
L79	5.416	N13° 18' 51"E
L80	2.774	S12° 48' 13"W
L81	8.226	S13° 18' 51"W
L82	12.437	S13° 08' 52"W
L83	6.937	S76° 51' 08"E
L84	12.958	S13° 08' 52"W
L85	2.558	N76° 51' 08"W
L86	7.880	S13° 08' 52"W
L87	19.729	S76° 51' 08"E
L88	17.347	S13° 08' 52"W
L89	2.042	S76° 51' 08"E

LINE TABLE		
LINE #	LENGTH	BEARING
L84	6.208	N28° 52' 55"E
L85	2.000	S61° 07' 05"E
L86	17.704	N28° 52' 55"E
L87	8.308	S66° 07' 05"E
L88	12.303	S66° 07' 05"E
L89	5.322	N23° 52' 55"E
L90	2.963	N66° 07' 05"W
L91	12.980	N23° 52' 55"E
L92	6.838	S66° 07' 05"E
L93	12.459	N23° 52' 55"E
L94	13.839	S66° 07' 05"E
L95	0.999	N23° 52' 55"E
L96	7.740	S66° 07' 05"E
L97	1.000	S23° 52' 55"W
L98	2.837	S66° 07' 05"E
L99	12.458	S23° 52' 55"W
L100	2.500	S66° 07' 05"E
L101	3.447	S25° 00' 53"W
L102	9.054	S23° 27' 02"W
L103	21.384	S66° 07' 05"E
L104	6.314	S66° 07' 05"E
L105	9.227	N23° 52' 55"E
L106	2.589	S66° 07' 05"E
L107	12.354	N23° 52' 55"E
L108	4.563	S66° 07' 05"E
L109	2.000	N23° 52' 55"E
L110	10.208	S66° 07' 05"E
L111	1.917	S23° 52' 55"W
L112	9.542	S66° 07' 05"E
L113	2.042	S66° 07' 05"E
L114	6.250	S23° 52' 55"W
L115	2.250	N66° 07' 05"W
L116	7.894	S23° 52' 55"W
L117	25.556	N61° 07' 05"W
L118	0.667	N23° 52' 55"E
L119	15.713	N66° 07' 05"W
L120	5.000	N23° 52' 55"E
L121	13.667	N66° 07' 05"W
L122	2.146	S23° 52' 55"W
L123	2.833	N66° 07' 05"W
L124	2.146	N23° 52' 55"E
L125	13.906	N66° 07' 05"W
L126	3.792	S23° 52' 55"W
L127	2.635	N66° 07' 05"W
L128	1.792	N23° 52' 55"E

LINE TABLE		
LINE #	LENGTH	BEARING
L129	13.830	N66° 07' 05"W
L130	3.000	S23° 52' 55"W
L131	14.917	N66° 07' 05"W
L132	5.042	N23° 52' 55"E
L133	29.303	N66° 07' 05"W
L134	5.546	N28° 52' 55"E
L135	2.208	N61° 07' 05"W
L136	0.667	N23° 52' 55"E
L137	16.916	S66° 07' 05"E
L138	49.042	S23° 52' 55"W
L139	0.458	S66° 07' 05"E
L140	15.715	S23° 52' 55"W
L141	7.229	N66° 07' 05"W
L142	4.375	S23° 52' 55"W
L143	7.229	N66° 07' 05"W
L144	15.119	S23° 53' 36"W
L145	17.438	N66° 07' 05"W
L146	44.436	S23° 40' 01"W
L147	9.310	N23° 52' 55"E
L148	7.758	N13° 08' 52"E
L149	20.010	N76° 41' 09"W
L150	1.818	N12° 52' 07"E
L151	16.453	N76° 41' 09"W
L152	3.074	S13° 12' 22"W
L153	2.762	N11° 02' 40"E
L154	16.399	N76° 31' 26"W
L155	9.706	S76° 51' 08"E
L156	7.971	N13° 18' 51"E
L157	25.037	N71° 41' 09"W
L158	7.640	N12° 49' 20"E
L159	17.129	N76° 02' 53"W
L160	27.699	N76° 57' 45"W
L161	9.342	N76° 16' 44"W
L162	5.416	N13° 18' 51"E
L163	2.774	S12° 48' 13"W
L164	8.226	S13° 18' 51"W
L165	12.437	S13° 08' 52"W
L166	6.937	S76° 51' 08"E
L167	12.958	S13° 08' 52"W
L168	2.558	N76° 51' 08"W
L169	7.880	S13° 08' 52"W
L170	19.729	S76° 51' 08"E
L171	17.347	S13° 08' 52"W
L172	2.042	S76° 51' 08"E

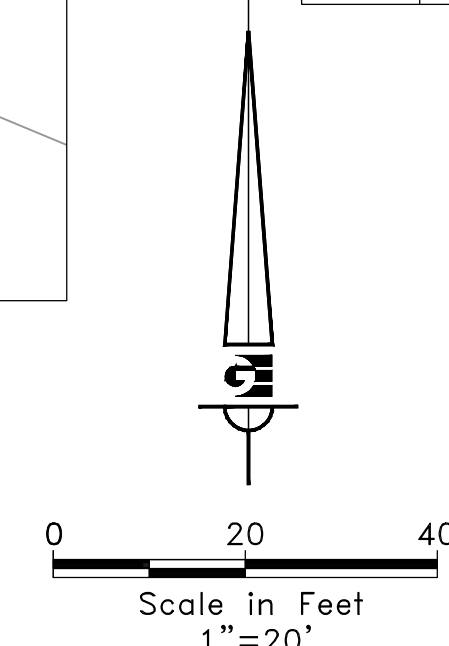

LEGEND

- SECTION LINE
- CENTERLINE
- RIGHT-OF-WAY LINE
- PROPERTY BOUNDARY
- PUBLIC UTILITY EASEMENT (PUE)
- BUILDING TIES
- PRIVATE
- LIMITED COMMON AREA
- COMMON AREA

Prepared By:



www.gardnerengineering.net

SHEET 2 OF 5

COUNTY RECORDER

ENTRY NO. _____ FEE PAID _____
 FILED FOR RECORD AND
 RECORDED _____, AT
 IN _____ BOOK OF OFFICIAL
 RECORDS, PAGE _____, RECORDED
 FOR _____
 COUNTY RECORDER
 BY: _____
 DEPUTY