

# Willson Estates Subdivision First Amendment

Weber County, Utah  
A Part of the Northeast Quarter of Section 7,  
Township 7 North, Range 1 East, Salt Lake Base & Meridian  
February 2014

### WEBER COUNTY SURVEYOR

I Herby Certify that the Weber County Surveyor's Office has Reviewed this Plat for Mathematical Correctness, Section Corner Data, and for Harmony with the Lines and Monuments on Record in County Offices. The Approval of this Plat by the Weber County Surveyor does not Relieve the Licensed Land Surveyor who Executed this Plat from the Responsibilities and/or Liabilities Associated Therewith.  
Signed this \_\_\_\_\_ Day of \_\_\_\_\_, 2014.

\_\_\_\_\_  
Weber County Surveyor

### WEBER-MORGAN HEALTH DEPARTMENT

I Herby Certify that the Soils, Percolation Rates, and Site Conditions for this Subdivision have been Investigated by this Office and are Approved for On-Site Wastewater Disposal Systems.  
Signed this \_\_\_\_\_ Day of \_\_\_\_\_, 2014.

\_\_\_\_\_  
Weber-Morgan Health Department

### WEBER COUNTY ATTORNEY

I Have Examined the Financial Guarantee and Other Documents Associated with this Subdivision Plat, and in my Opinion they Conform with the County Ordinance Applicable Thereto and now in Force and Effect  
Signed this \_\_\_\_\_ Day of \_\_\_\_\_, 2014.

\_\_\_\_\_  
Weber County Attorney

### WEBER COUNTY COMMISSION ACCEPTANCE

This is to Certify that this Subdivision Plat, the Dedication of Streets and other Public Ways and Financial Guarantee of Public Improvements Associated with this Subdivision, Thereon are Hereby Approved and Accepted by the Commissioners of Weber County Utah  
Signed this \_\_\_\_\_ Day of \_\_\_\_\_, 2014.

\_\_\_\_\_  
Chairman, Weber County Commission

Attest

### WEBER COUNTY PLANNING COMMISSION APPROVAL

This is to Certify that this Subdivision Plat was Duly Approved by the Weber County Planning Commission.  
Signed this \_\_\_\_\_ Day of \_\_\_\_\_, 2014.

\_\_\_\_\_  
Chairman, Weber County Planning Commission

### WEBER COUNTY ENGINEER

I Herby Certify that the Required Public Improvement Standards and Drawings for this Subdivision Conform with the County Standards and the Amount of the Financial Guarantee is Sufficient for the Installation of these Improvements.  
Signed this \_\_\_\_\_ Day of \_\_\_\_\_, 2014.

\_\_\_\_\_  
Weber County Engineer

Developer:  
Brad Wilson  
5626 North Fork Road  
Liberty, Utah  
(801) 726-0772

13-135 13-135v12 01/30/14

**HAI**  
HANSEN & ASSOCIATES, INC.  
Consulting Engineers and Land Surveyors  
538 North Main Street, Brigham, Utah 84302  
Visit us at [www.hais.net](http://www.hais.net)  
Brigham City Ogdan Logan  
(435) 723-3491 (801) 399-4905 (435) 752-8272

Trey Whitten  
220040048

John Mosey  
220040052

Paul Sealey  
220040145

Rogge Wilson  
220040141

Rogge Wilson  
222970002

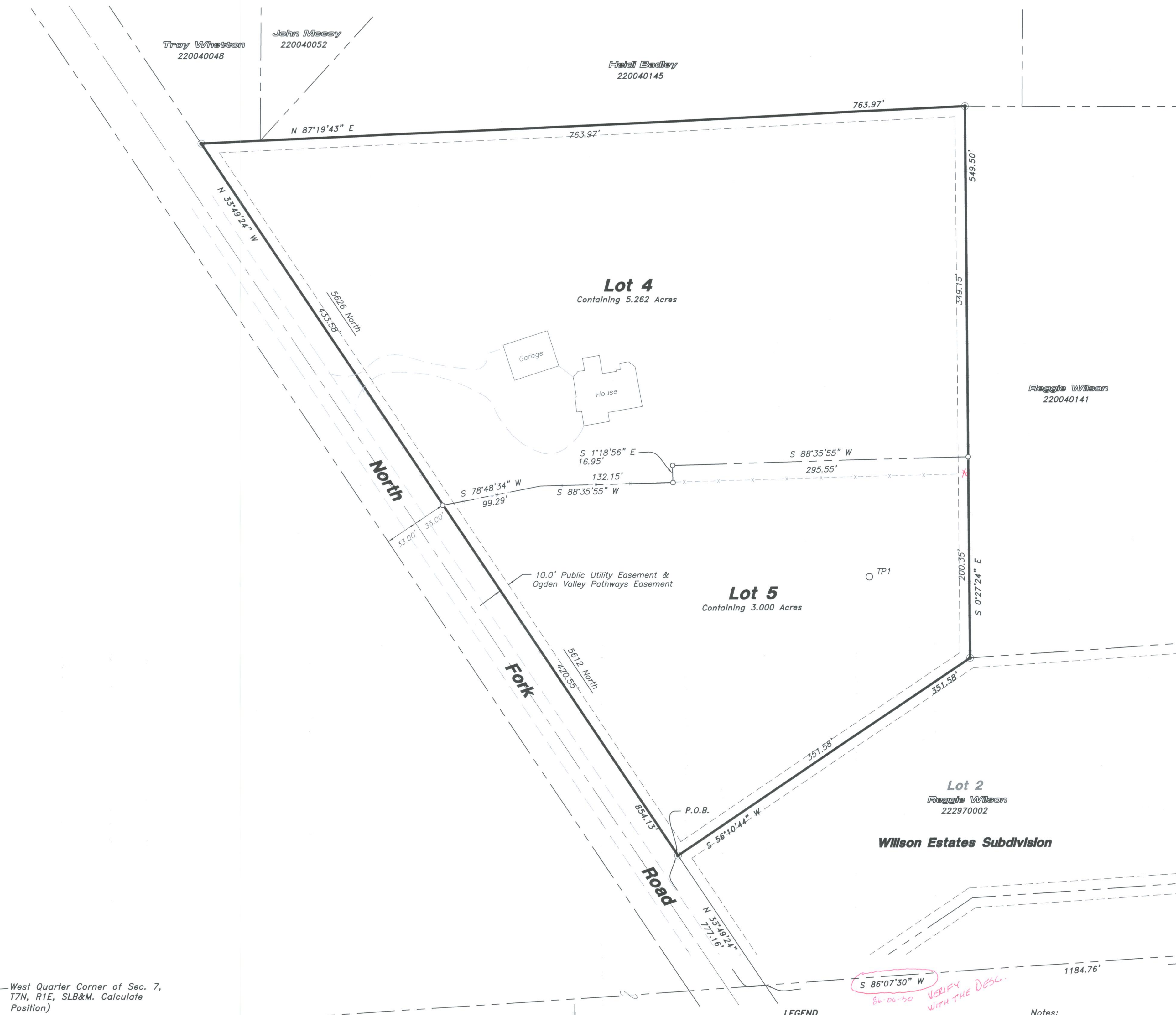

West Quarter Corner of Sec. 7,  
T7N, R1E, SLB&M. Calculate  
Position)

### NARRATIVE

The Purpose of this Survey was to Establish and set the Property Corners of the Amended Two Lot Subdivision as Shown and Described Hereon. This Survey was Ordered by Brad Wilson. This subdivision is the re-subdividing of Lot 1, Willson Estates Subdivision. The Control used to Establish the Property Corners was the Existing Weber County Surveyor Monumentation Surrounding Section 7, Township 7 North, Range 1 East, S.L.B.&M. The basis of bearing is the East line of the Northeast Quarter of said Section which bears North 00°15'41" East, Utah North, State Plane, Calculated N.A.D.83 Bearing.

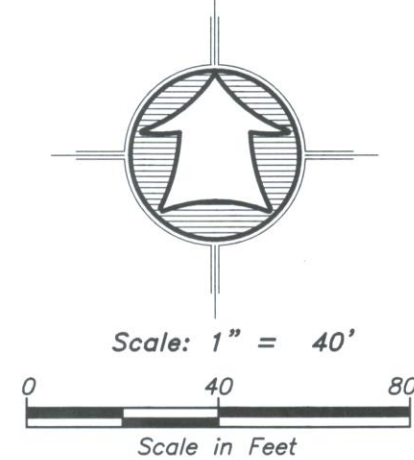

### LEGEND

- Subdivision Boundary Line
- Lot Line
- Adjoining property Line
- Public Utility Easement (P.U.E.)
- Easement
- Fence Line
- Edge of Asphalt/Concrete
- Section Corner
- Found HAI Rebar and Cap
- Set 5/8" by 24" Rebar With Cap

### Notes:

All Public Utility Easements (PUE) are 10.00 feet wide unless noted otherwise.

### AGRICULTURAL NOTE

Agriculture is the preferred use in the Agriculture Zones. Agriculture operations as specified in the zoning ordinance for a particular zone are permitted at any time including the operation of farm machinery and no allowed agriculture use shall be subject to restriction on that it interferes with activities of future residents of this subdivision

### SURVEYOR'S CERTIFICATE

I, K. Greg Hansen, do Herby Certify that I am a Registered Professional Land Surveyor in the State of Utah in Accordance with Title 58, Chapter 22, Professional Engineers and Land Surveyors Act; and I Have Completed a Survey of the Property Described on this Plat in Accordance with Section 17-23-17 and have Verified all Measurements, and have Placed Monuments as Represented on this Plat, and have Herby Amended said Tract into Two (2) Lots, know Hereafter as Willson Estates Subdivision First Amendment located in Weber County, Utah, and has been Correctly Drawn to the Designated Scale and is True and Correct Representation of the Herein Described Lands Included in said Subdivision, Based Upon Data Compiled from Records in the Weber County Recorder's Office and from said Survey made by me on the Ground, I Further Herby Certify that the Requirements of all Applicable Statutes and Ordinances of Weber County Concerning Zoning Requirements Regarding Lot Measurements have been Complied with.

Signed this \_\_\_\_\_ day of \_\_\_\_\_, 2014.

K. Greg Hansen P.L.S.  
Utah Land Surveyor Licence No. 167819



### BOUNDARY DESCRIPTION

A PART OF THE NORTHEAST QUARTER OF SECTION 7, TOWNSHIP 7 NORTH, RANGE 1 EAST OF THE SALT LAKE BASE AND MERIDIAN.

BEGINNING AT THE NORTHWEST CORNER OF LOT 2, WILLSON ESTATES SUBDIVISION RECORDED AS ENTRY NO. 2390767 IN THE OFFICE OF THE WEBER COUNTY RECORDER, BEING A POINT ON THE EASTERLY RIGHT-OF-WAY LINE OF NORTH FORK ROAD LOCATED 1184.76 FEET SOUTH 86°06'30" WEST AND 777.16 FEET NORTH 33°49'24" WEST FROM THE EAST QUARTER CORNER OF SAID SECTION 7; RUNNING THENCE ALONG THE BOUNDARY LINE OF THE NOW VACATED LOT 1 OF SAID WILLSON ESTATES SUBDIVISION THE FOLLOWING FOUR (4) COURSES; NORTH 33°49'24" WEST 854.13 FEET ALONG SAID EASTERLY RIGHT-OF-WAY LINE; (2) NORTH 87°19'43" EAST 763.97 FEET; (3) SOUTH 00°27'24" EAST 549.50 FEET TO AN ANGLE POINT IN THE NORTH BOUNDARY LINE OF SAID LOT 2; AND (4) SOUTH 56°10'44" WEST 351.58 FEET TO THE POINT OF BEGINNING, CONTAINING 8.262 ACRES AND TWO LOTS.

### OWNER'S DEDICATION AND CERTIFICATION

Know all men by these presents that we, the undersigned Owners of the above described tract of land having caused the same to be subdivided into lots and streets, as shown on this plat and name said tract Willson Estates Subdivision First Amendment and hereby dedicate, grant and convey, in perpetuity, pursuant to the provisions of 10-9a-607, Utah code, without condition, restriction or reservation to Weber County, Utah, all those parts or portions of said tract of land designated as streets the same to be used as public thoroughfares forever, and also dedicate to Weber County those certain strips as easements for public utility and drainage purposes as shown hereon. The same to be used for the installation, maintenance and operation of public utility service lines and drainage as may be authorized by the Governing Authority in witness we have here unto set our signature this \_\_\_\_\_ day of \_\_\_\_\_, 2014.

\_\_\_\_\_  
Jami Willson Trustee of the Jami Willson Living Trust

### TRUST ACKNOWLEDGMENT

State of Utah  
County of \_\_\_\_\_  
On this \_\_\_\_\_ day of \_\_\_\_\_, 2014.

Trustee for the Jami Willson Living trust, personally appeared before me, the undersigned notary public in and for said county, in the state of Utah, the signers of the attached owners dedication, one in numbers, who duly acknowledged to me they signed it freely and voluntarily and for the purpose therein mentioned on behalf of said trust.

\_\_\_\_\_  
Notary public

East Quarter Corner of Sec. 7,  
T7N, R1E, SLB&M. Found Weber  
Co. Brass Cap Mon. 1963.  
Fair Condition

### WEBER COUNTY RECORDER

ENTRY NO. \_\_\_\_\_ FEE PAID \_\_\_\_\_  
FILED FOR RECORD AND  
RECORDED \_\_\_\_\_  
IN BOOK \_\_\_\_\_ OF OFFICIAL  
RECORDS, PAGE \_\_\_\_\_ RECORDED  
FOR \_\_\_\_\_

\_\_\_\_\_  
COUNTY RECORDER

BY: \_\_\_\_\_  
DEPUTY