

SWPPP for Weber Industrial Park - Flex Building

Instructions to the Contractor:

Please familiarize yourself with the SWPPP document and fill in blanks with additional information such as Operator/SWPPP Contact/Stormwater Team names, phone numbers and e-mails, as well as start/end dates, training personnel, inspection schedule, and any other needed information throughout the document. Please submit an NOI and include a copy of the letter from the state notifying you of their receipt of your complete NOI/application in Appendix B. Fill in information in Section 9.2 of this document any time there are revisions to the document. Certifications found in Section 10 are required per Part 9.16.1 of the UCGP. This should be signed by a corporate officer, president, general partner, or similar per Part 9.16.1.a, or a duly authorized representative made in writing. If there are multiple authorized Owners/Operators, please make additional copies of the Certification so that all may sign.

Please place this page in Appendix G after completing the above items.

Storm Water Pollution Prevention Plan

for:

Weber Industrial Park - Flex Building
2147 Rulon White Boulevard
Ogden City, Utah 84404

Operator:

Company/Organization: _____

Name: _____

Address: _____

Phone: _____

Email: _____

Primary SWPPP Contact

Company/Organization: _____

Name: _____

Address: _____

Phone: _____

Email: _____

SWPPP Preparation Date:

22 November 2022

UPDES Permit Tracking Number*:

UTR _____

**This is the unique number assigned to your project after you have applied for coverage under the Utah Pollutant Discharge Elimination System (UPDES) construction general permit. If this template is filled out first, you can leave the tracking number blank until after you have applied for coverage.*

Contents

SECTION 1: CONTACT INFORMATION/ RESPONSIBLE PARTIES	1
1.1 Storm Water Team / SWPPP Writer & Qualification.....	1
SECTION 2: NATURE OF CONSTRUCTION ACTIVITIES	2
2.1 Construction Site Estimates	2
2.2 Construction Activity Descriptions	2
2.3 Phase/Sequence of Construction Activity.....	2
2.4 Maps	2
SECTION 3: WATER QUALITY	3
3.1 Discharge Information	3
3.2 Receiving Waters	3
3.3 Impaired Waters	3
3.4 High Water Quality	3
SECTION 4: POLLUTION PREVENTION STANDARDS	4
4.1 Potential Sources of Pollution.....	4
4.2 Non-Storm Water Discharges.....	4
4.3 Dewatering Practices	5
4.4 Natural Buffers or Equivalent Sediment Controls	5
SECTION 5: EROSION AND SEDIMENT CONTROLS – BMPS	7
5.1 List of Erosion and Sediment BMPs on Site.....	7
5.2 Linear Site Perimeter Control Exemption	8
5.3 Final Stabilization	11
SECTION 6: BMPS - POLLUTION PREVENTION/OPERATIONAL CONTROLS.....	13
6.1 Spill Prevention and Response	13
6.2 Pollution Prevention Controls	14
SECTION 7: SPECIAL CONDITIONS	19
7.1 Emergency Related Projects.....	19
7.2 UIC Class 5 Injection Wells.....	19
7.3 Chemical Treatment.....	19
SECTION 8: INSPECTIONS & CORRECTIVE ACTIONS	21
8.1 Inspections.....	21
8.2 Corrective Actions	21
8.3 Delegation of Authority	21
SECTION 9: RECORDKEEPING	22
9.1 Recordkeeping	22
9.2 Log of Changes to the SWPPP	22
SECTION 10: CERTIFICATION	23
Appendix A – Site Maps	
Appendix B – NOI	
Appendix C – Inspection Reports	
Appendix D –Corrective Action Report	
Appendix E – Subcontractor Certifications/Agreements/Delegation of Authority	
Appendix F – Training Logs (CGP Part 6) and Certifications	
Appendix G – Additional Information (i.e., Other permits and out of date SWPPP documents)	
Appendix H – BMP Specifications	
Appendix I – Construction General Permit	

SECTION 1: CONTACT INFORMATION/ RESPONSIBLE PARTIES

1.1 Storm Water Team / SWPPP Writer & Qualification

Name and/or Position, and Contact	Responsibilities, Qualifications, and Training
Responsible Person: Company Name: Position: Telephone Number: Email:	Responsibility(ies): Qualifications: Training:
Responsible Person: Company Name: Position: Telephone Number: Email:	Responsibility(ies): Qualifications: Training:
Responsible Person: Company Name: Position: Telephone Number: Email:	Responsibility(ies): Qualifications: Training:

This SWPPP was Originally Prepared by:

Great Basin Engineering
Ryan Bingham, P.E. (Civil)
5746 South 1475 East, Ste. 200
South Ogden, Utah 84403
Phone: 801-394-4515
Fax: 801-392-7544

SECTION 2: NATURE OF CONSTRUCTION ACTIVITIES

2.1 Construction Site Estimates

The following are estimates for the construction site.

Total project area (lot size):	1.5 acres
Construction site area to be disturbed:	1.5 acres

2.2 Construction Activity Descriptions

Describe the general scope of the work for the project, major phases of construction, etc:
Construction of a three-unit, 21,300 square foot new commercial building and associated site improvements will be accomplished with this project. Site work will include site grading, underground utilities, parking lots and other pavement, and some landscaping.

2.3 Phase/Sequence of Construction Activity

Construction will begin with clearing the site and stripping the surface. Underground utilities will be constructed, and the site will be rough graded. The footings for the building will then be constructed, followed by building construction and surface improvements. These surface improvements include asphalt and concrete pavement, curb and gutter and sidewalk and minimal landscaping. Two main phases for this project will be initial demolition/earthwork and proposed improvements. The BMPs for the work are listed on the SECP map, attached in Appendix A. See Appendix G for Contractor-supplied phasing schedule.

2.4 Maps

The General Location Map and Sediment and Erosion Control Plan map for the project are filed in Appendix A

SECTION 3: WATER QUALITY

3.1 Discharge Information

Does your project/site discharge storm water into a Municipal Separate Storm Sewer System (MS4)? Yes No

List the MS4 that receives the discharge from the construction project: Ogden City

3.2 Receiving Waters

Names of Receiving Waters

Name of Receiving Water (first surface water that receives storm water or where storm system discharges to)	Is the water impaired or high quality?	If high quality: Is it Category 1 or 2? If impaired: List pollutants that the waterbody is impaired for
1. Willard Bay Reservoir	<input checked="" type="checkbox"/> Not high quality/impaired <input type="checkbox"/> Impaired, has approved TMDL <input type="checkbox"/> Impaired, no TMDL <input type="checkbox"/> High quality	

3.3 Impaired Waters

The above-listed receiving water is not listed as being impaired due to pollutants. However, precautions should still be taken to reduce the probability of releasing pollutants to downstream surface waters. There are several precautions that can be taken to contribute to this. BMP Material Use may be utilized to ensure fertilizers are not overused and excess is swept onto landscaping or otherwise properly cleaned up. BMP Portable Toilets should be used, ensuring all four corners of each facility are staked to prevent tipping over.

3.4 High Water Quality

This site does not discharge to a surface water listed as being high water quality.

SECTION 4: POLLUTION PREVENTION STANDARDS

4.1 Potential Sources of Pollution

Pollutant-Generating Activity	Pollutants or Pollutant Constituents (that could be discharged if exposed to storm water)	Location on Site (or reference SWPPP site map where this is shown)
Paving	Concrete, Asphalt, Oils	Building and Parking Lot Areas
Solid Waste Storage and Disposal	Garbage/Trash	Staging Area and throughout the site.
Usage and Maintenance of Construction Vehicles	Fuels and Oils	Entire Site
Site Grading	Sediments	Entire Site

4.2 Non-Storm Water Discharges

Check allowable non-storm water discharges that are present and describe the measures used to reduce them or prevent them from contributing pollutants to discharges:

Authorized Non-Storm Water Discharges	Present	Comments/Controls
Discharges from emergency fire-fighting activities	<input type="checkbox"/> Y <input checked="" type="checkbox"/> N	
Fire hydrant flushing	<input checked="" type="checkbox"/> Y <input type="checkbox"/> N	Direct flushed water to settling basin to percolate or evaporate. Do not allow untreated storm water to enter storm drain system.
Properly managed landscape irrigation (excludes fertilizer injector systems)	<input type="checkbox"/> Y <input checked="" type="checkbox"/> N	
Properly managed vehicle and equipment wash water with no soaps, solvents, or detergents	<input checked="" type="checkbox"/> Y <input type="checkbox"/> N	Do not allow discharge of waters if soaps or detergents are used.
Water used to control dust	<input checked="" type="checkbox"/> Y <input type="checkbox"/> N	Utilize appropriate application rate. Do not over-water areas for dust control.
Drinking water, includes uncontaminated water line flushing	<input checked="" type="checkbox"/> Y <input type="checkbox"/> N	Use only uncontaminated water for line flushings, etc.
External building washdown with no soaps, solvents, detergents, or hazardous substances	<input type="checkbox"/> Y <input checked="" type="checkbox"/> N	
Pavement wash waters with no detergents or toxic or hazardous materials. Must have a	<input checked="" type="checkbox"/> Y <input type="checkbox"/> N	Utilize Sediment Trap if pavement washing is used.

sediment basin, sediment trap, of similarly effective control prior to discharge.		
Uncontaminated air conditioning or compressor condensate	<input type="checkbox"/> Y <input checked="" type="checkbox"/> N	
Uncontaminated, non-turbid discharges of ground water (from natural sources) or spring water	<input type="checkbox"/> Y <input checked="" type="checkbox"/> N	
Uncontaminated foundation or footing drains	<input type="checkbox"/> Y <input checked="" type="checkbox"/> N	

4.3 Dewatering Practices

Check box if section not applicable to this site

Describe the general scope of dewatering practices for the project and any BMPs used to manage the dewatering practices:

Utilize only percolation and/or evaporation as a means of release for any water removed as a result of dewatering for water encountered in trenches, foundations, or similar work.

BMP DO: Dewatering Operations

<i>Installation Schedule:</i>	Utilize throughout any activities that are found to require dewatering. Ensure that a dewatering permit is obtained before any dewatering takes place. Insert permit in Appendix G
<i>Maintenance and Inspection:</i>	Inspect BMPs each workday. Be proactive instead of reactive. Repair or replacement to take place upon discovery of the failure of the BMP
<i>Responsible Staff:</i>	Provided by Contractor
<i>Design Specifications and Drawings:</i>	See corresponding BMP details in Appendix H

4.4 Natural Buffers or Equivalent Sediment Controls

Buffer Compliance Alternatives

Are there any surface waters within 50 feet of your project's earth disturbances?

YES NO

List the water body: An unnamed ditch just west of the west property boundary. The site slopes to the east, but the unnamed ditch is on the west.

Check the compliance alternative that you have chosen:

I will provide and maintain a 50-foot undisturbed natural buffer around the surface water.

It is infeasible to provide and maintain a full 50-foot undisturbed natural buffer. I will provide and implement erosion and sediment controls to achieve the required sediment load reduction for my conditions.

- Reason that a 50' buffer could not be maintained:
- Width of buffer that will be retained:
- Additional controls used to achieve equivalent sediment load reduction of a 50' buffer:
- Description of the calculations and assumptions used to determine sediment load reductions:

The project qualifies as "small residential lot" disturbing less than an acre. The natural buffer is preserved in accordance with CGP A.2.3., storm water is treated by site erosion and sediment controls before discharge, natural buffers are shown on the site map, and buffer areas are marked on site. Select one of the 2 alternatives for small residential lots:

Alternative 1: Using Table A-1 in CGP for requirements

- Width of buffer that will be retained:
- Additional controls to be used:

Alternative 2: Using Tables A-2 through A-7 in CGP for requirements

- Width of buffer that will be retained:
- Sediment Risk Level Determined:
- Additional controls to be used:

I qualify for one of the exceptions in Part A.2.2. (If you have checked this box, provide information on the applicable buffer exception that applies, below.)

There is no discharge of storm water through the area between the disturbed portions of the site and the surface water that is located within 50 feet.

No natural buffer exists due to preexisting development disturbances that occurred prior to the initiation of planning for this project.

For a linear project, site constraints (e.g., limited right-of-way) make it infeasible for me to meet any of the compliance alternatives.

- Reason it is infeasible:
- Buffer width retained or supplemental controls used:

Buffer disturbances are authorized under a CWA Section 404 permit.

- Describe earth disturbances in buffer area:

Buffer disturbances will occur for the construction of a water-dependent structure or water access area (e.g., pier, boat ramp, and trail).

- Describe earth disturbances in buffer area:

SECTION 5: EROSION AND SEDIMENT CONTROLS – BMPS

5.1 List of Erosion and Sediment BMPs on Site

CGP Requirement	Example BMPs	EPA SWPPP Guide Section	BMPs Selected (Name and Reference Number if applicable)
Preserve vegetation where possible and direct storm water to vegetated areas when feasible (CGP 2.2.2.)	Phasing to minimize disturbance, signs/fences to protect areas not being disturbed.	Chapter 4, ESC Principle 1	PEV – Preservation of Existing Vegetation.
Install sediment controls along perimeter areas that receive pollutant discharges (CGP 2.2.3.).	Silt fence, fiber rolls, earth berms	Chapter 4, ESC Principle 7	SF – Silt Fence or GBB – Gravel Bag Berm
Minimize sediment track-out (CGP 2.2.4.)	Restrict access, stabilize exits, track-out pads, tire washing station, clean-up sediments	Chapter 4, ESC Principle 9	SCE – Stabilized Construction Entrance
Manage stockpiles with perimeter controls and locate away from storm water conveyances (CGP 2.2.5.)	Sediment barriers downgradient, proper location, covered stockpiles, diverting storm water from stockpiles	Chapter 4, ESC Principle 4	SM – Stockpile Management PC – Plastic Covering
Minimize dust (CGP 2.2.6.)	Water application, mulching, chemical dust suppression techniques		DC – Dust Controls
Minimize steep slope disturbance (CGP 2.2.7.)	Erosion control blankets, tackifiers, protect slopes from disturbance	Chapter 4, ESC Principle 5	PEV – Preservation of Existing Vegetation
Preserve topsoil (CGP 2.2.8.)	Stockpile topsoil	Chapter 4, ESC Principle 1	SM – Stockpile Management
Minimize soil compaction where final cover is vegetation (CGP 2.2.9.)	Restrict vehicle access, recondition soils before seeding		SF – Silt Fence or Other visible barrier may be used to restrict access to these locations
Protect storm drain inlets (CGP 2.2.10.)	Inserts, rock-filled bags, covers	Chapter 4, ESC Principle 6	IP/SB – Inlet Protection Silt Bags IP/GB – Inlet Protection Gravel Bags

Slow down runoff with erosion controls and velocity dissipation devices (CGP 2.2.11.)	Check dams, riprap	Chapter 4, ESC Principle 3	Not Used
Appropriately design any sediment basins or impoundments (CGP 2.2.12.)	Design to 2-year 24-hour storm or 3,600 cubic feet per acre drained, include design specifications	Chapter 4, ESC Principle 8	Not Used
Follow requirements for any treatment chemicals (polymers, flocculants, coagulants, etc.)	Store in leak proof containers and cover, proper training, minimize use		MS – Material Storage
Stabilize exposed portions of site with 14 days of inactivity (CGP 2.2.14).	Seeding, erosion control blankets, gravel, hydromulch	Chapter 9	SP – Seeding and Planting

BMP CS: Construction Sequencing

<i>Installation Schedule:</i>	Utilize during planning stages and follow plan throughout construction.
<i>Maintenance and Inspection:</i>	Modify written plan before any changes in construction activities are initiated.
<i>Responsible Staff:</i>	Provided by Contractor
<i>Design Specifications and Drawings:</i>	See corresponding BMP details in Appendix H

BMP DC: Dust Controls

<i>Installation Schedule:</i>	Use regularly as needed to prevent dust from leaving the site in the air.
<i>Maintenance and Inspection:</i>	Daily and as needed, ensure equipment used for dust controls is functioning properly. Inspect site weekly for areas of dust concern, and promptly utilize BMP DC as needed.
<i>Responsible Staff:</i>	Provided by Contractor
<i>Design Specifications and Drawings:</i>	See corresponding BMP details in Appendix H

<i>BMP ET: Employee Training</i>	
<i>Installation Schedule:</i>	Utilize before beginning work and at required intervals throughout project.
<i>Maintenance and Inspection:</i>	Promote clear identification of problems and identify solutions (BMPs). Integrate employee feedback into training and BMP implementation.
<i>Responsible Staff:</i>	Provided by Contractor
<i>Design Specifications and Drawings:</i>	See corresponding BMP details in Appendix H

<i>BMP IDC: Illegal Dumping Controls</i>	
<i>Installation Schedule:</i>	Implement measures to detect, correct, and enforce against illegal dumping of pollutants on streets, and into the storm drain system. Raise public awareness throughout project.
<i>Maintenance and Inspection:</i>	Establish tracking system to identify hot spots, patterns in time of occurrence, mode of dumping, and responsible parties. Look for trends and concentrate efforts accordingly.
<i>Responsible Staff:</i>	Provided by Contractor
<i>Design Specifications and Drawings:</i>	See corresponding BMP details in Appendix H

<i>BMP IP-SB: Silt Bags</i>	
<i>Installation Schedule:</i>	Before work begins upon existing inlets and immediately upon construction of new inlets.
<i>Maintenance and Inspection:</i>	Inspection after all storm events and as required between events.
<i>Responsible Staff:</i>	Provided by Contractor
<i>Design Specifications and Drawings:</i>	See corresponding BMP details in Appendix H

<i>BMP IP-GB: Gravel Bags</i>	
<i>Installation Schedule:</i>	Before work begins upon existing inlets and immediately upon construction of new inlets.
<i>Maintenance and Inspection:</i>	Inspect at least every 14 days and after storm events. Remove accumulated sediment when it reaches ½ bag height. Replace damaged bags and clean up spilled gravel.
<i>Responsible Staff:</i>	Provided by Contractor
<i>Design Specifications and Drawings:</i>	See corresponding BMP details in Appendix H

<i>BMP SS: Street Sweeping</i>	
<i>Installation Schedule:</i>	Utilize throughout construction.
<i>Maintenance and Inspection:</i>	Check streets and parking areas daily for sediment buildup from construction activity. Sweep when found.
<i>Responsible Staff:</i>	Provided by Contractor
<i>Design Specifications and Drawings:</i>	See corresponding BMP details in Appendix H
<i>BMP PEV: Preservation of Existing Vegetation</i>	
<i>Installation Schedule:</i>	Before Construction or Earthwork begins.
<i>Maintenance and Inspection:</i>	Maintenance requirements are low.
<i>Responsible Staff:</i>	Provided by Contractor
<i>Design Specifications and Drawings:</i>	See corresponding BMP details in Appendix H
<i>BMP SP: Seeding and Planting</i>	
<i>Installation Schedule:</i>	Provided by Landscaper
<i>Maintenance and Inspection:</i>	Adequate watering and fertilization shall be used. Grass shall be watered and mowed.
<i>Responsible Staff:</i>	Provided by Contractor
<i>Design Specifications and Drawings:</i>	See corresponding BMP details in Appendix H
<i>BMP SF: Silt Fence</i>	
<i>Installation Schedule:</i>	Install before any soil disturbance occurs.
<i>Maintenance and Inspection:</i>	Inspect immediately after any rainfall. Look for bypassing or undercutting and repair as required. Remove sediment that reaches one-half fence height.
<i>Responsible Staff:</i>	Provided by Contractor
<i>Design Specifications and Drawings:</i>	See corresponding BMP details in Appendix H

<i>BMP GBB: Gravel Bag Berm</i>	
<i>Installation Schedule:</i>	Install along perimeter of site before any soil disturbance occurs. Use on any areas where silt fence would be impractical.
<i>Maintenance and Inspection:</i>	Inspect immediately after any rainfall and a minimum of once every two weeks. Reshape or replace damaged bags immediately. Remove buildup of sediment.
<i>Responsible Staff:</i>	Provided by Contractor
<i>Design Specifications and Drawings:</i>	See corresponding BMP details in Appendix H

<i>BMP SCE: Stabilized Construction Entrance</i>	
<i>Installation Schedule:</i>	Install before any construction vehicles leave the site
<i>Maintenance and Inspection:</i>	Inspect entrance and adjacent roadway daily for sediment buildup and loss of gravel. Repair as required.
<i>Responsible Staff:</i>	Provided by Contractor
<i>Design Specifications and Drawings:</i>	See corresponding BMP details in Appendix H

<i>BMP SM: Stockpile Management</i>	
<i>Installation Schedule:</i>	Utilize when stockpiles are used. Locate away from drainage courses and inlets.
<i>Maintenance and Inspection:</i>	Conduct regular inspections during and after rainfall events.
<i>Responsible Staff:</i>	Provided by Contractor
<i>Design Specifications and Drawings:</i>	See corresponding BMP details in Appendix H

5.2 Linear Site Perimeter Control Exemption

Check box if section not applicable to this site

If the site is linear and perimeter controls are not feasible, describe other practices in use:

5.3 Final Stabilization

Description of final stabilization practices and schedule:

Type of stabilization (vegetation/landscaped, graveled, paved, etc.)	Location	Implementation Schedule
Seeding and Planting	See Landscaping Plan	As construction progress allows.
Structure	Building Location	Following Underground Utility Installation
Concrete/Asphalt	Sidewalks and parking lot	Following Building Construction

SECTION 6: BMPS - POLLUTION PREVENTION/OPERATIONAL CONTROLS

6.1 *Spill Prevention and Response*

Describe spill procedures and materials available for expeditious containment, clean-up and disposal of spills:

Keep Rags and/or absorbent material on-site for immediate cleanup and remediation. Do not hose down or bury contaminated soil or material. Utilize landfill or transfer station that is licensed to handle hazardous waste for disposal.

Identify the employee responsible for detection and response of spills and leaks:

Operator listed on NOI is responsible, unless delegated otherwise.

Any discharges in 24 hours equal to or in excess of the reportable quantities listed in 40 CFR 117, 40 CFR 110, and 40 CFR 302 will be reported to the National Response Center and the Division of Water Quality (DWQ) as soon as practical after knowledge of the spill is known to the permittees. The permittee shall submit within 14 calendar days of knowledge of the release a written description of: the release (including the type and estimate of the amount of material released), the date that such release occurred, the circumstances leading to the release, and measures taken and/or planned to be taken to the Division of Water Quality (DWQ), 288 North 1460 West, P.O. Box 144870, Salt Lake City, Utah 84114-4870. The Storm Water Pollution Prevention Plan must be modified within 14 calendar days of knowledge of the release to provide a description of the release, the circumstances leading to the release, and the date of the release. In addition, the plan must be reviewed to identify measures to prevent the reoccurrence of such releases and to respond to such releases, and the plan must be modified where appropriate.

Agency	Phone Number
National Response Center	(800) 424-8802
Division of Water Quality (DWQ) 24-Hr Reporting	(801)-231-1769 (801) 536-4123
Utah Department of Health Emergency Response	(801) 580-6681

Material	Media Released To	Reportable Quantity
Engine oil, fuel, hydraulic & brake fluid	Land	25 gallons
Paints, solvents, thinners	Land	100 lbs (13 gallons)
Engine oil, fuel, hydraulic & brake fluid	Water	Visible Sheen
Antifreeze, battery acid, gasoline, engine degreasers	Air, Land, Water	100 lbs (13 gallons)
Refrigerant	Air	1 lb

6.2 Pollution Prevention Controls

CGP Requirements	Example BMPs	EPA SWPPP Guide Section	BMPs Selected (Name and Reference Number if applicable)
Equipment and vehicle fueling (CGP 2.3.1)	Spill kits, SPCCP, drip pans, locate activities away from conveyances, use secondary containment	Chapter 5, P2 Principle 4	VEF – Vehicle and Equipment Fueling
Equipment and vehicle washing (CGP 2.3.2.)	Locating away from surface waters and storm water conveyances, directing wash waters to a sediment basin or sediment trap, using filtration devices	Chapter 5, P2 Principle 5	VEC – Vehicle and Equipment Cleaning
Storage, handling, and disposal of building products and waste (CGP 2.3.3.)	Cover (plastic sheeting / temporary roofs), secondary containment, leakproof containers, proper dumpsters, secured portable toilets, locate away from storm water conveyances	Chapter 5, P2 Principle 1 and 2	MS – Materials Storage PT – Portable Toilets
Washing of stucco, paint, concrete, form release oils, curing compounds, etc. (CGP 2.3.4.)	Leak proof containers, lined pits, locate away from storm water conveyances	Chapter 5, P2 Principle 3	MU – Material Use SCU – Spill Clean Up
Properly apply fertilizer (CGP 2.3.5)	Follow manufacture specifications, document deviations in applications, avoid applications to frozen ground, before heavy rains, or to storm water conveyances		MU – Material Use

BMP CBC: Catch Basin Cleaning

<i>Installation Schedule:</i>	Operator/Contractor to utilize during construction while under obligation of the NOI. Owner to utilize throughout the remainder of the life of the storm drain system.
<i>Maintenance and Inspection:</i>	Annual/monthly inspection of public and private facilities to ensure sediment that reaches more than 2 inches in depth is removed. This will help maintain functionality of these facilities.
<i>Responsible Staff:</i>	Provided by Contractor
<i>Design Specifications and Drawings:</i>	See corresponding BMP details in Appendix H

BMP CWM: Concrete Waste Management

<i>Installation Schedule:</i>	Install before concrete is used onsite.
<i>Maintenance and Inspection:</i>	Inspect subcontractors to ensure concrete wastes are being properly managed. Dispose of hardened concrete on a regular basis. Empty washout before volume exceeds 2/3 of capacity.
<i>Responsible Staff:</i>	Provided by Contractor
<i>Design Specifications and Drawings:</i>	See corresponding BMP details in Appendix H

BMP HWM: Hazardous Waste Management

<i>Installation Schedule:</i>	Utilize through project, especially during training, waste disposal, and material use.
<i>Maintenance and Inspection:</i>	Inspect hazardous waste receptacles and areas regularly. Arrange for regular hazardous waste collection.
<i>Responsible Staff:</i>	Provided by Contractor
<i>Design Specifications and Drawings:</i>	See corresponding BMP details in Appendix H

<i>BMP MU: Material Use</i>	
<i>Installation Schedule:</i>	Use throughout duration of construction and train personnel before construction materials are used on site.
<i>Maintenance and Inspection:</i>	Use throughout duration of construction and train personnel before construction materials are used on site. Minimize discharges of fertilizers containing nitrogen or phosphorous by selecting alternative, less hazardous materials as much as possible. Do not over apply fertilizers, herbicides, and pesticides. Prepare only amount needed.
<i>Responsible Staff:</i>	Provided by Contractor
<i>Design Specifications and Drawings:</i>	See corresponding BMP details in Appendix H
<i>BMP MS: Materials Storage</i>	
<i>Installation Schedule:</i>	Install before any construction materials are brought to the site.
<i>Maintenance and Inspection:</i>	Utilize throughout construction. Inspect areas daily and repair damage and correct incorrectly stored items.
<i>Responsible Staff:</i>	Provided by Contractor
<i>Design Specifications and Drawings:</i>	See corresponding BMP details in Appendix H
<i>BMP PC: Plastic Covering</i>	
<i>Installation Schedule:</i>	Utilize whenever stockpiles are present.
<i>Maintenance and Inspection:</i>	Inspect daily during construction during the workweek.
<i>Responsible Staff:</i>	Provided by Contractor
<i>Design Specifications and Drawings:</i>	See corresponding BMP details in Appendix H
<i>BMP PT: Portable Toilets</i>	
<i>Installation Schedule:</i>	Locate in convenient locations. Construct as required.
<i>Maintenance and Inspection:</i>	Utilize licensed service with daily observation for leak detection. Arrange for collection with licensed service.
<i>Responsible Staff:</i>	Provided by Contractor
<i>Design Specifications and Drawings:</i>	See corresponding BMP details in Appendix H

<i>BMP SP: Seeding and Planting</i>	
<i>Installation Schedule:</i>	Provided by Contractor
<i>Maintenance and Inspection:</i>	Adequate watering and fertilization shall be used. Grass shall be watered and mowed.
<i>Responsible Staff:</i>	Provided by Contractor
<i>Design Specifications and Drawings:</i>	See corresponding BMP details in Appendix H
<i>BMP SCU: Spill Clean-Up</i>	
<i>Installation Schedule:</i>	Immediately upon spills that may be harmful to receiving waters.
<i>Maintenance and Inspection:</i>	Clean up spills immediately and remediate cause. Document all spills with required data. Contact required authorities for any spill of reportable quantity.
<i>Responsible Staff:</i>	Provided by Contractor
<i>Design Specifications and Drawings:</i>	See corresponding BMP details in Appendix H
<i>BMP SDF: Storm Drain Flushing</i>	
<i>Installation Schedule:</i>	Use for any piping which has or develops a sediment deposit propensity. Utilize schedule that keeps pipes clear of excessive buildup.
<i>Maintenance and Inspection:</i>	When possible, flushed effluent should be collected, decanted, evaporated, and disposed of in a landfill.
<i>Responsible Staff:</i>	Provided by Contractor
<i>Design Specifications and Drawings:</i>	See corresponding BMP details in Appendix H
<i>BMP UOR: Used Oil Recycling</i>	
<i>Installation Schedule:</i>	Implement before any vehicle maintenance occurs on-site.
<i>Maintenance and Inspection:</i>	Contract with a firm specializing in recycling or disposing of this material if necessary. May also be taken to service stations, auto parts retail stores, or landfills.
<i>Responsible Staff:</i>	Provided by Contractor
<i>Design Specifications and Drawings:</i>	See corresponding BMP details in Appendix H

<i>BMP VEC: Vehicle and Equipment Cleaning</i>	
<i>Installation Schedule:</i>	Install Before any construction vehicles leave the site.
<i>Maintenance and Inspection:</i>	Requirements for this BMP are minimal. Some repair may be necessary.
<i>Responsible Staff:</i>	Provided by Contractor
<i>Design Specifications and Drawings:</i>	See corresponding BMP details in Appendix H
<i>BMP VEF: Vehicle and Equipment Fueling</i>	
<i>Installation Schedule:</i>	Install before fuel is brought to the site
<i>Maintenance and Inspection:</i>	Inspect tanks and fueling areas regularly and keep spill cleanup materials onsite.
<i>Responsible Staff:</i>	Provided by Contractor
<i>Design Specifications and Drawings:</i>	See corresponding BMP details in Appendix H
<i>BMP VEMR: Vehicle and Equipment Maintenance & Repair</i>	
<i>Installation Schedule:</i>	Utilize during any equipment or vehicle maintenance that occurs on-site.
<i>Maintenance and Inspection:</i>	Keep equipment clean, don't allow excessive build-up of oil and grease. Inspect equipment for leaks on a regular basis. Check incoming vehicles for leaking oil and fluids. Do not hose down areas, rather use dry sweeping.
<i>Responsible Staff:</i>	Provided by Contractor
<i>Design Specifications and Drawings:</i>	See corresponding BMP details in Appendix H
<i>BMP WHD: Waste Handling and Disposal</i>	
<i>Installation Schedule:</i>	Utilize at all times while construction waste is being generated onsite.
<i>Maintenance and Inspection:</i>	Inspect areas frequently for trash and debris. Ensure site dumpster is available and being used. Arrange for regular collection.
<i>Responsible Staff:</i>	Provided by Contractor
<i>Design Specifications and Drawings:</i>	See corresponding BMP details in Appendix H

SECTION 7: SPECIAL CONDITIONS

7.1 Emergency Related Projects

Emergency-Related Project? Yes No

7.2 UIC Class 5 Injection Wells

Check box if section not applicable to this site

Class V UIC Wells on site (all must be reported to DWQ for inventory):

- Infiltration trenches (if storm water is directed to any shaft or hole that is deeper than its widest surface dimension or has a subsurface fluid distribution system)
- Commercially manufactured pre-cast or pre-built subsurface detention vault/infiltration system
- Drywell, seepage pit, or improved sinkhole (if storm water is directed to any shaft or hole that is deeper than its widest surface dimension or has a subsurface fluid distribution system)

Description of your Class V Injection Well and any local requirements:

Description of any additional BMPs used in conjunction with the UIC well.

7.3 Chemical Treatment

Check box if section not applicable to this site

Soil Types

List all the soil types (including soil types expected to be found in fill material) that are expected to be exposed during construction and that will be discharged to locations where chemicals will be applied:

Treatment Chemicals

List all treatment chemicals that will be used at the site and explain why these chemicals are suited to the soil characteristics:

Describe the dosage of all treatment chemicals you will use at the site or the methodology you will use to determine dosage:

Provide information from any applicable Safety Data Sheets (SDS):

Describe how each of the chemicals will stored:

Include references to applicable state or local requirements affecting the use of treatment chemicals, and copies of applicable manufacturer's specifications regarding the use of your specific treatment chemicals and/or chemical treatment systems:

Special Controls for Cationic Treatment Chemicals (if applicable)

If you have been authorized by DWQ to use cationic treatment chemicals, identify the specific controls and implementation procedures you are required to implement to ensure that your use of cationic treatment chemicals will not lead to a violation of water quality standards or harm aquatic life:

Schematic Drawings of Storm Water Controls/Chemical Treatment Systems

Provide schematic drawings of any chemically-enhanced storm water controls or chemical treatment systems to be used for application of treatment chemicals:

Training

Describe the training that personnel who handle and apply chemicals have received prior to permit coverage, or will receive prior to the use of treatment chemicals:

SECTION 8: INSPECTIONS & CORRECTIVE ACTIONS

8.1 Inspections

Minimum Inspection Schedule Requirements:

Standard Frequency:
<input type="checkbox"/> Once every 7 calendar days.
<input type="checkbox"/> Once every 14 calendar days and within 24 hours of the end of a storm event of 0.5 inches or greater. Rain gauge/weather station used: Contractor to keep rain gauge onsite if this option is chosen.
Increased Frequency (if applicable):
<input type="checkbox"/> <i>Sites discharging to impaired or high-quality waters: Once every 7 calendar days and within 24 hours of the end of a storm event of 0.5 inches or greater.</i>
Decreased Frequency (if applicable):
<input type="checkbox"/> <i>Arid areas: once a month and within 24 hours of a 0.5-inch storm event or greater.</i>
<input type="checkbox"/> <i>Semi-arid areas: once a month and within 24 hours of a 0.5-inch storm event or greater during the dry season:</i>
<input type="checkbox"/> <i>Frozen conditions with work suspended – must have 3 months of continuous expected frozen conditions based on historical averages: no inspections</i>
<input type="checkbox"/> <i>Frozen conditions with continued activities - must have 3 months of continuous expected frozen conditions based on historical averages: once per month</i>
Other:
<input type="checkbox"/> Describe alternative frequency:

Inspection Reports are filed in Appendix C

8.2 Corrective Actions

Correction Action Report is filed in Appendix D.

8.3 Delegation of Authority

See the signed delegation of authority forms (if applicable in Appendix E.)

SECTION 10: CERTIFICATION

Owner

I certify under penalty of law that this document and all attachments were prepared under my direction or supervision in accordance with a system designed to assure that qualified personnel properly gathered and evaluated the information submitted. Based on my inquiry of the person or persons who manage the system, or those persons directly responsible for gathering the information, the information submitted is, to the best of my knowledge and belief, true, accurate, and complete. I am aware that there are significant penalties for submitting false information, including the possibility of fine and imprisonment for knowing violations.

Name:

Title:

Signature:

Date:

General Contractor

I certify under penalty of law that this document and all attachments were prepared under my direction or supervision in accordance with a system designed to assure that qualified personnel properly gathered and evaluated the information submitted. Based on my inquiry of the person or persons who manage the system, or those persons directly responsible for gathering the information, the information submitted is, to the best of my knowledge and belief, true, accurate, and complete. I am aware that there are significant penalties for submitting false information, including the possibility of fine and imprisonment for knowing violations.

Name:

Title:

Signature:

Date:

SWPPP APPENDICES

Attach the following documentation to the SWPPP:

Appendix A – Site Maps

Appendix B – NOI

Appendix C – Inspection Reports

Appendix D – Corrective Action Report

***Appendix E – Subcontractor
Certifications/Agreements/Delegation of
Authority (see CGP 9.16(1)b.)***

Appendix F – Training Logs and Certifications (see CGP 6)

***Appendix G – Additional Information (i.e., Other permits such as
dewatering, stream alteration, wetland; and out of
date swppp documents)***

Appendix H – BMP Instruction and Detail Specifications

Appendix I – Construction General Permit

Appendix A: Site Maps

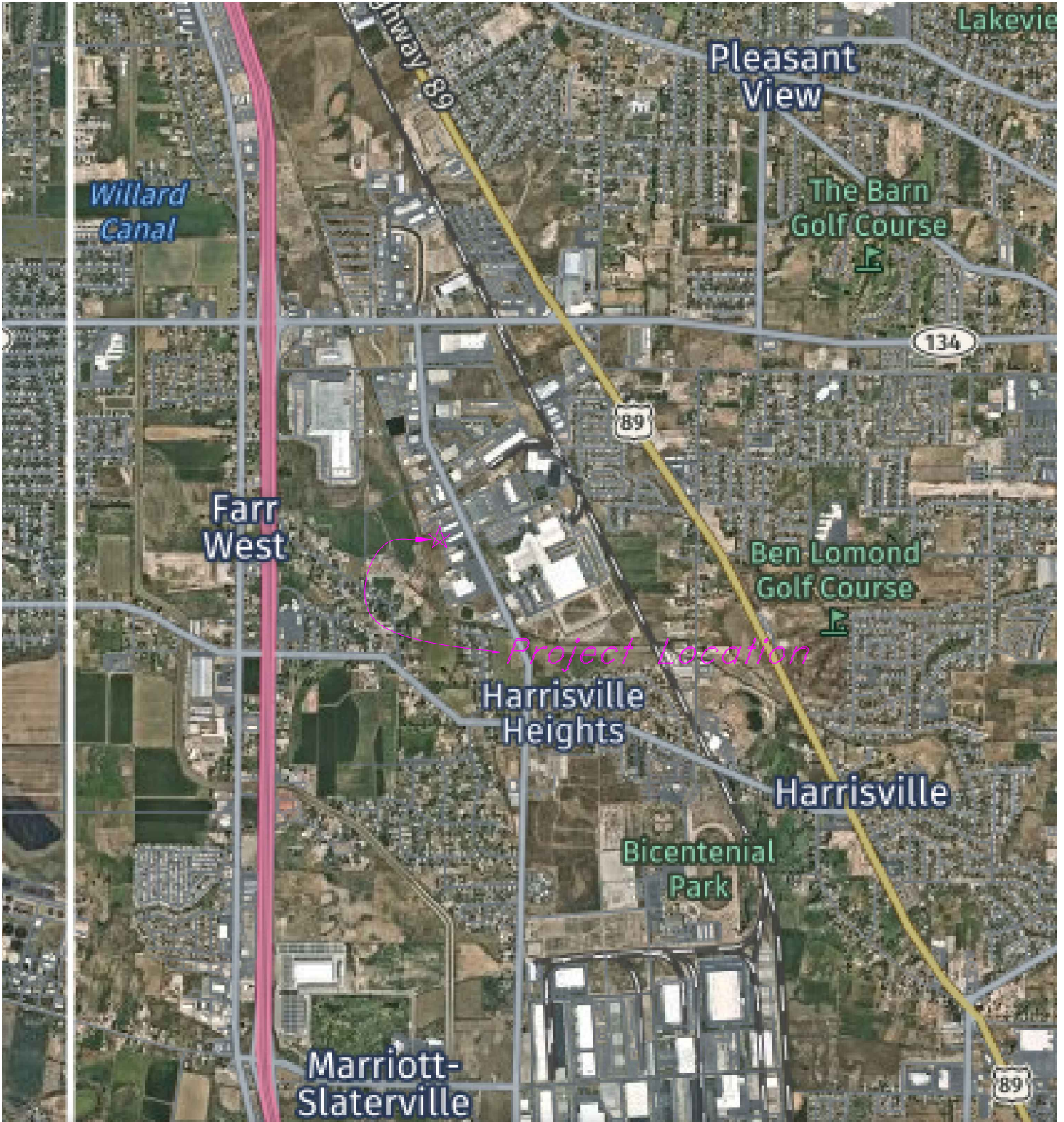

General Location Map

Scale: NTS



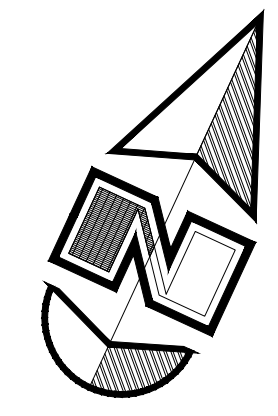
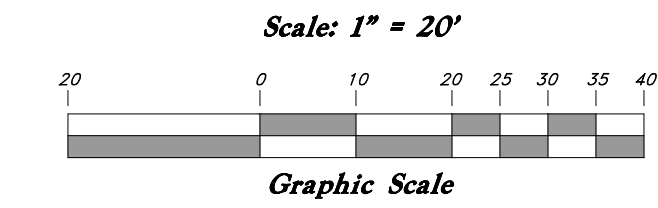

Legend

(Note: All items may not appear on drawing)

—E—	Centerline	TA	Top of Asphalt	C.M.P.	Corrugated Metal Pipe
-UGT-	Buried Telephone line	EA	Edge of Asphalt	R.C.P.	Reinforced Concrete Pipe
-OHT-	Overhead Telephone line	NG	Natural Ground	CONC	Edge of Concrete
-OHP-	Overhead Power line	LG	Lip of Gutter	RWALL	Retaining Wall
-UGP-	Power line	SP	Service Pole	SMH	Sewer Manhole
-S-	Sanitary Sewer line	LP	Light Pole	WV	Water Valve
-W-	Culinary Water line	PP	Power Pole	CB	Catch Basin
-G-	Gas line	TP	Telephone Pole	DC	Diversion Box
-SD-	Storm Drain line	FH	Fire Hydrant	TC	Top of Curb
-SW-	Secondary Waterline	DIT	Ditch	SW	Sidewalk
-LD-	Land Drain line	TOE	Toe of Slope	GUY	Gas line Marker
-IW-	Irrigation Waterline	TOP	Top of Slope	BLDG	Building Corner
-X-X-	Fence	CO	Cleanout	NG	Natural Ground
●	Power Pole	FC	Fence	GAS	Guy Wire
⊙	Post	DMH	Drain Manhole	□	Fire Hydrant
⊙	Water Meter	FL	Flowline	⊕	Water Valve
⊙	Gas Meter	x99.00	Spot Elevation	⊕	Light Pole
⊙	Telephone Box	Contour	Contour	⊕	Power Pole w/guy
⊙	Sewer Manhole	Asphalt	Asphalt	⊕	Deciduous Tree
⊙	Drain Manhole	Concrete	Concrete	⊕	Coniferous Tree
⊙	Water Manhole	Building	Building		
⊙	Cleanout Box	Catch Basin	Catch Basin		

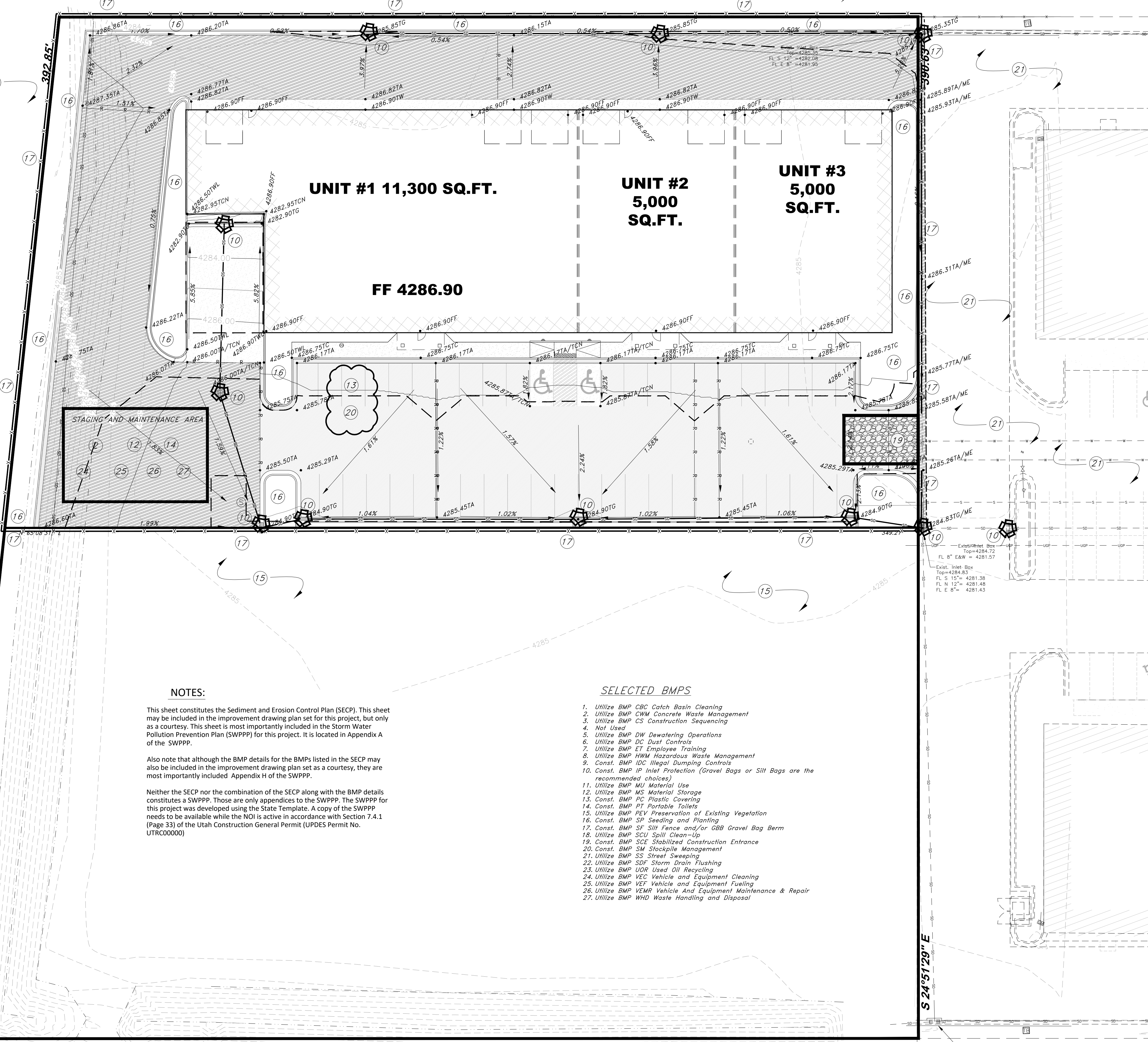

NOTES:

This sheet constitutes the Sediment and Erosion Control Plan (SECP). This sheet may be included in the improvement drawing plan set for this project, but only as a courtesy. This sheet is most importantly included in the Storm Water Pollution Prevention Plan (SWPPP) for this project. It is located in Appendix A of the SWPPP.

Also note that although the BMP details for the BMPs listed in the SECP may also be included in the improvement drawing plan set as a courtesy, they are most importantly included Appendix H of the SWPPP.

Neither the SECP nor the combination of the SECP along with the BMP details constitutes a SWPPP. Those are only appendices to the SWPPP. The SWPPP for this project was developed using the State Template. A copy of the SWPPP needs to be available while the NOI is active in accordance with Section 7.4.1 (Page 33) of the Utah Construction General Permit (UPDES Permit No. UTRC00000).

- SELECTED BMPs**
- Utilize BMP CBC Catch Basin Cleaning
 - Utilize BMP CWM Concrete Waste Management
 - Utilize BMP CS Construction Sequencing
 - Not Used
 - Utilize BMP DW Dewatering Operations
 - Utilize BMP DC Dust Controls
 - Utilize BMP ET Employee Training
 - Utilize BMP HWM Hazardous Waste Management
 - Const. BMP IDC Illegal Dumping Controls
 - Const. BMP IP Inlet Protection (Gravel Bags or Silt Bags are the recommended choices)
 - Utilize BMP MU Material Use
 - Utilize BMP MS Material Storage
 - Const. BMP PC Plastic Covering
 - Const. BMP PT Portable Toilets
 - Utilize BMP PEV Preservation of Existing Vegetation
 - Const. BMP SP Seeding and Planting
 - Const. BMP SF Silt Fence and/or GBB Gravel Bag Berm
 - Utilize BMP SOU Spill Clean-Up
 - Const. BMP SCE Stabilized Construction Entrance
 - Const. BMP SM Stockpile Management
 - Utilize BMP SS Street Sweeping
 - Utilize BMP SDF Storm Drain Flushing
 - Utilize BMP UOR Used Oil Recycling
 - Utilize BMP VEC Vehicle and Equipment Cleaning
 - Utilize BMP VEF Vehicle and Equipment Fueling
 - Utilize BMP VEMR Vehicle And Equipment Maintenance & Repair
 - Utilize BMP WHD Waste Handling and Disposal

GREAT BASIN ENGINEERING

5746 SOUTH 1475 EAST, OGDEN, UTAH 84403
 WWW.GREATBASINENGINEERING.COM

Sediment & Erosion Control Plan
Weber Industrial Park (Foxrun)
 2147 Rulon White Blvd
 Ogdan, Utah
 A part of Section 36, T7N, R2W, SL&M, U.S. Survey

Appendix B: NOI

Appendix C: Inspection Reports

Place all completed inspection reports in this appendix. You may also put blank inspection reports here to be completed.

You are encouraged to create your own inspection forms for each site. Inspection reports must have the following information:

- 1) The inspection date.
- 2) The UPDES ID number (UTRXXXXX).
- 3) Name and title of personnel making the inspections.
- 4) Summary of inspection findings and any necessary corrective actions:
 - a. Are storm water controls properly installed and operational? If failed then why?
 - b. Presence of any conditions that could lead to spills or leaks.
 - c. Locations where new or modified controls are necessary.
 - d. Signs of visible erosion or sediment depositing related to your discharges.
 - e. Any incidents of noncompliance.
 - f. Visual quality of any discharges occurring.
- 5) Rainfall amount if the inspection was triggered by a precipitation event.
- 6) If it was unsafe to inspect any areas of the site, a description of the area and reason.

Appendix D: Corrective Action Report

Appendix E: Subcontractor Certifications/Agreements/Delegation of Authority (CGP 9.16.(1)b.)

A sample subcontractor agreement form and delegation of authority form have been included in this appendix. If these are used, keep complete signed forms here.

SUBCONTRACTOR CERTIFICATION
STORM WATER POLLUTION PREVENTION PLAN

Project Number: _____

Project Title: _____

Operator(s): _____

As a subcontractor, you are required to comply with the Storm water Pollution Prevention Plan (SWPPP) for any work that you perform on-site. Any person or group who violates any condition of the SWPPP may be subject to substantial penalties or loss of contract. You are encouraged to advise each of your employees working on this project of the requirements of the SWPPP. A copy of the SWPPP is available for your review at request.

Each subcontractor engaged in activities at the construction site that could impact storm water must be identified and sign the following certification statement:

I certify under the penalty of law that I have read and understand the terms and conditions of the SWPPP for the above designated project and agree to follow the BMPs and practices described in the SWPPP.

This certification is hereby signed in reference to the above named project:

Company: _____

Address: _____

Telephone Number: _____

Type of construction service to be provided: _____

Signature: _____

Title: _____

Date: _____

Delegation of Authority

I, _____, hereby designate the person or specifically described position below to be a duly authorized representative for the purpose of overseeing compliance with environmental requirements, including the UPDES "General Permit for Storm Water Discharges Associated with Construction Activity" (CGP), at the construction site:

_____, Permit No. UTR _____

The designee is authorized to sign all reports required by the Permit and other information requested by the Director of the Utah Division of Water Quality, or by an authorized representative of the Executive Secretary.

Name of Person or Position: _____

Owner/Operator: _____

Mailing Address: _____

City, State, Zip Code: _____

Phone Number: _____

By signing this authorization, I confirm that I meet the requirements to make such a designation as set forth in Part G.16.1.2. of the CGP, and that the designee above meets the definition of a "duly authorized representative" as set forth in Part G.16.1.2 of the CGP.

I certify under penalty of law that this document and all attachments were prepared under my direction or supervision in accordance with a system designed to assure that qualified personnel properly gather and evaluate the information submitted. Based on my inquiry of the person or persons who manage the system, or those persons directly responsible for gathering the information, the information submitted is, to the best of my knowledge and belief, true, accurate, and complete. I am aware that there are significant penalties for submitting false information, including the possibility of fine and imprisonment for knowing violations.

Name: _____

Title: _____

Signature: _____

Date: _____

Appendix F: Training Logs and Certifications (see CGP 6)

A sample training log has been included in this appendix to keep track of trainings that have been provided. At a minimum, storm water team members that require training should be provided with the following if it relates to their duties (CGP Part 6.3.):

- The permit deadlines associated with installation, maintenance, and removal of storm water controls and with stabilization;
- The location of all storm water controls on the site required by this permit and how they are to be maintained;
- The proper procedures to follow with respect to the permit's pollution prevention requirements; and
- When and how to conduct inspections, record applicable findings, and take corrective actions

Certifications for SWPPP inspectors or writers can also be placed in this appendix.

SWPPP Training Log

Storm Water Pollution Prevention Training Log

Project Name: _____

Project Location: _____

Instructor's Name(s): _____

Instructor's Title(s): _____

Course Location: _____ Date: _____

Course Length (hours): _____

Storm Water Training Topic: *(check as appropriate)*

- Erosion Control BMPs
- Sediment Control BMPs
- Non-Storm Water BMPs
- Emergency Procedures
- Good Housekeeping BMPs

Specific Training Objective: _____

Attendee Roster: *(attach additional pages as necessary)*

No.	Name of Attendee	Company
1		
2		
3		
4		
5		
6		
7		
8		
9		
10		

Appendix G: Additional Information

Use this appendix for additional information such as other permits (dewatering, stream alteration, etc.) or out of date SWPPP documents.

Appendix H: BMP Instruction and Detail Specifications

Use this appendix if complete BMP specifications are not provided in Section 5 or 6 of the SWPPP.

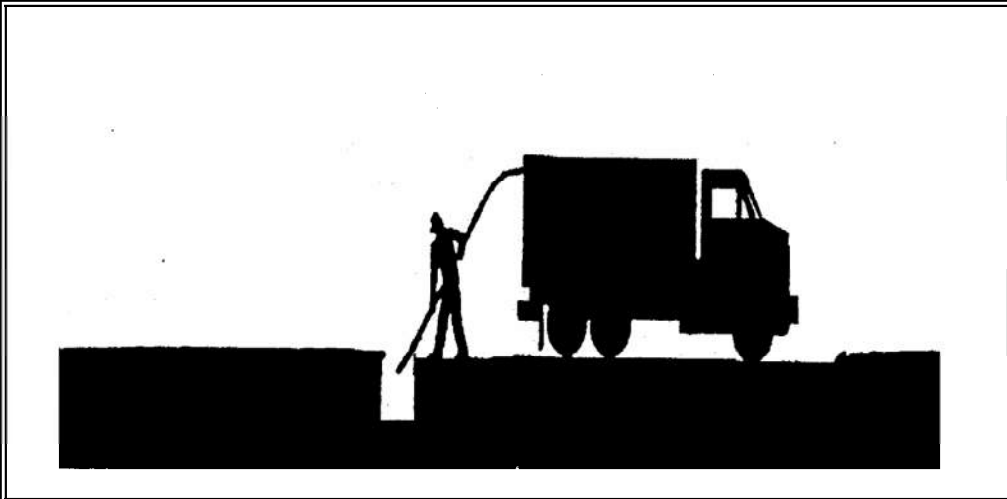

DESCRIPTION:

Maintain catch basin and stormwater inlets on a regular basis to remove pollutants, reduce high pollutant concentrations during the first flush of storms, prevent clogging of the downstream conveyance system, and restore the catch basins' sediment trapping capacity. A catch basin is distinguished from a stormwater inlet by having at its base a sediment sump designed to catch and retain sediments below the overflow point. This information sheet focuses on the cleaning of accumulated sediments from catch basins.

APPROACH:

Regular maintenance of catch basins and inlets is necessary to ensure their proper functioning. Clogged catch basins are not only useless but may act as a source of sediments and pollutants. In general, the key to effective catch basins are:

- ▶ At least annual inspections.
- ▶ Prioritize maintenance to clean catch basins and inlets in areas with the highest pollutant loading.
- ▶ Clean catch basins in high pollutant load areas just before the wet season to remove sediments and debris accumulated during the summer.
- ▶ Keep accurate logs of the number of catch basins cleaned.
- ▶ Record the amount of waste collected.

LIMITATIONS:

There are no major limitations to this best management practice.

MAINTENANCE:

Regular maintenance of public and private catch basins and inlets is necessary to ensure their proper functioning. Clogged catch basins are not only useless but may act as a source of sediments and pollutants. In general, the keys to effective catch basins are:

- ▶ Annual/monthly inspection of public and private facilities to ensure structural integrity, a clean sump, and a stenciling of catch basins and inlets.
- ▶ Keep logs of the number of catch basins cleaned.
- ▶ Record the amount of waste collected.

PROGRAM ELEMENTS

- New Development
- Residential
- Commercial Activities
- Industrial Activities
- Municipal Facilities
- Illegal Discharges

TARGETED POLLUTANTS

- Sediment
- Nutrients
- Heavy Metals
- Toxic Materials
- Oxygen Demanding Substances
- Oil & Grease
- Floatable Materials
- Bacteria & Viruses

- High Impact
- Medium Impact
- Low or Unknown Impact

IMPLEMENTATION REQUIREMENTS

- Capital Costs
- O&M Costs
- Regulatory
- Training
- Staffing
- Administrative

- High
- Medium
- Low

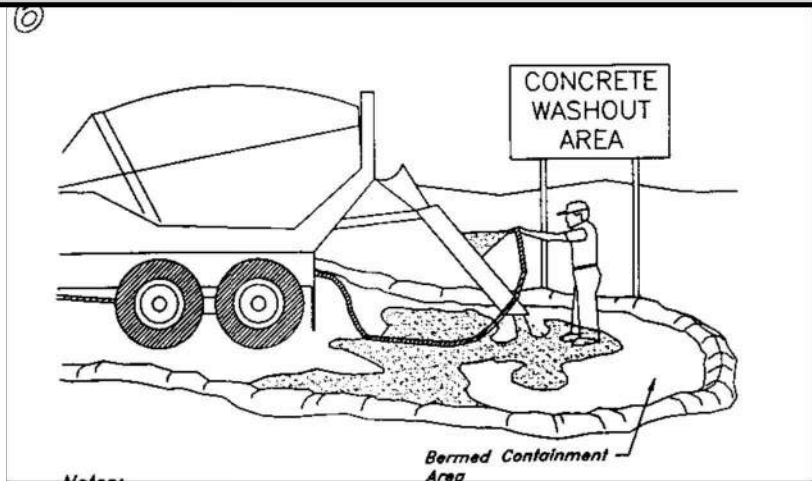

OBJECTIVES

- Housekeeping Practices
- Contain Waste
- Minimize Disturbed Areas
- Stabilize Disturbed Areas
- Protect Slopes/Channels
- Control Site Perimeter
- Control Internal Erosion

TARGETED POLLUTANTS

- H M L**
- Sediment
 - Nutrients
 - Heavy Metals
 - Toxic Materials
 - Oil & Grease
 - Floatable Materials
 - Bacteria & Viruses
 - Other Waste

IMPLEMENTATION REQUIREMENTS

- H M L**
- Capital Costs
 - O&M Costs
 - Maintenance
 - Training
 - Staffing
 - Administrative

H = High M = Medium L = Low

Handwritten signature

Handwritten signature

DESCRIPTION:

Prevent or reduce the discharge of pollutants to storm water from concrete waste by conducting washout off-site, performing on-site washout in a designated area, and training employees and subcontractors.

APPLICATION:

This technique is applicable to all types of sites

INSTALLATION / APPLICATION CRITERIA:

- Store dry materials under cover, away from drainage areas
- Minimize excess mixing of fresh concrete, mortar or cement on site
- Do not wash out concrete trucks into storm drains, open ditches, streets, or streams
- Do not allow excess concrete to be dumped on-site, except in designated areas
- When washing concrete to remove fine particles and expose the aggregate, avoid creating runoff by draining the water within a bermed or level area (6" tall X 6' wide)
- Train employees and subcontractors in proper concrete waste management

LIMITATIONS:

- Off-site washout or concrete wastes may not always be possible

MAINTENANCE:

- Inspect subcontractors to ensure that concrete wastes are being properly managed
- If using a temporary pit, dispose of hardened concrete on a regular basis



In sequenced construction, sites are completed in stages and completed portions are permanently stabilized before other areas are disturbed

DESCRIPTION:

Construction sequencing requires creating and following a work schedule that balances the timing of land disturbance activities and the installation of measures to control erosion and sedimentation, in order to reduce on-site erosion and off-site sedimentation. Staging areas can be used to limit contamination and erosion.

APPROACH:

Construction sequencing can be used to plan earthwork and erosion and sediment control (ESC) activities at sites where land disturbances might affect water quality in a receiving water body.

Construction sequencing schedules should, at a minimum, include the following:

- The ESC practices that are to be installed
- Principal development activities
- Which measures should be installed before other activities are started
- Compatibility with the general contract construction schedule

The following activities and features should be included (as they apply):

- Construction access—entrance to site, construction routes, areas designated for equipment parking
- Sediment traps and barriers—basin traps, sediment fences, outlet protection
- Runoff conveyance system—stabilize stream banks, storm drains, channels, inlet and outlet protection, slope drains
- Land clearing and grading—site preparation (cutting, filling, and grading, sediment traps, barriers, diversions, drains, surface roughening)
- Landscaping and final stabilization—top-soiling, trees and shrubs, permanent seeding, mulching, sodding, riprap

LIMITATIONS:

- Weather and other unpredictable variables may affect construction sequence schedules.

MAINTENANCE:

- The construction sequence should be followed throughout the project and the written plan should be modified before any changes in construction activities are executed.

APPLICATIONS

- Manufacturing
- Material Handling
- Vehicle Maintenance
- Construction
- Commercial Activities
- Roadways
- Waste Containment
- Housekeeping Practices

TARGETED POLLUTANTS

- Sediment
- Nutrients
- Heavy Metals
- Toxic Materials
- Oxygen Demanding Substances
- Oil & Grease
- Floatable Materials
- Bacteria & Viruses

- High Impact
- Medium Impact
- Low or Unknown Impact

IMPLEMENTATION REQUIREMENTS

- Capital Costs
- O&M Costs
- Maintenance
- Training

- High
- Medium
- Low

Dewatering Operations (DW)

Description

The BMPs selected for construction dewatering vary depending on site-specific features such as soils, topography, anticipated discharge quantities, and discharge location. Dewatering typically involves pumping water from an inundated area to a BMP, and then downstream to a receiving waterway, sediment basin, or well-vegetated area. Dewatering typically involves use of several BMPs in sequence.



Photograph DW-1. A relatively small dewatering operation using straw bales and a dewatering bag.

Appropriate Uses

Dewatering operations are used when an area of the construction site needs to be dewatered as the result of a large storm event, groundwater, or existing ponding conditions. This can occur during deep excavation, utility trenching, and wetland or pond excavation.

Design and Installation

Dewatering techniques will vary depending on site conditions. However, all dewatering discharges must be treated to remove sediment before discharging from the construction site. Discharging water into a sediment trap or basin is an acceptable treatment option. Water may also be treated using a dewatering filter bag, and a series of straw bales or sediment logs. If these previous options are not feasible due to space or the ability to passively treat the discharge to remove sediment, then a settling tank or an active treatment system may need to be utilized. Settling tanks are manufactured tanks with a series of baffles to promote settling. Flocculants can also be added to the tank to induce more rapid settling. This is an approach sometimes used on highly urbanized construction sites. Contact the state agency for special requirements prior to using flocculents and land application techniques.



Photograph DW-2. Dewatering bags used for a relatively large dewatering operation.

Some commonly used methods to handle the pumped water without surface discharge include land application to vegetated areas through a perforated discharge hose (i.e., the "sprinkler method") or dispersal from a water truck for dust control.

Dewatering Operations	
Functions	
Erosion Control	Moderate
Sediment Control	Yes
Site/Material Management	Yes

Dewatering Operations (DW)

Dewatering discharges to non-paved areas must minimize the potential for scour at the discharge point either using a velocity dissipation device or dewatering filter bag.

Design Details are provided for these types of dewatering situations:

DW-1. Dewatering for Pond Already Filled with Water

DW-2 Dewatering Sump for Submersed Pump

DW-3 Sump Discharge Settling Basin

DW-4 Dewatering Filter Bag

Maintenance and Removal

When a sediment basin or trap is used to enable settling of sediment from construction dewatering discharges, inspect the basin for sediment accumulation. Remove sediment prior to the basin or trap reaching half full. Inspect treatment facilities prior to any dewatering activity. If using a sediment control practice such as a sediment trap or basin, complete all maintenance requirements as described in the fact sheets prior to dewatering.

Properly dispose of used dewatering bags, as well as sediment removed from the dewatering BMPs. Depending on the size of the dewatering operation, it may also be necessary to revegetate or otherwise stabilize the area where the dewatering operation was occurring.

Dewatering Operations (DW)

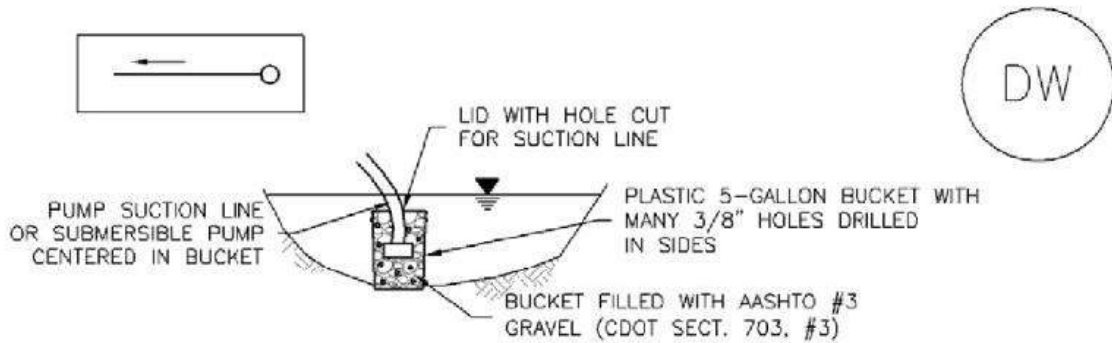

DW-1. DEWATERING POND ALREADY FILLED WITH WATER

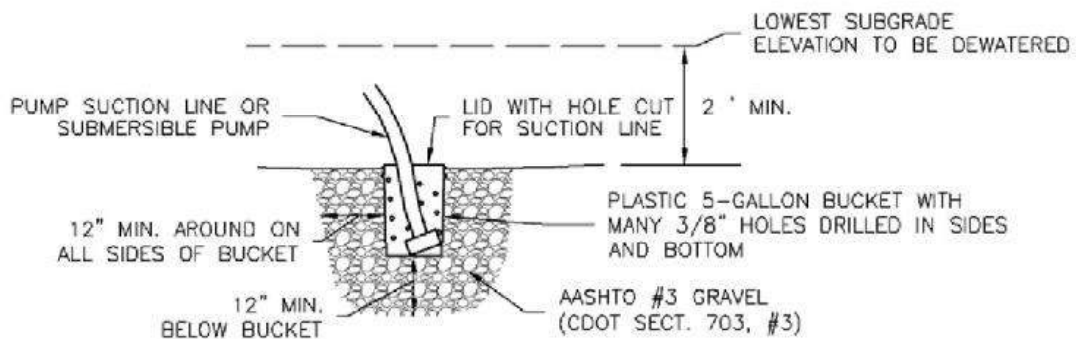

DW-2. DEWATERING SUMP FOR SUBMERSED PUMP

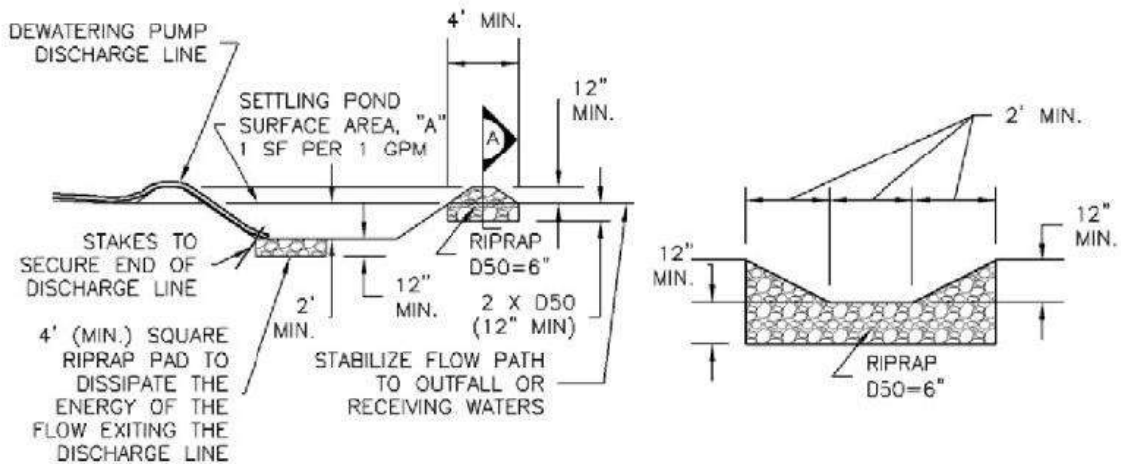

DW-3. SUMP DISCHARGE
SETTLING BASIN

SETTLING BASIN
SECTION A

Dewatering Operations (DW)

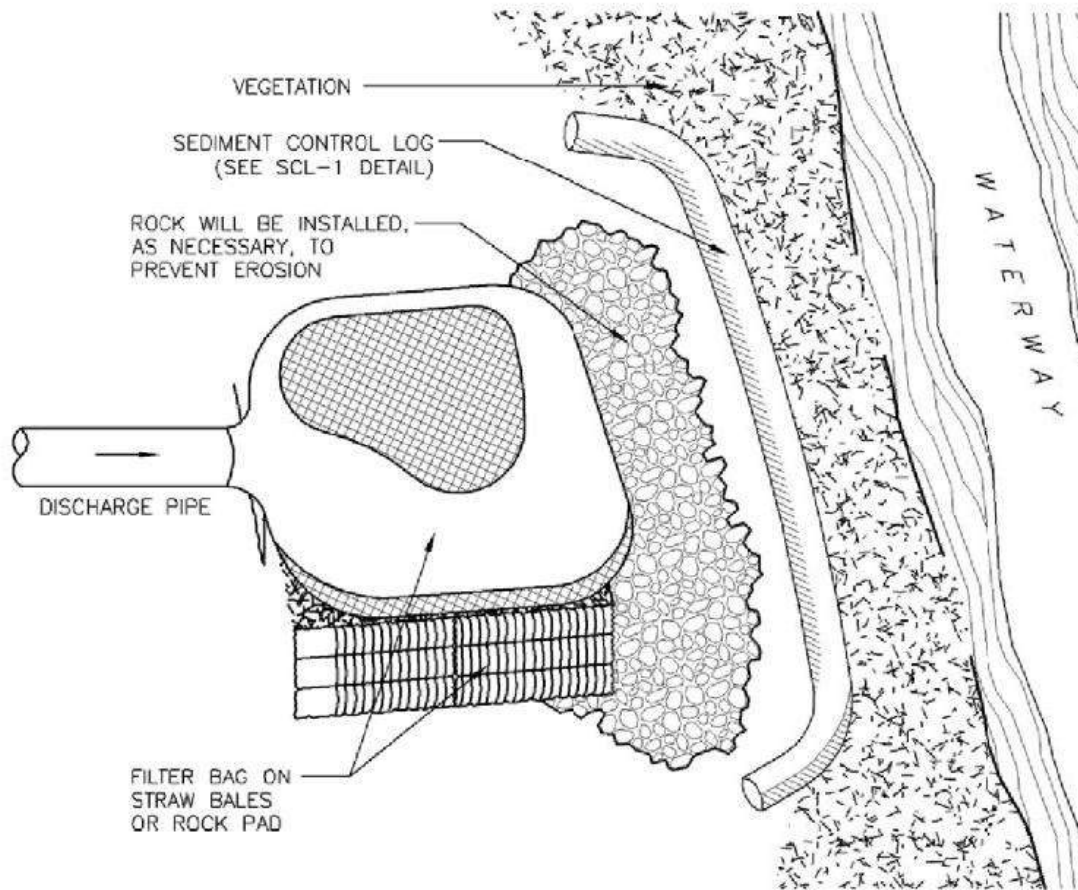

DW-4. DEWATERING FILTER BAG

DEWATERING INSTALLATION NOTES

1. SEE PLAN VIEW FOR:
 - LOCATION OF DEWATERING EQUIPMENT.
 - TYPE OF DEWATERING OPERATION (DW-1 TO DW-4).
2. THE OWNER OR CONTRACTOR SHALL OBTAIN A CONSTRUCTION DISCHARGE (DEWATERING) PERMIT FROM THE STATE PRIOR TO ANY DEWATERING OPERATIONS DISCHARGING FROM THE SITE. ALL DEWATERING SHALL BE IN ACCORDANCE WITH THE REQUIREMENTS OF THE PERMIT.
3. THE OWNER OR OPERATOR SHALL PROVIDE, OPERATE, AND MAINTAIN DEWATERING SYSTEMS OF SUFFICIENT SIZE AND CAPACITY TO PERMIT EXCAVATION AND SUBSEQUENT CONSTRUCTION IN DRY CONDITIONS AND TO LOWER AND MAINTAIN THE GROUNDWATER LEVEL A MINIMUM OF 2- FEET BELOW THE LOWEST POINT OF EXCAVATION AND CONTINUOUSLY MAINTAIN EXCAVATIONS FREE OF WATER UNTIL BACK-FILLED TO FINAL GRADE.

Dewatering Operations (DW)

DEWATERING INSTALLATION NOTES

4. DEWATERING OPERATIONS SHALL USE ONE OR MORE OF THE DEWATERING SUMPS SHOWN ABOVE, WELL POINTS, OR OTHER MEANS APPROVED BY THE LOCAL JURISDICTION TO REDUCE THE PUMPING OF SEDIMENT, AND SHALL PROVIDE A TEMPORARY SEDIMENT BASIN OR FILTRATION BMP TO REDUCE SEDIMENT TO ALLOWABLE LEVELS PRIOR TO RELEASE OFF SITE OR TO A RECEIVING WATER. A SEDIMENT BASIN MAY BE USED IN LIEU OF SUMP DISCHARGE SETTLING BASIN SHOWN ABOVE IF A 4-FOOT-SQUARE RIPRAP PAD IS PLACED AT THE DISCHARGE POINT AND THE DISCHARGE END OF THE LINE IS STAKED IN PLACE TO PREVENT MOVEMENT OF THE LINE.

DEWATERING MAINTENANCE NOTES

1. INSPECT BMPs EACH WORKDAY, AND MAINTAIN THEM IN EFFECTIVE OPERATING CONDITION. MAINTENANCE OF BMPs SHOULD BE PROACTIVE, NOT REACTIVE. INSPECT BMPs AS SOON AS POSSIBLE (AND ALWAYS WITHIN 24 HOURS) FOLLOWING A STORM THAT CAUSES SURFACE EROSION, AND PERFORM NECESSARY MAINTENANCE.

2. FREQUENT OBSERVATIONS AND MAINTENANCE ARE NECESSARY TO MAINTAIN BMPs IN EFFECTIVE OPERATING CONDITION. INSPECTIONS AND CORRECTIVE MEASURES SHOULD BE DOCUMENTED THOROUGHLY.

3. WHERE BMPs HAVE FAILED, REPAIR OR REPLACEMENT SHOULD BE INITIATED UPON DISCOVERY OF THE FAILURE.

4. DEWATERING BMPs ARE REQUIRED IN ADDITION TO ALL OTHER PERMIT REQUIREMENTS.

5. TEMPORARY SETTLING BASINS SHALL BE REMOVED WHEN NO LONGER NEEDED FOR DEWATERING OPERATIONS. ANY DISTURBED AREA SHALL BE COVERED WITH TOPSOIL, SEEDED AND MULCHED OR OTHERWISE STABILIZED IN A MANNER APPROVED BY THE LOCAL JURISDICTION.

NOTE: MANY JURISDICTIONS HAVE BMP DETAILS THAT VARY FROM UDFCD STANDARD DETAILS. CONSULT WITH LOCAL JURISDICTIONS AS TO WHICH DETAIL SHOULD BE USED WHEN DIFFERENCES ARE NOTED.

(DETAILS ADAPTED FROM DOUGLAS COUNTY, COLORADO, NOT AVAILABLE IN AUTOCAD)

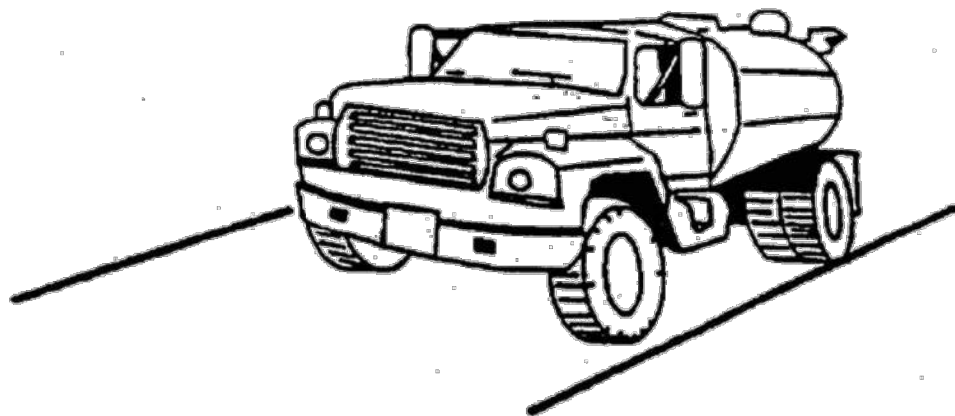

DESCRIPTION:

Dust control measures are used to stabilize soil from wind erosion, and reduce dust by construction activities.

APPLICATION:

Dust control is useful in any process area, loading and unloading area, material handling areas, and transfer areas where dust is generated. Street sweepers are limited to areas that are paved.

INSTALLATION / APPLICATION CRITERIA:

- Mechanical dust collection systems are designed according to the size of dust particles and the amount of air to be processed. Manufacturers' recommendations should be followed for installation (as well as the design of the equipment).
- Two kinds of street sweepers are common: brush and vacuum. Vacuum sweepers are more efficient and work best when the area is dry.
- Mechanical equipment should be operated according to the manufacturers' recommendations and should be inspected regularly.

LIMITATIONS:

- More elaborate equipment may be impossible to maintain by plant personnel
- Is labor and equipment intensive and may not be effective for all pollutants (street sweepers)

MAINTENANCE:

If water sprayers are used, dust-contaminated waters should be collected and taken for treatment. Areas will probably need to be resprayed to keep dust from spreading.

OBJECTIVES

- Housekeeping Practices
- Contain Waste
- Minimize Disturbed Areas
- Stabilize Disturbed Areas
- Protect Slopes/Channels
- Control Site Perimeter
- Control Internal Erosion

TARGETED POLLUTANTS

H M L

- Sediment
- Nutrients
- Heavy Metals
- Toxic Materials
- Oil & Grease
- Floatable Materials
- Bacteria & Viruses
- Other Waste

IMPLEMENTATION REQUIREMENTS

H M L

- Capital Costs
- O&M Costs
- Maintenance
- Training
- Staffing
- Administrative

H = High M = Medium L = Low

Handwritten signature

Handwritten signature

**DESCRIPTION:**

Employee training, like equipment maintenance, is a method by which to implement BMPs. Employee training should be used in conjunction with all other BMPs as part of the facility's SWPPP.

The specific employee training aspects of each of the source controls are highlighted in the individual information sheets. The focus of this information sheet is more general, and includes the overall objectives and approach for assuring employee training in stormwater pollution prevention. Accordingly, the organization of this information sheet differs somewhat from the other information sheets in this chapter.

OBJECTIVES:

Employee training should be based on four objectives:

- ◆ Promote a clear identification and understanding of the problem, including activities with the potential to pollute stormwater;
- ◆ Identify solutions (BMPs);
- ◆ Promote employee ownership of the problems and the solutions; and
- ◆ Integrate employee feedback into training and BMP implementation.

APPROACH:

- ◆ Integrate training regarding stormwater quality management with existing training programs that may be required for your business by other regulations.
- ◆ Businesses that are not regulated in Federal, State, or local regulations, may use the information in this handbook to develop a training program to reduce their potential to pollute stormwater.
- ◆ Employee training is a vital component of many of the individual source control BMPs included in this manual.



PROGRAM ELEMENTS

- New Development
- Residential
- Commercial Activities
- Industrial Activities
- Municipal Facilities
- Illegal Discharges

DESCRIPTION:

Prevent or reduce the discharge of pollutants to storm water from hazardous waste through proper material use, waste disposal, and training of employees. Another important aspect of this BMP is to insure the use of sub-consultants who are properly licensed and trained.

APPLICATION:

Many of the chemicals used on-site can be hazardous materials which become hazardous waste upon disposal. These wastes may include:

- ▶ Paints and solvents; petroleum products such as oils; fuels and greases; herbicides and pesticides; acids for cleaning masonry; and concrete curing compounds.

In addition, sites with existing structures may contain wastes which must be disposed of in accordance with federal, state and local regulations, including:

- ▶ Sandblasting grit mixed with lead, cadmium or chromium based paints, asbestos, and PCBs.

INSTALLATION/APPLICATION CRITERIA:

The following steps will help reduce storm water pollution from hazardous wastes:

- ▶ Use all of the product before disposing of the container.
- ▶ Do not remove the original product label, it contains important safety and disposal information.
- ▶ Do not over-apply herbicides and pesticides. Prepare only the amount needed. Follow the recommended usage instructions. Over-application is expensive and environmentally harmful. Apply surface dressings in several smaller applications, as opposed to one large application, to allow time for infiltration and to avoid excess material being carried off-site by runoff. Do not apply these chemicals just before it rains. People applying pesticides must be certified in accordance with federal and state regulations.

LIMITATIONS:

Hazardous waste that cannot be reused or recycled must be disposed of by a licensed hazardous waste collector.

MAINTENANCE:

- ▶ Inspect hazardous waste receptacles and areas regularly.
- ▶ Arrange for regular hazardous waste collection.

TARGETED POLLUTANTS

- Sediment
- Nutrients
- Heavy Metals
- Toxic Materials
- Oxygen Demanding Substances
- Oil & Grease
- Floatable Materials
- Bacteria & Viruses

- High Impact
- Medium Impact
- Low or Unknown Impact

IMPLEMENTATION REQUIREMENTS

- Capital Costs
- O&M Costs
- Regulatory
- Training
- Staffing
- Administrative

- High
- Medium
- Low



PROGRAM ELEMENTS

- New Development
- Residential
- Commercial Activities
- Industrial Activities
- Municipal Facilities
- Illegal Discharges

DESCRIPTION:

Implement measures to detect, correct, and enforce against illegal dumping of pollutants on streets, into the storm drain system, and into creeks. Substances illegally dumped on streets, into the storm drain system, and into creeks includes paints, used oil and other automotive fluids, construction debris, chemicals, fresh concrete, leaves, grass clippings, and pet wastes. All of these wastes can cause storm water and receiving water quality problems as well as clog the storm drain system.

APPROACH:

One of the keys to success is increasing the general public's awareness of the problem and to at least identify the incident, if not correct it. There are a number of ways of accomplishing this:

- ▶ Train municipal staff from all departments to recognize and report incidents.
- ▶ Deputize municipal staff who may come into contact with illegal dumping with the authority to write illegal dumping tickets for offenders caught in the act.
- ▶ Educate the public.
- ▶ Provide the public with a mechanism for reporting such as a hot line.

Establish system for tracking incidents which will identify:

- ▶ Illegal dumping "hot spots",
- ▶ Types and quantities (in some cases) of wastes,
- ▶ Patterns in time of occurrence (time of day/night, month, or year),
- ▶ Mode of dumping (abandoned containers, "midnight dumping" from moving vehicles, direct dumping of materials, accident/spills), and
- ▶ Responsible parties.

A tracking system also helps manage the program by indicating trends, and identifying who, what, when, and where efforts should be concentrated.

LIMITATIONS

The elimination of illegal dumping is dependent on the availability, convenience, and cost of alternative means of disposal.

TARGETED POLLUTANTS

- Sediment
- Nutrients
- Heavy Metals
- Toxic Materials
- Oxygen Demanding Substances
- Oil & Grease
- Floatable Materials
- Bacteria & Viruses

- High Impact
- Medium Impact
- Low or Unknown Impact

IMPLEMENTATION REQUIREMENTS

- Capital Costs
- O&M Costs
- Regulatory
- Training
- Staffing
- Administrative

- High Medium Low

BMP: Inlet Protection - Gravel Bags

IP-GB

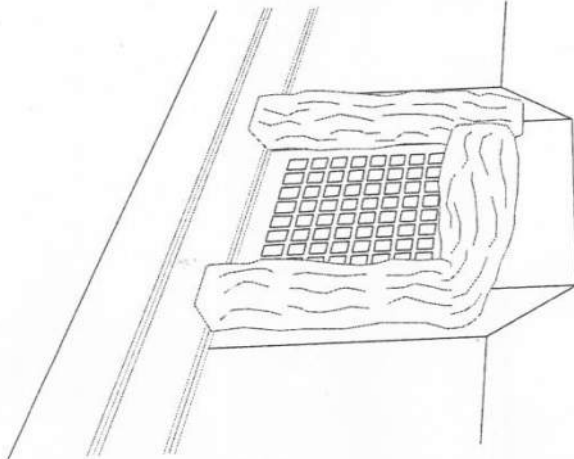

OBJECTIVES

- Housekeeping Practices
- Contain Waste
- Minimize Disturbed Areas
- Stabilize Disturbed Areas
- Protect Slopes/Channels
- Control Site Perimeter
- Control Internal Erosion

TARGETED POLLUTANTS

H M L

- Sediment
- Nutrients
- Heavy Metals
- Toxic Materials
- Oil & Grease
- Floatable Materials
- Bacteria & Viruses
- Other Waste

IMPLEMENTATION REQUIREMENTS

H M L

- Capital Costs
- O&M Costs
- Maintenance
- Training
- Staffing
- Administrative

H = High M = Medium L = Low

DESCRIPTION:

Sediment barrier erected around storm drain inlet.

APPLICATION:

Construct at storm drainage inlets located down-gradient of areas to be disturbed by construction

INSTALLATION / APPLICATION CRITERIA:

- Provide up-gradient sediment controls, such as silt fence during construction of inlet
- When construction of curb and gutter and roadway is complete, install gravel filled bags around perimeter of inlet
- Fill to recommended levels to reduce splitting of bags

LIMITATIONS:

- Recommended maximum contributing drainage area of one acre
- Requires shallow sloped adjacent to inlet.

MAINTENANCE:

- Inspect inlet protection following storm event and at a minimum of once every 14 days.
- Remove accumulated sediment when it reaches half the height of the bag.
- Look for bypassing or undercutting and repair or realign as needed.
- Replace and clean up spilled gravel when bags split.

BMP: Inlet Protection- Silt Bags

IP-SB

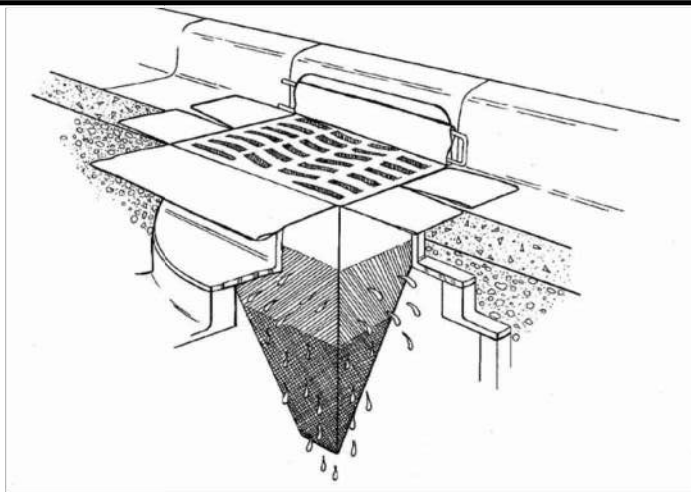

DESCRIPTION:

Collect and trap sediment and debris entering catch basins from either grated or curb inlets. Insert is made of fabric and is placed in the drain inlet around the perimeter of the grate. Runoff passes through the bag before discharging into the drain outlet pipe. Overflow holes are usually provided to pass larger flows without causing a backwater at the grate. Certain manufactured products include polymers intended to increase pollutant removal effectiveness.

APPLICATIONS:

- Storm drain inlet boxes

INSTALLATION / APPLICATION CRITERIA:

- Regular Maintenance is necessary
- Evaluation of the device chosen should be balanced with cost
- Hydraulic capacity controls effectiveness
- Most useful in small drainage areas (< 1 Acre)
- Ideal in combination with other BMP's

LIMITATIONS:

- Cost
- Maintenance required to prevent plugging and remain effective

MAINTENANCE:

Inspection after all storm events and as required between events

OBJECTIVES

- Housekeeping Practices
- Contain Waste
- Minimize Disturbed Areas
- Stabilize Disturbed Areas
- Protect Slopes/Channels
- Control Site Perimeter
- Control Internal Erosion

TARGETED POLLUTANTS

H M L

- Sediment
- Nutrients
- Heavy Metals
- Toxic Materials
- Oil & Grease
- Floatable Materials
- Bacteria & Viruses
- Other Waste

IMPLEMENTATION REQUIREMENTS

H M L

- Capital Costs
- O&M Costs
- Maintenance
- Training
- Staffing
- Administrative

H = High M = Medium L = Low

3/10

3/10

**DESCRIPTION:**

Prevent or reduce the discharge of pollutants to storm water from material use by using alternative products, minimizing hazardous material use on-site, and training employees and subcontractors.

APPLICATION:

The following materials are commonly used on construction sites:

- ◆ Pesticides and herbicides, fertilizers, detergents, plaster and other products, petroleum products such as fuel, oil, and grease.
- ◆ Other hazardous chemicals such as acids, lime, glues, paints, solvents, and curing compounds.

INSTALLATION/APPLICATION CRITERIA:

- ◆ Use less hazardous, alternative materials as much as possible.
- ◆ Minimize use of hazardous materials on-site.
- ◆ Use only materials where and when needed to complete the construction activity.
- ◆ Follow manufacturer's instructions regarding uses, protective equipment, ventilation, flammability, and mixing of chemicals.
- ◆ Personnel who use pesticides should be trained in their use.
- ◆ Do not over apply fertilizers, herbicides, and pesticides. Prepare only the amount needed.
- ◆ Unless on steep slopes, till fertilizers in to the soil rather than hydroseeding.
- ◆ Do not apply these chemicals just before it rains.

LIMITATIONS:

Alternative materials may not be available, suitable, or effective in every case.

MAINTENANCE:

Maintenance of this best management practice is minimal.

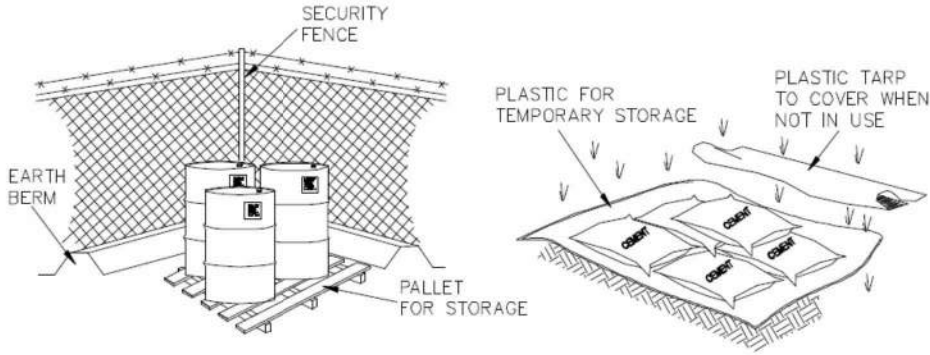

- CONTROLLED STORAGE LOCATION
- BARRIER AROUND PERIMETER
- ELEVATE CONTAINERS OFF GROUND
- COVER WHEN NOT IN USE

OBJECTIVES

- Housekeeping Practices
- Contain Waste
- Minimize Disturbed Areas
- Stabilize Disturbed Areas
- Protect Slopes/Channels
- Control Site Perimeter
- Control Internal Erosion

TARGETED POLLUTANTS

H M L

- Sediment
- Nutrients
- Heavy Metals
- Toxic Materials
- Oil & Grease
- Floatable Materials
- Bacteria & Viruses
- Other Waste

DESCRIPTION:

Controlled storage of on-site materials.

APPLICATION:

- Storage of hazardous, toxic, and all chemical substances
- Any construction site with outside storage of materials

INSTALLATION / APPLICATION CRITERIA:

- Designate a secured area with limited access as the storage location. Ensure no waterways or drainage paths are nearby
- Construct compacted earthen berm (See Earth Berm Barrier Information Sheet), or similar perimeter containment around storage location for impoundment in the case of spills
- Ensure all on-site personnel utilize designated storage area. Do not store excessive amounts of material that will not be utilized on site
- For active use of materials away from the storage area ensure materials are not set directly on the ground and are covered when not in use. Protect storm drainage during use

LIMITATIONS:

- Does not prevent contamination due to mishandling of products
- Spill Prevention and Response Plan still required
- Only effective if materials are actively stored in controlled location

MAINTENANCE:

- Inspect daily and repair any damage to perimeter impoundment or security fencing
- Check materials are being correctly stored (i.e. standing upright, in labeled containers, tightly capped) and that no materials are being stored away from the designated location

IMPLEMENTATION REQUIREMENTS

H M L

- Capital Costs
- O&M Costs
- Maintenance
- Training
- Staffing
- Administrative

H = High M = Medium L = Low

300

300

BMP PC

PLASTIC COVERING

DESCRIPTION

Plastic covering is used to cover exposed areas, which need immediate protection from erosion.

PURPOSE

The purpose of this BMP includes, but is not limited to:

- Providing immediate temporary erosion protection to slopes, piles and disturbed areas that cannot be covered by mulching.
- Protecting exposed surfaces from water and/or wind erosion.
- Used in winter months as a temporary erosive control device when grass seed will not germinate.

APPLICATIONS

This BMP may be used in disturbed areas, which require immediate erosion protection, areas seeded during winter and spring to aid in germination and for protection from heavy rain. Plastic covering may be used on steep slopes, construction sites and on stockpiles and/or excess materials. It may be used in combination with other BMPs.

LIMITATIONS

This BMP should not be used:

- For long term erosion control.
- Without controlling surface water runoff from the plastic covered area.

CONSTRUCTION GUIDELINES

- Plastic must be secured by staking or using weight (i.e. sandbag or tires) to prevent movement. Rebar must not be used as a staking mechanism.
- Plastic covering must be "keyed" in at the top of the slope.
- Additional BMPs, such as a berm and/or sediment control, must be used to control surface water runoff from plastic.

BMP MAINTENANCE

- During construction, inspect BMPs daily during the workweek.
-

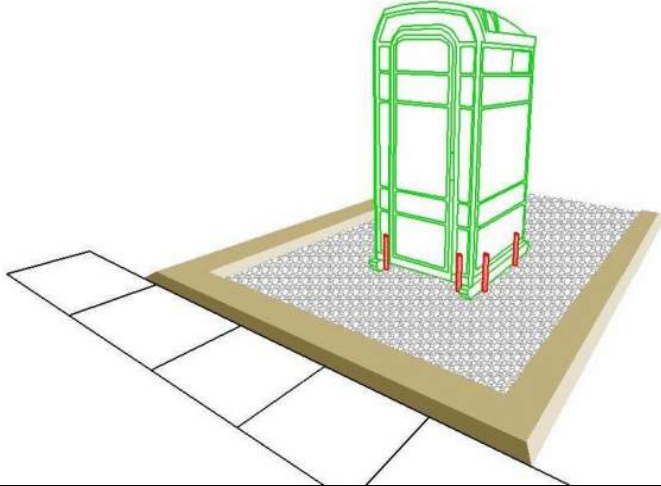

OBJECTIVES

- Housekeeping Practices
- Contain Waste
- Minimize Disturbed Areas
- Stabilize Disturbed Areas
- Protect Slopes/Channels
- Control Site Perimeter
- Control Internal Erosion

TARGETED POLLUTANTS

H M L

- Sediment
- Nutrients
- Heavy Metals
- Toxic Materials
- Oil & Grease
- Floatable Materials
- Bacteria & Viruses
- Other Waste

IMPLEMENTATION REQUIREMENTS

H M L

- Capital Costs
- O&M Costs
- Maintenance
- Training
- Staffing
- Administrative

H = High M = Medium L = Low

DESCRIPTION:

Temporary on-site sanitary facilities for construction personnel.

APPLICATION:

All sites with no permanent sanitary facilities or where permanent facility is too far from activities.

INSTALLATION / APPLICATION CRITERIA:

- Locate portable toilets in a convenient locations throughout the site
- Prepare level, gravel surface and provide clear access to the toilets for servicing and for on-site personnel
- Construct earth berm perimeter (see Earth Berm Barrier Sheet), control for spill / leak protection.
- Anchor the portable toilet to prevent tipping

LIMITATIONS:

No limitations

MAINTENANCE:

- Portable toilets should be maintained in good working order by licensed service with daily observation for leak detection
- Regular waste collection should be arranged with licensed service
- All waste should be deposited in sanitary sewer system for treatment with appropriate agency approval

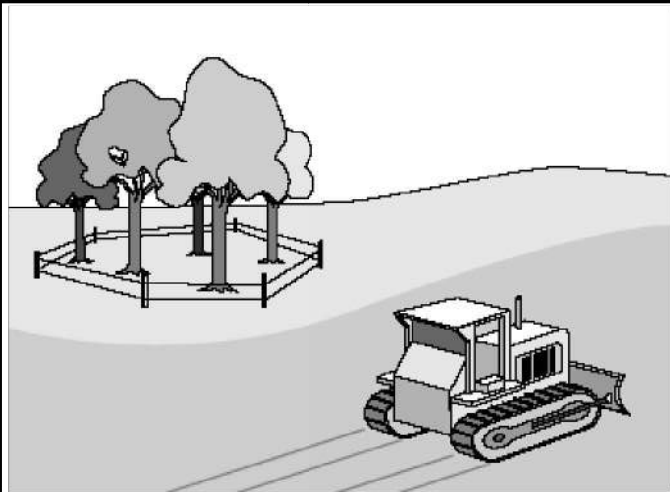

DESCRIPTION:

Carefully planned preservation of existing vegetation minimizes the potential of removing or injuring existing trees, vines, shrubs and/or grasses that serve as erosion controls.

APPLICATION:

This technique is applicable to all types of sites. Areas where preserving vegetation can be particularly beneficial are floodplains, wetlands, stream banks, steep slopes, and other areas where erosion controls would be difficult to establish, install, or maintain.

INSTALLATION / APPLICATION CRITERIA:

- Clearly mark, flag or fence vegetation or areas where vegetation should be preserved.
- Prepare landscaping plans which include as much existing vegetation as possible and state proper care during and after construction.
- Define and protect with berms, fencing, signs, etc. a setback area from vegetation to be preserved.
- Propose landscaping plans which do not include plant species that compete with the existing vegetation.
- Do not locate construction traffic routes, spoil piles, etc. where significant adverse impact on existing vegetation may occur.

LIMITATIONS:

- Requires forward planning by the owner/developer, contractor and design staff.
- For sites with diverse topography, it is often difficult and expensive to save existing trees while grading the site satisfactorily for the planned development.
- May not be cost effective with high land costs.

MAINTENANCE:

- Inspection and maintenance requirements for protection of vegetation are low.
- Maintenance of native trees or vegetation should conform to landscape plan specifications.

OBJECTIVES

- Housekeeping Practices
- Contain Waste
- Minimize Disturbed Areas
- Stabilize Disturbed Areas
- Protect Slopes/Channels
- Control Site Perimeter
- Control Internal Erosion

TARGETED POLLUTANTS

H M L

- Sediment
- Nutrients
- Heavy Metals
- Toxic Materials
- Oil & Grease
- Floatable Materials
- Bacteria & Viruses
- Other Waste

IMPLEMENTATION REQUIREMENTS

H M L

- Capital Costs
- O&M Costs
- Maintenance
- Training
- Staffing
- Administrative

H = High M = Medium L = Low

300

300

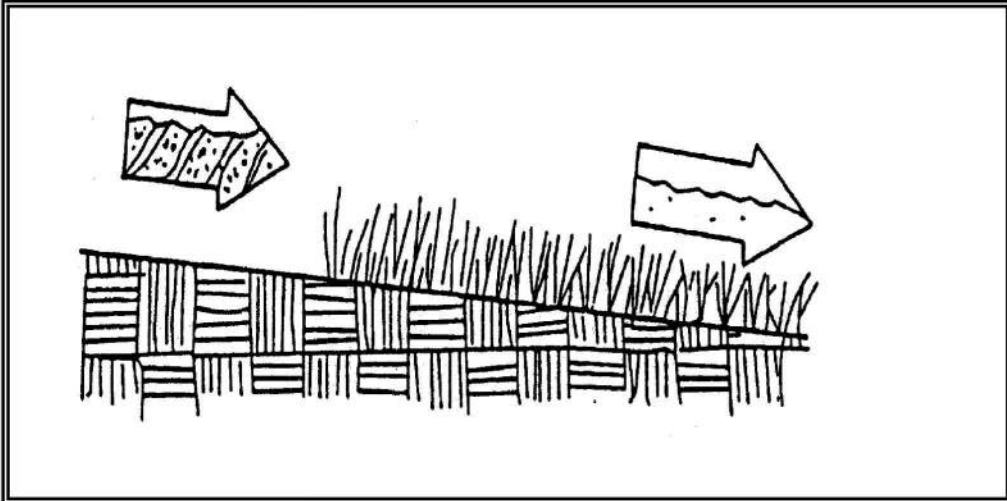

DESCRIPTION:

Seeding of grass and plantings of trees, shrubs, vines and ground covers provide long-term stabilization of soil. Grasses can be planted for temporary stabilization.

APPLICATION:

- ▶ Appropriate for site stabilization both during construction and post-construction.
- ▶ Any graded/cleared areas where construction activities have ceased.
- ▶ Open space cut and fill areas.
- ▶ Steep slopes, spoil piles, vegetated swales, landscape corridors, stream banks.

INSTALLATION/APPLICATION CRITERIA:

Type of vegetation, site and seedbed preparation, planting time, fertilization and water requirements should be considered for each application.

Grasses:

- ▶ Ground preparation: fertilize and mechanically stabilize the soil.
- ▶ Tolerant of short-term temperature extremes and waterlogged soil composition.
- ▶ Appropriate soil conditions: shallow soil base, good drainage, slope 2:1 or flatter.
- ▶ Mowing, irrigating, and fertilizing are vital for promoting vigorous grass growth.

Trees and Shrubs:

- ▶ Selection criteria: vigor, species, size, shape & wildlife food source.
- ▶ Soil conditions: select species appropriate for soil, drainage & acidity.
- ▶ Other factors: wind/exposure, temperature extremes, and irrigation needs.

Vines and Ground Covers:

- ▶ Ground preparation: lime and fertilizer preparation.
- ▶ Use proper seeding rates.
- ▶ Appropriate soil conditions: drainage, acidity and slopes.
- ▶ Generally avoid species requiring irrigation.

LIMITATIONS:

- ▶ Permanent and temporary vegetation may not be appropriate in dry periods without irrigation.
- ▶ Fertilizer requirements may have potential to create stormwater pollution.

MAINTENANCE:

- ▶ Shrubs and trees must be adequately watered and fertilized and if needed pruned.
- ▶ Grasses may need to be watered and mowed.

OBJECTIVES

- Housekeeping Practices
- Contain Waste
- Minimize Disturbed Areas
- Stabilize Disturbed Areas
- Protect Slopes/Channels
- Control Site Perimeter
- Control Internal Erosion



TARGETED POLLUTANTS

- Sediment
- Nutrients
- Toxic Materials
- Oil & Grease
- Floatable Materials
- Other Waste

- High Impact
- Medium Impact
- Low or Unknown Impact

IMPLEMENTATION REQUIREMENTS

- Capital Costs
- O&M Costs
- Maintenance
- Training

- High Medium Low



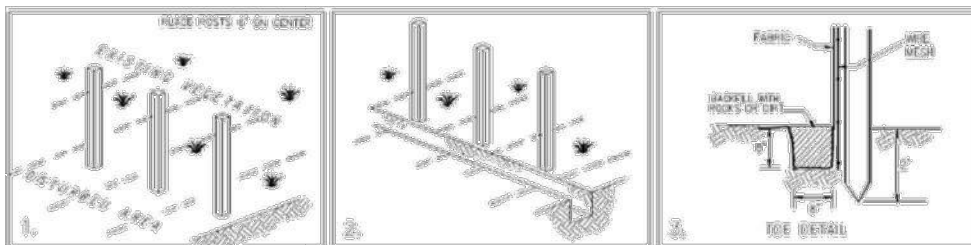

OBJECTIVES

- Housekeeping Practices
- Contain Waste
- Minimize Disturbed Areas
- Stabilize Disturbed Areas
- Protect Slopes/Channels
- Control Site Perimeter
- Control Internal Erosion

TARGETED POLLUTANTS

H M L

- Sediment
- Nutrients
- Heavy Metals
- Toxic Materials
- Oil & Grease
- Floatable Materials
- Bacteria & Viruses
- Other Waste

IMPLEMENTATION REQUIREMENTS

H M L

- Capital Costs
- O&M Costs
- Maintenance
- Training
- Staffing
- Administrative

H = High M = Medium L = Low



DESCRIPTION:

A temporary sediment barrier consisting of entrenched filter fabric stretched across and secured to supporting posts.

APPLICATION:

- Perimeter control: place barrier at downgradient limits of disturbance
- Sediment barrier: place barrier at toe of slope or soil stockpile
- Protection of existing waterways: place barrier at top of stream bank
- Inlet protection: place fence surrounding catch basins

INSTALLATION / APPLICATION CRITERIA:

- Place posts 6' apart on center along contour (or use preassembled unit) and drive 2' minimum into ground. Excavate an anchor trench immediately up gradient of posts
- Cut fabric to require width, unroll along length of barrier and drape over barrier. Secure fabric to mesh with twine, staples, or similar, with trailing edge extending into anchor trench
- Backfill trench over fabric to anchor
- Fabric must have 85% minimum sediment removal efficiency

LIMITATIONS:

- Recommended maximum drainage area of 0.5 acre per 100 feet
- Recommended maximum upgradient slope length of 150'
- Recommended maximum uphill grade of 2:1 (50%)
- Recommended maximum flow rate of 0.5 cfs
- Ponding should not be allowed behind fence

MAINTENANCE:

- Inspect immediately after any rainfall and at least daily during prolonged rainfall
- Look for runoff bypassing ends of barriers or undercutting barriers
- Repair or replace damaged areas of the barrier and remove accumulated sediment
- Reanchor fence as necessary to prevent shortcutting
- Remove accumulated sediment when it reaches 1/2 the height of the fence

GBB GRAVEL BAG BERM

A gravel bag berm consists of a single row of gravel bags that are installed end-to-end to form a barrier across a slope to intercept runoff, reduce runoff velocity, release runoff as sheet flow, and provide some sediment removal.

Applications

Along the top, face, and at grade breaks of exposed and erodible slopes

Key Points

Key Point #1 – Installation

Proper gravel bag berm installation is crucial to ensure its effectiveness and performance. Gravel bag berms should be placed on a level contour along the slope (Photo 1). Gravel bags should be tightly abutted together and not overlapped (Photo 2).



Photo 1



Photo 2

Key Point #2 – Bag Design

Bags should be made of a woven polypropylene, polyethylene or polyamide fabric, or burlap material. When full, a bag should be 450 mm (1.5 ft) long, 300 mm (1 ft) wide, and 75 mm (3 in) thick, with a mass of approximately 15 kg (35 lb). Bag dimensions are standardized but may vary based on locally available materials. Alternative bag sizes shall be submitted to the Resident Engineer for approval prior to deployment. Fill material shall be 13 mm to 25 mm (1/2 in to 1 in) class 2 aggregate base that is clean and free from clay and undesirable materials.

Key Point #3 – Sediment Control

Although gravel bag berms remove some sediment, they should not be used in place of linear sediment barriers.

Key Point #4 – Limitations

Gravel bags are sensitive to ultraviolet light resulting in a limited durability that may make them unsuitable for long-term projects. Gravel bag berms are labor intensive. Installation, removal, and maintenance costs should be evaluated when considering this BMP.

Key Point #5 – Inspection and Maintenance

Inspect gravel bag berms weekly and prior to and after rainfall events during the rainy season. Repair or replace broken or ripped bags, and reshape as necessary. Remove accumulated sediment when it reaches 1/3 the height of the berm. Repair washouts and rills as needed.

Preventive Measures and Troubleshooting Guide

Field Condition:	Common solutions are:
Runoff flows under the bags.	Ensure that bags are placed completely on the soil surface and not overlapped. Butt the bag ends together tightly. Repair rills and washouts.
Runoff flows around ends of bag rows.	Make sure that bags are placed on a level contour. Turn up ends of each row.
Runoff flows between bags.	Ensure that gravel bags are butted tightly together.
There is excessive sediment accumulation.	Remove accumulated sediment. Apply soil stabilization measures to contributing areas
Length of slope draining to gravel bag berm is too long.	Place berm at shorter intervals. The steeper the slope, the closer together the berms should be placed.

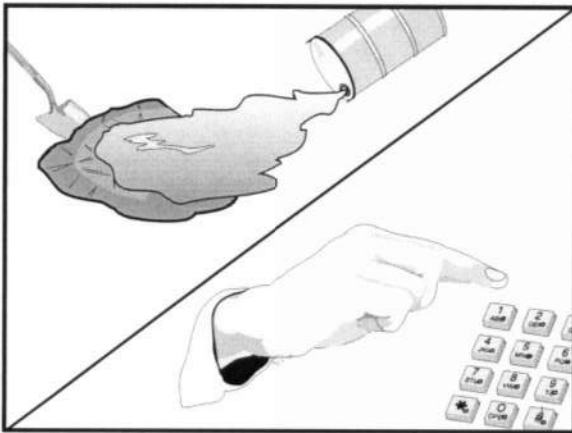

Standard Symbol

BMP Objectives

- Soil Stabilization
- Sediment Control
- Tracking Control
- Wind Erosion Control
- Non-Storm Water Management
- Materials and Waste Management

OBJECTIVES

- Housekeeping Practices
- Contain Waste
- Minimize Disturbed Areas
- Stabilize Disturbed Areas
- Protect Slopes/Channels
- Control Site Perimeter
- Control Internal Erosion

TARGETED POLLUTANTS

H M L

- Sediment
- Nutrients
- Heavy Metals
- Toxic Materials
- Oil & Grease
- Floatable Materials
- Bacteria & Viruses
- Other Waste

DESCRIPTION:

Practices to clean-up leakage/spillage of on-site materials that may be harmful to receiving waters.

APPLICATION:

All sites

GENERAL:

- Store controlled materials within a storage area
- Educate personnel on prevention and clean-up
- Designate an Emergency Coordinator responsible practices and for providing spill response
- Maintain a supply of clean-up equipment on-site response agencies with phone numbers

METHODS:

- Clean-up spills/leaks immediately and remediate cause
- Use as little water as possible. NEVER HOSE DOWN OR BURY SPILL CONTAMINATED MATERIAL
- Use rags or absorbent material for clean-up. Excavate contaminated soils. Dispose of clean-up material and soil as hazardous waste
- Document all spills with date, location, substance, volume, actions taken and other pertinent data.
- Contact local Fire Department and State Division of Environmental Response and Remediation (Phone #536-4100) for any spill of reportable quantity

IMPLEMENTATION REQUIREMENTS

H M L

- Capital Costs
- O&M Costs
- Maintenance
- Training
- Staffing
- Administrative

H = High M = Medium L = Low

SCU

SCU

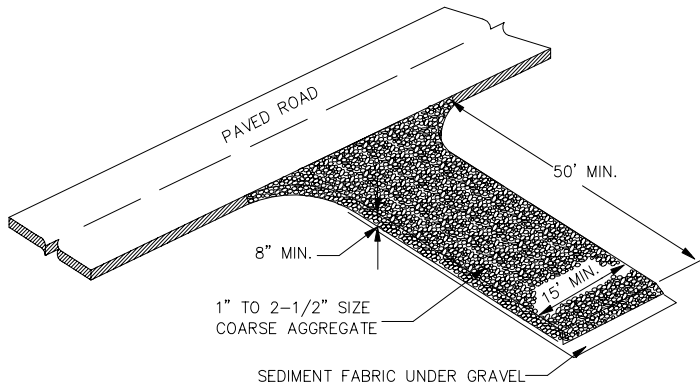

OBJECTIVES

- Housekeeping Practices
- Contain Waste
- Minimize Disturbed Areas
- Stabilize Disturbed Areas
- Protect Slopes/Channels
- Control Site Perimeter
- Control Internal Erosion

DESCRIPTION:

A stabilized pad of crushed stone located where construction traffic enters or leaves the site from or to paved surface.

APPLICATIONS:

At any point of ingress or egress at a construction site where adjacent traveled way is paved. Generally applies to sites over 2 acres unless special conditions exist.

INSTALLATION/APPLICATION CRITERIA:

- ▶ Clear and grub area and grade to provide maximum slope of 2%.
- ▶ Compact subgrade and place filter fabric if desired (recommended for entrances to remain for more than 3 months).
- ▶ Place coarse aggregate, 1 to 2-1/2 inches in size, to a minimum depth of 8 inches.

LIMITATIONS:

- ▶ Requires periodic top dressing with additional stones.
- ▶ Should be used in conjunction with street sweeping on adjacent public right-of-way.

MAINTENANCE:

- ▶ Inspect daily for loss of gravel or sediment buildup.
- ▶ Inspect adjacent roadway for sediment deposit and clean by sweeping or shoveling.
- ▶ Repair entrance and replace gravel as required to maintain control in good working condition.
- ▶ Expand stabilized area as required to accommodate traffic and prevent erosion at driveways.

TARGETED POLLUTANTS

- Sediment
- Nutrients
- Toxic Materials
- Oil & Grease
- Floatable Materials
- Other Waste

- High Impact
- Medium Impact
- Low or Unknown Impact

IMPLEMENTATION REQUIREMENTS

- Capital Costs
- O&M Costs
- Maintenance
- Training

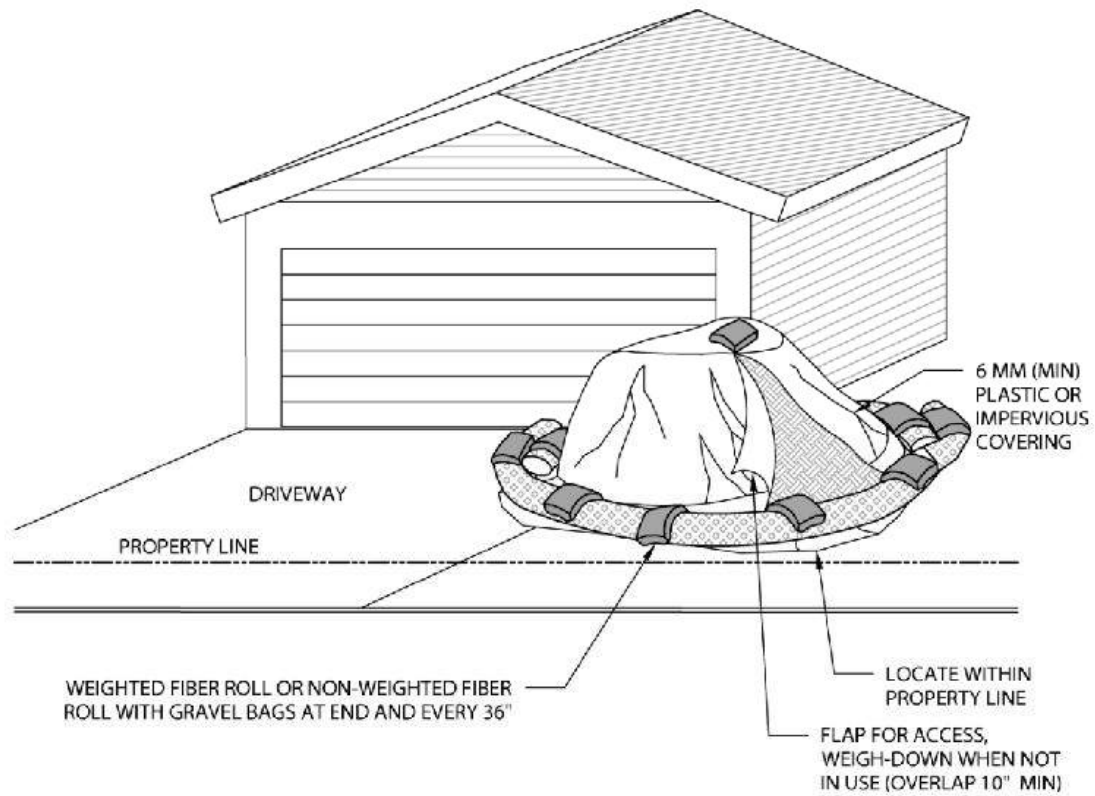

NOTES:

1. LOCATE STOCK AND/OR SPOIL PILES AWAY FROM DRAINAGE COURSES, DRAIN INLETS OR CONCENTRATED FLOWS OF STORMWATER.
2. ALL STOCK AND/OR SPOIL PILE PERIMETERS SHALL BE PROTECTED WITH TEMPORARY LINEAR SEDIMENT BARRIERS.
3. COVER ALL STOCK AND/OR SPOIL PILES WITH 6 MM PLASTIC, CANVAS TARP OR IMPERVIOUS COVER TO PREVENT WIND AND RAIN EROSION. EVENLY SPACE WEIGHTS (GRAVEL BAGS) ON COVER TO KEEP IN PLACE DURING WIND.
4. CONDUCT REGULAR INSPECTIONS OF STOCK AND/OR SPOIL PILES DURING AND AFTER RAIN EVENTS
5. VERY LARGE STOCK AND/OR SPOIL PILES MAY REQUIRE SILT FENCE IN LIEU OF FIBER ROLLS.
6. REMOVE SPOIL PILES FROM CONSTRUCTION SITE AS SOON AS POSSIBLE.
7. STOCK/SPOIL PILES MUST BE STORED WITHIN THE APPROVED STAGING AREA.

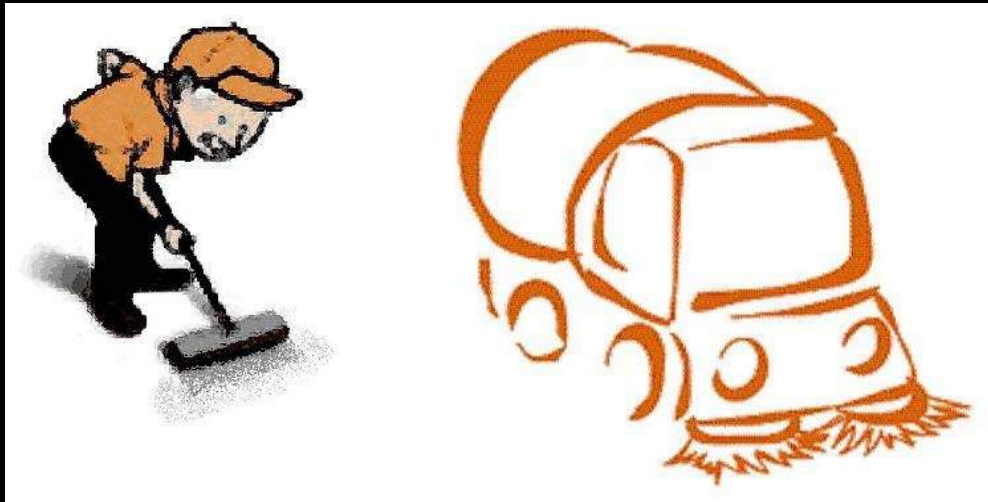

OBJECTIVES

- Housekeeping Practices
- Contain Waste
- Minimize Disturbed Areas
- Stabilize Disturbed Areas
- Protect Slopes/Channels
- Control Site Perimeter
- Control Internal Erosion

TARGETED POLLUTANTS

H M L

- Sediment
- Nutrients
- Heavy Metals
- Toxic Materials
- Oil & Grease
- Floatable Materials
- Bacteria & Viruses
- Other Waste

IMPLEMENTATION REQUIREMENTS

H M L

- Capital Costs
- O&M Costs
- Maintenance
- Training
- Staffing
- Administrative

H = High M = Medium L = Low

DESCRIPTION:

Prevent sediment from entering storm water by sweeping the streets near construction activities.

APPLICATION:

- Useful for any paved streets near construction sites where sediment is blown, tracked, or spilled onto the streets. Also, utilize for parking and other paved areas with sediment/debris accumulation.

INSTALLATION / APPLICATION CRITERIA:

- The equipment used should be appropriate for the conditions. Vacuum sweepers work more effectively when the area is dry. Brush sweepers work better when the sediment is wet or stuck to the surface.
- Mechanical equipment should be operated and maintained according to the manufacturer's recommendations
- Manually sweep with broom if mechanical sweepers are unable to reach certain areas or when impractical to utilize vehicular sweepers.

LIMITATIONS:

- Is labor and equipment intensive
- May cause dust

MAINTENANCE:

- The street should be checked daily for any sediment deposits. Street sweeping should be implemented whenever sediment from construction activity is found on the streets

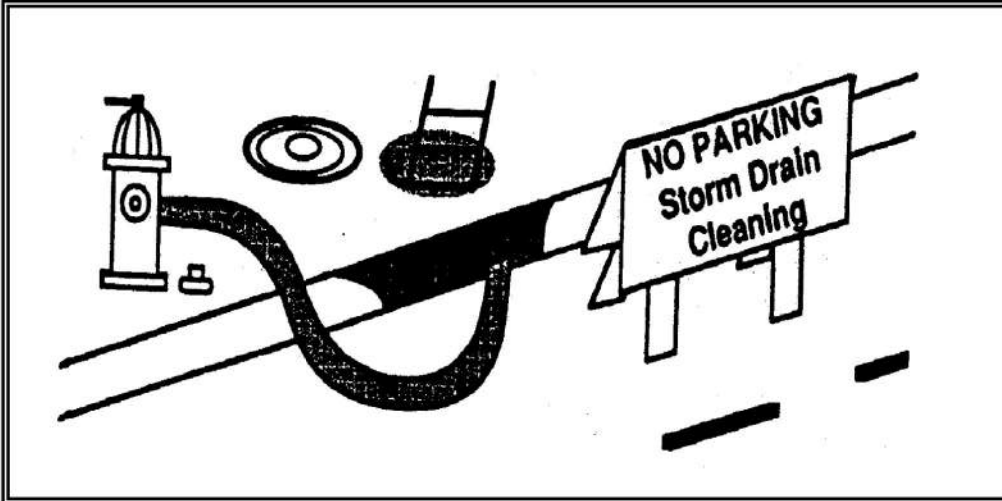

DESCRIPTION:

A storm drain is "flushed" with water to suspend and remove deposited materials. Flushing is particularly beneficial for storm drain pipes with grades too flat to be self-cleansing. Flushing helps ensure pipes convey design flow and remove pollutants from the storm drain system.

APPROACH:

- ▶ Locate reaches of storm drain with deposit problems and develop a flushing schedule that keeps the pipe clear of excessive buildup.
- ▶ Whenever possible, flushed effluent should be collected, decanted, evaporated, and disposed of in a landfill.

LIMITATIONS:

- ▶ Most effective in small diameter pipes (36-inch diameter pipe or less, depending on water supply and sediment collection capacity).
- ▶ Water source must be available.
- ▶ May have difficulty finding downstream area to collect sediments.
- ▶ Requires liquid/sediment disposal.

PROGRAM ELEMENTS

- New Development
- Residential
- Commercial Activities
- Industrial Activities
- Municipal Facilities
- Illegal Discharges

TARGETED POLLUTANTS

- Sediment
- Nutrients
- Heavy Metals
- Toxic Materials
- Oxygen Demanding Substances
- Oil & Grease
- Floatable Materials
- Bacteria & Viruses

- High Impact
- Medium Impact
- Low or Unknown Impact

IMPLEMENTATION REQUIREMENTS

- Capital Costs
- O&M Costs
- Regulatory
- Training
- Staffing
- Administrative

- High
- Medium
- Low

Handwritten signature



Used oil can be disposed of at a waste collection facility, where it will be collected and later sent to a recycling facility

APPLICATIONS

- Manufacturing
- Material Handling
- Vehicle Maintenance
- Construction
- Commercial Activities
- Roadways
- Waste Containment
- Housekeeping Practices

DESCRIPTION:

Used motor oil is a hazardous waste because it contains heavy metals picked up from the engine during use. Since it is toxic to humans, wildlife, and plants, it should be disposed of at a local recycling or disposal facility or by contracting with an outside firm specializing in recycling or disposing of this material.

APPROACH:

- When establishing oil recycling programs, municipalities should provide the public with the proper informational resources.
- The public can also call 1-800-RECYCLE or contact Earth's 911 at www.1800cleanup.org/ for more information.
- Municipalities also need to address oil filter recycling in their recycling programs.
- To make recycling motor oil more convenient for the do-it-yourselfers, oil recycling programs should be located throughout all communities.
- Two types of programs currently in use are drop-off locations and curbside collection. Drop-off locations include service stations, recycling centers, auto parts retail stores, quick lubes, and landfills.

LIMITATIONS:

- If oil is mixed with other substances or if storage containers have residues of other substances, this can contaminate oil and make it a hazardous waste.
- It is often difficult to effectively educate the public and convince them of the importance of recycling oil. This limitation can be addressed if municipalities include recycling information in utility bill inserts, newspaper ads, and mailings.

MAINTENANCE:

- Costs for used motor oil recycling programs vary depending on whether a community has already established similar types of recycling programs.
- Major costs associated with oil recycling programs include advertisement costs and oil collection costs.

TARGETED POLLUTANTS

- Sediment
- Nutrients
- Heavy Metals
- Toxic Materials
- Oxygen Demanding Substances
- Oil & Grease
- Floatable Materials
- Bacteria & Viruses

<ul style="list-style-type: none"> <input checked="" type="checkbox"/> High Impact <input checked="" type="checkbox"/> Medium Impact <input type="checkbox"/> Low or Unknown Impact
--

IMPLEMENTATION REQUIREMENTS

- Capital Costs
 - O&M Costs
 - Maintenance
 - Training
- | | | |
|--|--|------------------------------|
| <input checked="" type="checkbox"/> High | <input checked="" type="checkbox"/> Medium | <input type="checkbox"/> Low |
|--|--|------------------------------|

OBJECTIVES

- Housekeeping Practices
- Contain Waste
- Minimize Disturbed Areas
- Stabilize Disturbed Areas
- Protect Slopes/Channels
- Control Site Perimeter
- Control Internal Erosion

TARGETED POLLUTANTS

H M L

- Sediment
- Nutrients
- Heavy Metals
- Toxic Materials
- Oil & Grease
- Floatable Materials
- Bacteria & Viruses
- Other Waste

IMPLEMENTATION REQUIREMENTS

H M L

- Capital Costs
- O&M Costs
- Maintenance
- Training
- Staffing
- Administrative

H = High M = Medium L = Low

Handwritten signature

Handwritten signature

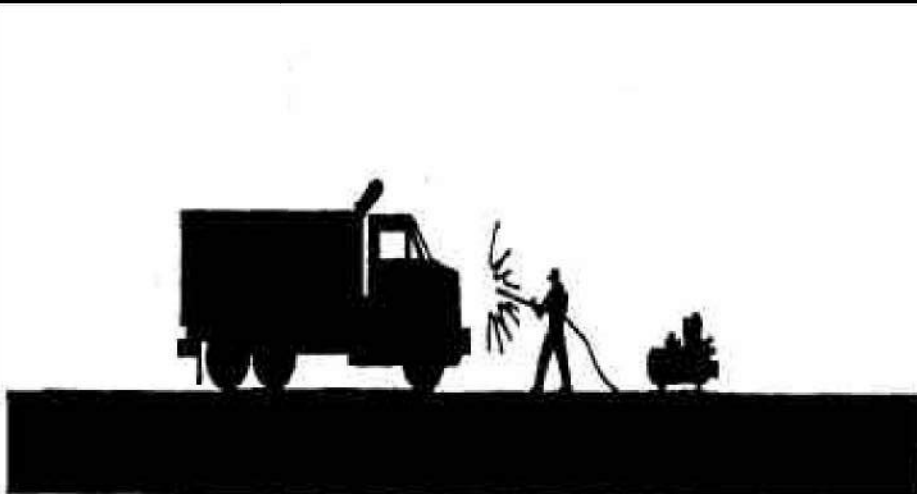

DESCRIPTION:

Prevent or reduce the discharge of pollutants to storm water from vehicle and equipment cleaning by using off-site facilities, washing in designated, contained areas only, eliminating discharges to the storm drain by infiltrating or recycling the wash water, and/or training employees and subcontractors.

INSTALLATION / APPLICATION CRITERIA:

- Use off-site commercial washing businesses as much as possible. Washing vehicles and equipment outdoors or in areas where wash water flows onto paved surfaces or into drainage pathways can pollute storm water. If you wash large number of vehicles or pieces of equipment, consider conducting this work at an off-site commercial business. These businesses are better equipped to handle and dispose of the wash waters properly. Performing this work off-site can also be economical by eliminating the need for a separate washing operation at your site.
- If washing must occur on-site, use designated, bermed wash areas to prevent wash water contact with storm water, creeks, rivers, and other water bodies. The wash area can be sloped for wash water collection and subsequent infiltration into the ground.
- Use as little water as possible to avoid having to install erosion and sediment controls for the wash area. Use phosphate-free biodegradable soaps. Educate employees and subcontractors on pollution prevention measures. Do not permit steam cleaning on-site. Steam cleaning can generate significant pollutant concentrations.

LIMITATIONS:

- Even phosphate-free, biodegradable soaps have been shown to be toxic to fish before the soap degrades
- Sending vehicles/equipment off-site should be done in conjunction with Stabilized Construction Entrance

MAINTENANCE:

- Minimal, some berm repair may be necessary

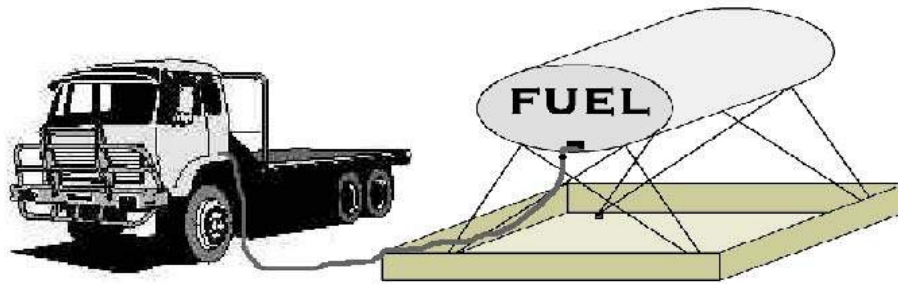

OBJECTIVES

- Housekeeping Practices
- Contain Waste
- Minimize Disturbed Areas
- Stabilize Disturbed Areas
- Protect Slopes/Channels
- Control Site Perimeter
- Control Internal Erosion

TARGETED POLLUTANTS

H M L

- Sediment
- Nutrients
- Heavy Metals
- Toxic Materials
- Oil & Grease
- Floatable Materials
- Bacteria & Viruses
- Other Waste

IMPLEMENTATION REQUIREMENTS

H M L

- Capital Costs
- O&M Costs
- Maintenance
- Training
- Staffing
- Administrative

H = High M = Medium L = Low

DESCRIPTION:

Prevent fuel spills and leaks, and reduce their impacts to storm water by using offsite facilities, fueling in designated areas only, enclosing or covering stored fuel, implementing spill controls, and training employees and subcontractors.

INSTALLATION / APPLICATION CRITERIA:

- Use off-site fueling stations as much as possible. Fueling vehicles and equipment outdoors or in areas where fuel may spill/leak onto paved surfaces or into drainage pathways can pollute storm water. If you fuel a large number of vehicles or pieces of equipment, consider using an off-site fueling station. These businesses are better equipped to handle fuel and spills properly. Performing this work off-site can also be economical by eliminating the need for a separate fueling area at your site.
- If fueling must occur on-site, use designated areas, located away from drainage courses, to prevent the run on of storm water and the runoff of spills. Discourage "topping-off" of fuel tanks.
- Always use secondary containment, such as a drain pan or drop cloth, when fueling to catch spills/leaks. Place a stockpile of spill cleanup materials where it will be readily accessible. Use adsorbent materials on small spills rather than hosing down or burying the spill. Remove the adsorbent materials promptly and dispose of properly.
- Carry out all Federal and State requirements regarding stationary above ground storage tanks.(40 CF Sub. J) Avoid mobile fueling of mobile construction equipment around the site; rather, transport the equipment to designated fueling areas. With the exception of tracked equipment such as bulldozers and perhaps forklifts, most vehicles should be able to travel to a designated area with little lost time. Train employees and subcontractors in proper fueling and cleanup procedures.

LIMITATIONS:

Sending vehicles/equipment off-site should be done in conjunction with Stabilized Construction Entrance

MAINTENANCE:

- Keep ample supplies of spill cleanup materials on-site
- Inspect fueling areas and storage tanks on a regular schedule

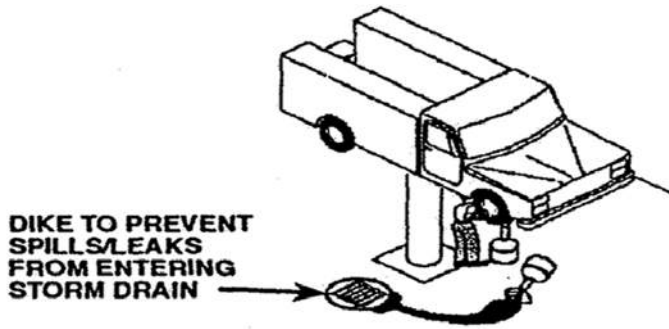

(INSIDE MAINTENANCE FACILITY)

APPLICATIONS

- Manufacturing
- Material Handling
- Vehicle Maintenance
- Construction
- Commercial Activities
- Roadways
- Waste Containment
- Housekeeping Practices

DESCRIPTION:

Prevent or reduce the discharge of pollutants to stormwater from vehicles and equipment maintenance and repair by running a dry shop.

APPROACH:

- ▶ Keep equipment clean, don't allow excessive build-up of oil and grease.
- ▶ Keep drip pans or containers under the areas that might drip.
- ▶ Do not change motor oil or perform equipment maintenance in non-appropriate areas.
- ▶ Inspect equipment for leaks on a regular basis.
- ▶ Segregate wastes.
- ▶ Make sure oil filters are completely drained and crushed before recycling or disposal.
- ▶ Make sure incoming vehicles are checked for leaking oil and fluids.
- ▶ Clean yard storm drain inlets regularly and especially after large storms.
- ▶ Do not pour materials down drains or hose down work areas; use dry seeping.
- ▶ Store idle equipment under cover.
- ▶ Drain all fluids from wrecked vehicles.
- ▶ Recycle greases, used oil or oil filters, antifreeze, cleaning solutions, automotive batteries, hydraulic, and transmission fluids.
- ▶ Switch to non-toxic chemicals for maintenance when possible.
- ▶ Clean small spills with rags, general clean-up with damp mops and larger spills with absorbent material.
- ▶ Paint signs on storm drain inlets to indicate that they are not to receive liquid or solid wastes.
- ▶ Train employees, minimize use of solvents.

LIMITATIONS:

- ▶ Space and time limitations may preclude all work being conducted indoors.
- ▶ It may not be possible to contain and clean up spills from vehicles/equipment brought on-site after working hours.
- ▶ Dry pans are generally too small to contain antifreeze, which may gush from some vehicles, so drip pans may have to be purchased or fabricated.
- ▶ Dry floor cleaning methods may not be sufficient for some spills.

MAINTENANCE:

Should be low if procedures for the approach are followed.

TARGETED POLLUTANTS

- Sediment
- Nutrients
- Heavy Metals
- Toxic Materials
- Oxygen Demanding Substances
- Oil & Grease
- Floatable Materials
- Bacteria & Viruses

- High Impact
- Medium Impact
- Low or Unknown Impact

IMPLEMENTATION REQUIREMENTS

- Capital Costs
- O&M Costs
- Maintenance
- Training

- High
- Medium
- Low

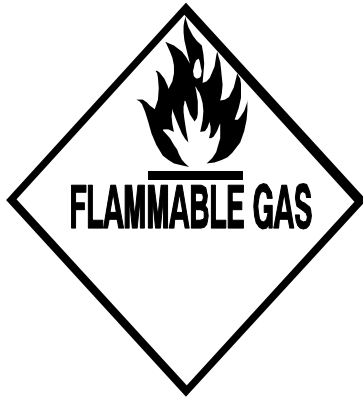

APPLICATIONS

- Manufacturing
- Material Handling
- Vehicle Maintenance
- Construction
- Commercial Activities
- Roadways
- Waste Containment
- Housekeeping Practices

DESCRIPTION:

Prevent or reduce the discharge of pollutants to stormwater from waste handling and disposal; reducing waste generation and disposal through source reduction, re-use, and recycling; and preventing runoff and runoff from waste management areas.

APPROACH:

- ▶ Substitute or eliminate raw materials.
- ▶ Modify process or equipment.
- ▶ SARA Title III, Section 313 requires reporting for over 300 listed chemicals and chemical compounds. This requirement should be used to track these chemicals although this is not as accurate a means of tracking as other approaches.
- ▶ Use design data and review: process flow diagram, materials and applications diagram, piping and instructions, equipment list, plot plan.
- ▶ Use economic data and review: Waste treatment and disposal cost. Product utility and economic cost. Operation and maintenance labor cost.
- ▶ Recycle materials whenever possible.
- ▶ Segregation and separate waste.
- ▶ Cover, enclose, or berm industrial wastewater management areas whenever possible to prevent contact with runoff or runoff.
- ▶ Equip waste transport vehicles with anti-spill equipment.
- ▶ Minimize spills and fugitive losses such as dust or mist from loading systems.
- ▶ Ensure that sediments or wastes are prevented from being tracked off-site.
- ▶ Training and supervision.
- ▶ Stencil storm drains on the facility's property with prohibitive message regarding waste disposal.

LIMITATIONS:

Hazardous waste that cannot be re-used or recycled must be disposed of by a licensed hazardous waste hauler.

TARGETED POLLUTANTS

- Sediment
- Nutrients
- Heavy Metals
- Toxic Materials
- Oxygen Demanding Substances
- Oil & Grease
- Floatable Materials
- Bacteria & Viruses

- High Impact
- Medium Impact
- Low or Unknown Impact

IMPLEMENTATION REQUIREMENTS

- Capital Costs
- O&M Costs
- Maintenance
- Training

- High
- Medium
- Low

Appendix I: Construction General Permit

If all storm water team members access the CGP via the internet while on site the following link to access the Construction General Permit is sufficient:

<http://construction.stormwater.utah.gov>

Otherwise, include a printed out copy of the Construction General Permit in this appendix.