



Storm Water Pollution Prevention Plan

SWPPP Link:



Project:

KHR Holdings
9350 W 791 S
West Weber, UT
84404

24 Hour Contact:

John Barlow
Silverbrook Construction
(970) 799-2042
JohnB@Silverbrook.US

SWPPP Contact(s):

Erosion Control Services
Ben Caamano
385-204-8916
Office@ErosionControlServices.Net

SWPPP Preparation Date: 10/20/2022

Estimated Dates

Project Start: 10/26/2022
Project Completion: 4/2/2023

Storm Water Pollution Prevention Plan

for:

KHR Holdings
Ryan Brown or Chadwick Spencer
9350 W 791 S
West Weber County, Utah
801-514-6406

Operator:

Silverbrook Construction
Johnathan Barlow
PO Box 423
Fillmore, UT 84631
970-779-2042
JohnB@Silverbrook.us

Primary SWPPP Contact

Erosion Control Services
Danielle Roundy RSW
PO Box 1154
Riverton Utah 84065
801-302-3021
office@erosioncontrolservices.net

SWPPP Preparation Date:

10/20/2022

UPDES Permit Tracking Number*:

UTRC06043

Contents

SECTION 1: CONTACT INFORMATION/ RESPONSIBLE PARTIES	1
1.1 Storm Water Team	1
SECTION 2: NATURE OF CONSTRUCTION ACTIVITIES	3
2.1 Construction Site Estimates	3
2.2 Construction Activity Descriptions	3
2.3 Phase/Sequence of Construction Activity	4
2.4 Maps	5
SECTION 3: WATER QUALITY	6
3.1 Discharge Information	6
3.2 Receiving Waters	6
3.3 Impaired Waters	6
3.4 High Water Quality	6
4.1 Potential Sources of Pollution	7
4.2 Non-Storm Water Discharges	9
4.3 Dewatering Practices	10
4.4 Natural Buffers or Equivalent Sediment Controls	10
SECTION 5: EROSION AND SEDIMENT CONTROLS – BMPS	11
5.1 List of Erosion and Sediment BMPs on Site	11
5.2 Linear Site Perimeter Control Exemption	14
5.3 Final Stabilization	15
SECTION 6: BMPS - POLLUTION PREVENTION/OPERATIONAL CONTROLS	16
6.1 Spill Prevention and Response	16
6.2 Pollution Prevention Controls	17
SECTION 7: SPECIAL CONDITIONS	19
7.1 Emergency Related Projects	19
7.2 UIC Class 5 Injection Wells	19
7.3 Chemical Treatment	20
SECTION 8: INSPECTIONS & CORRECTIVE ACTIONS	21
8.1 Inspections	21
8.2 Corrective Actions	22
8.3 Delegation of Authority	22
SECTION 9: RECORDKEEPING	23
9.1 Recordkeeping	23
9.2 Log of Changes to the SWPPP	24
SECTION 10: CERTIFICATION	25
SECTION 11: SWPPP PREPARER CERTIFICATION	28
Appendix A – Site Maps	
Appendix B – NOI	
Appendix C – Inspection Reports	
Appendix D –Corrective Action Report	
Appendix E – Subcontractor Certifications/Agreements/Delegation of Authority	
Appendix F – Training Logs (CGP Part 6) and Certifications	
Appendix G – Additional Information (i.e., Other permits and out of date SWPPP documents)	
Appendix H – BMP Specifications	
Appendix I – Construction General Permit	

SECTION 1: CONTACT INFORMATION/ RESPONSIBLE PARTIES

1.1 Storm Water Team

Name and/or Position, and Contact	Responsibilities, Qualifications, and Training
<p>Johnathan Barlow Silverbrook Construction Project Manager/Superintendent 970-779-2042 Johnb@Silverbrook.us</p>	<p>SWPPP Oversight Project Oversight – Daily Visual Inspections – BMP Maintenance</p>
<p>Anthony Miramontes Erosion Control Services 385-234-7915 Office@erosioncontrolservices.net</p>	<p>Inspections / Installation & Maintenance RSI</p>
<p>Jake Kelsch Erosion Control Services 801-554-9632 Office@erosioncontrolservices.net</p>	<p>Inspections / Installation & Maintenance RSI, CISEC</p>
<p>Ben Camaano Erosion Control Services 801-918-1212 office@erosioncontrolservices.net</p>	<p>Inspections/ Installation & Maintenance RSI</p>
<p>Bobby Harding Erosion Control Services 385-865-3370 Office@erosioncontrolservices.net</p>	<p>Inspections RSI</p>
<p>Kazen Roundy Erosion Control Services 801-615-3850 office@erosioncontrolservices.net</p>	<p>Inspections RSI</p>
<p>Charlie Giese Erosion Control Services 801-656-7062 office@erosioncontrolservices.net</p>	<p>Inspections RSI</p>
<p>Austin Aagard Erosion Control Services 801-326-9149 office@erosioncontrolservices.net</p>	<p>Inspections RSI</p>

Ryan Akam Erosion Control Services 385-732-3781 office@erosioncontrolservices.net	Inspections RSI
Dallas Aagard Erosion Control Services 801-842-5017 office@erosioncontrolservices.net	Inspections RSI
Trevor Newsome Erosion Control Services 801-472-7627 office@erosioncontrolservices.net	Inspections RSI

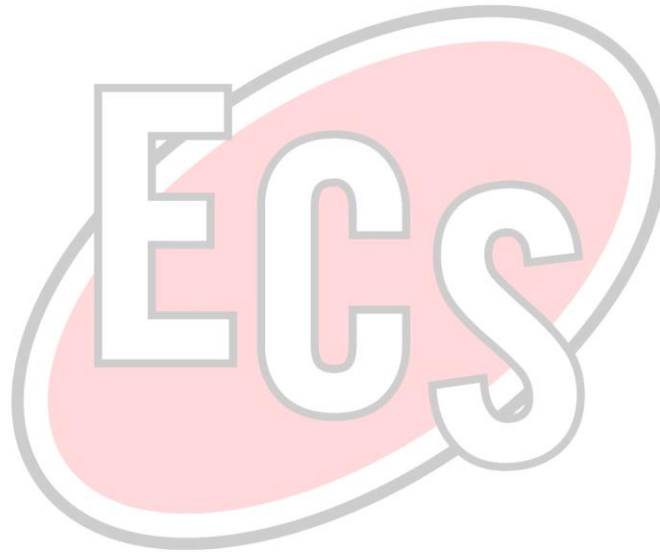

SECTION 2: NATURE OF CONSTRUCTION ACTIVITIES

2.1 Construction Site Estimates

The following are estimates for the construction site.

Total project area (lot size):	9.649 acres
Construction site area to be disturbed:	6.9 acres

2.2 Construction Activity Descriptions

Describe the general scope of the work for the project, major phases of construction, etc:

Construction of new Commercial Building.

Describe any on-site and off-site construction support activity areas:

Material storage will be onsite (location will be determined at the beginning of construction)

Typical site business days and times:

Mon-Fri 7-6

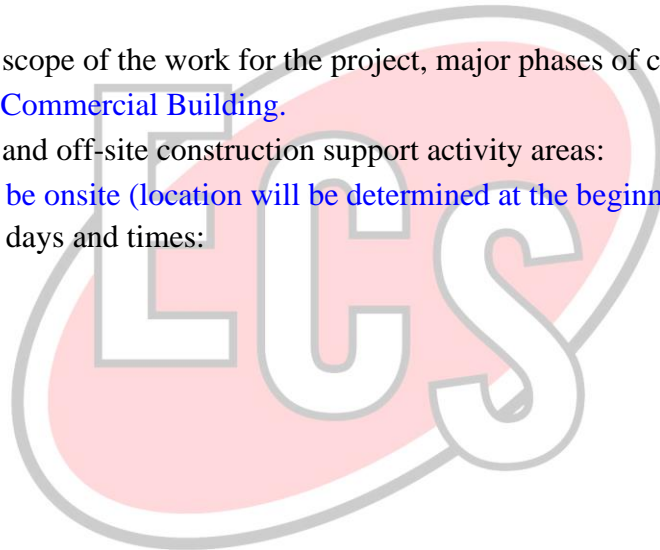

2.3 Phase/Sequence of Construction Activity

Phase I - Site Prep

- Grading and earthwork
- Clearing and Grubbing
- Vehicle and Equipment Mobilization
- 10/26/2022-11/26/2022

Phase II – Mass Grading

- Excavating
- Cutting & Filling
- Sediment import & Export
- Removal and relocation of Detention/retention pond
- 11/27/2022-12/27/2022

Phase III - Utilities

- Utility installs (Sanitary Sewer, Culinary water, ect)
- Concrete & Asphalt
- Curb and Gutter
- 12/28/2022-1/28/2023

Phase IV – Vertical Construction

- Framing
- Roofing
- Mortar/Stucco/Painting (Exterior Work)
- 1/29/2023-3/15/2023

Phase V – Final Stabilization

- Final Grading
- 3/15/2023-4/2/2023

2.4 Maps

The SWPPP site map(s) are filed in Appendix A

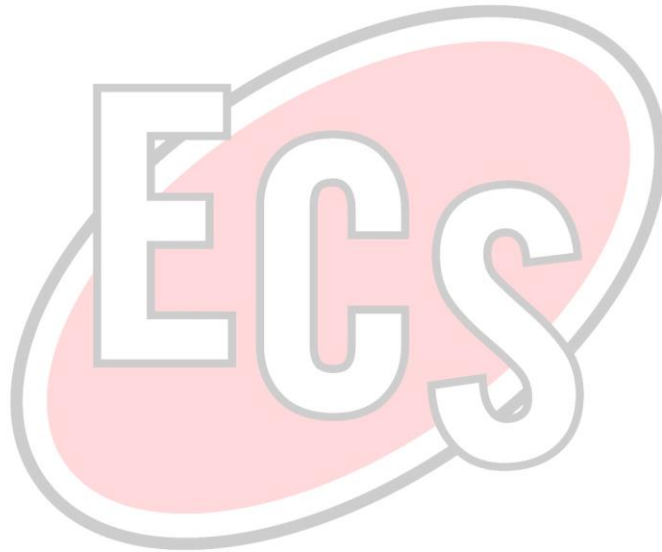

SECTION 3: WATER QUALITY

3.1 Discharge Information

Does your project/site discharge storm water into a Municipal Separate Storm Sewer System (MS4)? Yes No

List the MS4 that receives the discharge from the construction project:

3.2 Receiving Waters

Names of Receiving Waters

Name of Receiving Water (first surface water that receives storm water or where storm system discharges to)	Is the water impaired or high quality?	If high quality: Is it Category 1 or 2? If impaired: List pollutants that the waterbody is impaired for
1. Weber River	<input type="checkbox"/> Not high quality/impaired <input checked="" type="checkbox"/> Impaired, has approved TMDL <input type="checkbox"/> Impaired, no TMDL <input type="checkbox"/> High quality	N/A

3.3 Impaired Waters

Description of additional precautions taken if you are discharging to an impaired surface water. State if no impairment causing pollutants are on site: N/A

3.4 High Water Quality

Description of additional precautions taken to minimize pollution effects if you are discharging to a high quality surface water: N/A

SECTION 4: POLLUTION PREVENTION STANDARDS

4.1 Potential Sources of Pollution

Pollutants or Pollutant Constituents (that could be discharged if exposed to storm water)	Pollutant-Generating Activity	Location on Site (or reference SWPPP site map where this is shown)
Sediment / TSS (Total Suspended Solids)	Erosion where soil is disturbed because of construction presents potential problems of sediment and suspended solids due to runoff. Erosion/Sediment controls described on site map will be utilized.	Grading where building and asphalt will go in, stockpiles of sediment at staging area, and landscaping areas surrounding where the asphalt ends.
Soil Stabilization Material	Disturbed areas where slopes or susceptible soil types are exposed. Install Sediment/Pollutant control where material is present up-slope.	Anywhere earth has been disturbed that is not being completed with building, paving, or asphalt. More specifically surrounding asphalt.
Concrete-white / Solid grey-limestone, sand, pH, Chromium	Concrete found in curb, gutter, sidewalk, walkway, and parking garage areas on project and on vertical footing foundations. Excess and extra concrete will be cleaned up or dumped in designated area.	Concrete washout found at staging area.
Oils-brown oily petroleum hydrocarbon-Mineral Oil	During street production and roofing of structures activities. Paving operations will not be performed immediately before an anticipated major storm event.	Asphalt to connect to existing asphalt and to be completed around perimeter of curbs to form small perimeter parking.
Grease	Vehicles performing earth moving and construction activities-also steel and drilling work. Clean up where visual and keep equipment clean and wiped down.	At staging/material storage/parking location noted near entrance on BMP map
Refrigerants	AC units. Any AC servicing will be performed by HVAC trained technicians.	Roof of building (TBD)
Fuels-colorless-pale brown/yellow-pink-blue green hydrocarbon-Benzene, ethyl benzene, toluene, xylene, MTBE, petroleum distillate, oils/greases, naphthalene, coal oil	Used by vehicles performing dirt work and construction activities. Secondary containment will be provided for tanks to contain leaks and spills.	At staging/material storage/parking location noted near entrance on BMP map

Pollutants or Pollutant Constituents (that could be discharged if exposed to storm water)	Pollutant-Generating Activity	Location on Site (or reference SWPPP site map where this is shown)
Trash	Trash from empty cardboard, paint, plastic, scrap wood, and metal containers. Will be properly contained on the site and removed frequently for off-site disposal.	Construction dumpster at staging/material storage/parking location noted near entrance on BMP map
Stucco, Painting, Stone, Brick, Wash Waters	Structure's exterior finishing. Contained on the site in designated areas where possible.	Staging area
Pesticides-insecticides, fungicides, herbicides, - Chlorinated Hydrocarbons, organophosphates, carbonates, arsenic	Pesticides may be used as a preparation before the foundation is poured and for pest control during construction to control fire ants, etc. Herbicides also used for noxious weed control. Pesticides will be used according to the manufacturer's labeled instructions, and will not be applied just before a storm event. Excess pesticides will be removed from the site once application is complete.	Will be used in landscaped area surrounding the buildings asphalt when completed and will be stored in staging area.
Concrete Curing Compound-creamy white liquid-Naphtha	Curing compound will be used as needed. Concrete contractor will remove remaining compound from the site.	Near building foundation, and curbs surrounding building
Concrete Washout Waters-grey liquid-pH	Concrete trucks or pump trucks. Wash water from concrete trucks will be washed out at a designated site.	At designated washout area near entrance of site
Solvents-colorless, blue, or yellow liquid-perchloroethylene, methylene chloride, trichloroethylene, petroleum distillates	Used by utility and painting contractors and will be removed from the site by contractors. No equipment cleaning allowed in project limits.	Stored at staging area. Can be found on BMP Map.
Paints-various color liquid-metal oxides, Stoddard solvent, talc, calcium carbonate, arsenic, petroleum distillates, copper, chromium	Used by painting contractor. Paints and stains may be stored inside the structure and the contractor will remove waste paints and stains from the site.	Staging area

Pollutants or Pollutant Constituents (that could be discharged if exposed to storm water)	Pollutant-Generating Activity	Location on Site (or reference SWPPP site map where this is shown)
Sanitary Waste Management-bacteria, parasites, viruses	Fecal coli form bacteria may occur in surrounding waters as a result of the overflow of domestic sewage or non-point sources of human and animal waste that could impact the river or other water sources. Portable toilets will be contained on the site in designated areas. Licensed sanitary services will ensure facilities are in working order at all times.	Near Portable toilets
Fertilizers-liquid/solid grains-Nitrogen, phosphorous	Fertilizer is seldom used during final site preparation when vegetated areas are sodded or seeded. Fertilizer will not be applied just before a storm event, and will not be stored on the site for any length of time.	Throughout landscaped area

4.2 Non-Storm Water Discharges

Check allowable non-storm water discharges that are present and describe the measures used to reduce them or prevent them from contributing pollutants to discharges:

Authorized Non-Storm Water Discharges	Present	Comments/Controls
Discharges from emergency fire-fighting activities	<input checked="" type="checkbox"/> Y <input type="checkbox"/> N	
Fire hydrant flushing	<input checked="" type="checkbox"/> Y <input type="checkbox"/> N	Discharge in correct location ensuring no contamination takes place.
Properly managed landscape irrigation (excludes fertilizer injector systems)	<input type="checkbox"/> Y <input checked="" type="checkbox"/> N	N/A
Properly managed vehicle and equipment wash water with no soaps, solvents, or detergents	<input type="checkbox"/> Y <input checked="" type="checkbox"/> N	
Water used to control dust	<input checked="" type="checkbox"/> Y <input type="checkbox"/> N	Water Truck
Drinking water, includes uncontaminated water line flushing	<input type="checkbox"/> Y <input checked="" type="checkbox"/> N	N/A
External building washdown with no soaps, solvents, detergents, or hazardous substances	<input type="checkbox"/> Y <input checked="" type="checkbox"/> N	N/A

4.3 Dewatering Practices

Check box if section not applicable to this site

4.4 Natural Buffers or Equivalent Sediment Controls

Buffer Compliance Alternatives

Are there any surface waters within 50 feet of your project's earth disturbances?

YES NO

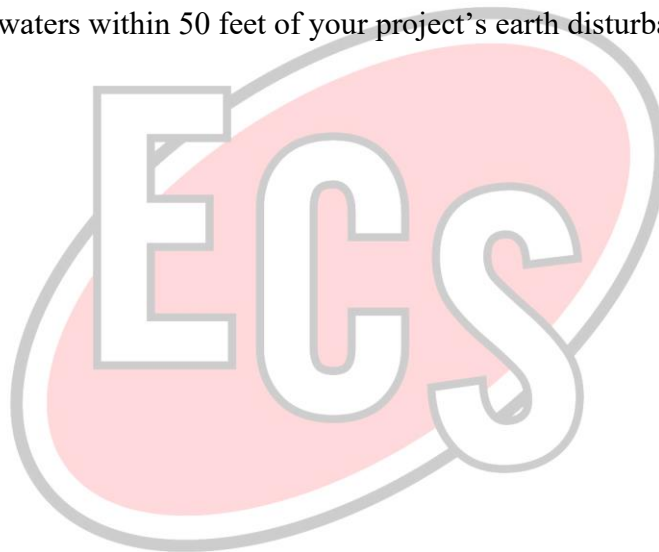

SECTION 5: EROSION AND SEDIMENT CONTROLS – BMPS

5.1 List of Erosion and Sediment BMPs on Site



CGP Requirement	Example BMPs	EPA SWPPP Guide Section	BMPs Selected (Name and Reference Number if applicable)
Preserve vegetation where possible and direct storm water to vegetated areas when feasible (CGP 2.2.2.)	Phasing to minimize disturbance, signs/fences to protect areas not being disturbed.	Chapter 4, ESC Principle 1	Phasing, and area of disturbance limited as shown on BMP map.
Install sediment controls along perimeter areas that receive pollutant discharges (CGP 2.2.3.).	Silt fence, fiber rolls, earth berms	Chapter 4, ESC Principle 7	Silt fence being used around three out of four sides of site. See BMP Map.
Minimize sediment track-out (CGP 2.2.4.)	Restrict access, stabilize exits, track-out pads, tire washing station, clean-up sediments	Chapter 4, ESC Principle 9	Track out pad being used as shown on BMP map.
Manage stockpiles with perimeter controls and locate away from storm water conveyances (CGP 2.2.5.)	Sediment barriers downgradient, proper location, covered stockpiles, diverting storm water from stockpiles	Chapter 4, ESC Principle 4	To be held in staging area with earth berm border.
Minimize dust (CGP 2.2.6.)	Water application, mulching, chemical dust suppression techniques		Water Truck
Minimize steep slope disturbance (CGP 2.2.7.)	Erosion control blankets, tackifiers, protect slopes from disturbance	Chapter 4, ESC Principle 5	Avoiding sloped areas and seeding within 14 calendar days where disturbance has ended.
Preserve topsoil (CGP 2.2.8.)	Stockpile topsoil	Chapter 4, ESC Principle 1	Stockpiling Topsoil that has been stripped for later use. Reducing height of stockpiles.
Minimize soil compaction where final cover is vegetation (CGP 2.2.9.)	Restrict vehicle access, recondition soils before seeding		Limited disturbance area. Restricted vehicle access. Reseeding within 14 calendar days where disturbance has been completed.
Protect storm drain inlets (CGP 2.2.10.)	Inserts, rock-filled bags, covers	Chapter 4, ESC Principle 6	N/A

Slow down runoff with erosion controls and velocity dissipation devices (CGP 2.2.11.)	Check dams, riprap	Chapter 4, ESC Principle 3	N/A
Appropriately design any sediment basins or impoundments (CGP 2.2.12.)	Design to 2-year 24-hour storm or 3,600 cubic feet per acre drained, include design specifications	Chapter 4, ESC Principle 8	N/A
Follow requirements for any treatment chemicals (polymers, flocculants, coagulants, etc.)	Store in leak proof containers and cover, proper training, minimize use		N/A
Stabilize exposed portions of site with 14 days of inactivity (CGP 2.2.14).	Seeding, erosion control blankets, gravel, hydromulch	Chapter 9	Seeding within 14 calendar days of inactivity

5.1.1: [Silt Fence / Appendix H](#)

BMP Description/Instructions: Installed along perimeter of site to contain sediment.

<i>Installation Schedule:</i>	<i>Before construction</i>
<i>Maintenance and Inspection:</i>	<i>Inspect immediately after rainfall and at least daily during prolonged rainfall. Look for runoff bypassing ends and barriers or undercutting barriers. Repair or replace damaged areas of the barrier and remove accumulated sediment. To be inspected during scheduled inspections Remove accumulated sediment when it reaches 1/2 the height of the fence.</i>
<i>Responsible Staff:</i>	<i>Operator</i>
<i>Design Specifications and Drawings:</i>	<i>Appendix H</i>

5.1.2: [Stabilized Construction Entrance / Appendix H](#)

BMP Description/Instructions: a stabilized pad of crushed stone located where construction traffic exits site. Completed with Swale to sedimentation basin and Filter fabric layer below gravel.

<i>Installation Schedule:</i>	<i>Before Construction</i>
--------------------------------------	-----------------------------------

Maintenance and Inspection:	<i>Inspect daily for loss of gravel or sediment build up.</i>
Responsible Staff:	<i>Operator</i>
Design Specifications and Drawings:	<i>Appendix H</i>

5.1.4: [Water Truck / Appendix H](#)

BMP Description/Instructions: *During Construction especially during windy periods.*

Installation Schedule:	N/a
Maintenance and Inspection:	It will be determined on an as needed basis when water is needed to inhibit the creation of dust.
Responsible Staff:	Operator
Design Specifications and Drawings:	<i>Appendix H</i>

5.1.5: [Temporary Basin Outlet Protection](#)

BMP Description/Instructions: *Prevents Scour at Conveyance outlets and minimizes the potential for downstream erosion by reducing the velocity of concentrated stormwater flows. See Catchment calculations on grading and drainage map. See BMP Detail for more info.*

Installation Schedule:	<i>As soon as the pond is relocated</i>
Maintenance and Inspection:	Inspect and repair as needed. Add rock as needed to maintain the intended function.
Responsible Staff:	<i>Operator</i>
Design Specifications and Drawings:	<i>Appendix H</i>

5.2 Linear Site Perimeter Control Exemption

Check box if section not applicable to this site

If the site is linear and perimeter controls are not feasible, describe other practices in use:
N/A

5.3 Final Stabilization

Description of final stabilization practices and schedule:

Type of stabilization (vegetation/landscaped, graveled, paved, etc.)	Location	Implementation Schedule
Constructed Buildings / Impervious Surface	Throughout site	Phase IV- Vertical Construction
Asphalt/Pavement	Throughout site	Phase III- Utilities
Landscaping	Throughout site	In phases as disturbance completion in each area. Seeding to be completed within 14 calendar days of inactivity. Final landscaping complete to stabilize site in Phase V

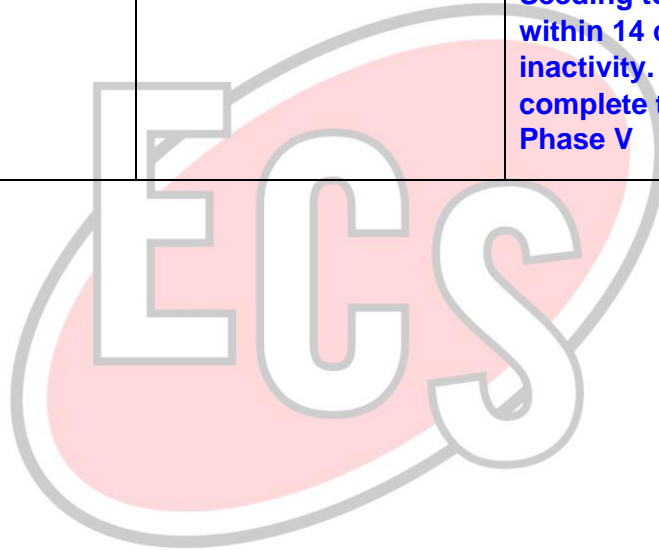

SECTION 6: BMPS - POLLUTION PREVENTION/OPERATIONAL CONTROLS

6.1 *Spill Prevention and Response*

Describe spill procedures and materials available for expeditious containment, clean-up and disposal of spills:

- 1st Priority: Protect all people
- 2nd Priority: Protect equipment and property
- 3rd Priority: Protect the environment

1. Make sure the spill area is safe to enter and that it does not pose an immediate threat to health or safety of any person.
2. Stop the spill source.
3. Check for hazards (flammable material, noxious fumes, cause of spill) – if flammable liquid, turn off engines and nearby electrical equipment. If serious hazards are present leave area and call 911. **LARGE SPILLS ARE LIKELY TO PRESENT A HAZARD.**
4. Call co-workers and supervisor for assistance and to make them aware of the spill and potential dangers.
5. If possible, stop spill from entering drains (use absorbent or other material as necessary).
6. Stop spill from spreading (use absorbent or other material).
7. If spilled material has entered a storm sewer; contact the City Storm Water Department.
8. Clean up spilled material according to manufacturer specifications, for liquid spills use absorbent materials and do not flush area with water.
9. Properly dispose of cleaning

Identify the employee responsible for detection and response of spills and leaks:

[Johnathan Barlow 970-779-2042 \(Project Manager/Superintendent\)](#)

Any discharges in 24 hours equal to or in excess of the reportable quantities listed in 40 CFR 117, 40 CFR 110, and 40 CFR 302 will be reported to the National Response Center and the Division of Water Quality (DWQ) as soon as practical after knowledge of the spill is known to the permittees. The permittee shall submit within 14 calendar days of knowledge of the release a written description of: the release (including the type and estimate of the amount of material released), the date that such release occurred, the circumstances leading to the release, and measures taken and/or planned to be taken to the Division of Water Quality (DWQ), 288 North 1460 West, P.O. Box 144870, Salt Lake City, Utah 84114-4870. The Storm Water Pollution Prevention Plan must be modified within 14 calendar days of knowledge of the release to provide a description of the release, the circumstances leading to the release, and the date of the release. In addition, the plan must be reviewed to identify measures to prevent the reoccurrence of such releases and to respond to such releases, and the plan must be modified where appropriate.

Agency	Phone Number
National Response Center	(800) 424-8802
Division of Water Quality (DWQ) 24-Hr Reporting	(801)-231-1769 (801) 536-4123
Utah Department of Health Emergency Response	(801) 580-6681
Weber County IDDE Hotline	(801) 399-8374
Plain City Fire Department	(801) 731-1110

Material	Media Released To	Reportable Quantity
Engine oil, fuel, hydraulic & brake fluid	Land	25 gallons
Paints, solvents, thinners	Land	100 lbs (13 gallons)
Engine oil, fuel, hydraulic & brake fluid	Water	Visible Sheen
Antifreeze, battery acid, gasoline, engine degreasers	Air, Land, Water	100 lbs (13 gallons)
Refrigerant	Air	1 lb

6.2 Pollution Prevention Controls

CGP Requirements	Example BMPs	EPA SWPPP Guide Section	BMPs Selected (Name and Reference Number if applicable)
Equipment and vehicle fueling (CGP 2.3.1)	Spill kits, SPCCP, drip pans, locate activities away from conveyances, use secondary containment	Chapter 5, P2 Principle 4	N/A
Equipment and vehicle washing (CGP 2.3.2.)	Locating away from surface waters and storm water conveyances, directing wash waters to a sediment basin or sediment trap, using filtration devices	Chapter 5, P2 Principle 5	N/A
Storage, handling, and disposal of building	Cover (plastic sheeting / temporary roofs), secondary	Chapter 5, P2 Principle 1 and 2	Staging area with material storage, Construction

products and waste (CGP 2.3.3.)	containment, leakproof containers, proper dumpsters, secured portable toilets, locate away from storm water conveyances		dumpster, Portable toilets, spill kit, and concrete washout.
Washing of stucco, paint, concrete, form release oils, curing compounds, etc. (CGP 2.3.4.)	Leak proof containers, lined pits, locate away from storm water conveyances	Chapter 5, P2 Principle 3	Concrete washout with lined basin and berms to contain.
Properly apply fertilizer (CGP 2.3.5)	Follow manufacture specifications, document deviations in applications, avoid applications to frozen ground, before heavy rains, or to storm water conveyances		Avoiding application prior to heavy rains or storm events.

6.2.1.: [Waste Disposal \(Dumpster\)](#)

BMP Description/Instructions: Controlled storage and disposal of solid waste. Dumpster or similar control will be on site to collect garbage, ensure that all personnel use it properly, dispose of toxic and hazardous materials properly, and arrange for periodic disposal of collected waste at an authorized disposal location.

Installation Schedule:	Phase I- Grading
Maintenance and Inspection:	On-site personnel are responsible for correct disposal of waste. Collect site trash daily and deposit in covered containers
Responsible Staff:	Operator
Design Specifications and Drawings:	Appendix H

6.2.2.: [Spill Kit](#)

BMP Description/Instructions: A 25 Gallon spill kit will be located near the entrance or job trailer with identifying sign.

Installation Schedule:	Beginning of project
Maintenance and Inspection:	Weekly check to make sure spill kit is present and unused. If spill kit has been used it needs to be replaced.
Responsible Staff:	Operator
Design Specifications and Drawings:	

6.2.3.: **Concrete Washout**

BMP Description/Instructions: Perform washout of concrete trucks on designated areas; Do not washout concrete trucks into storm drains, open ditches, streets or streams; Intercept any concrete slurry from concrete cutting activities on the streets. Designate a wash out area on a long, flat, shallow area, or use a concrete washout pan, train employees and subcontractors.

Installation Schedule:	Before actives described activities begin.
Maintenance and Inspection:	Inspect subcontractors to ensure that concrete wastes are being properly managed.
Responsible Staff:	Operator
Design Specifications and Drawings:	<i>To have Containment earth berm all around</i>

6.2.3.: **Portable Toilets**

BMP Description/Instructions: Temporary on-site facilities for construction personnel.

Installation Schedule:	Phase I Grading (Will need on site on day one). Must be placed on a pervious surface at least 10' away from any hard surface draining to a storm drain.
Maintenance and Inspection:	Inspect for compliance to location continual service by licensed provider. Weekly maintenance schedule or as needed.
Responsible Staff:	Operator
Design Specifications and Drawings:	<i>To have Containment earth berm all around</i>

SECTION 7: SPECIAL CONDITIONS

7.1 Emergency Related Projects

Emergency-Related Project? Yes No

7.2 UIC Class 5 Injection Wells

Check box if section not applicable to this site

|

7.3 Chemical Treatment

Check box if section not applicable to this site

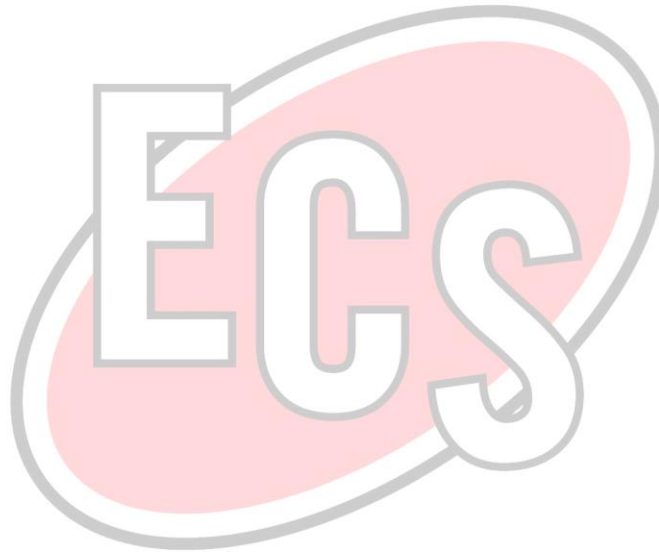

SECTION 8: INSPECTIONS & CORRECTIVE ACTIONS

8.1 Inspections

Minimum Inspection Schedule Requirements:

Standard Frequency:
<input type="checkbox"/> Once every 7 calendar days.
<input checked="" type="checkbox"/> Once every 14 calendar days and within 24 hours of the end of a storm event of 0.5 inches or greater. Rain gauge/weather station used: ComplianceGo
Increased Frequency (if applicable):
<input type="checkbox"/> <i>Sites discharging to impaired or high quality waters:</i> Once every 7 calendar days and within 24 hours of the end of a storm event of 0.5 inches or greater.
Decreased Frequency (if applicable):
<input type="checkbox"/> <i>Arid areas:</i> once a month and within 24 hours of a 0.5 inch storm event or greater.
<input type="checkbox"/> <i>Semi-arid areas:</i> once a month and within 24 hours of a 0.5 inch storm event or greater during the dry season: May-October (also select the inspection schedule followed outside of the dry season).
<input type="checkbox"/> <i>Frozen conditions with work suspended – must have 3 months of continuous expected frozen conditions based on historical averages:</i> no inspections November-April (also select the inspection schedule followed when not frozen)
<input type="checkbox"/> <i>Frozen conditions with continued activities - must have 3 months of continuous expected frozen conditions based on historical averages:</i> once per month November-April (also select the inspection schedule followed when not frozen)
Other:
<input type="checkbox"/> Describe alternative frequency: To meet minimum requirements

Inspection Reports are filed in Appendix C

****All Inspection cancellations must be done via email****

8.2 Corrective Actions

Correction Action Report is filed in Appendix D.

8.3 Delegation of Authority

See the signed delegation of authority forms in Appendix E.

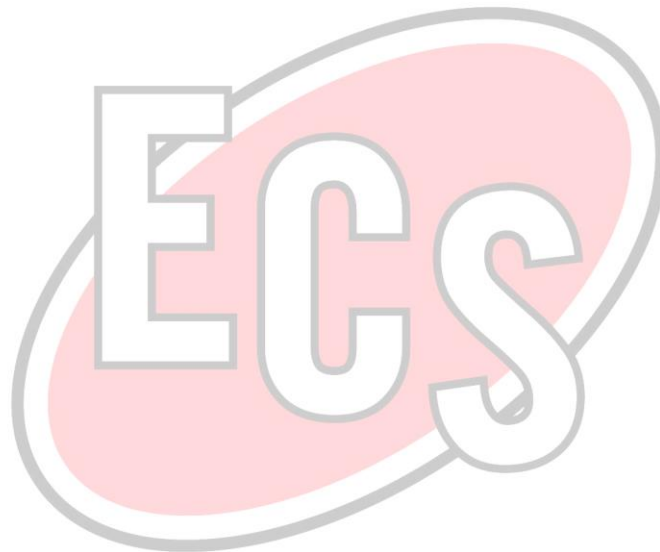

SECTION 9: RECORDKEEPING

9.1 *Recordkeeping*

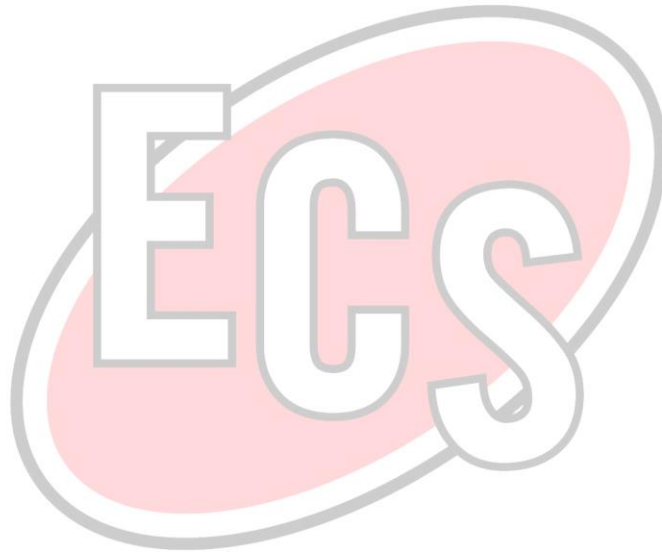

9.2 Log of Changes to the SWPPP

Description of the Amendment	Date of Amendment	Amendment Prepared by [Name(s) and Title]

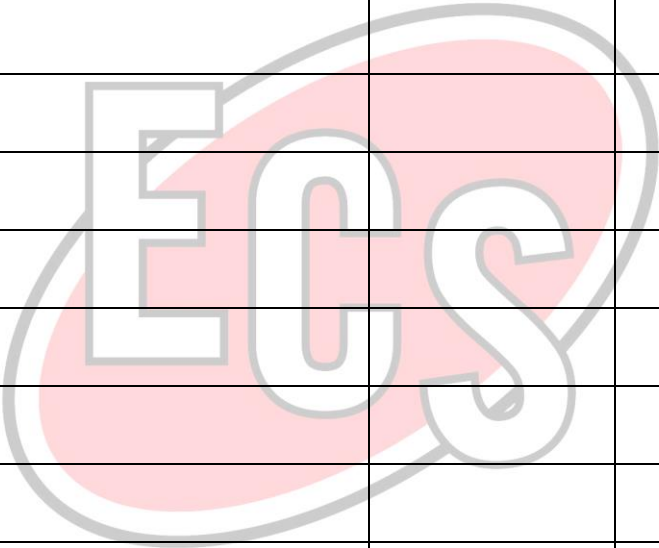

SECTION 10: CERTIFICATION

Owner

I certify under penalty of law that this document and all attachments were prepared under my direction or supervision in accordance with a system designed to assure that qualified personnel properly gathered and evaluated the information submitted. Based on my inquiry of the person or persons who manage the system, or those persons directly responsible for gathering the information, the information submitted is, to the best of my knowledge and belief, true, accurate, and complete. I am aware that there are significant penalties for submitting false information, including the possibility of fine and imprisonment for knowing violations.

Name: Chadwick Spencer

Title: Manager

Signature:



Date: 10/19/22

General Contractor

I certify under penalty of law that this document and all attachments were prepared under my direction or supervision in accordance with a system designed to assure that qualified personnel properly gathered and evaluated the information submitted. Based on my inquiry of the person or persons who manage the system, or those persons directly responsible for gathering the information, the information submitted is, to the best of my knowledge and belief, true, accurate, and complete. I am aware that there are significant penalties for submitting false information, including the possibility of fine and imprisonment for knowing violations.

Name: Johnathan Barlow

Title: Project Manager

Signature:

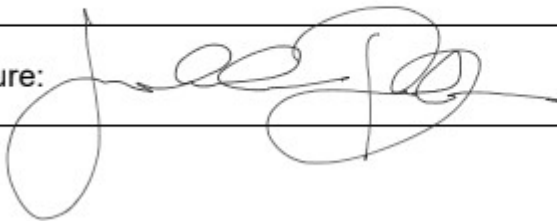

Date: 10-19-22

SWPPP APPENDICES

Attach the following documentation to the SWPPP:

Appendix A – Site Maps

Appendix B – NOI

Appendix C – Inspection Reports

Appendix D – Corrective Action Report

Appendix E – Subcontractor

***Certifications/Agreements/Delegation of
Authority (see CGP 9.16(1)b.)***

Appendix F – Training Logs and Certifications (see CGP 6)

***Appendix G – Additional Information (i.e., Other permits such as
dewatering, stream alteration, wetland; and out of
date swppp documents)***

Appendix H – BMP Instruction and Detail Specifications

Appendix I – Construction General Permit

Appendix A: Site Maps

Include any site maps in this appendix. For site map requirements review SWPPP section 2.5.

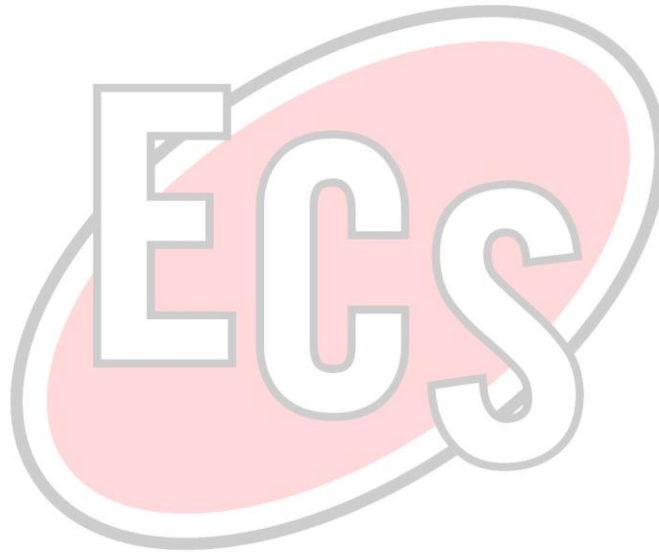



9350 W

9300 W

9300 W

W 900 S

200.00 ft

400.00 ft

600.00 ft

800.00 ft

1,000.00 ft

1,200.00 ft

2,200.00 ft

2,000.00 ft

1,800.00 ft

1,600.00 ft

1,400.00 ft

2,674.99 ft

2,400.00 ft

W 900 S

W 900 S

W 900 S

W 900 S

The Armstrong Compound

Silverline Finishing Inc



BENCHMARK	
NORTH QUARTER CORNER OF SECTION 20, TOWNSHIP 6 NORTH, RANGE 3 WEST SALT LAKE BASE AND MERIDIAN	
ELEV = 4220.00'	

REVISION SCHEDULE			
NUMBER	DATE	AUTHOR	COMPANY REPRESENTATIVE SIGNATURE
1			
2			
3			
4			
5			
6			
7			
8			
9			
10			
11			
12			

- SCOPE OF WORK:**
 PROVIDE, INSTALL AND/OR CONSTRUCT THE FOLLOWING PER THE SPECIFICATIONS GIVEN OR REFERENCED, THE DETAILS NOTED, AND/OR AS SHOWN ON THE CONSTRUCTION DRAWINGS:
- 1 VEHICLE WASHDOWN AND STABILIZED CONSTRUCTION ENTRANCE PER DETAIL 1/C-400.
 - 2 SUGGESTED TEMPORARY CONSTRUCTION SITE PARKING, STAGING, DUMPSTER, AND MATERIAL STORAGE AREA.
 - 3 CONCRETE CLEANOUT LINED BASIN OR DUMPSTER
 - 4 LIMITS OF DISTURBANCE
 - 5 INSTALL TEMPORARY SILT FENCE PER DETAIL 4/C-400
 - 6 INSTALL TEMPORARY OUTLET PROTECTION PER DETAIL 5/C-400

- GENERAL NOTES**
1. THIS PLAN IS DESIGNED AS A FIRST APPRAISAL OF NECESSARY MEANS TO PROTECT THE WATERS OF THE STATE FROM POTENTIAL POLLUTION. IT IS THE RESPONSIBILITY OF THE OWNER/OPERATOR TO ADD WARRANTED BEST MANAGEMENT PRACTICES (BMP'S) AS NECESSARY. MODIFY THOSE SHOWN AS APPROPRIATE, AND DELETE FROM THE PROJECT THOSE FOUND TO BE UNNECESSARY. FEDERAL AND STATE LAW ALLOWS THESE UPDATES TO BE MADE BY THE OWNER/OPERATOR ONSITE AND RECORDED BY THE OWNER/OPERATOR ON THE COPY OF THE SWPPP KEPT ONSITE.
 2. DISTURBED LAND SHALL BE KEPT TO A MINIMUM. STABILIZATION MEASURES SHALL BE INITIATED AS SOON AS PRACTICABLE IN PORTIONS OF THE SITE WHERE CONSTRUCTION ACTIVITIES HAVE TEMPORARILY OR PERMANENTLY CEASED, BUT IN NO CASE MORE THAN 14 DAYS AFTER THE CONSTRUCTION ACTIVITY IN THAT PORTION OF THE SITE HAS TEMPORARILY OR PERMANENTLY CEASED. HOWEVER, WHERE CONSTRUCTION ACTIVITY ON A PORTION OF THE SITE IS TEMPORARILY CEASED, AND EARTH DISTURBING ACTIVITIES WILL BE RESUMED WITHIN 21 DAYS, TEMPORARY STABILIZATION MEASURES DO NOT HAVE TO BE INITIATED ON THAT PORTION OF THE SITE.
 3. RESEED DISTURBED LAND WITH NATIVE GRASS MIXTURE WITHIN 14 CALENDAR DAYS OF ACHIEVEMENT OF FINISH GRADE TO STABILIZE SOILS IF LAND IS NOT TO BE RE-WORKED WITHIN 14 CALENDAR DAYS OF THE CESSATION OF CONSTRUCTION ACTIVITIES AT THAT LOCATION.
 4. DETAILS SHOWN ARE TO BE EMPLOYED TO PROTECT RUNOFF AS APPROPRIATE DURING CONSTRUCTION. NOT ALL DETAILS ARE NECESSARY AT ALL PHASES OF THE PROJECT. IT SHALL BE THE RESPONSIBILITY OF THE OWNER/OPERATOR TO USE APPROPRIATE BEST MANAGEMENT PRACTICES AT THE APPROPRIATE PHASE OF CONSTRUCTION. SEE SWPPP FOR BMP IMPLEMENTATION SCHEDULE.
 5. VARIOUS BEST MANAGEMENT PRACTICES HAVE BEEN SHOWN ON THE PLANS AT SUGGESTED LOCATIONS. THE CONTRACTOR MAY MOVE AND RECONFIGURE THESE BMP'S TO OTHER LOCATIONS IF PREFERRED, PROVIDED THE INTENT OF THE DESIGN IS PRESERVED.
 6. NOT ALL POSSIBLE BMP'S HAVE BEEN SHOWN. THE CONTRACTOR IS RESPONSIBLE TO APPLY CORRECT MEASURES TO PREVENT THE POLLUTION OF STORM WATER PER PROJECT SWPPP.
 7. A UPDES (UTAH POLLUTANT DISCHARGE ELIMINATION SYSTEM) PERMIT IS REQUIRED FOR ALL CONSTRUCTION ACTIVITIES 1 ACRE OR MORE.

LAYTON
 919 North 400 West
 Layton, UT 84041
 Phone: 801.547.1100

SALT LAKE CITY
 Phone: 801.255.0529

TOOELE
 Phone: 435.843.3590

CEDAR CITY
 Phone: 435.865.1453

RICHFIELD
 Phone: 435.896.2983

WWW.ENSIGNENG.COM

FOR:
 KHR HOLDINGS, LLC
 8486 STATE STREET
 MIDVALE, UTAH 84047

CONTACT:
 RYAN BROWN
 PHONE: 801-514-6406

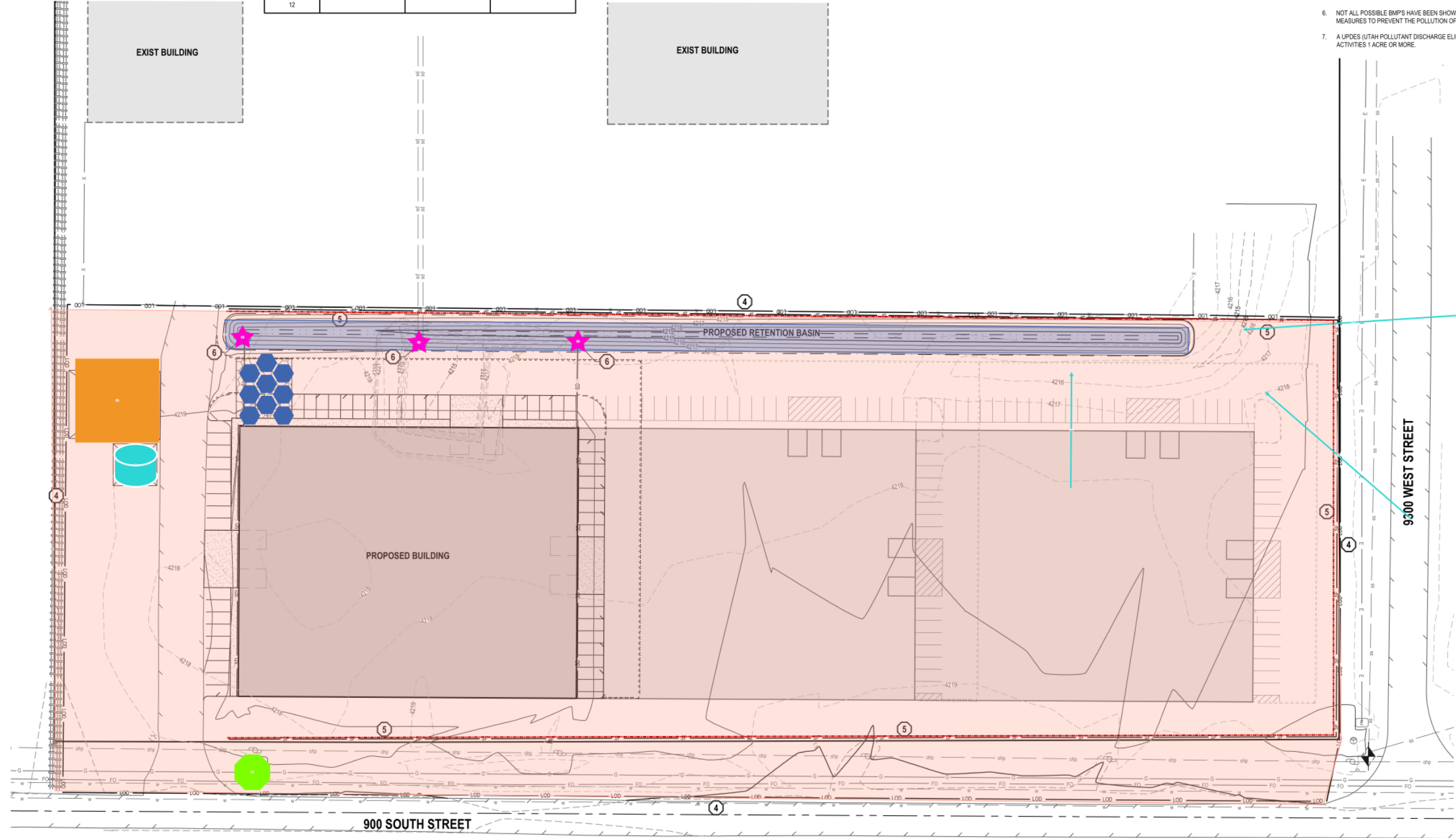

KHR SITE DEVELOPMENT

9350 WEST 791 SOUTH
 WEST WEBER COUNTY, UTAH



NO.	DATE	REVISION	BY
1		FOR REVIEW	
2			
3			
4			
5			
6			
7			
8			







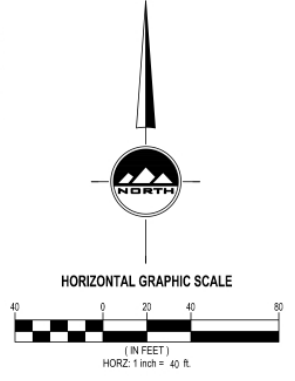

EROSION CONTROL PLAN

PROJECT NUMBER 11590	PRINT DATE 8/2/22
DRAWN BY J.MOISS	CHECKED BY I.BUCKLEY
PROJECT MANAGER C.PRESTON	

C-300





-  Area of Disturbance (1)
-  Retention Basin (1)
-  Water Flow (3)
-  Silt Fence (1)
-  Temporary Basin Outlet Protection (3)
-  Concrete Cleanout Lined Basin or Dumpster (1)
-  Site Parking, Staging, Dumpster, Portable Toilets, and Material Storage (1)
-  Track Out Pad/Vehicle Washdown (1)
-  SWPPP Sign (1)

Search

Map Unit Legend

Davis-Weber Area, Utah (UT607)

Davis-Weber Area, Utah (UT607)

Map Unit Symbol	Map Unit Name	Acres in AOI	Percent of AOI
WhA	Warm Springs fine sandy loam, saline, sodic, 0 to 1 percent slopes, channeled	8.6	100.0%
Totals for Area of Interest		8.6	100.0%

Soil Map

Scale (not to scale)



Appendix B: NOI

Include a copy of your NOI in this appendix. The NOI must be signed.

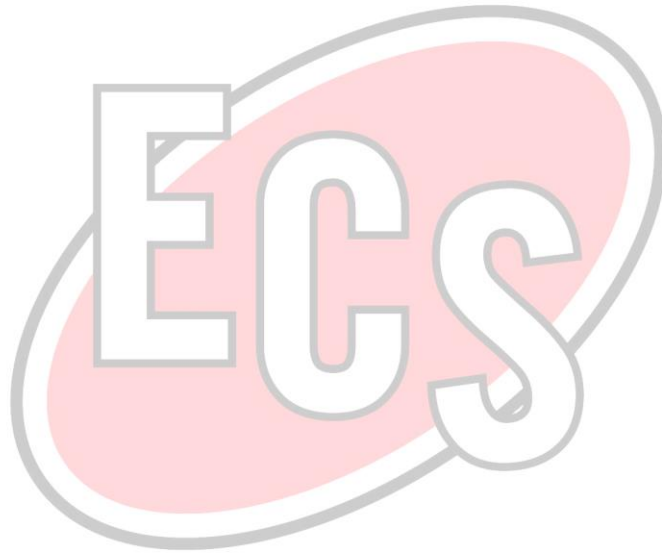



Notice of Intent (NOI) for Storm Water Discharges Associated with Construction
Activity Under the Construction General Permit (CGP) UPDES General Permit
No. UTRC00000

NOI

Permit Information

Master Permit Number: UTRC00000

UPDES ID: UTRC06043

State/Territory to which your project/site is discharging: UT

Is your project/site located on federally recognized Indian Country Lands? No

Which type of form would you like to submit? Notice of Intent (NOI)

Have stormwater discharges from your project/site been covered previously under an UPDES permit? No

Has a Stormwater Pollution Prevention Plan (SWPPP) been prepared in advance of filling this NOI, as required? Yes

Owner/Operator Information

Owner Information

Owner: KHR Holdings, LLC

Status of Owner: Private

Owner Mailing Address:

Address Line 1: 8488 State Street

Address Line 2:

City: Midvale

ZIP/Postal Code: 84047

State: UT

Owner Point of Contact Information

First Name Middle Initial Last Name: Chadwick . Spencer

Title: Owner

Phone: 801-514-6406

Ext.:

Email: Chad@Aeroscapeutah.com

Operator Information

Is the Operator Information the same as the Owner Information? No

Operator: Silverbrook Construction

Operator Mailing Address:

Address Line 1: PO Box 423

Address Line 2:

City: Fillmore

ZIP/Postal Code: 84631

State: UT

Operator Point of Contact Information

First Name Middle Initial Last Name: Johnathan . Barlow

Title: Contractor

Phone: 970-779-2042

Ext.:

Email: johnb@Silverbrook.us

NOI Preparer Information

This NOI is being prepared by someone other than the certifier.

First Name Middle Initial Last Name: Jaimes . Haynes

Organization: Erosion Control Services

Phone: 801-302-3021

Ext.:

Email: office@erosioncontrolservices.net

Project/Site Information

Project/Site Name: KHR Holdings

Project Number:

Project/Site Address

Address Line 1: 9350 West 791 South

Address Line 2:

City: West Weber

ZIP/Postal Code: 84404

State: UT

County or Similar Division: Weber

Have you submitted a Fugitive Dust Control Plan to UT Division of Air Quality? Yes

Latitude/Longitude for the Project/Site

Coordinate System: Decimal Degrees

Latitude/Longitude: 41.252027°N, 112.206839°W

Estimated Project Start Date: 10/26/2022

Estimated Project End Date: 04/02/2023

Total Area of Plot (in Acres): 9.65

Estimated Area to be Disturbed (in Acres): 6.9

Proposed Best Management Practices

Silt Fence/Straw Wattle/Perimeter Controls

Sediment Pond

Seeding/Preservation of Vegetation

Structural Controls (Berms, Ditches, etc.)

Proposed Good Housekeeping Practices

Sanitary/Portable Toilet

Washout Areas

Construction Chemicals/Building Supplies Storage Area

Garbage/Waste Disposal

Non-Storm Water

Track Out Controls

Spill Control Measures

Site Construction Types

Commercial

Site Activity Information ▼

Municipal Separate Storm Sewer System (MS4) Operator Name: Weber County (Unincorporated Areas)

Receiving Water Body: Weber river

➤ This is a guess

What is the estimated distance to the nearest water body? 2519

Unit: Feet

Is the receiving water designated as impaired? No

Will any part of the project area be located within 50 feet of any Water of the State? No

Does this project site have any other UPDES permits? No

Subdivision Information ▼

Is this project involved in the development of a subdivision? No

Certification Information ▼

I certify under penalty of law that this document and all attachments were prepared under my direction or supervision in accordance with a system designed to assure that qualified personnel properly gathered and evaluated the information submitted. Based on my inquiry of the person or persons who manage the system, or those persons directly responsible for gathering the information, the information submitted is, to the best of my knowledge and belief, true, accurate, and complete. I have no personal knowledge that the information submitted is other than true, accurate, and complete. I am aware that there are significant penalties for submitting false information, including the possibility of fine and imprisonment for knowing violations. Signing an electronic document on behalf of another person is subject to criminal, civil, administrative, or other lawful action.

Certified By: Johnathan M. Barlow

Certifier Title: Project Manager

Certifier Email: johnb@silverbrook.us

Certified On: 11/07/2022 4:21 PM ET

Appendix C: Inspection Reports

Place all completed inspection reports in this appendix. You may also put blank inspection reports here to be completed.

You are encouraged to create your own inspection forms for each site. Inspection reports must have the following information:

- 1) The inspection date.
- 2) The UPDES ID number (UTRC06043).
- 3) Name and title of personnel making the inspections.
- 4) Summary of inspection findings and any necessary corrective actions:
 - a. Are storm water controls properly installed and operational? If failed then why?
 - b. Presence of any conditions that could lead to spills or leaks.
 - c. Locations where new or modified controls are necessary.
 - d. Signs of visible erosion or sediment depositing related to your discharges.
 - e. Any incidents of noncompliance.
 - f. Visual quality of any discharges occurring.
- 5) Rainfall amount if the inspection was triggered by a precipitation event.
- 6) If it was unsafe to inspect any areas of the site, a description of the area and reason.

Appendix D: Corrective Action Report

An example corrective action report has been included in this appendix. Review SWPPP section 8.2 for corrective action requirements. You can also create your own form or include corrective actions on your inspection form.

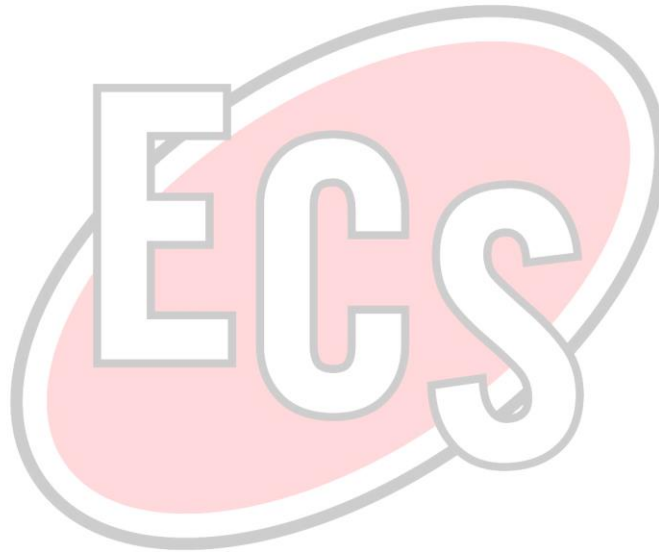

Appendix D – Corrective Action Report

Inspection Date	Inspector Name(s)	Description of BMP Deficiency	Corrective Action Needed (including planned date/responsible person)	Date Action Taken/Responsible person

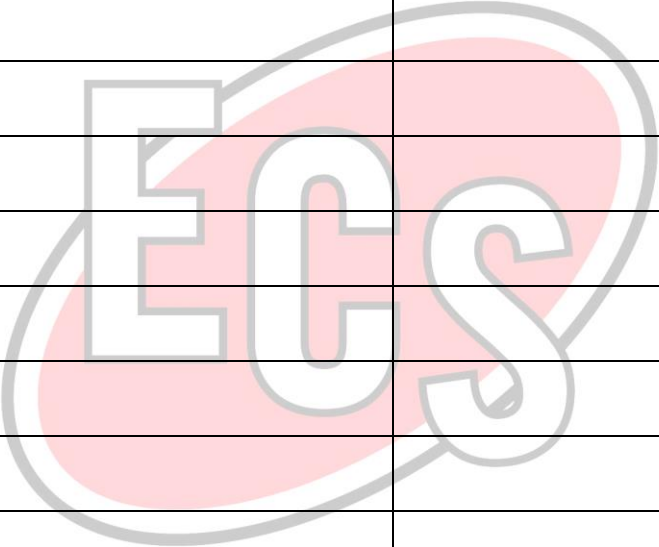

Appendix E: Subcontractor Certifications/Agreements/Delegation of Authority (CGP 9.16.(1)b.)

A sample subcontractor agreement form and delegation of authority form have been included in this appendix. If these are used, keep complete signed forms here.

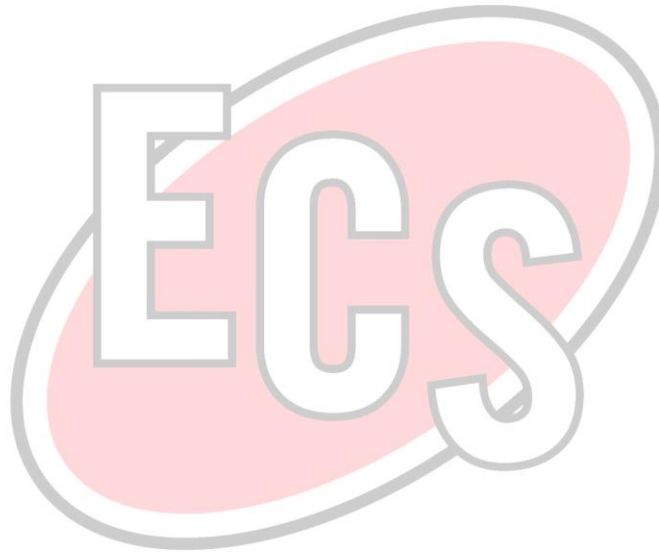

SUBCONTRACTOR CERTIFICATION
STORM WATER POLLUTION PREVENTION PLAN

Project Number: _____

Project Title: _____

Operator(s): _____

As a subcontractor, you are required to comply with the Storm water Pollution Prevention Plan (SWPPP) for any work that you perform on-site. Any person or group who violates any condition of the SWPPP may be subject to substantial penalties or loss of contract. You are encouraged to advise each of your employees working on this project of the requirements of the SWPPP. A copy of the SWPPP is available for your review at request.

Each subcontractor engaged in activities at the construction site that could impact storm water must be identified and sign the following certification statement:

I certify under the penalty of law that I have read and understand the terms and conditions of the SWPPP for the above designated project and agree to follow the BMPs and practices described in the SWPPP.

This certification is hereby signed in reference to the above named project:

Company: _____

Address: _____

Telephone Number: _____

Type of construction service to be provided: _____

Signature: _____

Title: _____

Date: _____

Delegation of Authority

I, Chadwick Spencer, hereby designate the person or specifically described position below to be a duly authorized representative for the purpose of overseeing compliance with environmental requirements, including the UPDES "General Permit for Storm Water Discharges Associated with Construction Activity" (CGP), at the construction site:

KHR Holdings, Permit No. UTR _____

The designee is authorized to sign all reports required by the Permit and other information requested by the Director of the Utah Division of Water Quality, or by an authorized representative of the Executive Secretary.

KHR Holdings, LLC
8488 State Street
Midvale UT 84047

By signing this authorization, I confirm that I meet the requirements to make such a designation as set forth in Part 9.16 of the CGP, and that the designee above meets the definition of a "duly authorized representative" as set forth in Part 9.16.b. of the CGP.

I certify under penalty of law that this document and all attachments were prepared under my direction or supervision in accordance with a system designed to assure that qualified personnel properly gather and evaluate the information submitted. Based on my inquiry of the person or persons who manage the system, or those persons directly responsible for gathering the information, the information submitted is, to the best of my knowledge and belief, true, accurate, and complete. I am aware that there are significant penalties for submitting false information, including the possibility of fine and imprisonment for knowing violations.

Owner Contact: Chadwick Spencer _____

Signature: Chadwick Spencer _____

Date: 10/19/22 _____

Delegation of Authority

I, Chadwick Spencer, hereby designate the person or specifically described position below to be a duly authorized representative for the purpose of overseeing compliance with environmental requirements, including the UPDES "General Permit for Storm Water Discharges Associated with Construction Activity" (CGP), at the construction site:

KHR Holdings, Permit No. UTR _____

The designee is authorized to sign all reports required by the Permit and other information requested by the Director of the Utah Division of Water Quality, or by an authorized representative of the Executive Secretary.

KHR Holdings, LLC
8488 State Street
Midvale UT 84047

By signing this authorization, I confirm that I meet the requirements to make such a designation as set forth in Part 9.16 of the CGP, and that the designee above meets the definition of a "duly authorized representative" as set forth in Part 9.16.b. of the CGP.

I certify under penalty of law that this document and all attachments were prepared under my direction or supervision in accordance with a system designed to assure that qualified personnel properly gather and evaluate the information submitted. Based on my inquiry of the person or persons who manage the system, or those persons directly responsible for gathering the information, the information submitted is, to the best of my knowledge and belief, true, accurate, and complete. I am aware that there are significant penalties for submitting false information, including the possibility of fine and imprisonment for knowing violations.

Owner Contact: _____

Signature: _____

Date: _____

Appendix F –SWPPP Training Log

Storm Water Pollution Prevention Training Log

Project Name:

Project Location:

Instructor's Name(s):

Instructor's Title(s):

Course Location: _____ Date: _____

Course Length (hours): _____

Storm Water Training Topic: *(check as appropriate)*

- Erosion Control BMPs
- Sediment Control BMPs
- Non-Storm Water BMPs
- Emergency Procedures
- Good Housekeeping BMPs

Specific Training Objective: _____

Attendee Roster: *(attach additional pages as necessary)*

No.	Name of Attendee	Company
1		
2		
3		
4		
5		
6		
7		
8		
9		
10		

Appendix G: Additional Information

Use this appendix for additional information such as other permits (dewatering, stream alteration, etc.) or out of date SWPPP documents.





Fugitive Dust Permit Completion

1 message

Customer Support <support@utahinteractive.org>
To: Erosion control Services <Office@erosioncontrolservices.net>

Wed, Oct 19, 2022 at 3:18 PM

Utah Department of **Environmental Quality**

195 North 1950 West
Salt Lake City, Utah 84114-4820
DAQ, Fugitive Dust Control Plan

Congratulations! Your Fugitive Dust Control Plan was successful.

1. Applicant Information

Name: Erosion control Services
Address: P.O. Box 1154, Salt Lake City, 84119
Phone: 801-302-3021
Email: Office@ErosionControlServices.Net
Applicant Type: Sub Contractor

2. Project Information

Project Name: KHR Holdings
Address: 9350 W 791 S, Ogden, 84404
County: Weber
Directions:
Acreage: 6.9
Latitude: 41.253054
Longitude: -112.206270

3. Point of Contact

Name: Jonathan Barlow
Company Name: Silverbrook Construction, Fillmore, 84631
Address: PO Box 423
Phone: 970-779-2042
Cell:

4. By submitting this plan I certified that:

- A. I am authorized, on behalf of the individual or company listed in Section 1, as Applicant, to apply for a Fugitive Dust Control Plan and to commit to all of the terms and conditions of the requested plan.
- B. Construction activities will be limited to lands that the applicant either owns or is authorized to use for construction activities.
- C. The applicant accepts responsibility for assuring that all contractors, subcontractors, and all other persons on the construction site covered by this plan, comply with the terms and conditions of the Fugitive Dust Control Plan.
- D. I understand that any false material statement, representation or certification made in this application may invalidate the plan or cause me to be subject to enforcement action pursuant to Utah Code Ann. 19-2-115.
- E. Failure to comply with fugitive dust rules may result in compliance action and penalties up to \$10,000 per violation/day.

Printed Name: Erosion control Services
Title: Sub Contractor
Company Name: Silverbrook Construction
Dust Plan Number: 563e7d60-0039-4524-bc71-19c8890c9852

FUGITIVE DUST CONTROL PLAN

GENERAL REQUIREMENT: ALL ACTIVITIES MUST MEET OPACITY REQUIREMENTS IN R307-309-5

THE FOLLOWING IS A LIST OF PROJECT ACTIVITIES AND BEST MANAGEMENT PRACTICES (BMP) THAT WILL BE CONDUCTED AT THIS SITE

BMP 03 CLEARING FOR SITE PREPARATION AND VACANT LAND CLEANUP.

Stabilize surface soils where support equipment and vehicles will operate.

03-01 Pre-water and maintain surface soils in a stabilized condition.

Stabilize disturbed soil immediately after clearing and grubbing activities.

03-03 Water disturbed soils to form crust.

Stabilize slopes at completion of activity.

03-06 Apply water and maintain sloping surfaces/wind breaks in a crusted condition.

BMP 05 CRUSHING OF CONSTRUCTION AND DEMOLITION DEBRIS, ROCK AND SOIL.

Stabilize surface soils where support equipment and vehicles will operate.

05-01 Pre-water and maintain surface soils in a stabilized condition.

Stabilize material before crushing.

05-04 Pre-water material.

Stabilize material during crushing.

05-06 Apply water to stabilize material so as to maintain compliance with opacity standards and permit conditions.

Monitor opacity.

05-07 Make adjustments to maintain compliance with opacity standards and permit conditions.

Stabilize material after crushing.

05-09 Water crushed material immediately following crushing.

05-12 Minimize height of stockpile.

Traffic.

05-13 Minimize vehicle miles.

05-14 Reduce truck traffic.

05-15 Reduce truck speed.

Transfer height.

05-16 Minimize transfer and drop point height.

BMP 06 CUT AND FILL SOILS FOR SITE GRADE PREPARATION.

Stabilize surface soils where support equipment and vehicles will operate.

06-01 Pre-water and maintain surface soils in a stabilized condition.

Pre-water soils.

06-03 Dig a test hole to depth of cut or equipment penetration to determine if soils are moist at depth. Continue to pre-water if not moist to depth of cut.

06-04 Apply water to depth of cut prior to subsequent cuts.

Stabilize soil during cut activities.

06-05 Water disturbed soils to maintain moisture.

BMP 09 DISTURBED SOIL THROUGHOUT PROJECT INCLUDING BETWEEN STRUCTURES.

Limit disturbance of soils where possible.

09-01 Limit disturbance of soils with the use of fencing, barriers, barricades, and/or wind barriers.

09-02 Limit vehicle mileage and reduce speed.

Stabilize and maintain stability of all disturbed soil throughout construction site.

09-03 Apply water to stabilize disturbed soils. Soil moisture must be maintained such that soils can be worked without generating fugitive dust.

BMP 11 HAULING MATERIALS.

Limit visible dust opacity from vehicular operations.

11-02 Limit vehicle mileage and speed.

Stabilize materials during transport on site.

11-04 Apply water prior to transport.

Clean wheels and undercarriage of haul trucks prior to leaving construction site.

11-05 Clean wheels.

11-06 Sweep or water haul road.

BMP 12 PAVING/SUBGRADE PREPARATION FOR PAVING STREETS, PARKING LOTS, ETC.

Stabilize adjacent disturbed soils following paving activities.

12-01 Apply and maintain water on disturbed soils.

12-03 Stabilize disturbed soils with vegetation or hydroseeding.

BMP 13 SAWING/CUTTING MATERIAL, CONCRETE, ASPHALT, BLOCK OR PIPE.

Limit visible emissions.

13-01 Use water control to dust.

BMP 14 SCREENING OF ROCK, SOIL OR CONSTRUCTION DEBRIS.

Stabilize surface soils where support equipment and vehicles will operate.

14-01 Pre-water and maintain surface soils in a stabilized condition.

Pre-treat material prior to screening.

14-04 Apply a dust suppressant to material.

Stabilize material during screening.

14-05 Dedicate water source to screening operation and apply water as needed to prevent dust.

Stabilize material and surrounding area immediately after screening.

14-07 Apply water to stabilize screened material and surrounding area.

Transfer height

14-10 Drop material through the screen slowly and minimize drop height.

BMP 15 STAGING AREAS, EQUIPMENT STORAGE, VEHICLE PARKING LOTS, AND MATERIAL STORAGE AREAS.

Limit visible dust opacity from vehicular operations.

15-01 Limit vehicle mileage and speed limit.

Stabilize staging area soils during use.

15-03 Pre-water and maintain surface soils in a stabilized condition.

Stabilize staging area soils at project completion.

15-09 Completed project will cover staging area with buildings, paving, and/or landscaping.

BMP 16 STOCKPILES MATERIALS (STORAGE), OTHER SOILS, ROCK OR DEBRIS, FOR FUTURE USE OR EXPORT.

Stabilize surface soils where support equipment and vehicles will operate.

16-01 Pre-water and maintain surface soils in a stabilized condition.

Stabilize stockpile materials during handling.

16-04 Remove material from the downwind side of the stockpile, when safe to do so.

16-05 Reduce height.

Stabilize stockpiles after handling.

16-07 Water stockpiles to form a crust immediately.

16-12 Avoid steep sides to prevent material sloughing.

16-13 Reduce height.

BMP 17 TAILINGS PILES, PONDS AND EROSION CONTROL.

Stabilize piles and ponds.

17-01 Pre-water and maintain surface soils in a stabilized condition.

17-05 Avoid steep sides or faces.

17-06 Minimizing the area of disturbed tailings.

17-07 Restriction the speed of vehicles in and around the tailings operation.

BMP 18 TRACKOUT PREVENTION AND CLEANUP OF MUD, SILT AND SOIL TRACKED OUT ONTO PAVED ROADS.

Prevent dust from trackout.

18-01 Clean trackout at the end of the work shift from paved surfaces to maintain dust control.

All exiting traffic must be routed over selected trackout control device(s).

18-08 Clearly establish and enforce traffic patterns to route traffic over selected trackout control device(s).

BMP20 TRENCHING WITH TRACK OR WHEEL MOUNTED EXCAVATOR, SHOVEL, BACKHOE OR TRENCHER.

Presoak soils prior to trenching activities.

20-01 Pre-water surface.

Stabilize surface soils where trenching equipment, support equipment and vehicles will operate.

20-02 Pre-water and maintain surface soils in a stabilized condition.

20-04 Limit mileage and speed.

Stabilize soils after trenching.

20-05 Apply and maintain water on excavated soil.

BMP 21 TRUCK LOADING WITH MATERIALS INCLUDING CONSTRUCTION AND DEMOLITION DEBRIS, ROCK AND SOIL.

21-01 Pre-water and maintain surface soils in a stabilized condition where loaders, support equipment and vehicles will operate.

21-03 Empty loader bucket slowly and keep loader bucket close to the truck to minimize the drop height while dumping.

Appendix H: BMP Instruction and Detail Specifications

Use this appendix if complete BMP specifications are not provided in Section 5 or 6 of the SWPPP.

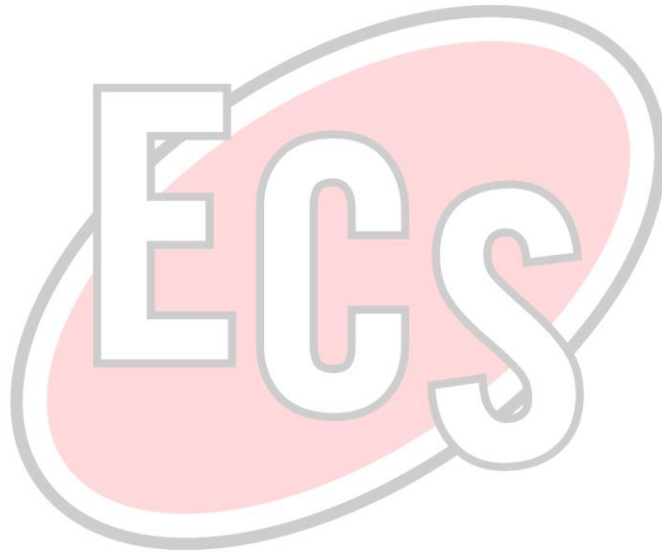

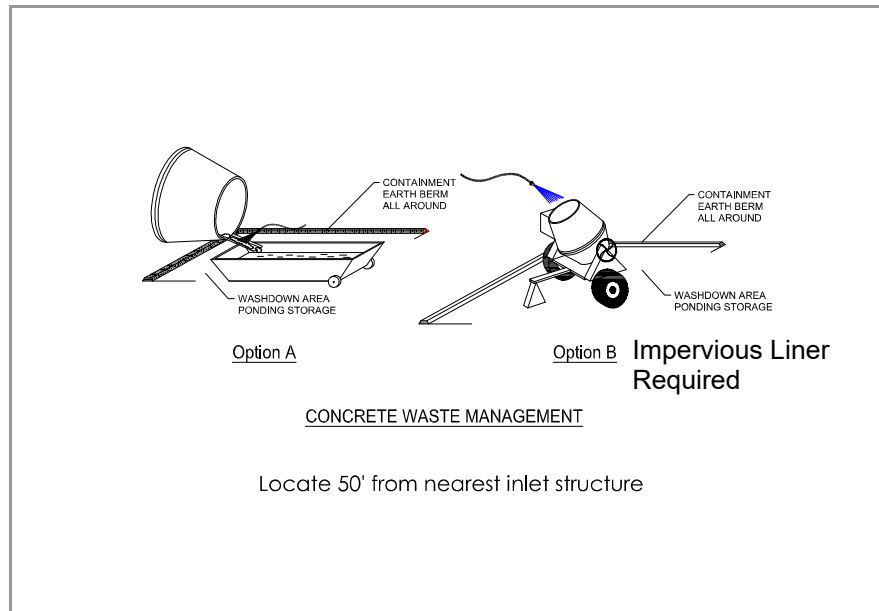

DESCRIPTION:

Prevent or reduce the discharge of pollutants to storm water from concrete waste by conducting washout off-site, performing on-site washout in a designated area, and training employees and subcontractors.

APPLICATION:

This technique is applicable to all types of sites.

INSTALLATION/APPLICATION CRITERIA:

- ◆ Store dry materials under cover, away from drainage areas.
- ◆ Minimize excess mixing of fresh concrete, mortar or cement on-site.
- ◆ Perform washout of concrete trucks off-site or in designated areas only.
- ◆ Do not wash out concrete trucks into storm drains, open ditches, streets, or streams.
- ◆ Do not allow excess concrete to be dumped on-site, except in designated areas.
- ◆ When washing concrete to remove fine particles and expose the aggregate, avoid creating runoff by draining the water within a bermed or level area. (6" tall by 6" wide).
- ◆ Train employees and subcontractors in proper concrete waste management.

LIMITATIONS:

- ◆ Off-site washout of concrete wastes may not always be possible.

MAINTENANCE:

- ◆ Inspect subcontractors to ensure that concrete wastes are being properly managed.
- ◆ If using a temporary pit, dispose hardened concrete on a regular basis.

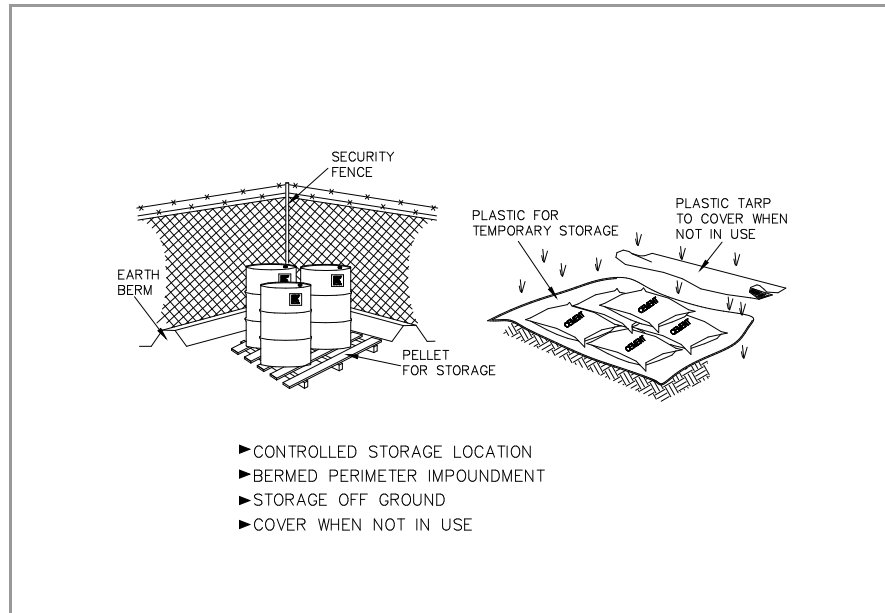
**DESCRIPTION:**

Controlled storage of on-site materials.

APPLICATION:

- ◆ Storage of hazardous, toxic, and all chemical substances.
- ◆ Any construction site with outside storage of materials.

INSTALLATION/APPLICATION CRITERIA:

- ◆ Designate a secured area with limited access as the storage location. Ensure no waterways or drainage paths are nearby.
- ◆ Construct compacted earthen berm (See Earth Berm Barrier Information Sheet), or similar perimeter containment around storage location for impoundment in the case of spills.
- ◆ Ensure all on-site personnel utilize designated storage area. Do not store excessive amounts of material that will not be utilized on site.
- ◆ For active use of materials away from the storage area ensure materials are not set directly on the ground and are covered when not in use. Protect storm drainage during use.

LIMITATIONS:

- ◆ Does not prevent contamination due to mishandling of products.
- ◆ Spill Prevention and Response Plan still required.
- ◆ Only effective if materials are actively stored in controlled location.

MAINTENANCE:

- ◆ Inspect daily and repair any damage to perimeter impoundment or security fencing.
- ◆ Check materials are being correctly stored (i.e. standing upright, in labeled containers, tightly capped) and that no materials are being stored away from the designated location.

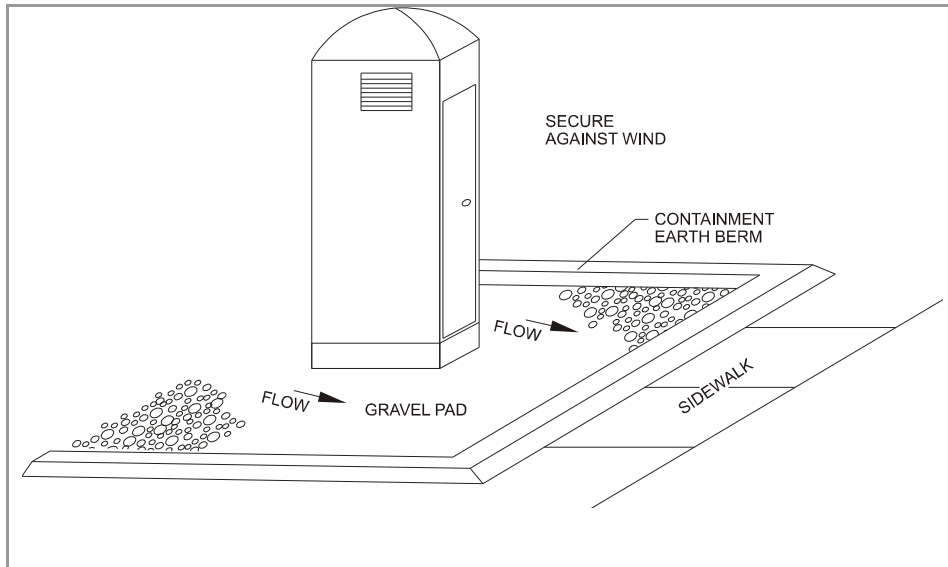
**DESCRIPTION:**

Temporary on-site sanitary facilities for construction personnel.

APPLICATION:

All sites with no permanent sanitary facilities or where permanent facility is too far from activities.

INSTALLATION/APPLICATION CRITERIA:

- ◆ Locate portable toilets in convenient locations throughout the site.
- ◆ Prepare level, gravel surface and provide clear access to the toilets for servicing and for on-site personnel.
- ◆ Construct earth berm perimeter (6" tall by 6" wide), control for spill/protection leak.

LIMITATIONS:

- ◆ No limitations.

MAINTENANCE:

- ◆ Portable toilets should be maintained in good working order by licensed service with daily observation for leak detection.
- ◆ Regular waste collection should be arranged with licensed service.
- ◆ All waste should be deposited in sanitary sewer system for treatment with appropriate agency approval.

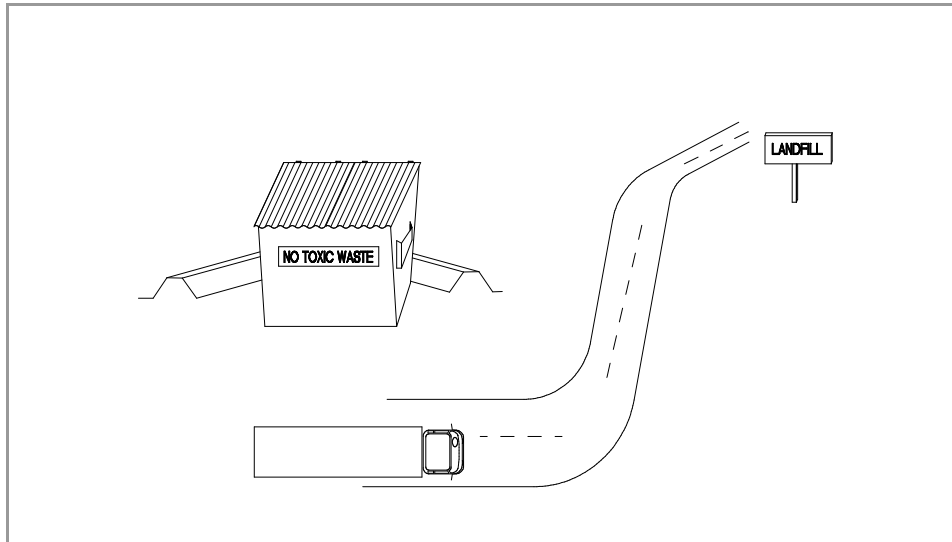
**DESCRIPTION:**

Controlled storage and disposal of solid waste generated by construction activities.

APPLICATION:

All construction sites.

INSTALLATION:

- ◆ Designate one or several waste collection areas with easy access for construction vehicles and personnel. Ensure no waterways or storm drainage inlets are located near the waste collection areas.
- ◆ Construct compacted earthen berm (See Earth Berm Barrier Information Sheet), or similar perimeter containment around collection area for impoundment in the case of spills and to trap any windblown trash.
- ◆ Use watertight containers with covers to remain closed when not in use. Provide separate containers for different waste types where appropriate and label clearly.
- ◆ Ensure all on site personnel are aware of and utilize designated waste collection area properly and for intended use only (e.g. all toxic, hazardous, or recyclable materials shall be properly disposed of separately from general construction waste).
- ◆ Arrange for periodic pickup, transfer and disposal of collected waste at an authorized disposal location. Include regular Porta-potty service in waste management activities.

LIMITATIONS:

- ◆ On-site personnel are responsible for correct disposal of waste.

MAINTENANCE:

- ◆ Discuss waste management procedures at progress meetings.
- ◆ Collect site trash daily and deposit in covered containers at designated collection areas.
- ◆ Check containers for leakage or inadequate covers and replace as needed.
- ◆ Randomly check disposed materials for any unauthorized waste (e.g. toxic materials).
- ◆ During daily site inspections check that waste is not being incorrectly disposed of on-site (e.g. burial, burning, surface discharge, discharge to storm drain).

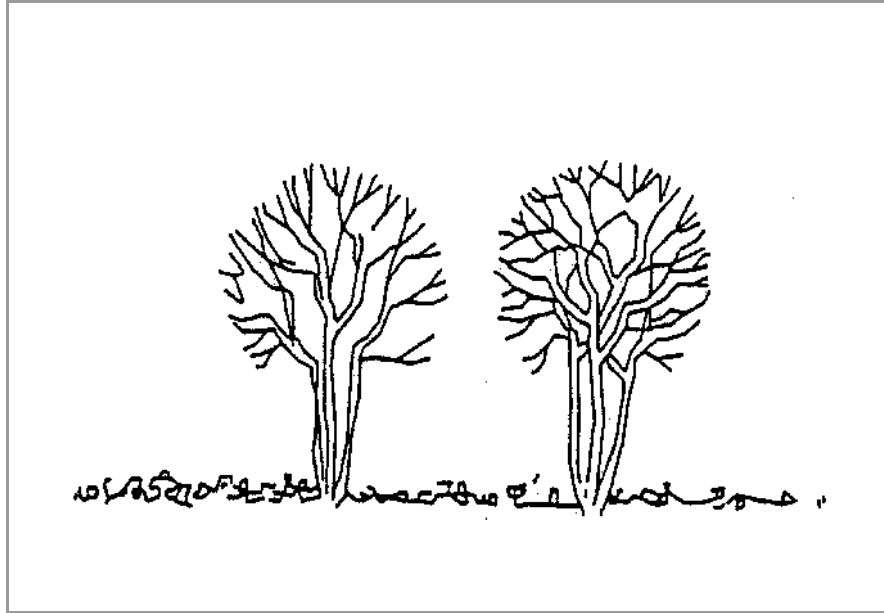
**DESCRIPTION:**

Carefully planned preservation of existing vegetation minimizes the potential of removing or injuring existing trees, vines, shrubs and/or grasses that serve as erosion controls.

APPLICATIONS:

This technique is applicable to all types of sites. Areas where preserving vegetation can be particularly beneficial are floodplains, wetlands, stream banks, steep slopes, and other areas where erosion controls would be difficult to establish, install, or maintain.

INSTALLATION/APPLICATION CRITERIA:

- ◆ Clearly mark, flag or fence vegetation or areas where vegetation should be preserved.
- ◆ Prepare landscaping plans which include as much existing vegetation as possible and state proper care during and after construction.
- ◆ Define and protect with berms, fencing, signs, etc. a setback area from vegetation to be preserved.
- ◆ Propose landscaping plans which do not include plant species that compete with the existing vegetation.
- ◆ Do not locate construction traffic routes, spoil piles, etc. where significant adverse impact on existing vegetation may occur.

LIMITATIONS:

- ◆ Requires forward planning by the owner/developer, contractor and design staff.
- ◆ For sites with diverse topography, it is often difficult and expensive to save existing trees while grading the site satisfactorily for the planned development.
- ◆ May not be cost effective with high land costs.

MAINTENANCE:

- ◆ Inspection and maintenance requirements for protection of vegetation are low.
- ◆ Maintenance of native trees or vegetation should conform to landscape plan specifications.

FLEXSTORM CATCH-IT FILTERS FOR TEMPORARY INLET PROTECTION

PRODUCT SELECTION AND SPECIFICATION DRAWING

11 GA GALVANIZED STEEL SUSPENSION SYSTEM

LIFT HANDLES

STANDARD 2" OVERFLOW AREA

STAINLESS STEEL CLAMPING BAND

REPLACEABLE SEDIMENT BAGS WITH GEOTEXTILE FILTER FABRIC

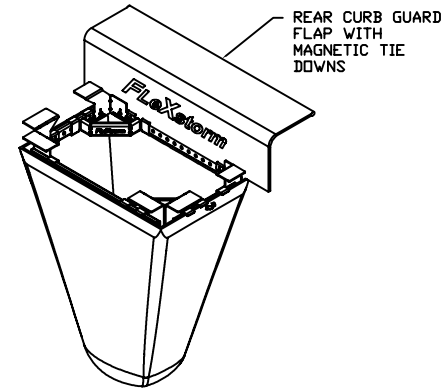

REAR CURB GUARD FLAP WITH MAGNETIC TIE DOWNS

COMBINATION INLET FILTER FOR CURB HOODS

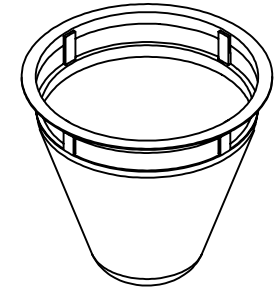

STAINLESS STEEL ROUND INLET FILTERS for NYLOPLAST CASTINGS CATCH-ITS SPECIFIED W/ FX or FX-S BAGS

TYPICAL ROUND INLET FILTER

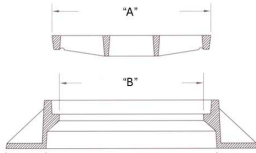

TYPICAL RECTANGULAR INLET FILTER

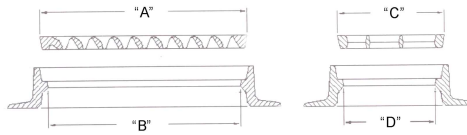

NOTES:

- ALL FRAMING IS CONSTRUCTED OF CORROSION RESISTANT STEEL (ZINC PLATED OR GALVANIZED) FOR 7 YEAR MINIMUM SERVICE LIFE.
- UPON ORDERING CONFIRMATION OF THE DOT CALLOUT, PRECAST OR CASTING MAKE AND MODEL, OR DETAILED DIMENSIONAL FORMS MUST BE PROVIDED TO CONFIGURE AND ASSEMBLE YOUR CUSTOMIZED FLEXSTORM INLET FILTER. PART NUMBER ALONE IS NOT SUFFICIENT.
- FOR WRITTEN SPECIFICATIONS AND MAINTENANCE GUIDELINES VISIT WWW.INLETFILTERS.COM

1. IDENTIFY YOUR FRAME STYLE AND SIZE		
STYLE	FRAME STYLE AND SIZE	Frame P/N:
ROUND	Small Round (up to 20.0" dia grates (A) dim)	62SRD
	Med Round (20.1" - 26.0" dia grates (A) up to 25" dia openings (B))	62MRD
	Large Round (26.1" - 32.0" dia grates (A) up to 30" openings (B))	62LRD
	XL Round (32.1" dia - 39" dia grates (A) up to 37" dia openings (B))	62XLRD
RECT/ SQUARE	Small Rect / Square (up to 16" (B) x 16" (D) openings or 64" perimeter)	62SSQ
	Med Rect / Square (up to 24" (B) x 24" (D) openings or 96" perimeter)	62MSQ
	Large Rect / Square (up to 36" (B) x 24" (D) openings or 120" perimeter)	62LSQ
	XL Rect / Square (side by side 2 pc set to fit up to 48" (B) x 36" (D) openings)	62XLSQ
COMBO INLETS	Small Rect / Square (ref Rect sizing; shipped with Magnetic Curb Flaps)	62SCB
	Med Rect / Square (ref Rect sizing; shipped with Magnetic Curb Flaps)	62MCB
	Large Rect / Square (ref Rect sizing; shipped with Magnetic Curb Flaps)	62LCB
	XL Rect / Square (ref Rect sizing; shipped with Magnetic Curb Flaps)	62XLCB
NYLOPLAST	12" diameter Nyloplast castings (Stainless Steel Framing standard)	6212NY
	15" diameter Nyloplast castings (Stainless Steel Framing standard)	6215NY
	18" diameter Nyloplast castings (Stainless Steel Framing standard)	6218NY
	24" diameter Nyloplast castings (Stainless Steel Framing standard)	6224NY
	30" diameter Nyloplast castings (Stainless Steel Framing standard)	6230NY

SPECIFICATIONS FOR STANDARD BAGS BY NOMINAL SIZE			
Nominal Bag Size	Solids Storage (CuFt)	Filtered Flow Rate at 50% Max (CFS)	
		FX (Woven)	IL (NonWoven)
Small	1.6	1.2	0.9
Medium	2.1	1.7	1.3
Large	3.8	2.7	1.9
XL	4.2	3.6	2.6

2. SELECT YOUR BAG PART NUMBER				
FLEXSTORM FILTER BAGS	(22" depth) STD Bag P/N	(12" depth) Short Bag P/N	Clean Water Flow Rate (GPM/SqFt)	Min A.O.S. (US Sieve)
FX: Standard Woven Bag	FX	FX-S	200	40
IL: IDOT Non-Woven Bag	IL	IL-S	145	70

3. CREATE YOUR FLEXSTORM INLET FILTER PART NUMBER

Frame P/N from Step 1. Filter Bag P/N from Step 2.

INSTALLATION:

- REMOVE GRATE
- DROP FLEXSTORM INLET FILTER ONTO LOAD BEARING LIP OF CASTING OR CONCRETE STRUCTURE
- REPLACE GRATE

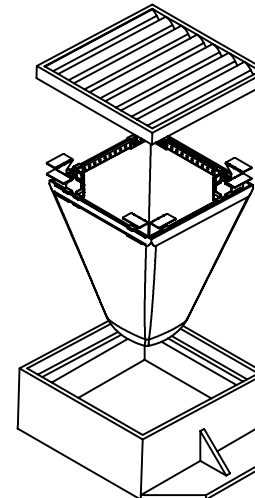



CATCH IT

ALL PRODUCTS MANUFACTURED BY INLET & PIPE PROTECTION, INC A DIVISION OF ADS, INC.
WWW.INLETFILTERS.COM
 (866) 287-8655 PH
 (630) 355-3477 FX
INFO@INLETFILTERS.COM

SIZE	DWG NO	REV
C	FLEXSTORM_CATCH_IT	A
SCALE	SHEET 1 OF 1	

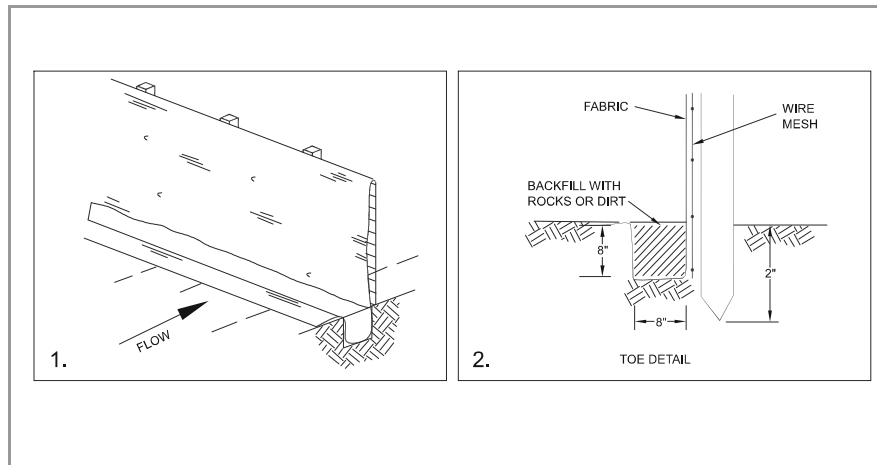

DESCRIPTION:

A temporary sediment barrier consisting of entrenched filter fabric stretched across and secured to supporting posts.

Application:

- ◆ Perimeter control: place barrier at down-gradient limits of disturbance
- ◆ Sediment barrier: place barrier at toe of slope or soil stockpile
- ◆ Protection of existing waterways: place barrier at top of stream bank
- ◆ Inlet protection: place fence surrounding catchbasins

INSTALLATION/APPLICATION CRITERIA:

- ◆ Place posts 6 feet apart on center along contour (or use preassembled unit) and drive 2 feet minimum into ground. Excavate an anchor trench immediately up-gradient of posts.
- ◆ Secure wire mesh (14 gage min. with 6-inch openings) to upslope side of posts. Attach with heavy duty 1 inch long wire staples, tie wires or hog rings.
- ◆ Cut fabric to required width, unroll along length of barrier and drape over barrier. Secure fabric to mesh with twine, staples, or similar, with trailing edge extending into anchor trench.
- ◆ Backfill trench over filter fabric to anchor.

LIMITATIONS:

- ◆ Recommended maximum drainage area of 0.5 acre per 100 feet of fence
- ◆ Recommended maximum up-gradient slope length of 150 feet
- ◆ Recommended maximum uphill grade of 2:1 (50%)
- ◆ Recommended maximum flow rate of 0.5 cfs
- ◆ Ponding should not be allowed behind fence

MAINTENANCE:

- ◆ Inspect immediately after any rainfall and at least daily during prolonged rainfall.
- ◆ Look for runoff bypassing ends of barriers or undercutting barriers.
- ◆ Repair or replace damaged areas of the barrier and remove accumulated sediment.
- ◆ Reanchor fence as necessary to prevent shortcutting.
- ◆ Remove accumulated sediment when it reaches ½ the height of the fence.

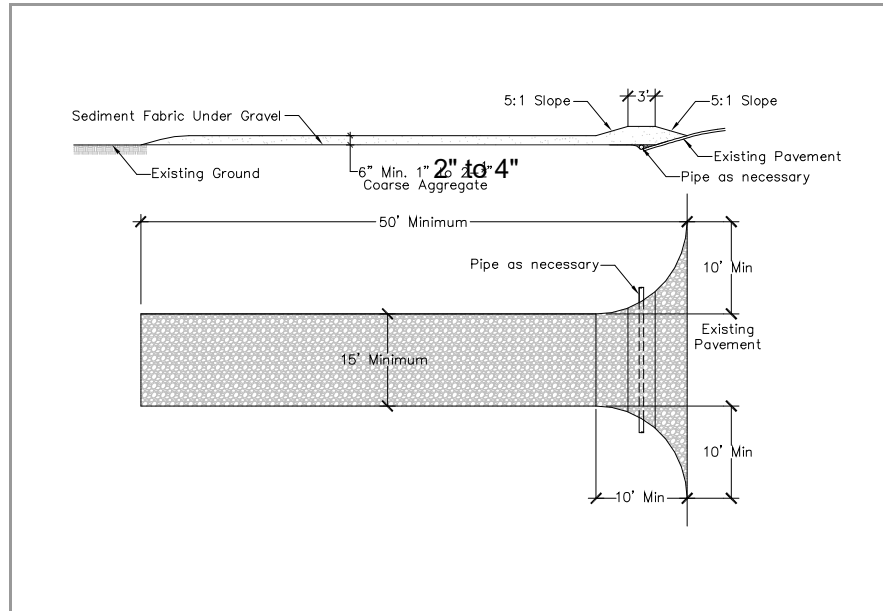

DESCRIPTION:

A stabilized pad of crushed stone located where construction traffic enters or leaves the site from or to paved surface.

APPLICATION:

At any point of ingress or egress at a construction site where adjacent traveled way is paved. Generally applies to sites over 2 acres unless special conditions exist.

INSTALLATION/APPLICATION CRITERIA:

- ◆ Clear and grub area and grade to provide maximum slope of 2%.
- ◆ Compact subgrade and place filter fabric if desired (recommended for entrances to remain for more than 3 months).
- ◆ Place coarse aggregate, 1 to 2-1/2 inches in size, to a minimum depth of 8 inches.

LIMITATIONS:

- ◆ Requires periodic top dressing with additional stones.
- ◆ Should be used in conjunction with street sweeping on adjacent public right-of-way.

MAINTENANCE:

- ◆ Inspect daily for loss of gravel or sediment buildup.
- ◆ Inspect adjacent roadway for sediment deposit and clean by sweeping or shoveling.
- ◆ Repair entrance and replace gravel as required to maintain control in good working condition.
- ◆ Expand stabilized area as required to accommodate traffic and prevent erosion at driveways.

**DESCRIPTION:**

Reduce the discharges of pollutants to stormwater from street surfaces by conducting street cleaning on a regular basis.

APPROACH:

- ◆ Prioritize cleaning to use the most sophisticated sweepers, at the highest frequency, and in areas with the highest pollutant loading.
- ◆ Restrict street parking prior to and during sweeping.
- ◆ Increase sweeping frequency just before the rainy season.
- ◆ Proper maintenance and operation of sweepers greatly increase their efficiency.
- ◆ Keep accurate operation logs to track programs.
- ◆ Sweepers effective at removing smaller particles (less than 10 microns) may generate dust that would lead to concerns over worker and public safety.
- ◆ Equipment selection can be key for this particular BMP. There are two types used, the mechanical broom sweepers (more effective at picking up large debris and cleaning wet streets), and the vacuum sweepers (more effective at removing fine particles and associated heavy metals). Many communities find it useful to have a compliment of both types in their fleet.

LIMITATIONS:

- ◆ Conventional sweepers are not able to remove oil and grease.
- ◆ Mechanical sweepers are not effective at removing finer sediments.
- ◆ Effectiveness may also be limited by street conditions, traffic congestion, presence of construction projects, climatic conditions and condition of curbs.

MAINTENANCE:

- ◆ Replace worn parts as necessary.
- ◆ Install main and gutter brooms of the appropriate weight.

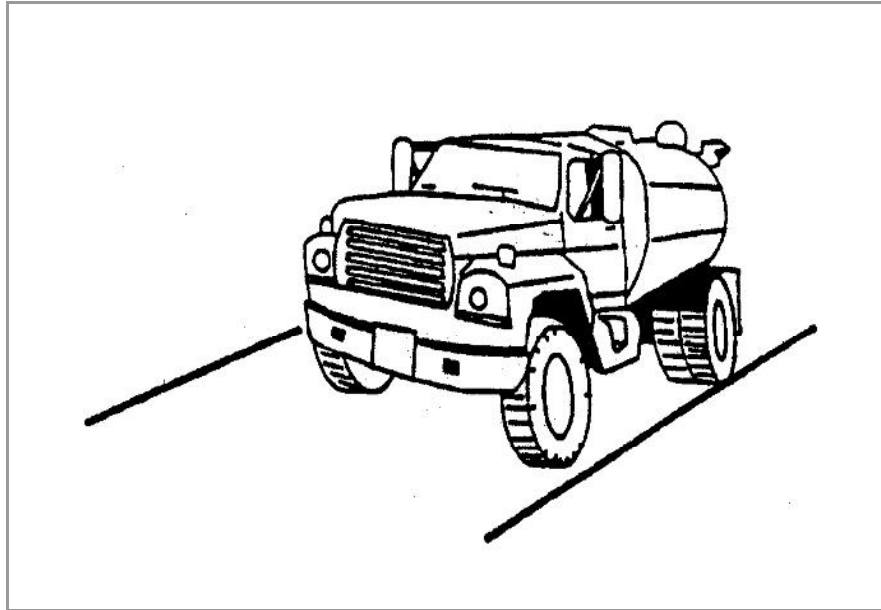
**DESCRIPTION:**

Dust control measures are used to stabilize soil from wind erosion, and reduce dust by construction activities.

APPLICATION:

Dust control is useful in any process area, loading and unloading area, material handling areas, and transfer areas where dust is generated. Street sweeping is limited to areas that are paved.

INSTALLATION/APPLICATION CRITERIA:

- ◆ Mechanical dust collection systems are designed according to the size of dust particles and the amount of air to be processed. Manufacturers' recommendations should be followed for installation (as well as the design of the equipment).
- ◆ Two kinds of street sweepers are common: brush and vacuum. Vacuum sweepers are more efficient and work best when the area is dry.
- ◆ Mechanical equipment should be operated according to the manufacturers' recommendations and should be inspected regularly.

LIMITATIONS:

- ◆ Generally more expensive than manual systems.
- ◆ May be impossible to maintain by plant personnel (the more elaborate equipment).
- ◆ Labor and equipment intensive and may not be effective for all pollutants (street sweepers).

MAINTENANCE:

If water sprayers are used, dust-contaminated waters should be collected and taken for treatment. Areas will probably need to be resprayed to keep dust from spreading.

Appendix I: Construction General Permit

If all storm water team members access the CGP via the internet while on site the following link to access the Construction General Permit is sufficient:

<https://documents.deq.utah.gov/water-quality/stormwater/construction/DWQ-2020-013890.pdf>

Otherwise, include a printed out copy of the Construction General Permit in this appendix.

