

OSPREY RANCH SUBDIVISION PHASE 1

LOCATED IN THE SOUTHEAST QUARTER OF SECTION 33 TOWNSHIP 7 NORTH RANGE 1 EAST AND THE NORTH HALF OF SECTIONS 3, AND 4 OF TOWNSHIP 6 NORTH, RANGE 1 WEST, SALT LAKE BASE AND MERIDIAN, WEBER COUNTY, UTAH, AUGUST 2022

A PART OF THE SOUTHEAST QUARTER OF SECTION 33, TOWNSHIP 7 NORTH, RANGE 1 EAST AND A PART OF THE NORTH HALF OF SECTIONS 3 AND 4 OF TOWNSHIP 6 NORTH, RANGE 1 EAST, OF THE SALT LAKE BASE AND MERIDIAN, BEGINNING AT A POINT ON THE EAST LINE OF SAID SOUTHEAST QUARTER BEING LOCATED NORTH 00°22'52" EAST 1323.89 FEET ALONG THE EAST LINE OF SAID SECTION 33 FROM THE SOUTHEAST CORNER OF SAID SECTION 33; RUNNING THENCE ALONG SAID EAST LINE SOUTH 00°22'52" WEST 672.71 FEET; THENCE NORTH 70°00'53" WEST 107.12 FEET; THENCE SOUTH 10°11'47" WEST 178.55 FEET; THENCE SOUTH 05°08'51" EAST 152.07 FEET; THENCE SOUTH 00°17'39" WEST 360.00 FEET; THENCE SOUTH 89°19'35" EAST 1690.75 FEET TO THE WEST RIGHT-OF-WAY LINE OF STATE HIGHWAY 158; THENCE ALONG SAID WEST RIGHT-OF-WAY LINE THE FOLLOWING FOUR (4) COURSES: (1) SOUTH 26°32'40" EAST 650.08 FEET; (2) SOUTH 36°16'03" EAST 1586.42 FEET; (3) ALONG THE ARC OF A 1530.00 FOOT RADIUS CURVE TO THE RIGHT 383.09 FEET, HAVING A CENTRAL ANGLE OF 14°20'46", CHORD BEARS SOUTH 26°16'20" EAST 382.09 FEET; (4) SOUTH 19°05'57" EAST 476.77 FEET; THENCE NORTH 90°00'00" WEST 4460.96 FEET; THENCE NORTH 00°19'53" EAST 1349.11 FEET; THENCE NORTH 45°00'00" EAST 160.42 FEET; THENCE NORTH 00°00'00" EAST 161.54 FEET; THENCE NORTH 53°49'45" EAST 43.58 FEET; THENCE ALONG THE ARC OF A 159.34 FOOT RADIUS CURVE TO THE RIGHT 47.46 FEET, HAVING A CENTRAL ANGLE OF 17°04'00", CHORD BEARS NORTH 19°43'35" WEST 47.29 FEET; THENCE NORTH 14°27'09" WEST 122.80 FEET; THENCE ALONG THE ARC OF A 122.92 FOOT RADIUS CURVE TO THE LEFT 126.51 FEET, HAVING A CENTRAL ANGLE OF 58°57'54", CHORD BEARS NORTH 43°34'35" WEST 121.00 FEET; THENCE ALONG THE ARC OF A 328.00 FOOT RADIUS CURVE TO THE LEFT 16.92 FEET, HAVING A CENTRAL ANGLE OF 02°57'23", CHORD BEARS NORTH 71°10'07" WEST 16.92 FEET; THENCE NORTH 00°15'55" EAST 780.64 FEET; THENCE ALONG THE ARC OF A 120.68 FOOT RADIUS CURVE TO THE LEFT 63.53 FEET, HAVING A CENTRAL ANGLE OF 30°09'48", CHORD BEARS NORTH 78°44'38" WEST 62.80 FEET; THENCE ALONG THE ARC OF A 167.15 FOOT RADIUS CURVE TO THE RIGHT 101.44 FEET, HAVING A CENTRAL ANGLE OF 34°46'15", CHORD BEARS NORTH 73°52'07" WEST 99.89 FEET; THENCE NORTH 89°30'41" WEST 483.94 FEET; THENCE NORTH 00°11'58" EAST 1283.62 FEET; THENCE SOUTH 89°28'52" EAST 1965.83 FEET TO THE POINT OF BEGINNING, CONTAINING 283.839 ACRES.

AREA CALCULATIONS

- TOTAL PROJECT AREA - 595.94 ACRES
- PHASE 1 AREA - 283.782 ACRES
- TOTAL COMMON AREA - 38.66 ACRES
- PHASE 1 COMMON AREA - 28.54 ACRES
- COMMUNITY PARK AREA - 2.05 ACRES

SURVEYOR'S CERTIFICATE

I, KLINT H. WHITNEY, DO HEREBY CERTIFY THAT I AM A LICENSED PROFESSIONAL LAND SURVEYOR IN THE STATE OF UTAH AND THAT I HOLD CERTIFICATE NO. 8227228 IN ACCORDANCE WITH TITLE 58, CHAPTER 22, OF THE PROFESSIONAL ENGINEERS AND LAND SURVEYORS ACT; FURTHER CERTIFY THAT BY AUTHORITY OF THE OWNERS I HAVE COMPLETED A SURVEY OF THE PROPERTY AS SHOWN AND DESCRIBED ON THIS PLAT AND HAVE SUBDIVIDED SAID PROPERTY INTO LOTS AND STREETS, TOGETHER WITH EASEMENTS, HEREAFTER TO BE KNOWN AS OSPREY RANCH PHASE 1 IN ACCORDANCE WITH SECTION 17-23-17 AND HAVE VERIFIED ALL MEASUREMENTS; THAT THE REFERENCE MONUMENTS SHOWN HEREON ARE LOCATED AS INDICATED AND ARE SUFFICIENT TO RETRACE OR REESTABLISH THIS SURVEY; THAT ALL LOTS MEET THE REQUIREMENTS OF THE LAND USE CODE; AND THAT THE INFORMATION SHOWN HEREIN IS SUFFICIENT TO ACCURATELY ESTABLISH THE LATERAL BOUNDARIES OF THE HEREIN DESCRIBED TRACT OF REAL PROPERTY.

SIGNED THIS ____ DAY OF _____, 2022.

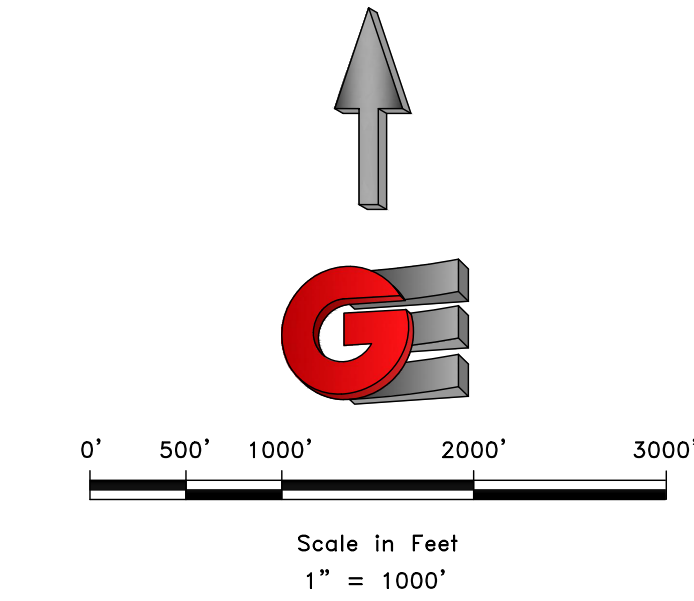
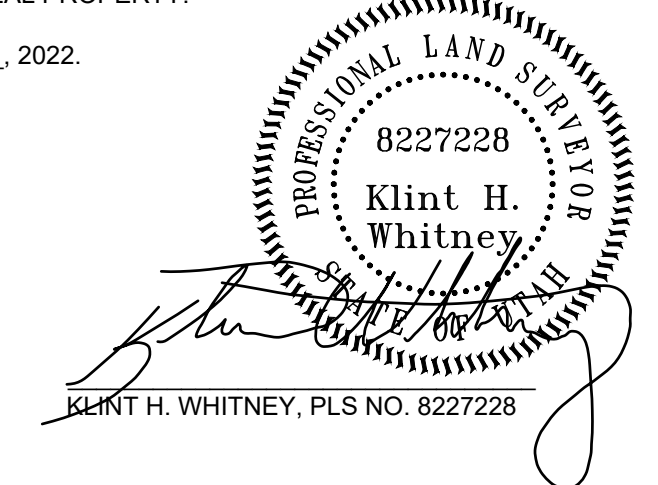

LEGEND

- ◆ WEBER COUNTY MONUMENT AS NOTED
- SET 24" REBAR AND CAP MARKED GARDNER ENGINEERING
- SUBDIVISION BOUNDARY
- LOT LINE
- - - ADJACENT PARCEL
- - - SECTION LINE
- - - EASEMENT
- x EXISTING FENCE LINE

OWNER'S DEDICATION

I THE UNDERSIGNED OWNER OF THE HEREON DESCRIBED TRACT OF LAND, HEREBY SET APART AND SUBDIVIDE THE SAME INTO LOTS, PARCELS AND STREETS AS SHOWN ON THIS PLAT AND NAME SAID TRACT:

OSPREY RANCH PHASE 1

AND DOES HEREBY GRANT AND CONVEY TO THE OSPREY RANCH OWNERS ASSOCIATION, INC. (AND ITS SUCCESSORS AND ASSIGNS) WHOSE MEMBERSHIP CONSISTS OF THE MEMBERS/OWNERS OF SAID ASSOCIATION, THEIR GRANTEEES, SUCCESSORS AND/OR ASSIGNS, A RIGHT OF WAY TO BE USED IN COMMON WITH ALL OTHERS WITHIN SAID SUBDIVISION ON, OVER AND ACROSS ALL THOSE PORTIONS OR PARTS OF SAID TRACT OF LAND DESIGNATED AND DEPICTED ON SAID PLAT AS PRIVATE STREET (PRIVATE RIGHTS-OF-WAY) FOR ACCESS TO THE INDIVIDUAL LOTS, WITH SUCH PRIVATE STREETS TO BE MAINTAINED BY SAID ASSOCIATION, AND DOES ALSO HEREBY GRANT AND CONVEY TO SAID ASSOCIATION ALL THOSE PART OR PORTIONS OF SAID TRACT OF LAND DESIGNATED AND DEPICTED ON SAID PLAT AS COMMON AREAS, WHICH ARE TO BE USED FOR PRIVATE RECREATIONAL AND OPEN SPACE PURPOSES BY AND FOR THE BENEFIT OF EACH ASSOCIATION MEMBER/OWNER IN COMMON WITH ALL OTHERS IN THE SUBDIVISION, WITH SUCH COMMON AREAS TO BE MAINTAINED BY SAID ASSOCIATION, AND DOES ALSO HEREBY GRANT AND CONVEY TO SAID ASSOCIATION ALL THOSE PARTS OR PORTIONS OF SAID TRACT OF LAND DESIGNATED AND DEPICTED ON SAID PLAT AS TRAILS AND TRAIL EASEMENTS, INCLUDING ANY SUCH TRAILS OR TRAIL EASEMENTS LOCATED ON ANY COMMON AREAS OR ON ANY INDIVIDUAL LOTS, WHICH TRAILS AND TRAIL EASEMENTS ARE TO BE USED FOR PRIVATE RECREATIONAL PURPOSES BY AND FOR THE BENEFIT OF THE ASSOCIATION'S MEMBERS/OWNERS AND IN COMMON WITH ALL OTHERS IN THE SUBDIVISION, WITH SUCH TRAILS AND TRAIL EASEMENTS TO BE MAINTAINED BY SAID ASSOCIATION, AND DOES HEREBY RESERVE UNTO ITSELF, AND IT GRANTEEES AND ASSIGNS, A PERPETUAL RIGHT OF WAY OF THE PRIVET STREETS, WHICH THE UNDERSIGNED OWNER MAY GRANT AND ASSIGN TO ANY ADJOINING SUBDIVISIONS THAT MAY BE SUBDIVIDED BY SAID OWNER, ITS SUCCESSORS, OR ASSIGNS, AND ALSO GRANTS AND DEDICATES TO WEBER COUNTY A PERPETUAL OPEN SPACE RIGHT AND EASEMENT ON AND OVER THE COMMON AREAS TO GUARANTEE TO WEBER COUNTY THAT SUCH COMMON AREAS REMAIN OPEN AND UNDEVELOPED EXCEPT FOR APPROVED RECREATIONAL, PARKING AND OPEN SPACE PURPOSES, AND ALSO GRANTS AND DEDICATES A PERPETUAL RIGHT AND EASEMENT OVER, UPON AND UNDER THE LANDS DESIGNATED ON THE PLAT AS PUBLIC UTILITY, STORM WATER DETENTION PONDS AND DRAINAGE EASEMENTS, THE SAME TO BE USED FOR THE INSTALLATION, MAINTENANCE AND OPERATION OF PUBLIC UTILITY SERVICE LINES, STORM DRAINAGE FACILITIES OR FOR THE PERPETUAL PRESERVATION OF WATER DRAINAGE CHANNELS IN THEIR NATURAL STATE WHICHEVER IS APPLICABLE AS MAY BE AUTHORIZED BY THE GOVERNING AUTHORITY WITH NO BUILDINGS OR STRUCTURES BEING ERRECTED WITHIN SUCH EASEMENTS.

SIGNED THIS ____ DAY OF _____, 2022.

OSPREY RANCH, LLC

BY: JOHN LEWIS, MANAGING MEMBER

ACKNOWLEDGEMENT

STATE OF UTAH)
COUNTY OF WEBER)

On this ____ day of _____, 2022, personally appeared before me JOHN LEWIS, whose identity is personally known to me (or proven on the basis of satisfactory evidence) and who by me duly sworn/affirmed, did say that he/she is the MANAGING MEMBER of OSPREY RANCH, LLC, and that said document was signed by him/her in behalf of said Corporation by Authority of its Bylaws, or (Resolution of its Board of Directors), and said JOHN LEWIS acknowledged to me that said Corporation executed the same.

STAMP

NOTARY PUBLIC

CURVE TABLE					
CURVE #	LENGTH	RADIUS	DELTA	CHORD BEARING	CHORD LENGTH
C1	47.46	159.34	17°04'00"	N19° 43' 28"W	47.29
C2	126.51	122.92	58°57'54"	N43° 34' 35"W	121.00
C3	16.92	328.00	2°57'23"	N71° 10' 07"W	16.92
C4	63.53	120.68	30°09'48"	N78° 44' 38"W	62.80
C5	101.44	167.15	34°46'15"	N73° 52' 07"W	99.89
C6	383.09	1530.00	14°20'46"	S26° 16' 20"E	382.09

NOTES

- ZONE FV-3 CURRENT YARD SETBACKS: FRONT 30', SIDE 20' - SIDE FACING STREET ON CORNER 30', REAR MAIN BUILDING 30' - ACCESSORY BUILDING 10'.
- SUBJECT PROPERTY FALLS WITHIN FEMA FLOOD ZONE "X" - AREAS DETERMINED TO BE OUTSIDE THE 0.2% ANNUAL CHANCE FLOODPLAIN, PER FEMA MAP NO. 49057C0237F WITH AN EFFECTIVE DATE OF JUNE 2, 2015.

NARRATIVE

THE PURPOSE OF THIS SURVEY WAS TO CREATE A SUBDIVISION ON THE PROPERTY AS SHOWN AND DESCRIBED HEREON. THE SURVEY WAS ORDERED BY OSPREY RANCH LLC. THE CONTROL USED TO ESTABLISH THE BOUNDARY WAS THE EXISTING WEBER COUNTY SURVEY MONUMENTATION AS SHOWN AND NOTED HEREON. THE BASIS OF BEARING IS THE EAST LINE OF SECTION 33, TOWNSHIP 7 NORTH, RANGE 1 EAST, OF THE SALT LAKE BASE AND MERIDIAN WHICH BEARS NORTH 00°22'52" EAST WEBER COUNTY, UTAH NORTH, NAD 83 STATE PLANE GRID BEARING. THE RIGHT-OF-WAY OF HIGHWAY 158 WAS ESTABLISHED BY DRAWINGS RECEIVED FROM U.D.O.T. REGION 1 FEDERAL AID PROJECT H99-0158(116)0 PIN:522 DATED 4/30/2012. WARRANTY DEEDS RECORDED AS ENTRY NUMBERS 3143604, 3145237, 3145286 AND DEEDS OF ADJOINING PROPERTY OWNERS, RECORD OF SURVEY NUMBERS 1002, 293, 4608, 5102, 3584, AND THE DEDICATED PLATS OF BIG SKY ESTATES NO. 1, BIG SKY ESTATES NO. 2, BLAKE HOLLEY SUBDIVISION, EDEN ESTATES SUBDIVISION WERE ALSO USED TO DETERMINE BOUNDARY LOCATION.

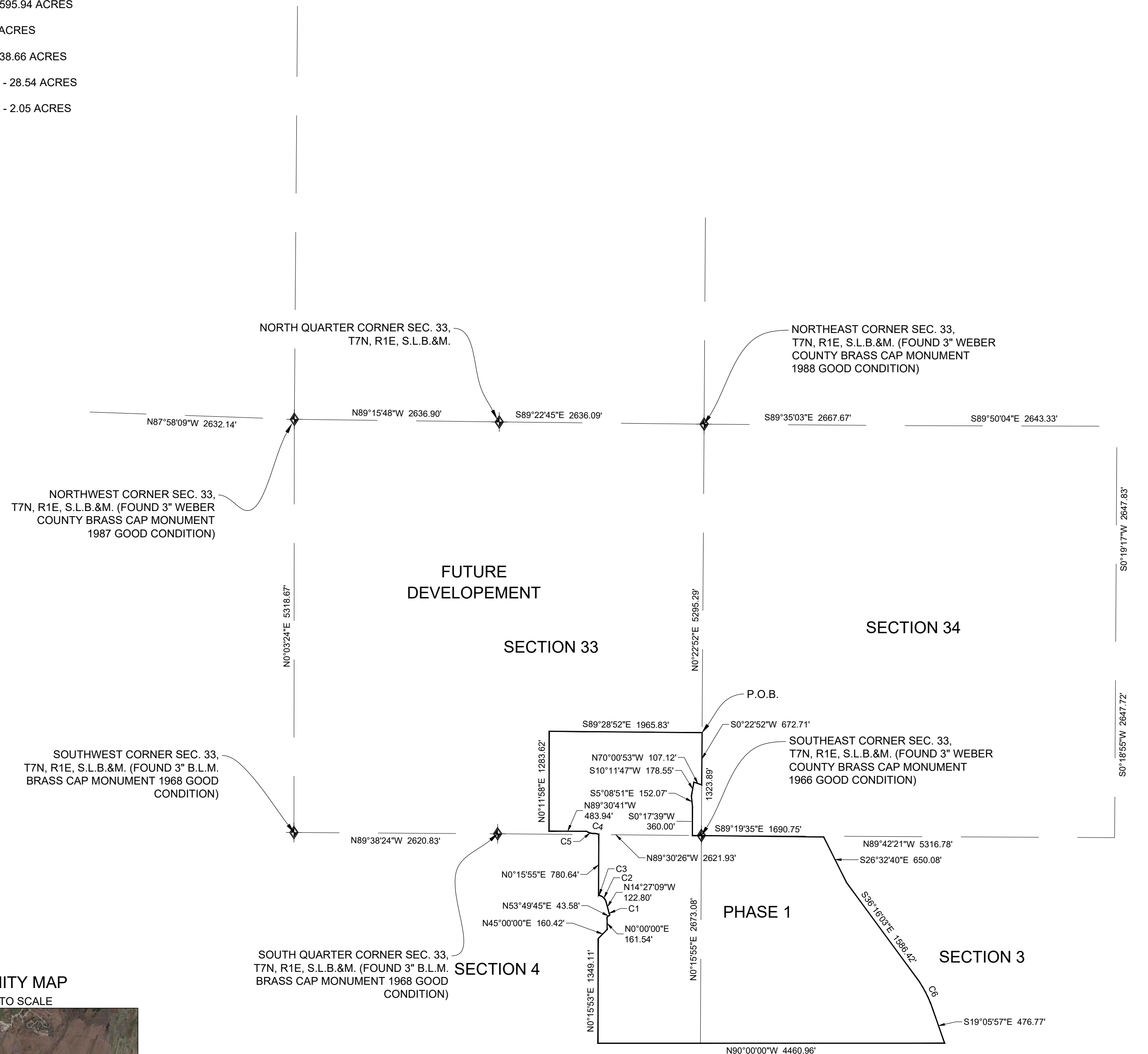

VICINITY MAP
NOT TO SCALE

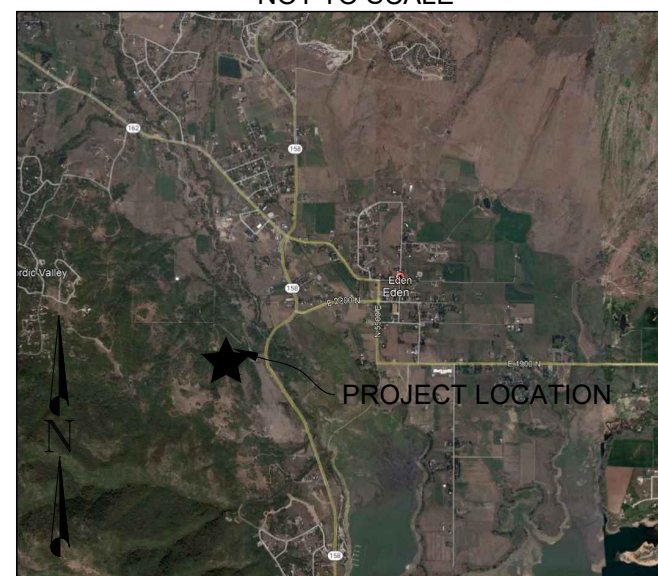

WEBER COUNTY SURVEYOR

I HEREBY CERTIFY THAT THE WEBER COUNTY SURVEYOR'S OFFICE HAS REVIEWED THIS PLAT AND ALL CONDITIONS FOR APPROVAL BY THIS OFFICE HAVE BEEN SATISFIED. THE APPROVAL OF THIS PLAT BY THE WEBER COUNTY SURVEYOR DOES NOT RELIEVE THE LICENSED LAND SURVEYOR WHO EXECUTED THIS PLAT FROM THE RESPONSIBILITIES AND/OR LIABILITIES ASSOCIATED THEREWITH.

SIGNED THIS ____ DAY OF _____, 2022.

COUNTY SURVEYOR

WEBER COUNTY ATTORNEY

I HAVE EXAMINED THE FINANCIAL GUARANTEE AND OTHER DOCUMENTS ASSOCIATED WITH THIS SUBDIVISION PLAT AND IN MY OPINION THEY CONFORM WITH THE COUNTY ORDINANCE APPLICABLE THERETO AND NOW IN FORCE AND EFFECT.

SIGNED THIS ____ DAY OF _____, 2022.

COUNTY ATTORNEY

WEBER COUNTY ENGINEER

I HEREBY CERTIFY THAT THE REQUIRED PUBLIC IMPROVEMENT STANDARDS AND DRAWINGS FOR THIS SUBDIVISION CONFORM WITH COUNTY STANDARDS AND THE AMOUNT OF THE FINANCIAL GUARANTEE IS SUFFICIENT FOR THE INSTALLATION OF THESE IMPROVEMENTS.

SIGNED THIS ____ DAY OF _____, 2022.

COUNTY ENGINEER

WEBER COUNTY COMMISSION ACCEPTANCE

THIS IS TO CERTIFY THAT THIS SUBDIVISION PLAT, THE DEDICATION OF STREETS AND OTHER PUBLIC WAYS AND FINANCIAL GUARANTEE OF PUBLIC IMPROVEMENTS ASSOCIATED WITH THIS SUBDIVISION THEREON ARE HEREBY APPROVED AND ACCEPTED BY THE COMMISSIONERS OF WEBER COUNTY, UTAH.

SIGNED THIS ____ DAY OF _____, 2022.

CHAIRMAN, WEBER COUNTY COMMISSION

ATTEST: _____
NAME/TITLE

WEBER COUNTY PLANNING COMMISSION APPROVAL

THIS IS TO CERTIFY THAT THIS SUBDIVISION WAS DULY APPROVED BY THE WEBER COUNTY PLANNING COMMISSION.

SIGNED THIS ____ DAY OF _____, 2022.

CHAIRMAN, WEBER COUNTY PLANNING COMMISSION

WEBER - MORGAN HEALTH DEPARTMENT

I DO HEREBY CERTIFY THAT THE SOILS, PERCOLATION RATES, AND SITE CONDITION FOR THIS SUBDIVISION HAVE BEEN INVESTIGATED BY THIS OFFICE AND ARE APPROVED FOR ON-SITE WASTEWATER DISPOSAL SYSTEMS.

SIGNED THIS ____ DAY OF _____, 2022.

DIRECTOR WEBER-MORGAN HEALTH DEPT.

OSPREY RANCH SUBDIVISION PHASE 1

LOCATED IN THE SOUTHEAST QUARTER OF SECTION 33 TOWNSHIP 7 NORTH RANGE 1 EAST AND THE NORTH HALF OF SECTIONS 3, AND 4 OF TOWNSHIP 6 NORTH, RANGE 1 WEST, SALT LAKE BASE AND MERIDIAN, WEBER COUNTY, UTAH, AUGUST 2022

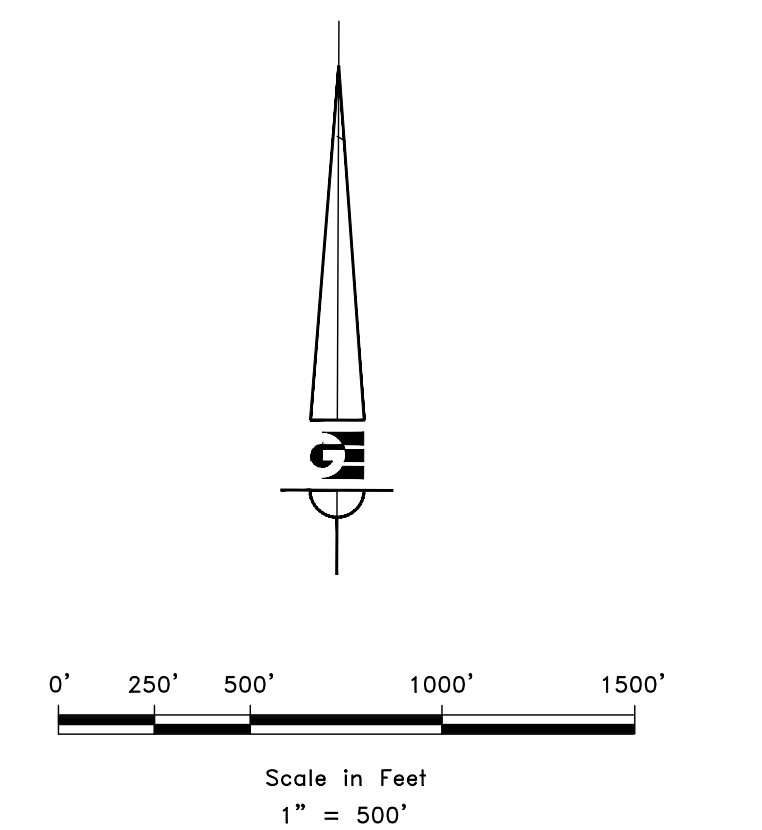
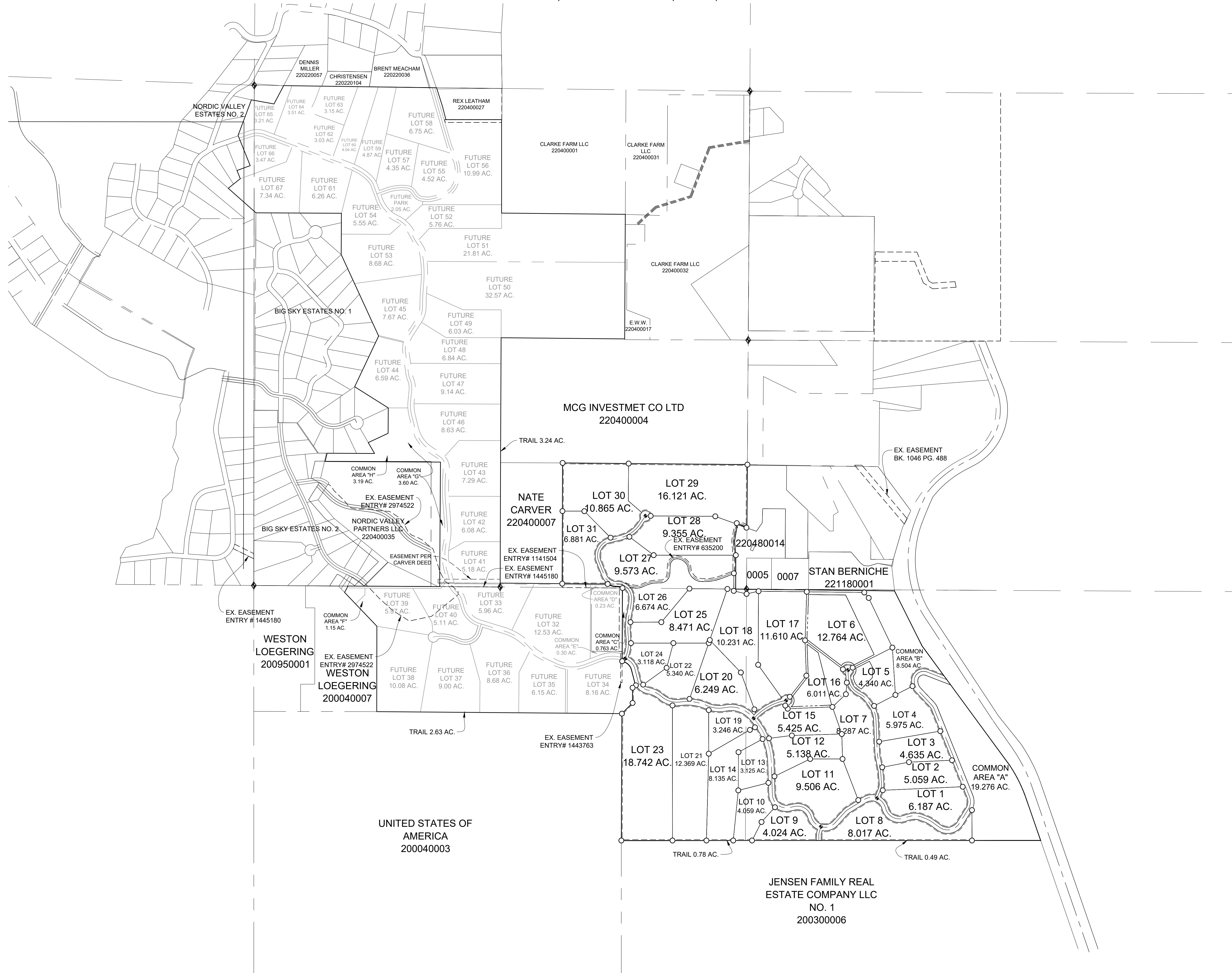

- LEGEND**
- ◆ WEBER COUNTY MONUMENT AS NOTED
 - SET 24" REBAR AND CAP MARKED GARDNER ENGINEERING
 - SUBDIVISION BOUNDARY
 - LOT LINE
 - - - ADJACENT PARCEL
 - - - SECTION LINE
 - - - EASEMENT
 - x EXISTING FENCE LINE

I:\CS_SERVER\LAND_DESKTOP\1201 - LEWIS HOMES\2105 - OSPREY RANCH\SUBDIVISION\OSPREY RANCH PHASE 1.PC 08/18/22.DWG

DEVELOPER: OSPREY RANCH LLC JOHN LEWIS 3718 NORTH WOLF CREEK DRIVE EDEN, UTAH, 84310 801-430-1507	S2 7	COUNTY RECORDER
		ENTRY NO. _____ FEE PAID _____ FILED FOR AND RECORDED _____ AT _____ IN BOOK _____ OF OFFICIAL RECORDS, PAGE _____ RECORDED FOR _____ COUNTY RECORDER BY: _____
CIVIL • LAND PLANNING MUNICIPAL • LAND SURVEYING 5150 SOUTH 375 EAST OGDEN, UT OFFICE: 801-476-0202 FAX: 801-476-0066		

OSPREY RANCH SUBDIVISION PHASE 1

LOCATED IN THE SOUTHEAST QUARTER OF SECTION 33 TOWNSHIP 7 NORTH RANGE 1 EAST AND THE NORTH HALF OF SECTIONS 3, AND 4 OF TOWNSHIP 6 NORTH, RANGE 1 WEST, SALT LAKE BASE AND MERIDIAN, WEBER COUNTY, UTAH, AUGUST 2022

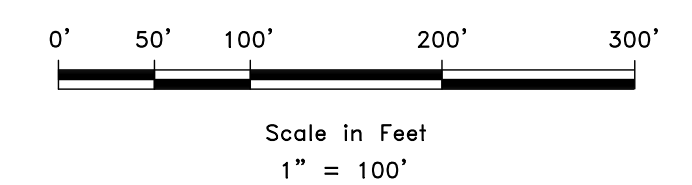
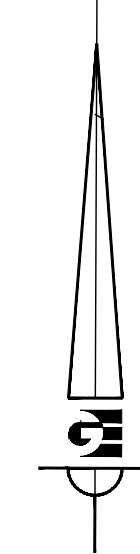
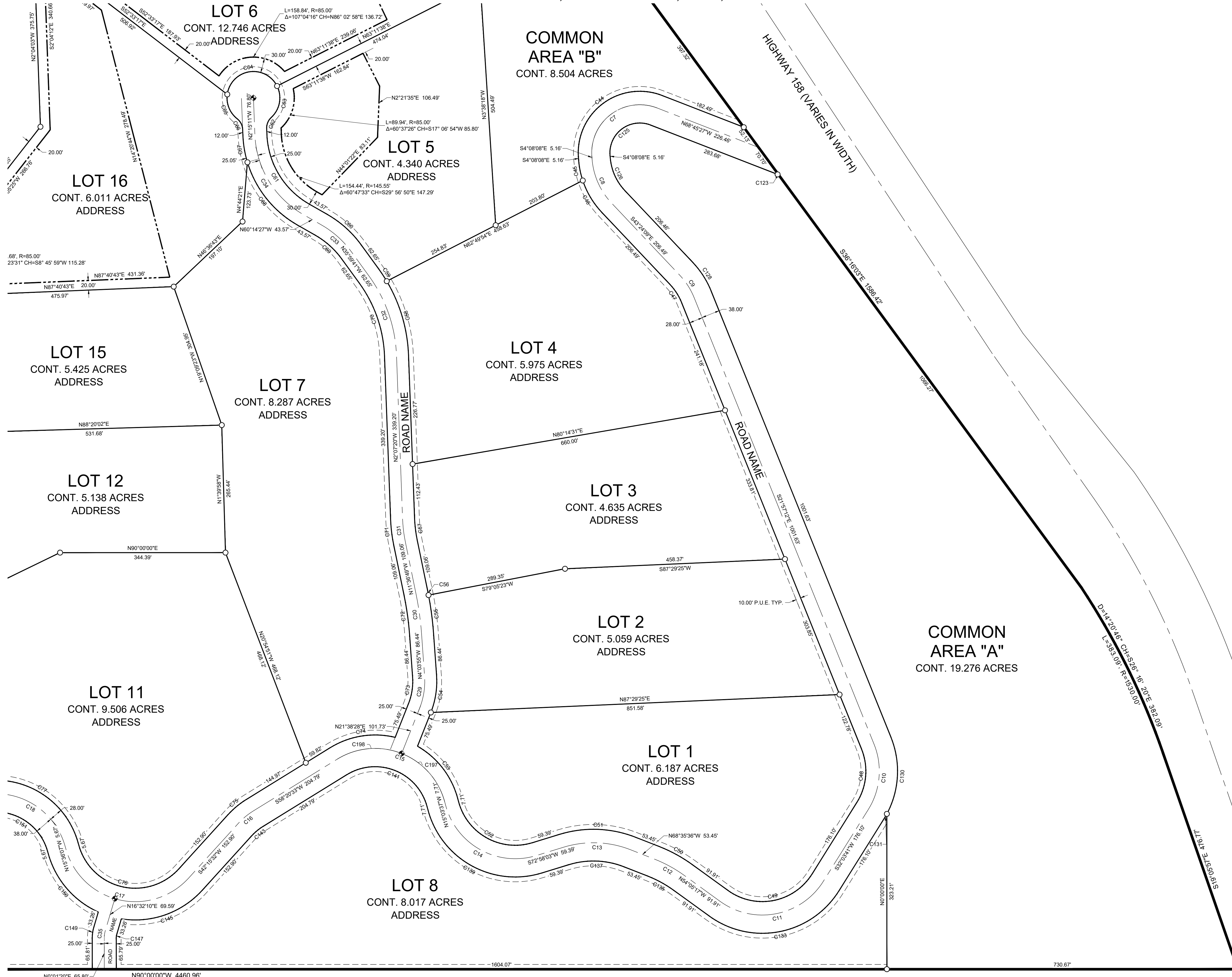

LEGEND

- WEBER COUNTY MONUMENT AS NOTED
- SET 24" REBAR AND CAP MARKED GARDNER ENGINEERING
- SUBDIVISION BOUNDARY
- LOT LINE
- ADJACENT PARCEL
- SECTION LINE
- EASEMENT
- EXISTING FENCE LINE
- BUILDABLE AREA

I:\CS_SERVER\LAND_DESKTOP\1201_LEWIS_HOMES\2105_OSPREY_RANCH\SURVEY\DWG\ARCHIVE\OSPREY_RANCH_PHASE_1_PC_081622.DWG

DEVELOPER: OSPREY RANCH LLC JOHN LEWIS 3718 NORTH WOLF CREEK DRIVE EDEN, UTAH, 84310 801-430-1507	S3 7	COUNTY RECORDER ENTRY NO. _____ FEE PAID _____ FILED FOR AND RECORDED _____ AT _____ IN BOOK _____ OF OFFICIAL _____ RECORDS, PAGE _____ RECORDED _____ FOR _____ COUNTY RECORDER _____ BY: _____
GARDNER ENGINEERING CIVIL • LAND PLANNING MUNICIPAL • LAND SURVEYING 5150 SOUTH 375 EAST OGDEN, UT OFFICE: 801-476-0202 FAX: 801-476-0066		

OSPREY RANCH SUBDIVISION PHASE 1

LOCATED IN THE SOUTHEAST QUARTER OF SECTION 33 TOWNSHIP 7 NORTH RANGE 1 EAST AND THE NORTH HALF OF SECTIONS 3, AND 4 OF TOWNSHIP 6 NORTH, RANGE 1 WEST, SALT LAKE BASE AND MERIDIAN, WEBER COUNTY, UTAH, AUGUST 2022

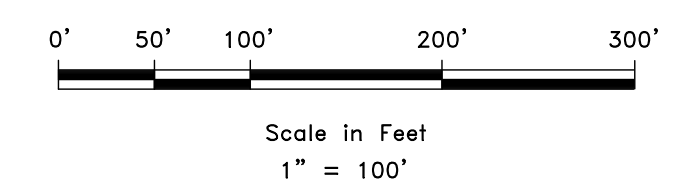
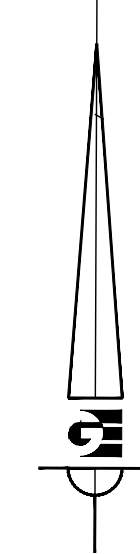
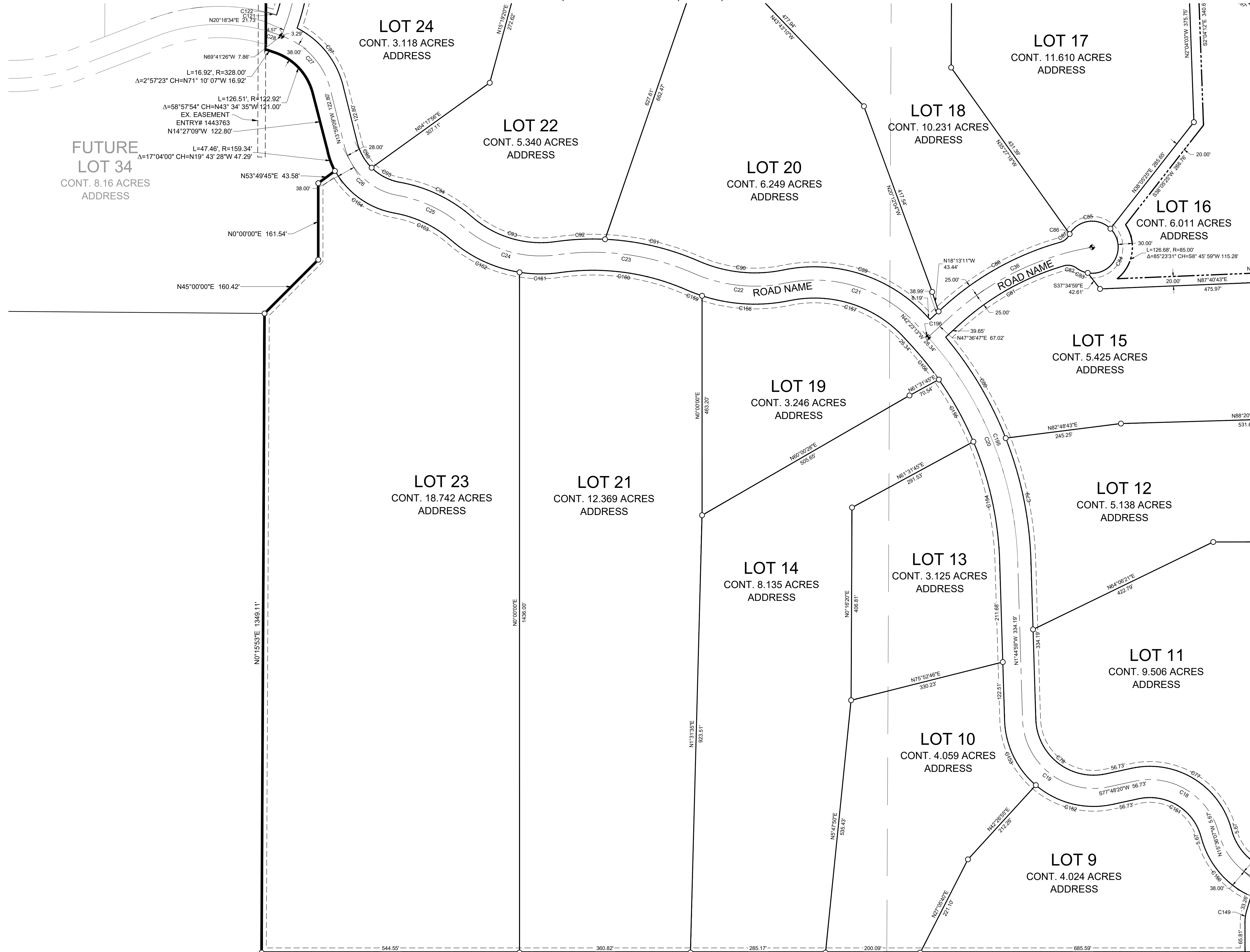

LEGEND

- WEBER COUNTY MONUMENT AS NOTED
- SET 24" REBAR AND CAP MARKED GARDNER ENGINEERING
- SUBDIVISION BOUNDARY
- LOT LINE
- ADJACENT PARCEL
- SECTION LINE
- EASEMENT
- EXISTING FENCE LINE
- BUILDABLE AREA

DEVELOPER:
OSPREY RANCH LLC
JOHN LEWIS
3718 NORTH WOLF CREEK DRIVE
EDEN, UTAH, 84310
801-430-1507

S4
7

COUNTY RECORDER
ENTRY NO. _____ FEE PAID _____
FILED FOR AND RECORDED _____
AT _____ IN BOOK _____ OF OFFICIAL _____
RECORDS, PAGE _____ RECORDED _____
FOR _____
COUNTY RECORDER _____
BY: _____

GARDNER ENGINEERING
CIVIL • LAND PLANNING
MUNICIPAL • LAND SURVEYING
5150 SOUTH 375 EAST OGDEN, UT
OFFICE: 801-476-0202 FAX: 801-476-0066

U:\CE_SERVER\LAND_DESKTOP\1201 - LEWIS HOMES\2105 - OSPREY RANCH\SURVEY\DWG\ARCHIVE\OSPREY RANCH PHASE 1.PC 081622.DWG

OSPREY RANCH SUBDIVISION PHASE 1

LOCATED IN THE SOUTHEAST QUARTER OF SECTION 33 TOWNSHIP 7 NORTH RANGE 1 EAST AND THE NORTH HALF OF SECTIONS 3, AND 4 OF TOWNSHIP 6 NORTH, RANGE 1 WEST, SALT LAKE BASE AND MERIDIAN, WEBER COUNTY, UTAH, AUGUST 2022

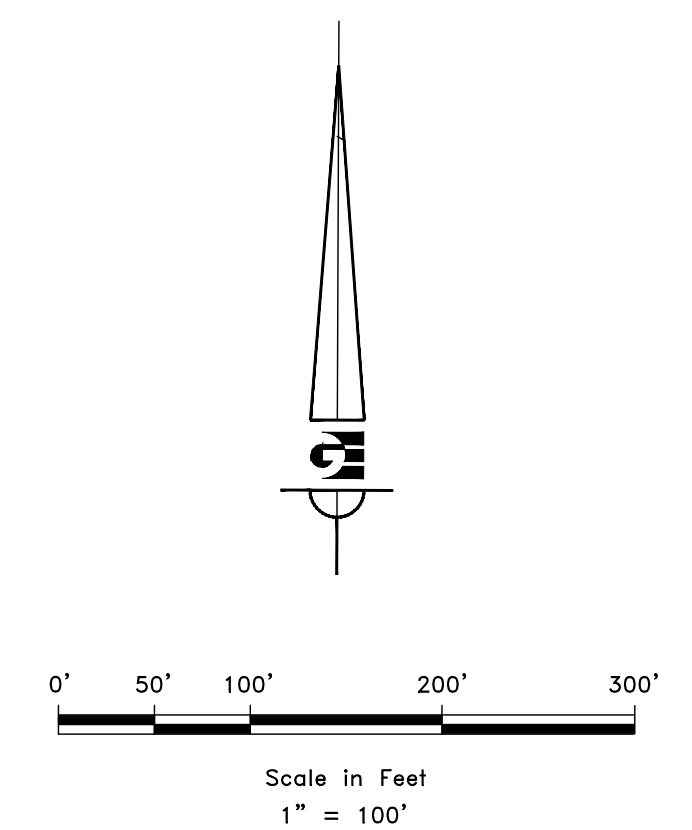
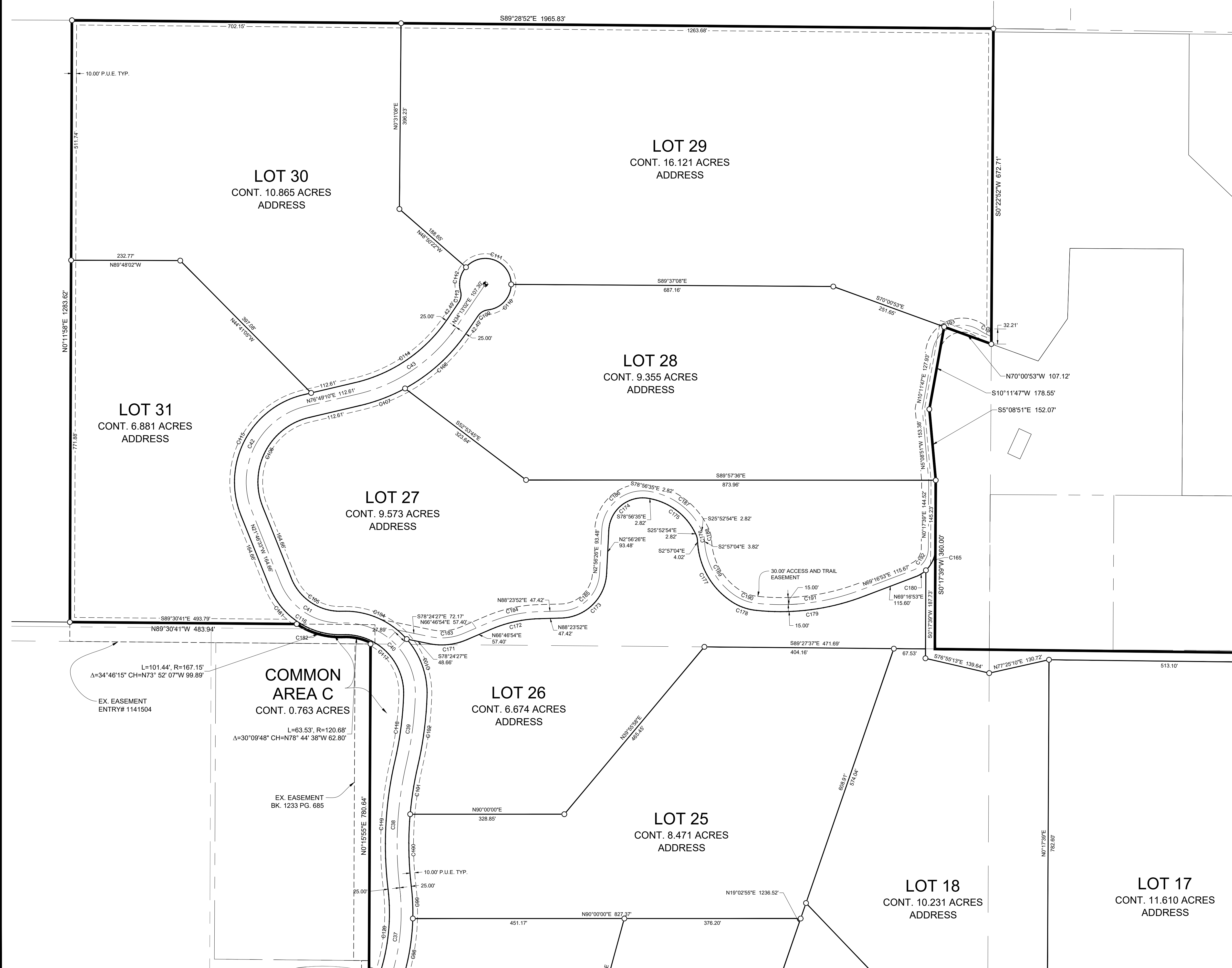

- LEGEND**
- ◆ WEBER COUNTY MONUMENT AS NOTED
 - SET 24" REBAR AND CAP MARKED GARDNER ENGINEERING
 - SUBDIVISION BOUNDARY
 - LOT LINE
 - - - ADJACENT PARCEL
 - - - SECTION LINE
 - - - EASEMENT
 - - - EXISTING FENCE LINE

DEVELOPER: OSPREY RANCH LLC JOHN LEWIS 3718 NORTH WOLF CREEK DRIVE EDEN, UTAH, 84310 801-430-1507	S5 7	COUNTY RECORDER
		ENTRY NO. _____ FEE PAID _____ FILED FOR AND RECORDED _____ AT _____ IN BOOK _____ OF OFFICIAL _____ RECORDS, PAGE _____ RECORDED _____ FOR _____ COUNTY RECORDER _____ BY: _____
CIVIL • LAND PLANNING MUNICIPAL • LAND SURVEYING 5150 SOUTH 375 EAST OGDEN, UT OFFICE: 801-476-0202 FAX: 801-476-0066		

U:\CS_SERVER\LAND_DESKTOP\1201_LEWIS_HOMES\2105_OSPREY_RANCH\SURVEY\DWG\ARCHIVE\OSPREY_RANCH_PHASE_1_PC_081622.DWG

OSPREY RANCH SUBDIVISION PHASE 1

LOCATED IN THE SOUTHEAST QUARTER OF SECTION 33 TOWNSHIP 7 NORTH RANGE 1 EAST AND THE NORTH HALF OF SECTIONS 3, AND 4 OF TOWNSHIP 6 NORTH, RANGE 1 WEST, SALT LAKE BASE AND MERIDIAN, WEBER COUNTY, UTAH, AUGUST 2022

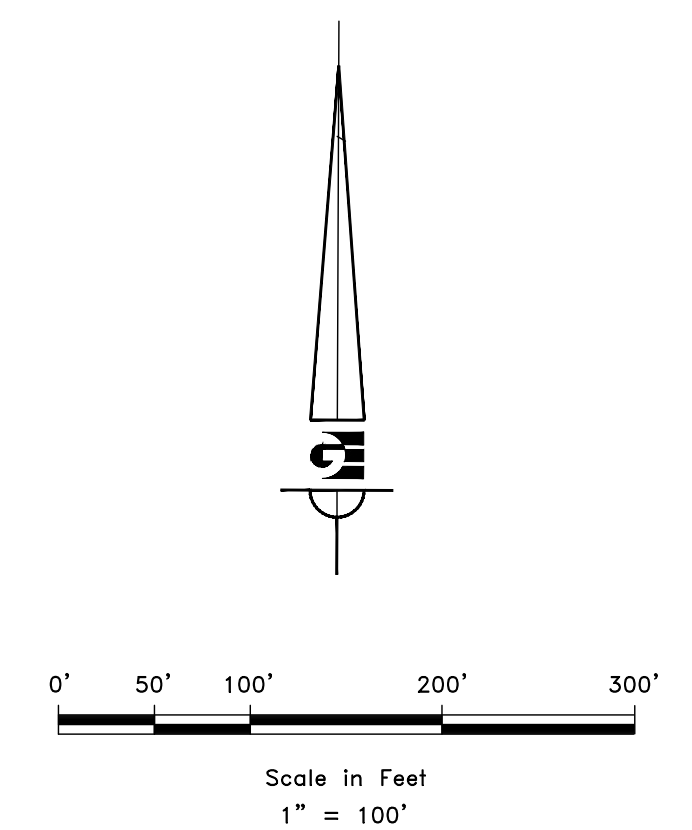
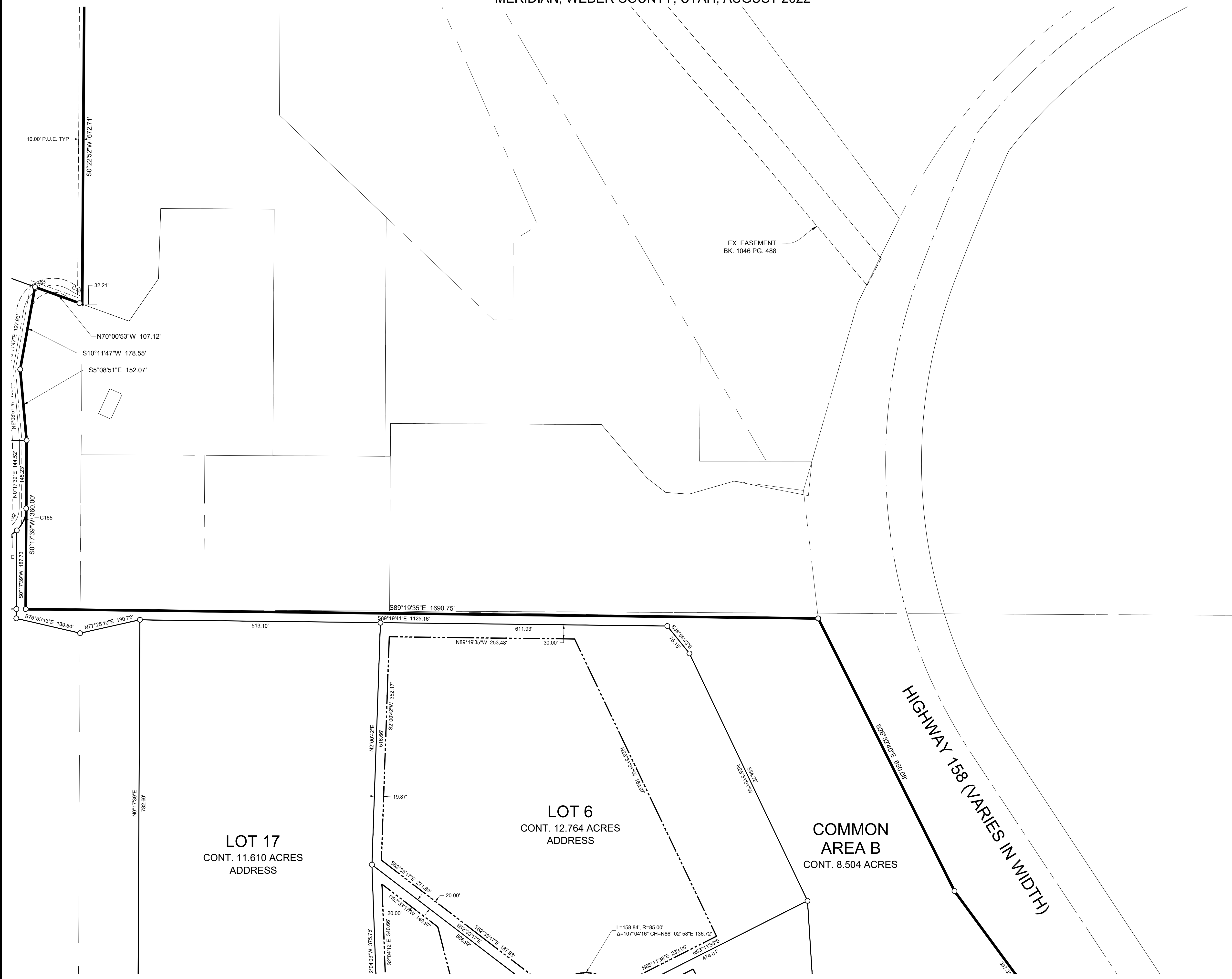

- LEGEND**
- ◆ WEBER COUNTY MONUMENT AS NOTED
 - SET 24" REBAR AND CAP MARKED GARDNER ENGINEERING
 - SUBDIVISION BOUNDARY
 - LOT LINE
 - - - ADJACENT PARCEL
 - - - SECTION LINE
 - - - EASEMENT
 - - - EXISTING FENCE LINE
 - - - BUILDABLE AREA

I:\CE_SERVER\LAND_DESKTOP1\201 - LEWIS HOMES\2105 - OSPREY RANCH SURVEY\DWG\ARCHIVE\OSPREY RANCH PHASE 1.PC 081822.DWG

DEVELOPER: OSPREY RANCH LLC JOHN LEWIS 3718 NORTH WOLF CREEK DRIVE EDEN, UTAH, 84310 801-430-1507	S6	COUNTY RECORDER
	7	ENTRY NO. _____ FEE PAID _____
 GARDNER ENGINEERING CIVIL • LAND PLANNING MUNICIPAL • LAND SURVEYING 5150 SOUTH 375 EAST OGDEN, UT OFFICE: 801-476-0202 FAX: 801-476-0066	FILED FOR AND RECORDED _____	
	AT _____ IN BOOK _____ OF OFFICIAL _____	
	RECORDS, PAGE _____ RECORDED _____	
	FOR _____	
		COUNTY RECORDER _____
		BY: _____

