



## Land Use Permit

### Weber County Planning Commission

2380 Washington Blvd. STE 240

Ogden, UT 84401

Phone: (801) 399-8791 FAX: (801) 399-8862

[webercountyutah.gov/planning](http://webercountyutah.gov/planning)

**Permit Number: LUP236-2022**

Permit Type: Structure

Permit Date: 07/07/2022

### Applicant

**Name:** Toby Bright  
**Business:**  
**Address:** 5025 W 2550 S  
Ogden, UT 84401  
**Phone:** 801-430-6098

### Owner

**Name:** Same as applicant  
**Business:**  
**Address:** , UT  
**Phone:**

### Parcel

**Parcel:** 150860028

**Zoning:** A-2 **Area:** 1.05 **Sq Ft:**  
**Address:** 5025 W 2550 S OGDEN, UT 84401

**Lot(s):** **Subdivision:**  
**T - R - S - QS:** 6N - 2W - 32 -

### Proposal

**Proposed Structure:** six foot fence

**Proposed Structure Height:** 6

**# of Dwelling Units:** 0

**# Off Street Parking Reqd:** 0

**Building Footprint:** 0

**Max Structure Height in Zone:**

**# of Accessory Bldgs:** 0

**\*Is Structure > 1,000 Sq. Ft?** N/A

\*If True Need Certif. Statement

### Permit Checklist

**Access Type:** Across front lot line

**Greater than 4218 ft above sea level?** N/A

**Additional Setback Reqd. ?** N/A

**> 200 ft from paved Road?** N/A

**Culinary Water District:** NA

**Alternative Access File #** NA

**Wetlands/Flood Zone?** N/A

**Meet Zone Area Frontage?** N/A

**Hillside Review Reqd?** N/A

**Waste Water System:** NA

### Comments

Proposal is a 6 ft fence. Toby is planning to place the fence 8" above the grade, which I have told him he can do. Site plan shows fence on owners property line.

# Land Use Permit

## Structure Setback Graphic: New Dwelling, Addition, Etc.

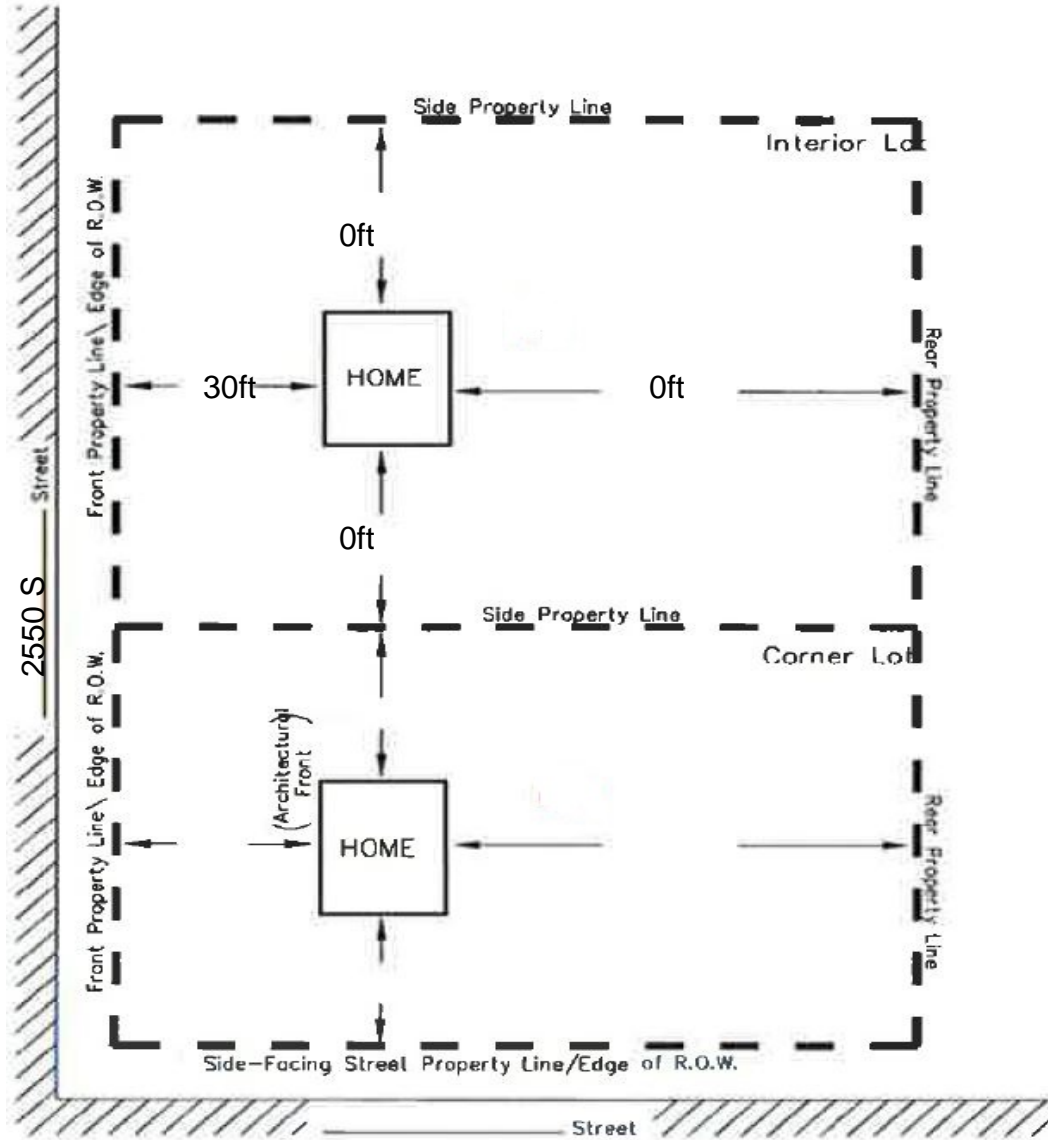

### MINIMUM YARD SETBACKS New Dwelling, Addition, Etc.

**NOTICE FOR APPLICANT (Please Read Before Signing)**

Proposals for the installation of an individual water supply and for a sanitary waste disposal system (septic tank) for any structure designed for human occupation must be approved by Weber County Health Department prior to installation.

**Steven Burton**

**07/07/2022**

\_\_\_\_\_  
Planning Dept. Signature of Approval

\_\_\_\_\_  
Date

I hereby certify that I have read and examined this application and know the same to be true and correct. All provisions of laws and ordinances governing this land use will be complied with whether specified herein or not. I make this statement under penalty of perjury.

\_\_\_\_\_  
Contractor/Owner Signature of Approval

\_\_\_\_\_  
Date