

Tarakee Farm® PRUD No. 1

A PRUD Subdivision

A part of Section 9, T6N, R2W, SLB&M, U.S. Survey

Weber County, Utah

May 2022

* See All Sheets*

NOTES

- All construction shall conform to Weber County standards and specifications.
- Underground utility piping materials will meet or exceed the County Standards.
- All manholes to be vacuum test. BOA Tape shall be used and other water tightness materials per manufacturer.
- Culinary water services will be 3/4" Dia. C-900 DR14 PVC to be centered on the frontage and extended 10' beyond the right of way line.
- 4" Sanitary sewer laterals to be constructed 10' down slope from the center of the lot and extended 10' beyond the right of way line.
- 4" Land drain laterals to be constructed at the low corner of the lot and extended 10' beyond the right of way line.
- Saw Cut Existing Asphalt to provide a smooth clean edge.
- All Utility trenches within the Street right of way shall have a City approved imported granular backfill.
- Thrust block all water line fittings.
- All inlet grates shall be bicycle safe.
- All fire hydrants and access roads shall be installed prior to any construction of any buildings.
- All fire hydrants shall be placed with 4 1/2 inch connections facing the point of access for the Fire Department Apparatus.
- Prior to the beginning of construction of any buildings, a fire flow test of new hydrants shall be conducted to verify the actual fire flow for this project. The Fire Prevention Division shall witness this test and shall be notified a minimum of 48 hours prior to the test.
- Curb & gutter installed along 2200 South Street will be set to ensure a 1.5% minimum/3.0% Maximum cross slope from edge of asphalt. Contractor to verify prior to construction of curb.
- An excavation permit is required for all work done within the existing Right of Way.
- A Storm Water Construction Activity Permit is required for any construction that disturbs more than 5000 Sq. Ft. or 200 Cubic Yards.
- All improvements need to be either installed or escrowed prior to recording of the subdivision.
- If construction activity will disturb more than an acre then a State SWPPP will be required. This includes the construction of the homes etc. on each lot.

GENERAL UTILITY NOTES:

- Coordinate all utility connections to building with plumbing plans and building contractor.
- Verify depth and location of all existing utilities prior to constructing any new utility lines. Notify Civil Engineer of any discrepancies or conflicts prior to any connections being made.
- All catch basin and inlet box grates are to be bicycle proof.
- All inlet boxes located in curb and gutter are to be placed parallel to the curb and gutter and set under the frame and grate. Improperly placed boxes will be removed and replaced at no additional cost to the owner. Precast or cast in place boxes are acceptable.
- Refer to the site electrical plan for details and locations of electrical lines, transformers and light poles.
- Gas lines, telephone lines, and cable TV lines are not a part of these plans unless otherwise noted.
- Water meters are to be installed per city standards and specifications. It will be the contractor's responsibility to install all items required.
- Water lines, valves, fire hydrants, fittings etc. are to be constructed as shown. Contractor is responsible to construct any vertical adjustments necessary to clear sewer, storm drain or other utilities as necessary including valve boxes and hydrant spools to proper grade.
- Field verify all existing and/or proposed Roof Drain/Roof Drain down spout connections to Storm Water System with Civil, Plumbing & Architectural plans. Notify Engineer of any discrepancies.
- All gravity flow utility lines shall be installed prior to any pressurized utilities unless written permission is obtained from the engineer of record before construction begins.

UTILITY PIPING MATERIALS:

- All piping to be installed per manufacturers recommendations. Refer to project specifications for more detailed information regarding materials, installation, etc.

CULINARY SERVICE LATERALS

- 3/4" to 2" diameter pipe - CTS PE4710 HDPE SDR9
- Over 2" diameter pipe - AWWA C-900 Class 150 pipe

WATER MAIN LINES AND FIRE LINES

- Pipe material as shown on utility plan view or to meet city standards.

SANITARY SEWER LINES

- All sewer piping to be Polyvinyl Chloride (PVC) sewer pipe, ASTM D 3034, Type PSM, SDR 35
- Sewer Lines will be marked with marking tape above the line.

STORM DRAIN LINES

- 10" pipes or smaller - Polyvinyl Chloride (PVC) sewer pipe, ASTM D3034, Type PSM, SDR 35
- 12" to 21" pipes - Concrete Pipe, ASTM C14, Class III up to 13' of cover. For greater than 13' feet of cover, use reinforced concrete pipe and classes listed below.
- 24" pipes or larger - Reinforced Concrete Pipe, ASTM C76, Class III up to 13' of cover, Class IV for 13' to 21' of cover, Class V for 21' to 32' of cover, and Special Design for cover greater than 32 feet.

CAUTION NOTICE TO CONTRACTOR

The contractor is specifically cautioned that the location and/or elevation of existing utilities as shown on these plans are based on records of the various utility companies and, where possible, measurements taken in the field. The information is not to be relied on as being exact or complete. The contractor must call the appropriate utility company at least 48 hours before any excavation to request exact field location of utilities. It shall be the responsibility of the contractor to relocate all existing utilities which conflict with the proposed improvements shown on the plans.

PRIVATE ENGINEER'S NOTICE TO CONTRACTORS

The Contractor agrees that he shall assume sole and complete responsibility for job site conditions during the course of construction of this project, including safety of all persons and property; that this requirement shall apply continuously and not be limited to normal working hours; and that the contractor shall defend, indemnify, and hold the owner and the engineer harmless from any and all liability, real or alleged, in connection with the performance of work on this project, excepting for liability arising from the sole negligence of the owner or the engineer.

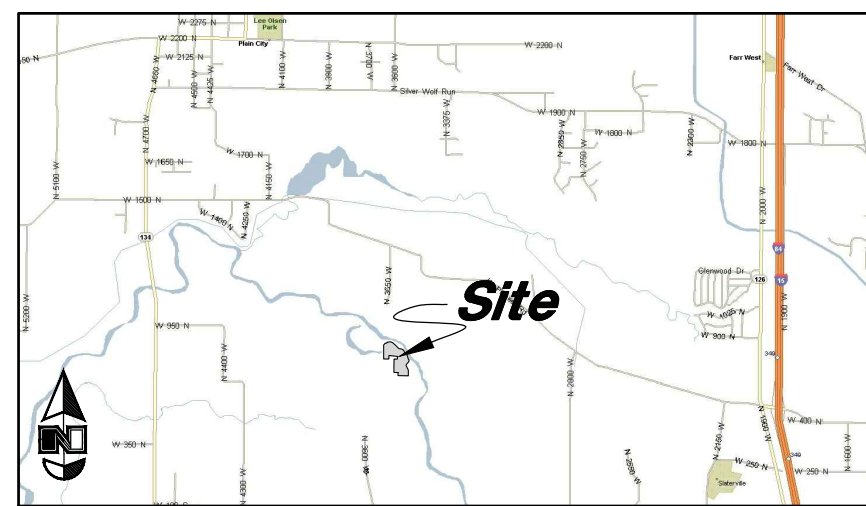
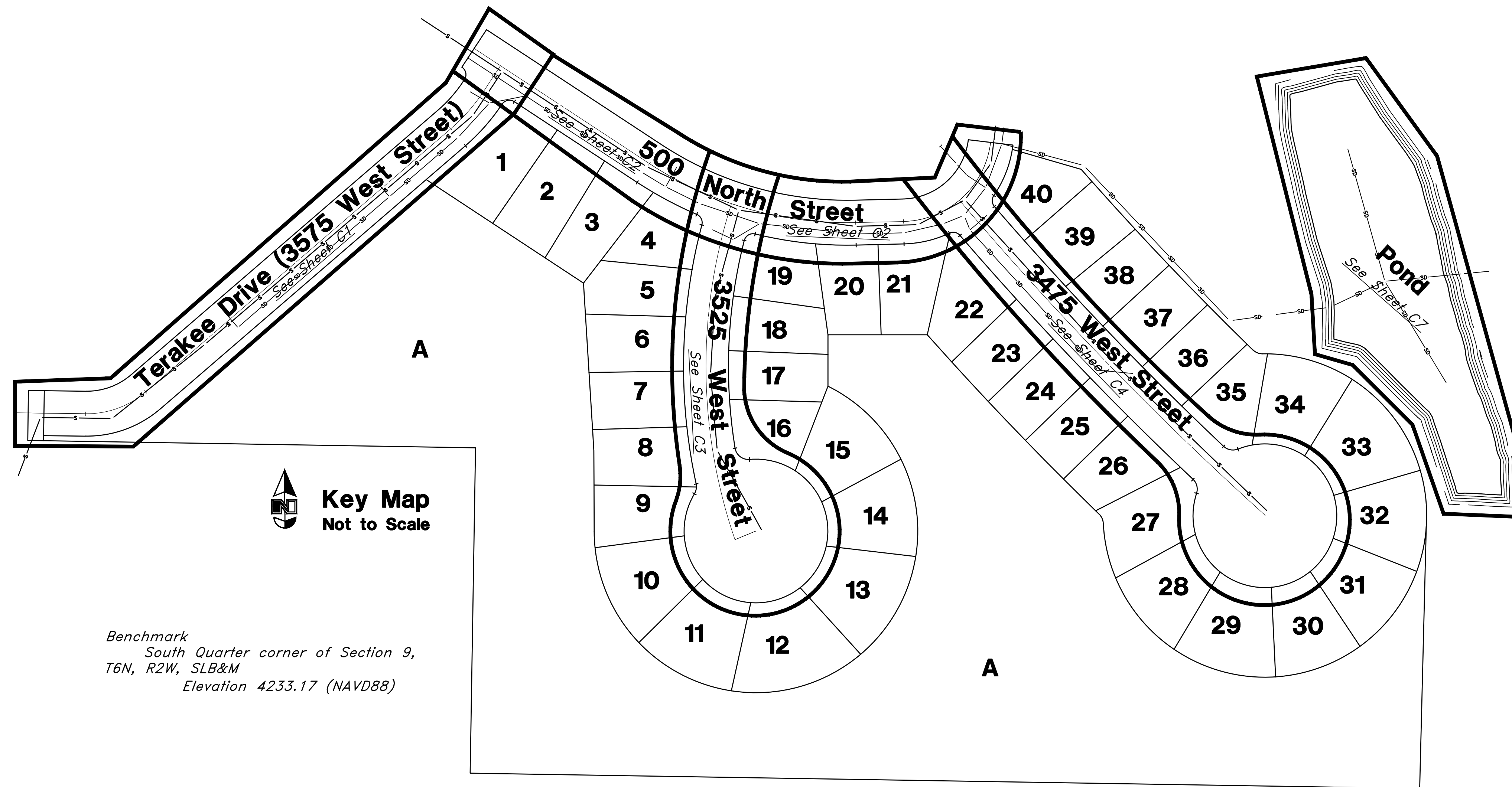

Legend

(Note: All items may not appear on drawing)

- San. Sewer Manhole
- Water Manhole
- Storm Drain Manhole
- Cleanout
- Electrical Manhole
- Catch Basins
- Exist. Fire Hydrant
- Fire Hydrant
- Exist. Water Valve
- Water Valve
- Sanitary Sewer
- Culinary Water
- Gas Line
- Irrigation Line
- Storm Drain
- Telephone Line
- Secondary Waterline
- Power Line
- Fire Line
- Land Drain
- Power pole
- Power pole w/guy
- Light Pole
- Fence
- Flowline of ditch
- Overhead Power line
- Corrugated Metal Pipe
- Concrete Pipe
- Reinforced Concrete Pipe
- Ductile Iron
- Polyvinyl Chloride
- Top of Asphalt
- Edge of Asphalt
- Centerline
- Flowline
- Finish Floor
- Top of Curb
- Top of Wall
- Top of Walk
- Top of Concrete
- Natural Ground
- Finish Grade
- Match Existing
- Fire Department Connection
- Exist. Contour
- Finish Grade
- Exist. Grade
- Ridge Line
- Direction of Flow
- Existing Asphalt
- New Asphalt
- Existing Concrete
- New Concrete

Call before you Dig
Avoid cutting underground utility lines. Be safe.



GREAT BASIN ENGINEERING

574 EAST 1475 SOUTH, SUITE 100, BOULDER, UTAH 84103
WWW.GREATBASINENGINEERING.COM

Plan & Profile

Terakee Farm PRUD No. 1

Approximately 1000 North 3600 West
Weber County, Utah
A part of Section 9, T6N, R2W, SLB&M, U.S. Survey

May, 2022

SHEET NO.

GO

of 7

16N704 - AM-1

CONSTRUCTION SERVICES

Legend

(Note: All items may not appear on drawing)

- San. Sewer Manhole
- Water Manhole
- Storm Drain Manhole
- Cleanout
- Electrical Manhole
- Catch Basins
- Exist. Fire Hydrant
- Fire Hydrant
- Exist. Water Valve
- Water Valve
- Sanitary Sewer
- Culinary Water
- Gas Line
- Irrigation Line
- Storm Drain
- Telephone Line
- Secondary Waterline
- Power Line
- Fire Line
- Land Drain
- Power pole
- Power pole w/guy
- Light Pole
- Fence
- Flowline of ditch
- Overhead Power line
- Corrugated Metal Pipe
- Concrete Pipe
- Reinforced Concrete Pipe
- Ductile Iron
- Polyvinyl Chloride
- Top of Asphalt
- Edge of Asphalt
- Centerline
- Flowline
- Finish Floor
- Top of Curb
- Top of Wall
- Top of Walk
- Top of Concrete
- Natural Ground
- Finish Grade
- Match Existing
- Fire Department Connection
- Finish Contour
- Exist. Contour
- Finish Grade
- Exist. Grade
- Ridge Line

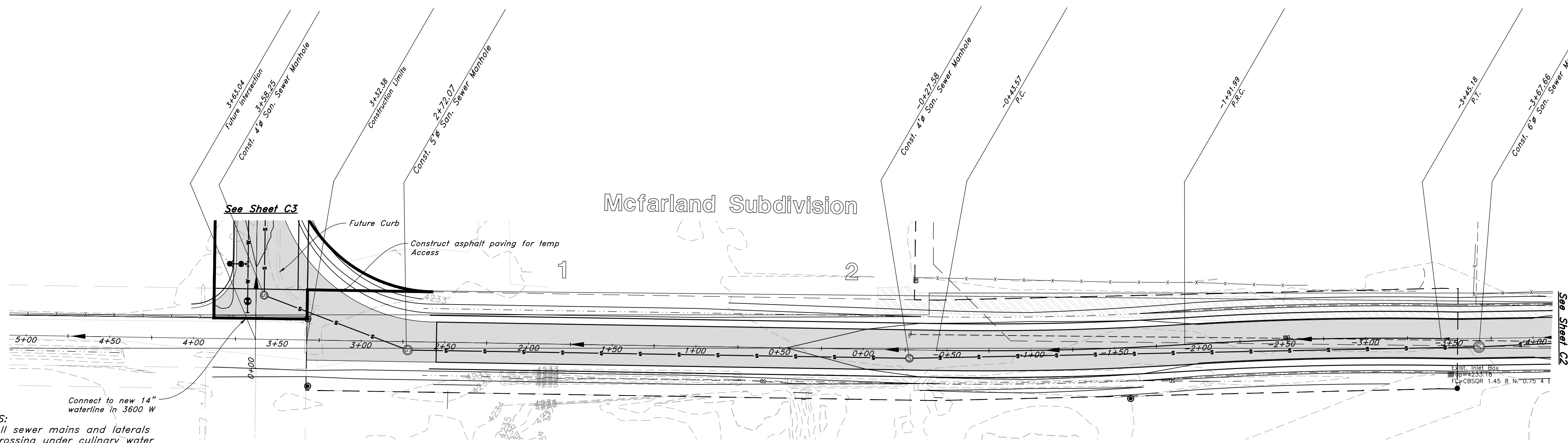

NOTES:
 1. All sewer mains and laterals crossing under culinary water with less than 18" of clearance shall be sleeved per TWW standard drawings

3600 West Street

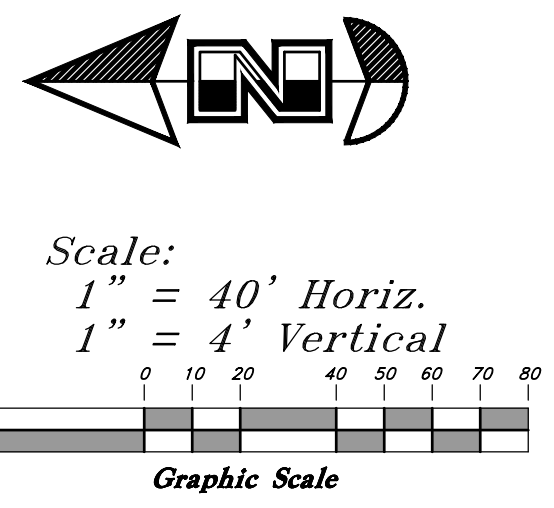
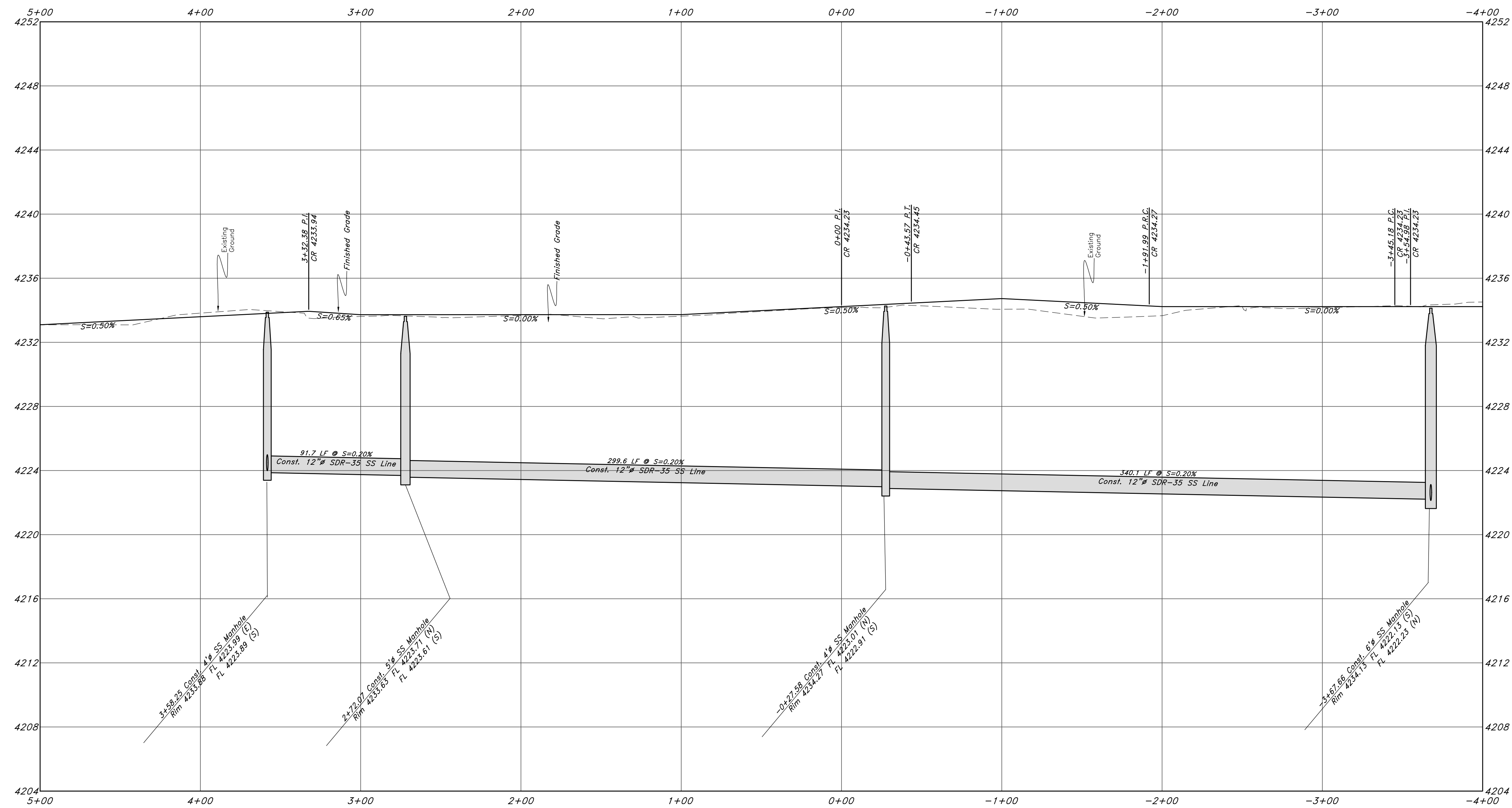

REV	DATE	DESCRIPTION
06-02-2022	06-02-2022	Don White Culinary Water Comments
06-02-2022	06-02-2022	REVISION

GREAT BASIN ENGINEERING

574 SOUTH 1475 EAST BOULEVARD, UTAH 84403
 801.394.4455
 WWW.GREATBASINENGINEERING.COM

Plan & Profile

Terakee Farm PRUD No. 1

Approximately 1000 North 3600 West
 Weber County, Utah
 A part of Section 9, T6N, R2W, SLB&M, U.S. Survey

May, 2022

SHEET NO.

C1

of 7

CONSTRUCTION SITE



Legend

(Note: All items may not appear on drawing)

- San. Sewer Manhole
- Water Manhole
- Storm Drain Manhole
- Cleanout
- Electrical Manhole
- Catch Basins
- Exist. Fire Hydrant
- Fire Hydrant
- Exist. Water Valve
- Water Valve
- Sanitary Sewer
- Culinary Water
- Gas Line
- Irrigation Line
- Storm Drain
- Telephone Line
- Secondary Waterline
- Power Line
- Fire Line
- Land Drain
- Power pole
- Power pole w/guy
- Light Pole
- Fence
- Flowline of ditch
- Overhead Power line
- Corrugated Metal Pipe
- Concrete Pipe
- Reinforced Concrete Pipe
- Ductile Iron
- Polyvinyl Chloride
- Top of Asphalt
- Edge of Asphalt
- Centerline
- Flowline
- Finish Floor
- Top of Curb
- Top of Wall
- Top of Walk
- TCN
- Natural Ground
- Finish Grade
- ME
- Match Existing
- Fire Department Connection
- Finish Contour
- Exist. Contour
- Finish Grade
- Exist. Grade
- Ridge Line

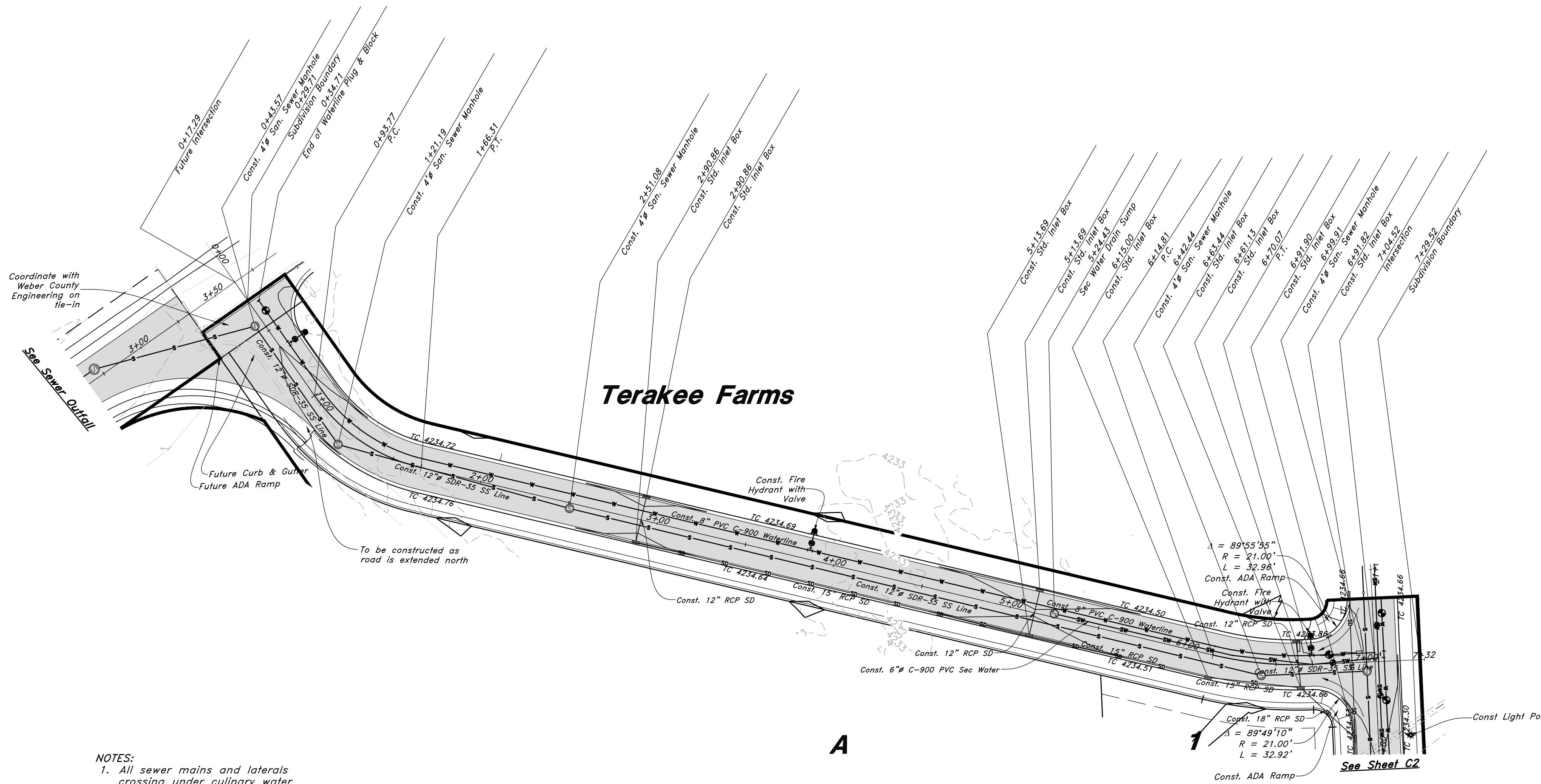

NOTES:
 1. All sewer mains and laterals crossing under culinary water with less than 18" of clearance shall be sleeved per TWW standard drawings.

Terakee Drive (3575 West Street)

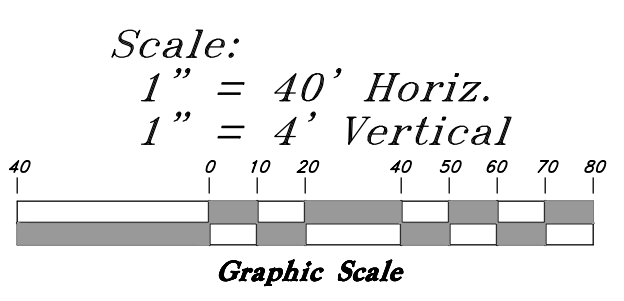
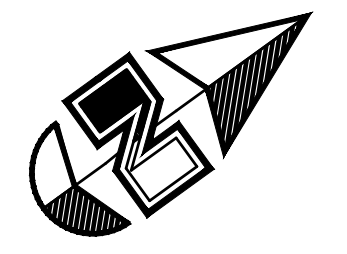
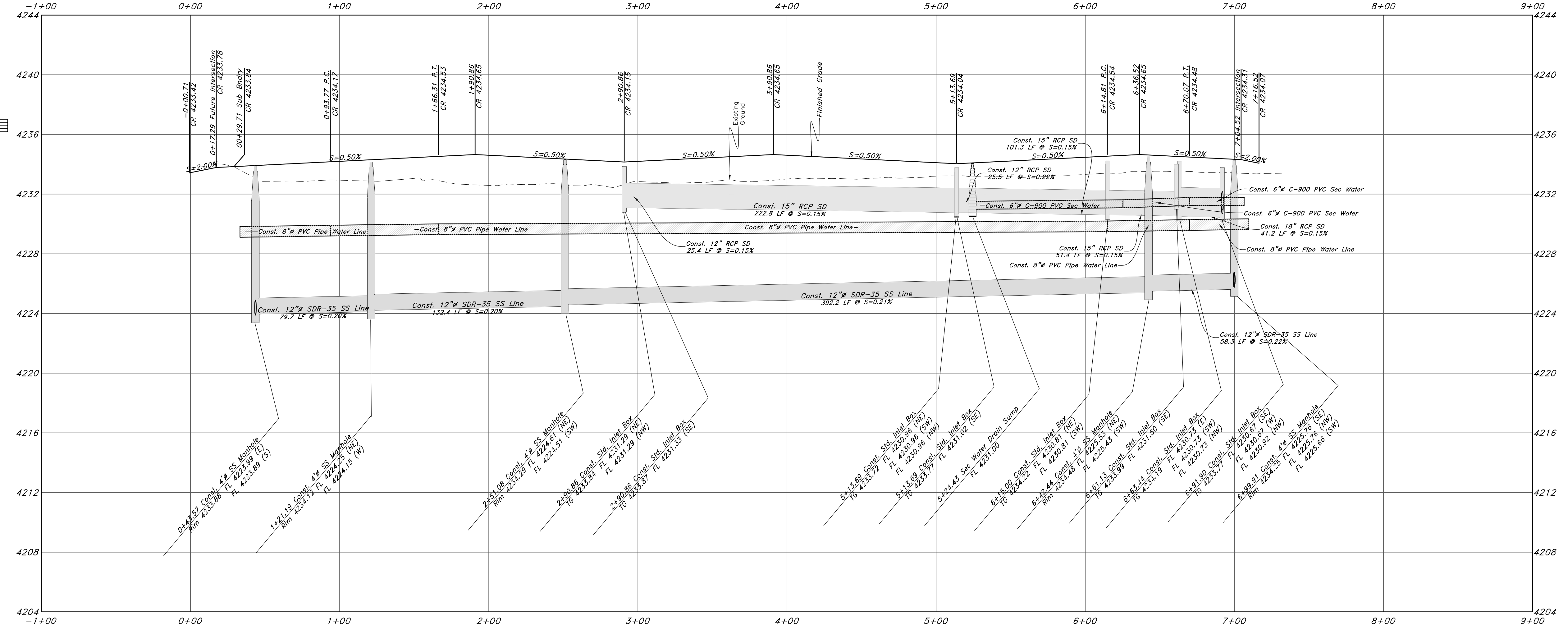

GREAT BASIN ENGINEERING
 574 SOUTH 1475 EAST, BODEN, UTAH 84403
 WWW.GREATBASINENGINEERING.COM

Plan & Profile
Terakee Farm PRUD No. 1
 Approximately 1000 North 3600 West
 Weber County, Utah
 A part of Section 9, T6N, R2W, SLB&M, U.S. Survey

Call before you Dig
 Avoid cutting underground utility lines. It's costly.

1-800-862-4111

May, 2022
 SHEET NO.
C1
 of 7
 16N704 - AM-1

Legend

(Note: All items may not appear on drawing)

- San. Sewer Manhole
- Water Manhole
- Storm Drain Manhole
- Cleanout
- Electrical Manhole
- Catch Basins
- Exist. Fire Hydrant
- Exist. Water Valve
- Sanitary Sewer
- Culinary Water
- Gas Line
- Irrigation Line
- Storm Drain
- Telephone Line
- Secondary Waterline
- Power Line
- Fire Line
- Land Drain
- Power pole
- Power pole w/guy
- Light Pole
- Fence
- Flowline of ditch
- Overhead Power line
- Corrugated Metal Pipe
- Concrete Pipe
- Reinforced Concrete Pipe
- Ductile Iron
- Polyvinyl Chloride
- Top of Asphalt
- Edge of Asphalt
- Centerline
- Flowline
- Finish Floor
- Top of Curb
- Top of Wall
- Top of Walk
- Top of Concrete
- Natural Ground
- Finish Grade
- Match Existing
- Fire Department Connection
- Finish Contour
- Exist. Contour
- Finish Grade
- Exist. Grade
- Ridge Line

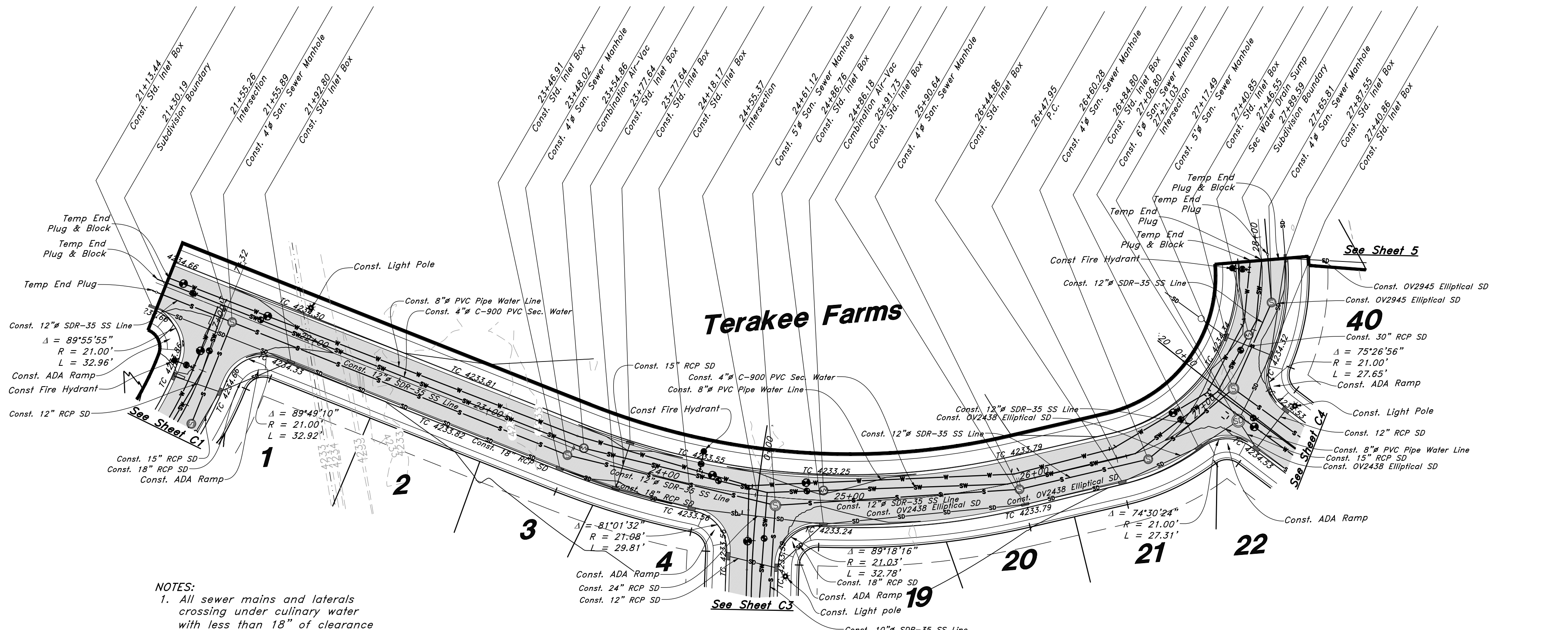

NOTES:
 1. All sewer mains and laterals crossing under culinary water with less than 18" of clearance shall be sleeved per TWW standard drawings.

500 North Street

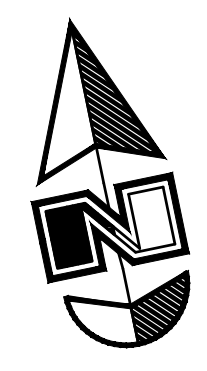
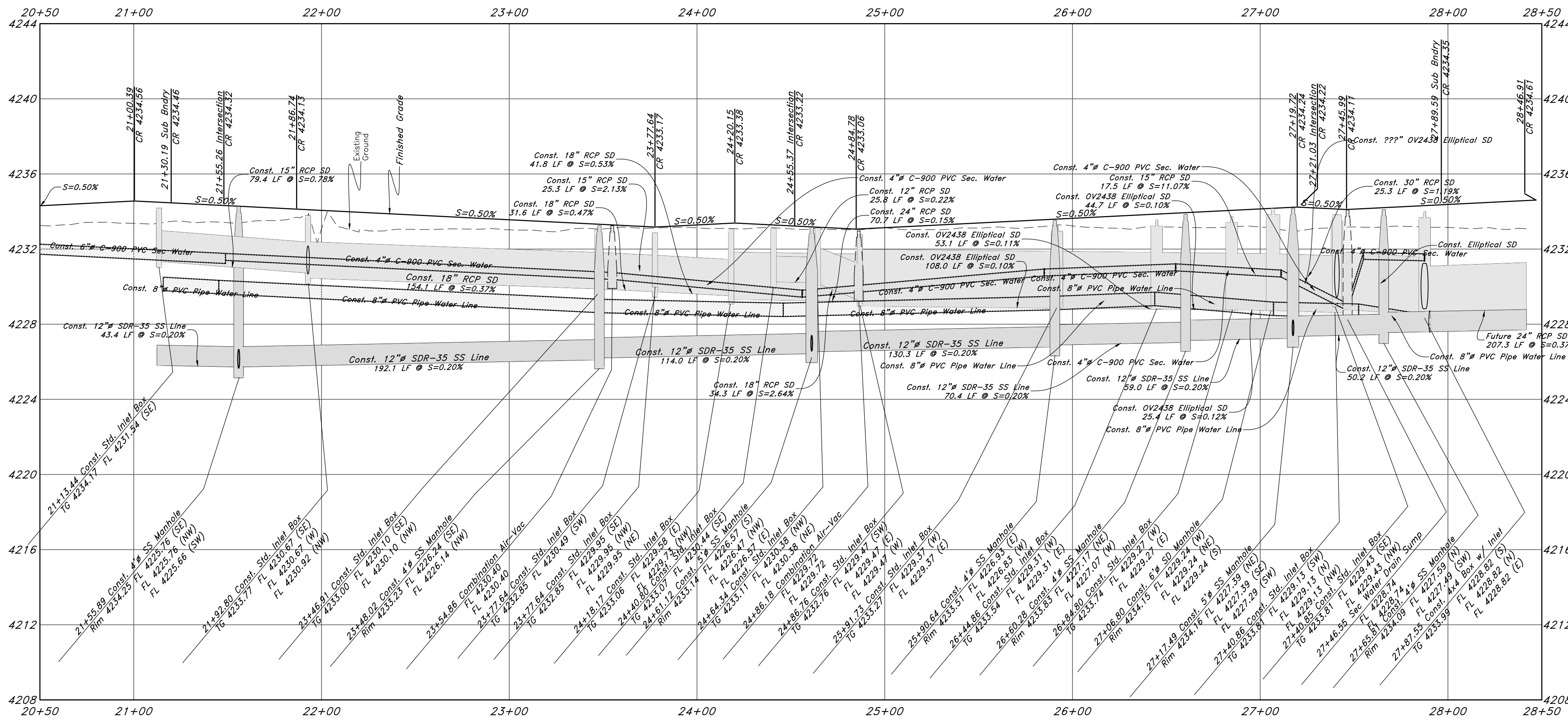

Scale:
 1" = 40' Horiz.
 1" = 4' Vertical

Graphic Scale

GREAT BASIN ENGINEERING
 5740 BUTTE BLVD. SUITE 100, BOULDER, UTAH 84403
 WWW.GREATBASINENGINEERING.COM

Plan & Profile
Terakee Farm PRUD No. 1
 Approximately 1000 North 3600 West
 Weber County, Utah
 A part of Section 9, T6N, R2W, SLB&M, U.S. Survey

May, 2022
 SHEET NO.
G2
 of 7
 16N704 - AM-1

CONSTRUCTION SERVICES
 Call before you Dig
 Avoid cutting underground utility lines
 Call 811
 1-800-662-4111

Legend

(Note: All items may not appear on drawing)

- San. Sewer Manhole
- Water Manhole
- Storm Drain Manhole
- Cleanout
- Electrical Manhole
- Catch Basins
- Exist. Fire Hydrant
- Fire Hydrant
- Exist. Water Valve
- Water Valve
- Sanitary Sewer
- Culinary Water
- Gas Line
- Irrigation Line
- Storm Drain
- Telephone Line
- Secondary Waterline
- Power Line
- Fire Line
- Land Drain
- Power pole w/guy
- Light Pole
- Fence
- Flowline of ditch
- Overhead Power line
- Corrugated Metal Pipe
- Concrete Pipe
- Reinforced Concrete Pipe
- RCP
- Ductile Iron
- Polyvinyl Chloride
- Top of Asphalt
- Edge of Asphalt
- Centerline
- Flowline
- Finish Floor
- Top of Curb
- Top of Wall
- Top of Walk
- Top of Concrete
- Natural Ground
- Finish Grade
- Match Existing
- Fire Department Connection
- Finish Contour
- Exist. Contour
- Finish Grade
- Exist. Grade
- Ridge Line
- Existing Asphalt
- New Asphalt
- Heavy Duty Asphalt
- Existing Concrete
- New Concrete
- Spill Curb & Gutter
- Existing Gravel

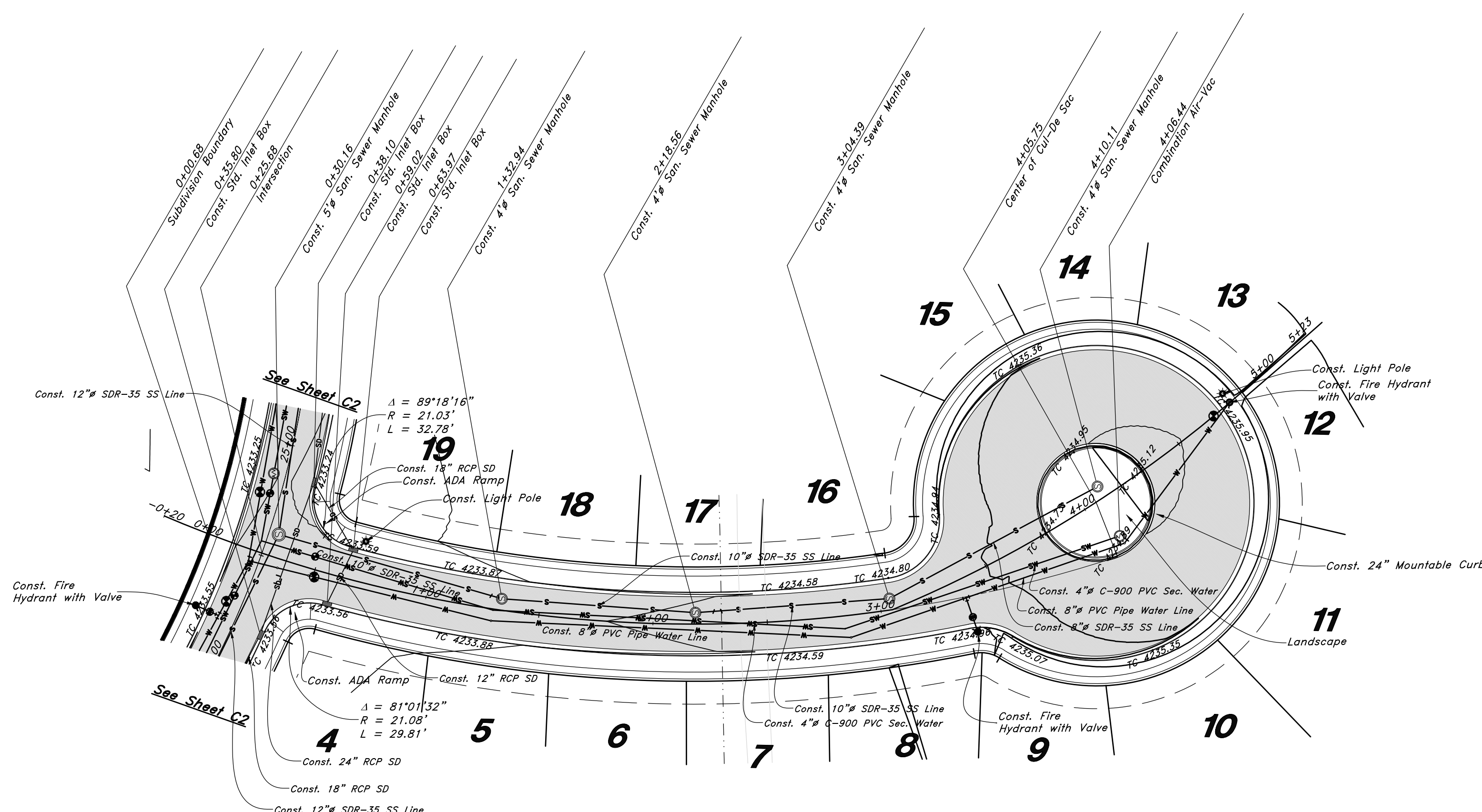

3525 West Street

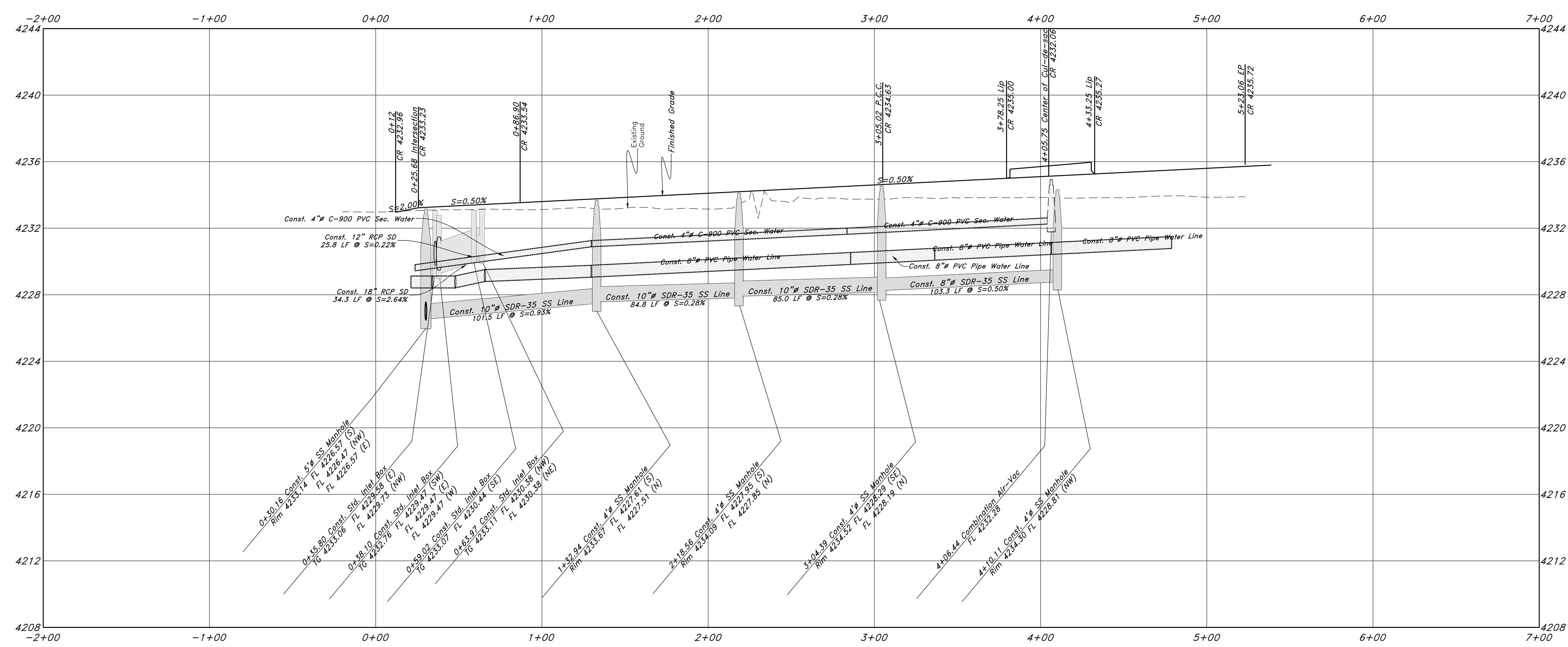

Call before you Dig
Avoid cutting underground utility lines. It's costly.



CONSTRUCTION SERVICES

REV	DATE	DESCRIPTION
01	06-02-2022	Don White Culinary Water Comments
02		RESUBMITTAL

GREAT BASIN ENGINEERING

574 SOUTH 1475 EAST, BOULEVARD, UTAH 84403
 1100 SOUTH 4400 WEST, SUITE 100, SALT LAKE CITY, UTAH 84119
 WWW.GREATBASINENGINEERING.COM

Plan & Profile

Terakee Farm PRUD No. 1

Approximately 1000 North 3600 West
 Weber County, Utah

A part of Section 9, T6N, R2W, SLB&M, U.S. Survey

May, 2022

SHEET NO. **C3** of 7

16N704 - AM-1

Legend

(Note: All items may not appear on drawing)

- San. Sewer Manhole
- Water Manhole
- Storm Drain Manhole
- Cleanout
- Electrical Manhole
- Catch Basins
- Exist. Fire Hydrant
- Fire Hydrant
- Exist. Water Valve
- Water Valve
- Sanitary Sewer
- Culinary Water
- Gas Line
- Irrigation Line
- Storm Drain
- Telephone Line
- Secondary Waterline
- Power Line
- Fire Line
- Land Drain
- Power pole
- Power pole w/guy
- Light Pole
- Fence
- Flowline of ditch
- Overhead Power line
- Corrugated Metal Pipe
- Concrete Pipe
- Reinforced Concrete Pipe
- Ductile Iron
- Polyvinyl Chloride
- Top of Asphalt
- Edge of Asphalt
- Centerline
- Flowline
- Finish Floor
- Top of Curb
- Top of Wall
- Top of Walk
- Top of Concrete
- Natural Ground
- Finish Grade
- Match Existing
- Fire Department Connection
- Finish Contour
- Exist. Contour
- Finish Grade
- Exist. Grade
- Ridge Line
- Existing Asphalt
- New Asphalt
- Heavy Duty Asphalt
- Existing Concrete
- New Concrete
- Spill Curb & Gutter
- Existing Gravel

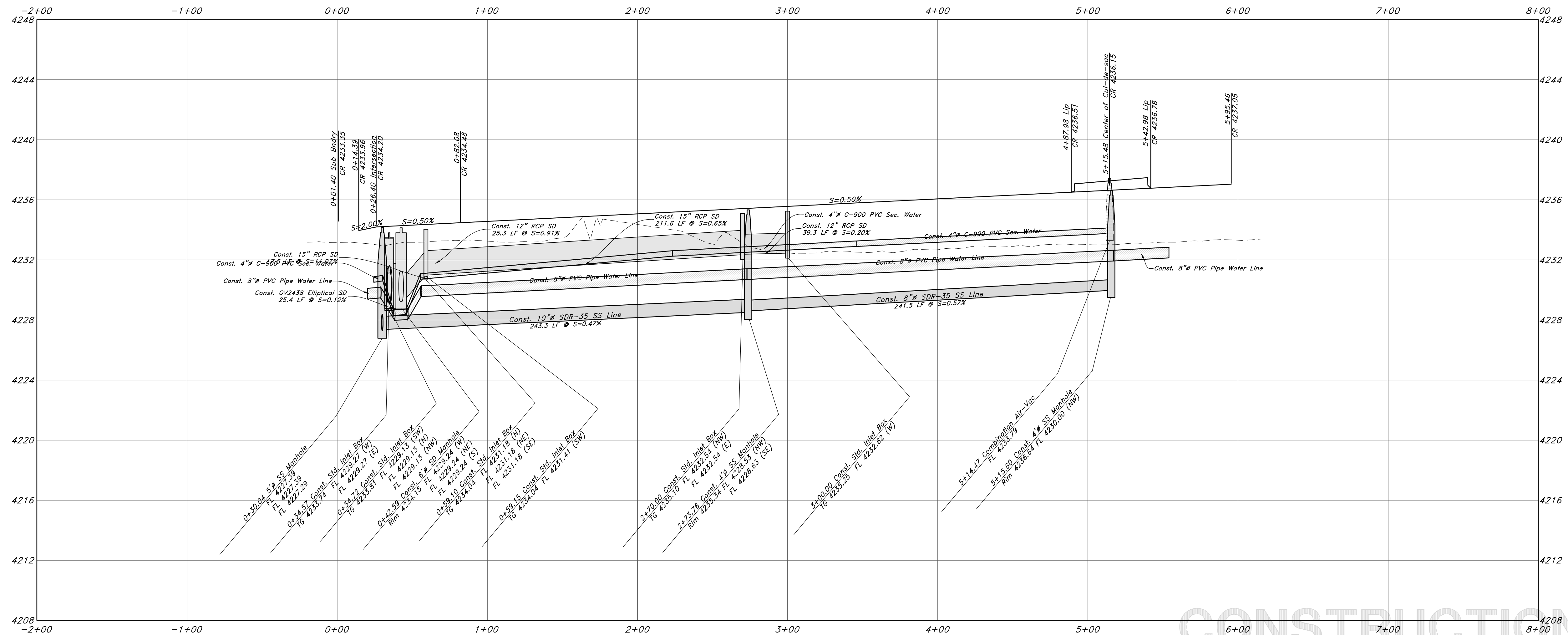
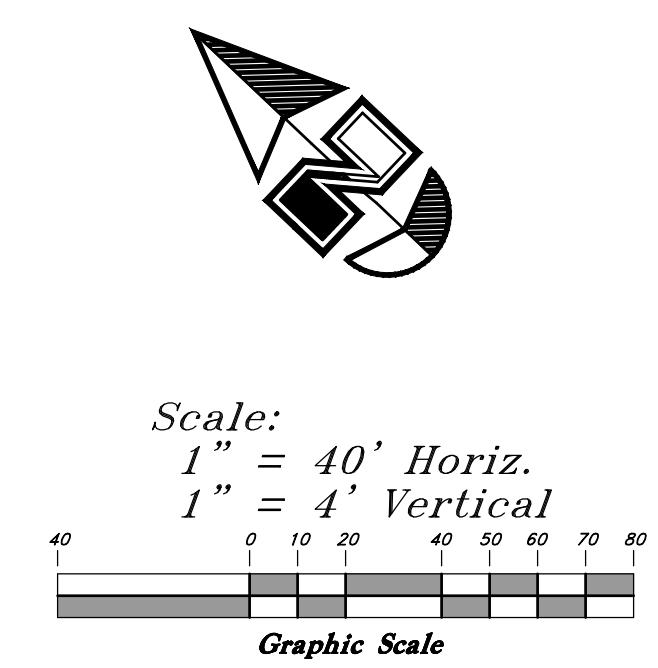
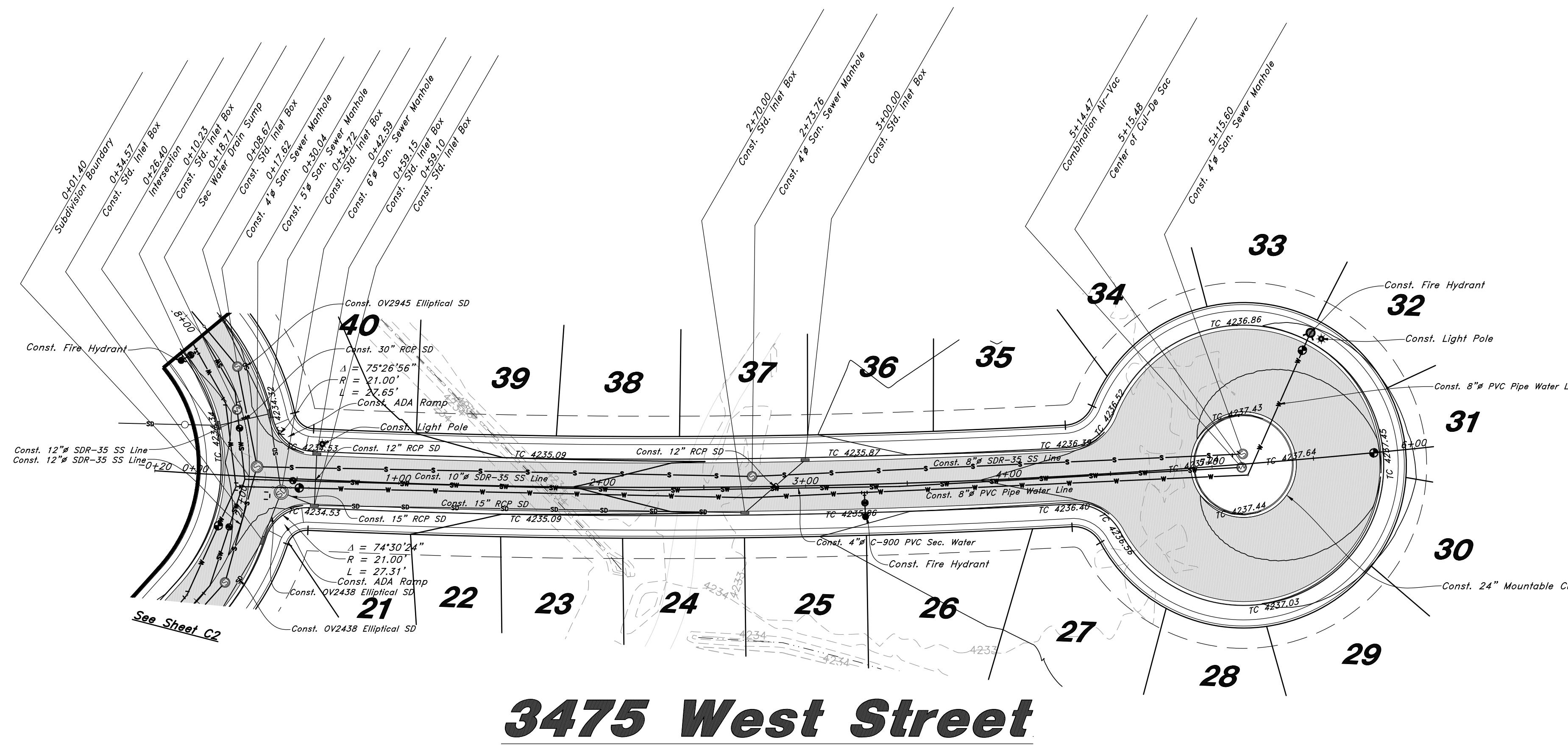

GREAT BASIN ENGINEERING
 574 SOUTH 1475 EAST, SUITE 100, OGDEN, UTAH 84403
 WWW.GREATBASINENGINEERING.COM

Plan & Profile
Terakee Farm PRUD No. 1
 Approximately 1000 North 3600 West
 Weber County, Utah
 A part of Section 9, T6N, R2W, SLB&M, U.S. Survey



CONSTRUCTION SITE

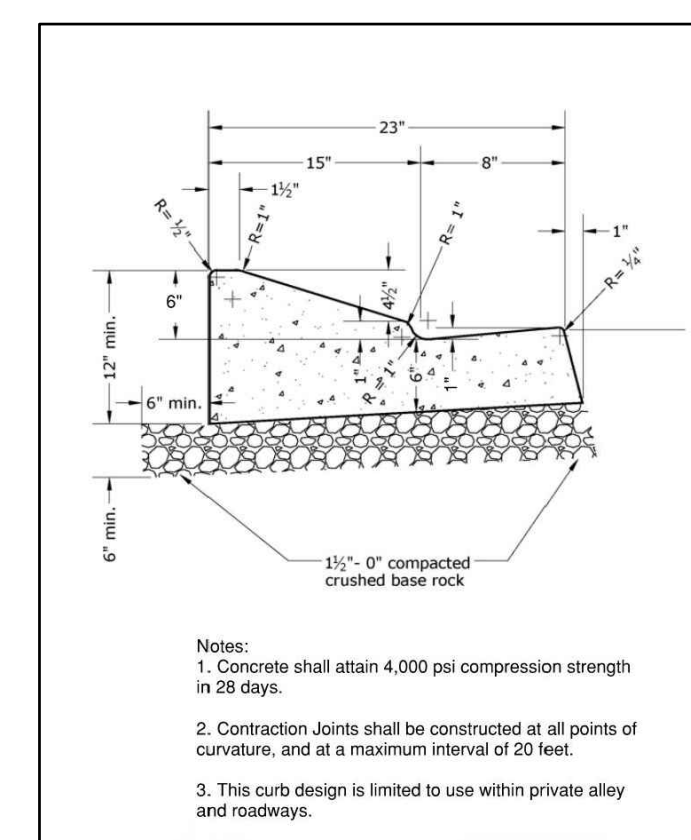
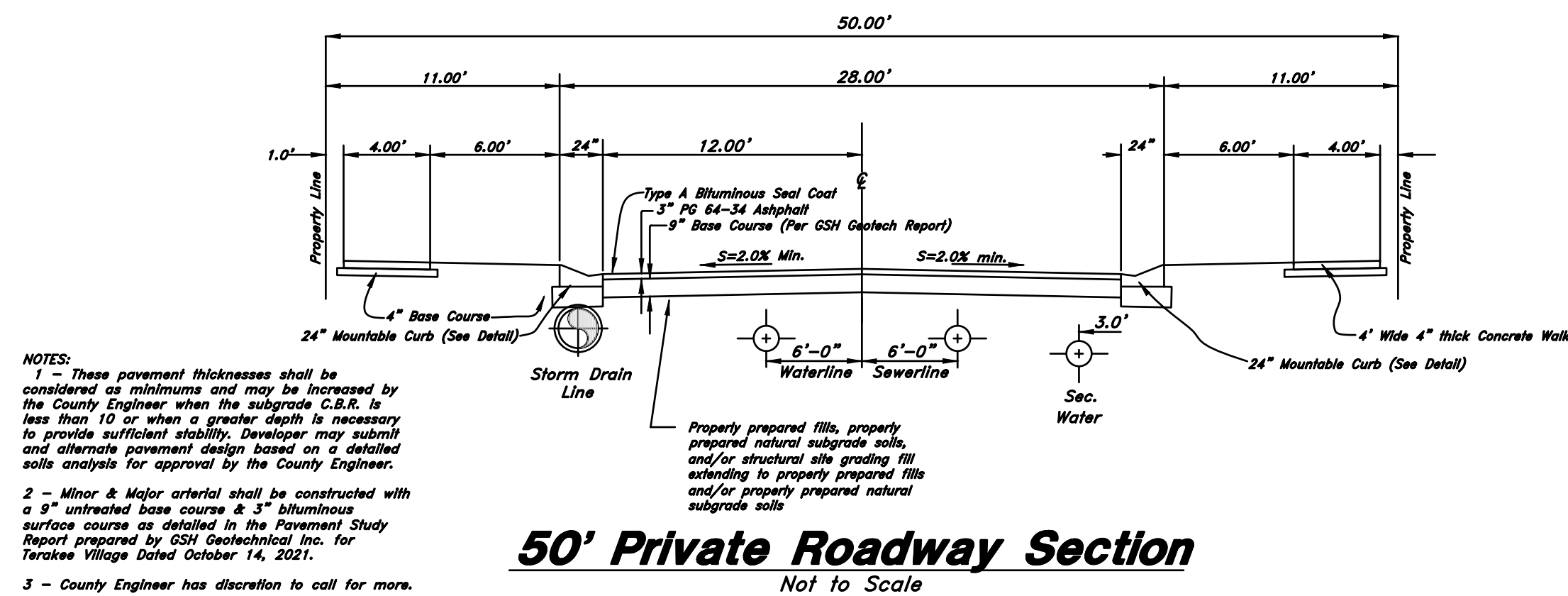
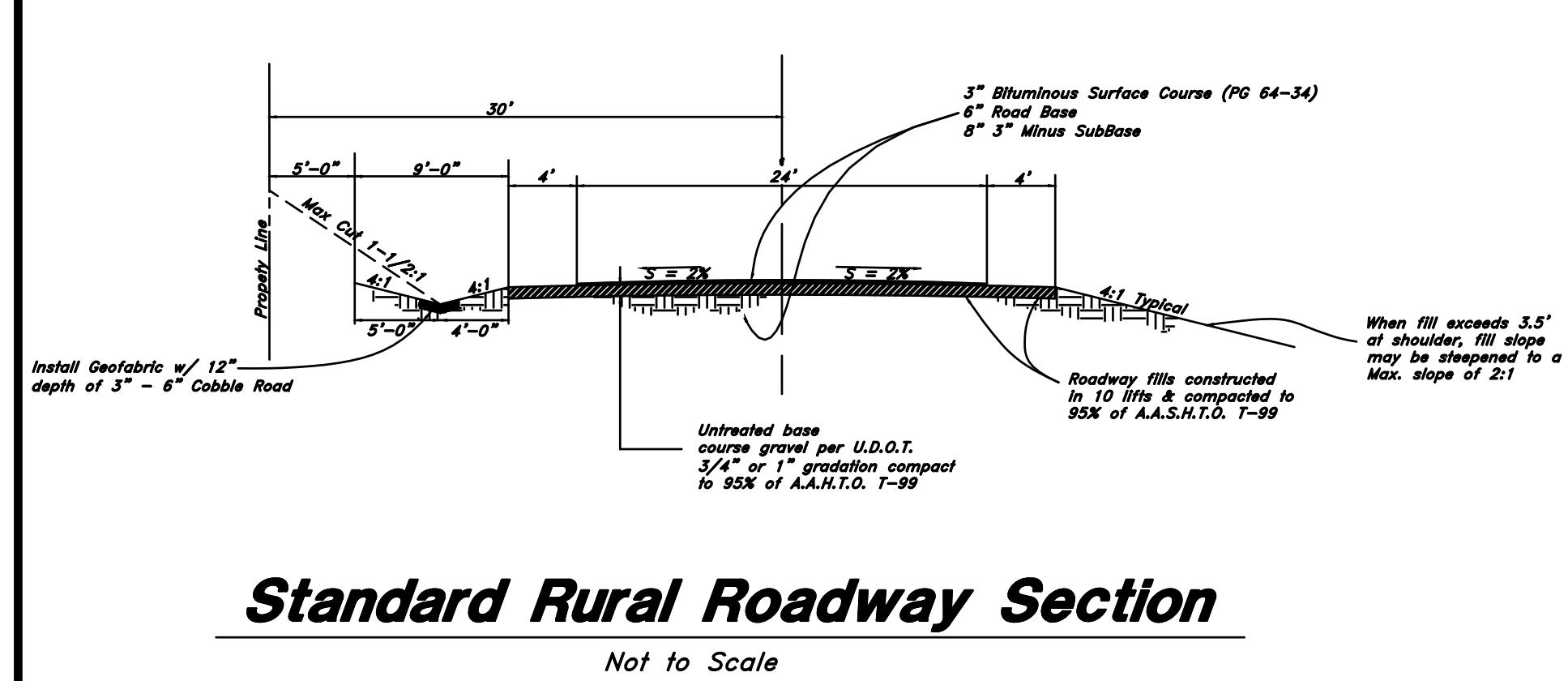
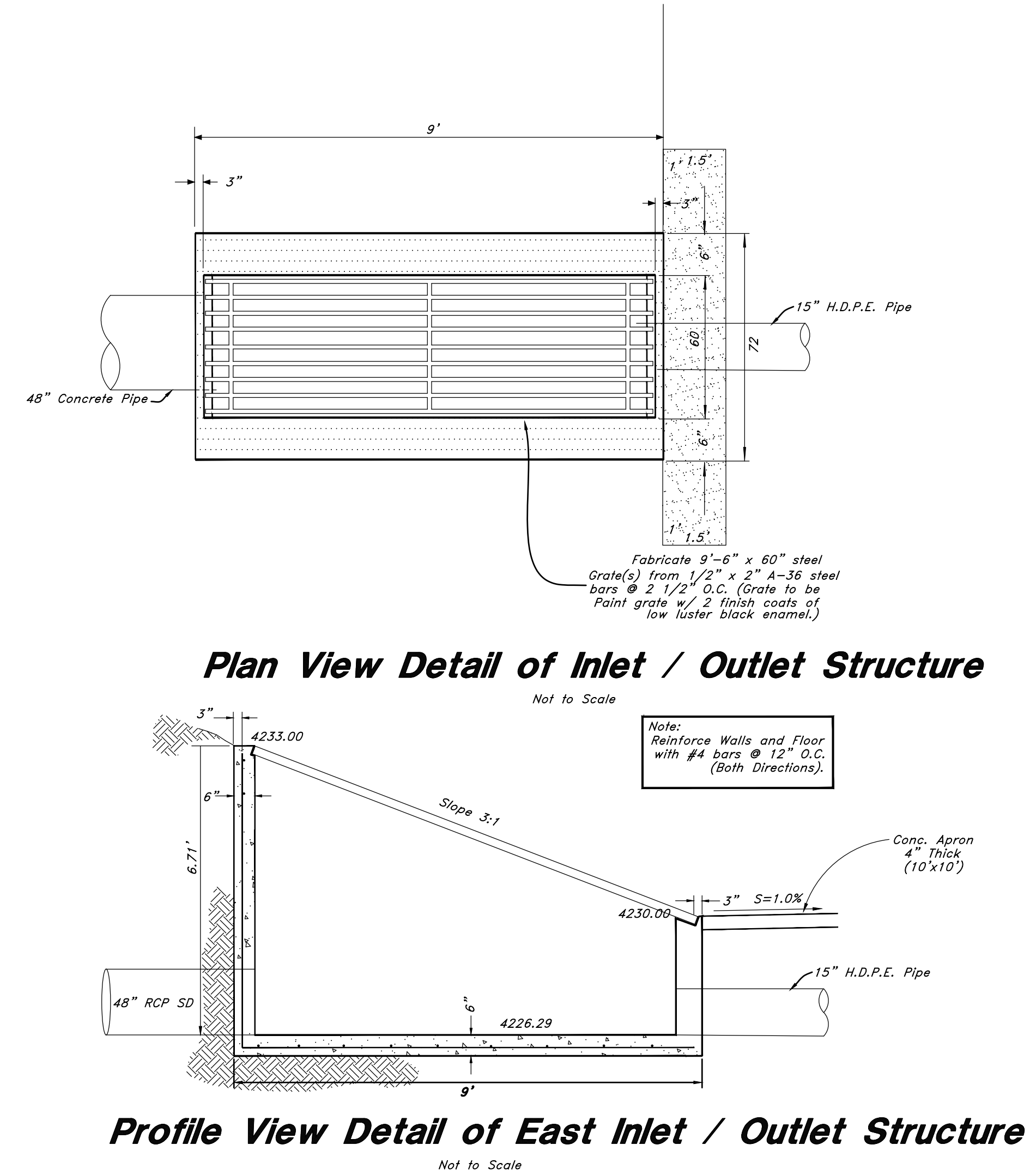
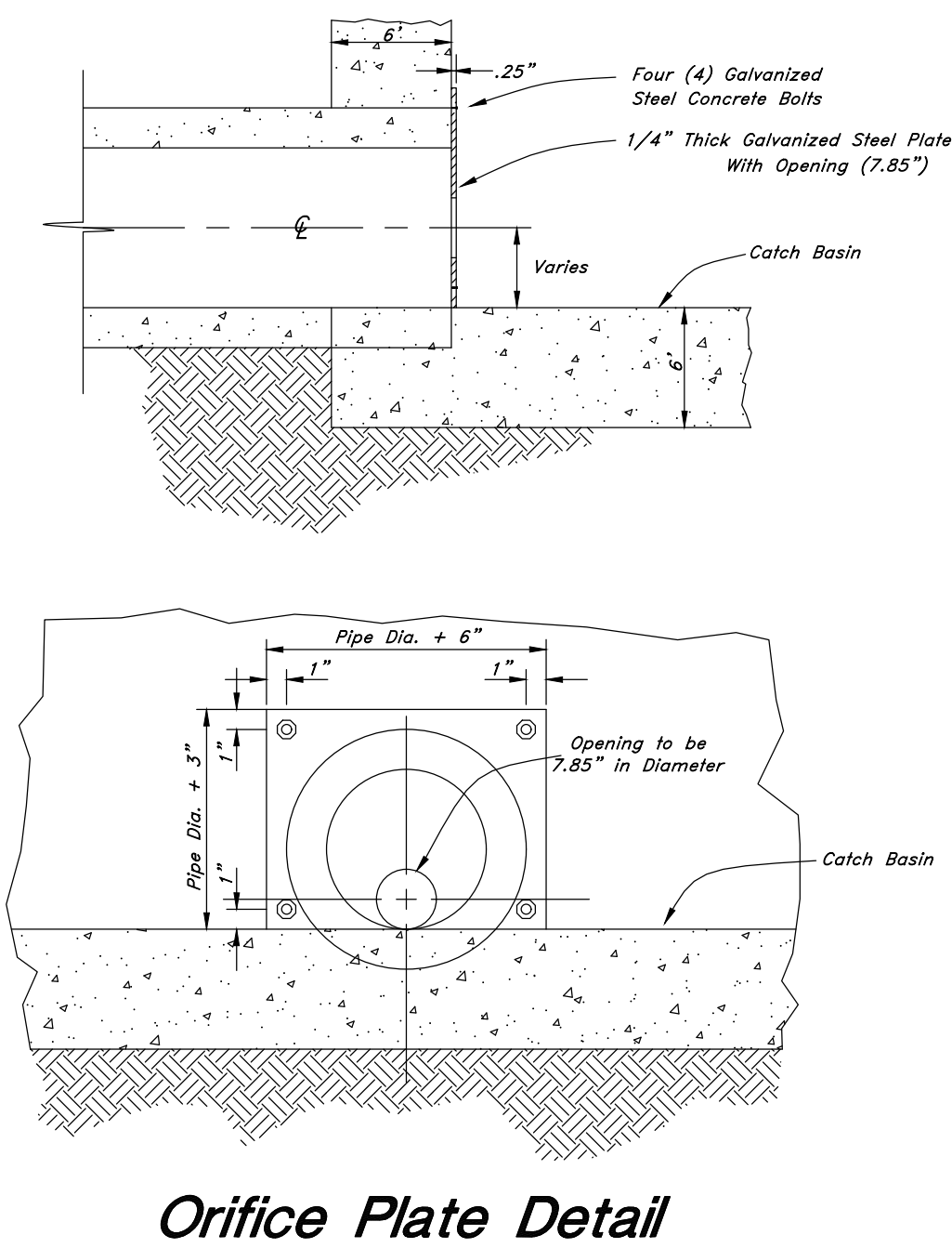
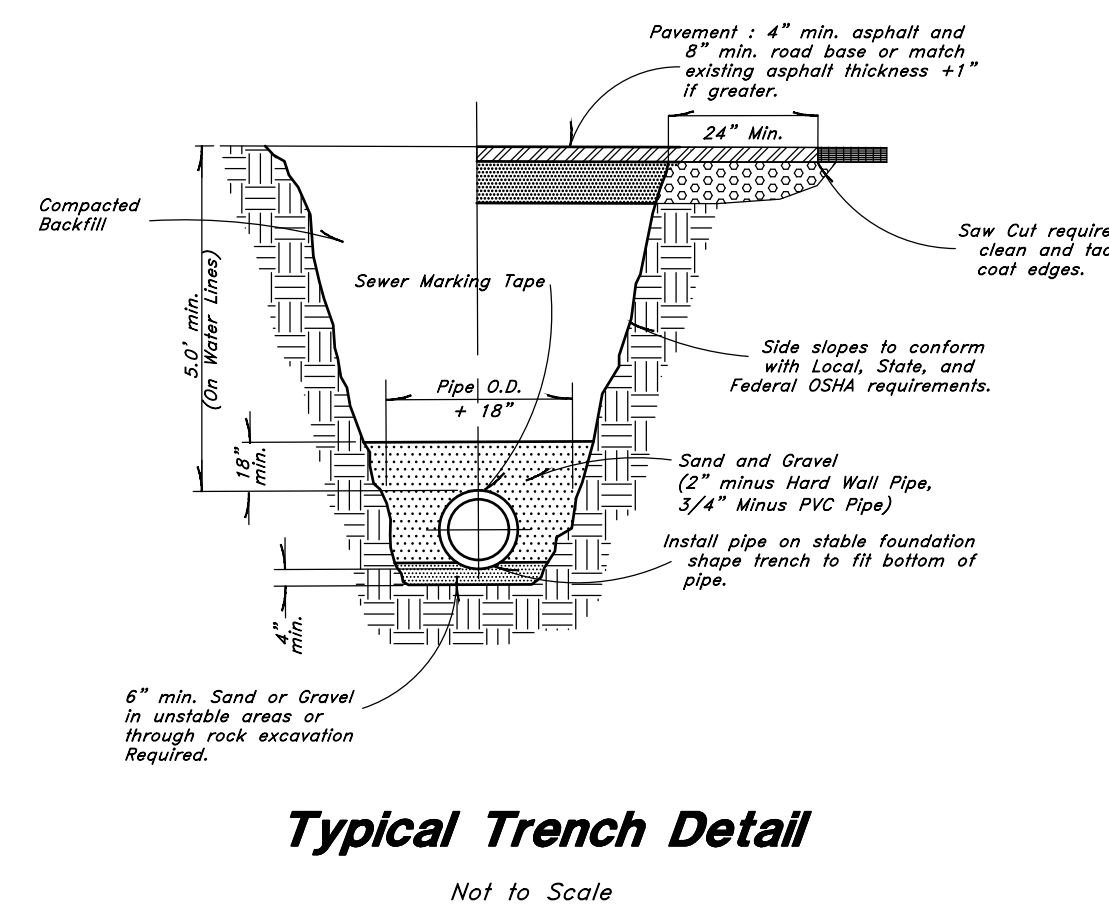
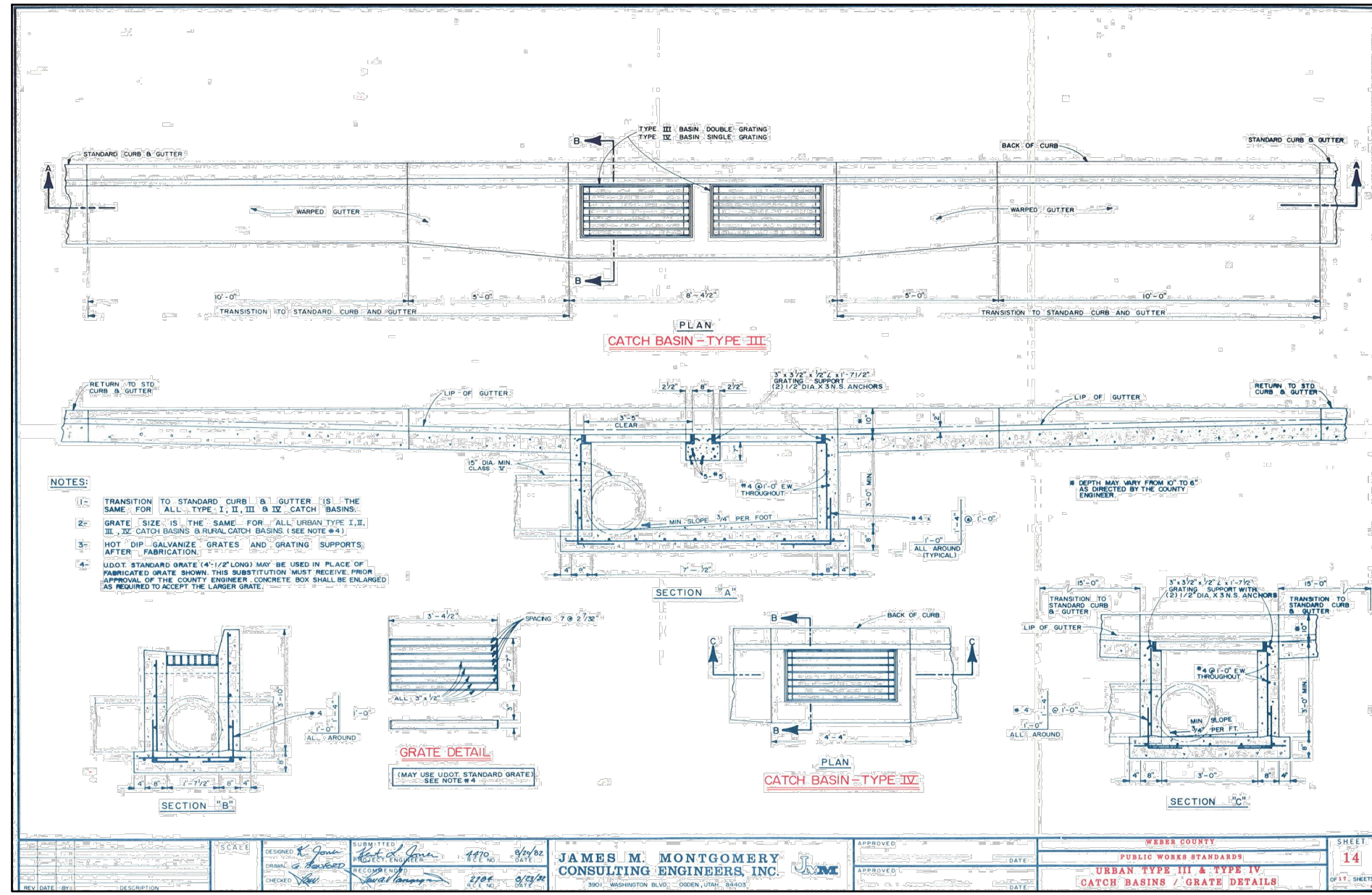

Call before you Dig

Avoid cutting underground utility lines. It's costly.

Call 811

1-800-662-4111

GREAT BASIN ENGINEERING

574 SOUTH 1475 EAST, SUITE 100, OGDEN, UTAH 84403

WWW.GREATBASINENGINEERING.COM

Details

Terakee Farm PRUD No. 1

Approximately 1000 North 3600 West

Weber County, Utah

A part of Section 9, T6N, R2W, SLB&M, U.S. Survey

10 Nov, 2021

SHEET NO.

G5

of 7

16N704 - AM-1

REV 08-02-2022 Don White Utility Water Comments

REV 08-02-2022 ZB

* See All Sheets*

Terakee Farm® PRUD No. 1

A PRUD Subdivision

A part of Section 9, T6N, R2W, SLB&M, U.S. Survey
Weber County, Utah
May 2022

GENERAL GRADING NOTES:

- All work shall be in accordance with the County Public Works Standard.
- Cut slopes shall be no steeper than 2 horizontal to 1 vertical.
- Fill slopes shall be no steeper than 2 horizontal to 1 vertical.
- Fills shall be compacted per the recommendations of the geotechnical report prepared for the project and shall be certified by the geotechnical engineer.
- Areas to receive fill shall be properly prepared and approved by the County inspector and geotechnical Engineer prior to placing fill.
- Fills shall be benched into competent material as per specifications and geotechnical report.
- All trench backfill shall be tested and certified by the site geotechnical engineer per the grading code.
- A geotechnical engineer shall perform periodic inspections and submit a complete report and map upon completion of the rough grading.
- The final compaction report and certification from the geotechnical engineer shall contain the type of field testing performed. Each test shall be identified with the method of obtaining the in-place density, whether sand cone or drive ring and shall be so noted for each test. Sufficient maximum density determinations shall be performed to verify the accuracy of the maximum density curves used by the field technician.
- Dust shall be controlled by watering.
- The location and protection of all utilities is the responsibility of the permittee.
- Approved protective measures and temporary drainage provisions must be used to protect adjoining properties during the grading project.
- All public roadways must be cleared daily of all dirt, mud and debris deposited on them as a result of the grading operation. Cleaning is to be done to the satisfaction of the city engineer.
- The site shall be cleared and grubbed of all vegetation and deleterious matter prior to grading.
- The contractor shall provide shoring in accordance with OSHA requirements for trench walls.
- Aggregate base shall be compacted per the geotechnical report prepared for the project.
- Elevations shown on this plan are finish grades. Rough grades are the subgrades of the improvements shown hereon.
- The recommendations in the following Geotechnical Engineering Report by GSI Geotechnical, Inc are included in the requirements of grading and site preparation.
The report is titled "GEOTECHNICAL STUDY"
Job No.: 3374-001-21
Dated: September 9, 2021
- As part of the construction documents, owner has provided contractor with a topographic survey performed by manual or aerial means. Such survey was prepared for project design purposes and is provided to the contractor as a courtesy. It is expressly understood that such survey may not accurately reflect existing topographic conditions.
- Erosion Control: Protect all inlet boxes, catch basins, etc. with straw bales or other approved method to strain the storm water during construction. Protect surrounding properties and streets from site runoff with sandbags and earth berms.

NOTES

- All construction shall conform to Weber County standards and specifications.
- All Construction on the Secondary Water Line shall meet or exceed Marriott-Stalerville Standards and Specifications.
- Underground utility piping materials will meet or exceed Weber County Standards.
- Culinary water services will be 3/4" Dia. C-900 DR14 PVC to be centered on the frontage and extended 10' beyond the right of way line.
- 4" Sanitary sewer laterals to be constructed 10' down slope from the center of the lot and extended 10' beyond the right of way line.
- 4" Land drain laterals to be constructed at the low corner of the lot and extended 10' beyond the right of way line.
- Saw Cut Existing Asphalt to provide a smooth clean edge.
- All Utility trenches within the Street right of way shall have a City approved imported granular backfill.
- Thrust block all water line fittings.
- All inlet grates shall be bicycle safe.
- All fire hydrants and access roads shall be installed prior to any construction of any buildings.
- All fire hydrants shall be placed with 4 1/2 inch connections facing the point of access for the Fire Department Apparatus.
- Prior to the beginning of construction of any buildings, a fire flow test of new hydrants shall be conducted to verify the actual fire flow for this project. The Fire Prevention Division shall witness this test and shall be notified a minimum of 48 hours prior to the test.
- Curb & gutter installed along 2200 South Street will be set to ensure a 1.5% minimum/3.0% Maximum cross slope from edge of asphalt. Contractor to verify prior to construction of curb.
- An excavation permit is required for all work done within the existing Right of Way.
- A Storm Water Construction Activity Permit is required for any construction that disturbs more than 5000 Sq. Ft. or 200 Cubic Yards.
- All Improvements need to be either installed or escrowed prior to recording of the subdivision.
- If construction activity will disturb more than an acre then a State SWPPP will be required. This includes the construction of the homes etc. on each lot.

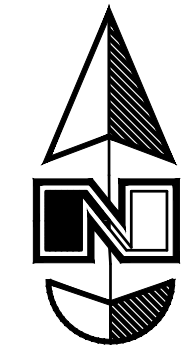

Terakee Farm®

Scale: 1" = 60'

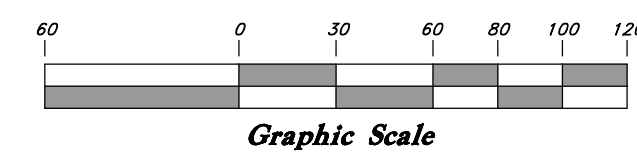

McFarland Subdivision

Terakee Farm®

GENERAL UTILITY NOTES:

- Coordinate all utility connections to building with plumbing plans and building contractor.
- Verify depth and location of all existing utilities prior to constructing any new utility lines. Notify Civil Engineer of any discrepancies or conflicts prior to any connections being made.
- All catch basin and inlet box grates are to be bicycle proof.
- All inlet boxes located in curb and gutter are to be placed parallel to the curb and gutter and set under the frame and grate. Improperly placed boxes will be removed and replaced at no additional cost to the owner. Precast or cast in place boxes are acceptable.
- Refer to the site electrical plan for details and locations of electrical lines, transformers and light poles.
- Gas lines, telephone lines, and cable TV lines are not a part of these plans unless otherwise noted.
- Water meters are to be installed per city standards and specifications. It will be the contractor's responsibility to install all items required.
- Water lines, valves, fire hydrants, fittings etc. are to be constructed as shown. Contractor is responsible to construct any vertical adjustments necessary to clear sewer, storm drain or other utilities as necessary including valve boxes and hydrant spools to proper grade.
- Field verify all existing and/or proposed Roof Drain/Roof Drain down spout connections to Storm Water System with Civil, Plumbing & Architectural plans. Notify Engineer of any discrepancies.
- All gravity flow utility lines shall be installed prior to any pressurized utilities unless written permission is obtained from the engineer of record before construction begins.

UTILITY PIPING MATERIALS:

All piping to be installed per manufacturers recommendations. Refer to project specifications for more detailed information regarding materials, installation, etc.

CULINARY SERVICE LATERALS

- 3/4" to 2" diameter pipe - CTS 150 Poly Pipe
- Over 2" diameter pipe - AWWA C-900 Class 150 pipe

WATER MAIN LINES AND FIRE LINES

- Pipe material as shown on utility plan view or to meet city standards.

SANITARY SEWER LINES

- All sewer piping to be Polyvinyl Chloride (PVC) sewer pipe, ASTM D 3034, Type PSM, SDR 35

STORM DRAIN LINES

- 10" pipes or smaller - Polyvinyl Chloride (PVC) sewer pipe, ASTM D3034, Type PSM, SDR 35
- 12" to 21" pipes - Concrete Pipe, ASTM C14, Class III up to 13' of cover. For greater than 13' feet of cover, use reinforced concrete pipe and classes listed below.
- 24" pipes or larger - Reinforced Concrete Pipe, ASTM C76, Class III up to 13' of cover, Class IV for 13' to 21' of cover, Class V for 21' to 32' of cover, and Special Design for cover greater than 32 feet.

CURB AND GUTTER CONSTRUCTION NOTES:

- Open face gutter shall be constructed where drainage is directed away from curb.
- Open face gutter locations are indicated by shading and notes on site and grading plan.
- It is the responsibility of the surveyor to adjust top of curb grades at the time construction staking.
- Refer to the typical details for a standard and open face curb and gutter for dimensions.
- Transitions between open face and standard curb and gutter are to be smooth. Hand form these areas if necessary.

ADA NOTES:

Contractor must maintain a running slope on Accessible routes no steeper than 5.0% (1:20). The cross slope for Accessible routes must be no steeper than 2.0% (1:50). All Accessible routes must have a minimum clear width of 36". If grades on plans do not meet this requirement notify Consultants immediately.
The Client, Contractor, and Subcontractor should immediately notify the Consultant of any conditions of the project that they believe do not comply with the current state of the ADA and/or FHAA.

CAUTION NOTICE TO CONTRACTOR
The contractor is specifically cautioned that the location and/or elevation of existing utilities as shown on these plans are based on records of the various utility companies and, where possible, measurements taken in the field. The information is not to be relied on as being exact or complete. The contractor must call the appropriate utility company at least 48 hours before any excavation to request exact field location of utilities. It shall be the responsibility of the contractor to relocate all existing utilities which conflict with the proposed improvements shown on the plans.

PRIVATE ENGINEER'S NOTICE TO CONTRACTORS
The Contractor agrees that he shall assume sole and complete responsibility for job site conditions during the course of construction of this project, including safety of all persons and property; that this requirement shall apply continuously and not be limited to normal working hours; and that the contractor shall defend, indemnify, and hold the owner and the engineer harmless from any and all liability, real or alleged, in connection with the performance of work on this project, excepting for liability arising from the sole negligence of the owner or the engineer.

Jed J. & Pamela McCormick

GREAT BASIN ENGINEERING

5746 SOUTH 1475 EAST GARDEN, UTAH 84403
 MAIN (801)394-4515 S.L.C (801)521-0222 FAX (801)392-7544
 WWW.GREATBASINENGINEERING.COM

Grading Plan

Terakee Farm - PRUD No. 1
 Approximately 1000 North, 3600 West
 Weber County, Utah
 A part of Section 9, T6N, R2W, SLB&M, U.S. Survey

10 Nov, 2021

SHEET NO.

C6 of 7

16N704 - AM-1

NOTE:
 WATER MAINS AND SEWER LINES SHALL NOT BE INSTALLED IN THE SAME TRENCH. WHERE LOCAL CONDITIONS MAKE IT IMPOSSIBLE TO INSTALL WATER OR SEWER LINES AT THE SEPARATION DISTANCES SHOWN HERE, AN EXCEPTION TO THE STANDARD MAY BE POSSIBLE. THE ENTITY SEEKING THE EXCEPTION SHALL INITIATE AND PURSUE A REQUEST FOR A SEPARATION EXCEPTION WITH THE STATE DIVISION OF DRINKING WATER, IN ACCORDANCE WITH R309-550-7 OF THE STATE OF UTAH ADMINISTRATIVE RULES.

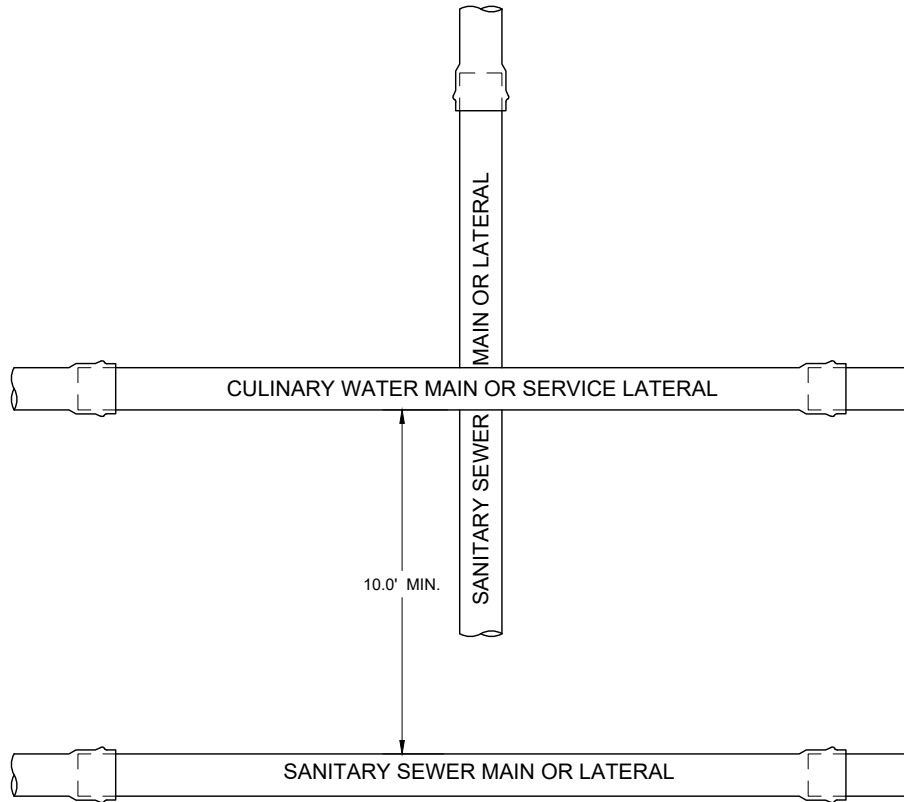

PLAN VIEW

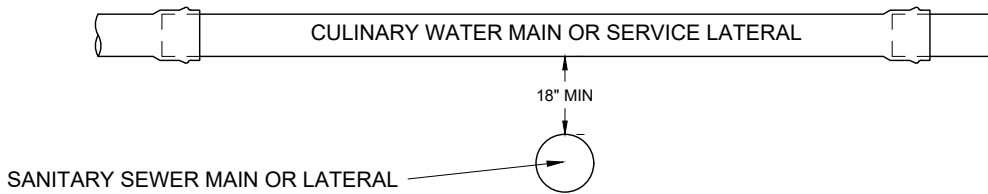

PROFILE VIEW

7 TYPICAL SEWER CROSSING DETAIL

NTS

DRAFTED: MDD	DEVIATIONS FROM STANDARDS MUST BE APPROVED
DESIGNED: DW	BY TAYLOR WEST WEBER WATER IMPROVEMENT
CHECKED: RR	DISTRICT. DDW Approval 6/2020
REV 1:	
REV 2:	
REV 3:	
REV 4:	
r:\2001 - tww\standards\2020\2001-details - rev2022-04-21.dwg	



STANDARD WATER DETAILS
TAYLOR WEST WEBER
WATER IMPROVEMENT DISTRICT

TYPICAL SEWER CROSSING

GARDNER ENGINEERING
 CIVIL • LAND PLANNING
 MUNICIPAL • LAND SURVEYING

5150 SOUTH 375 EAST OGDEN, UT
 OFFICE: 801.476.0202 FAX: 801.476.0066

WATER LATERAL OVER SEWER MAIN

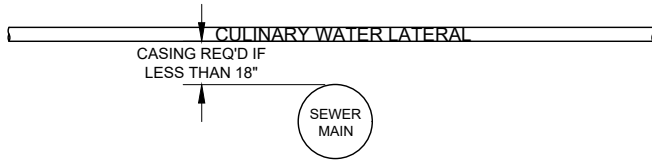

WATER MAIN OVER SEWER LATERAL

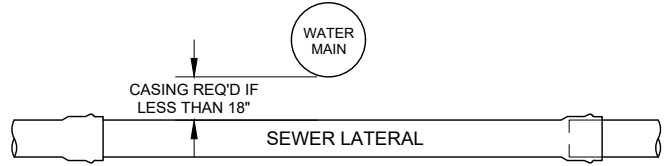

WATER LATERAL UNDER SEWER MAIN

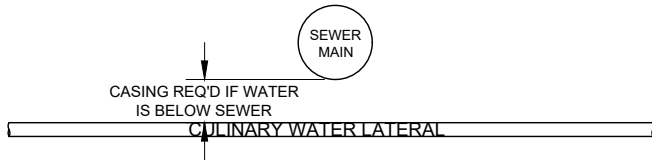

WATER MAIN UNDER SEWER LATERAL

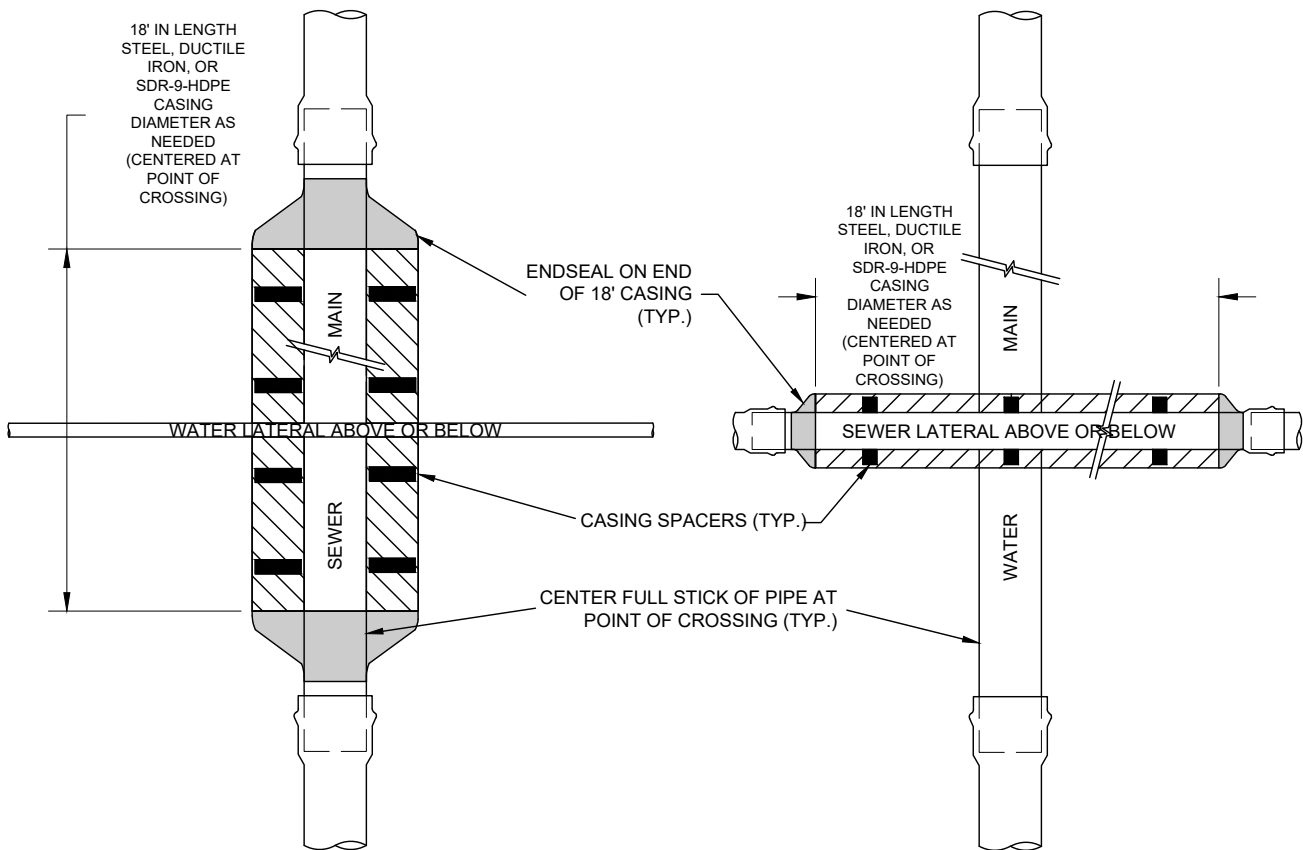
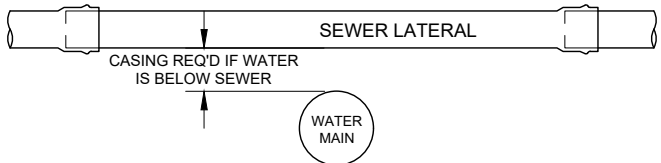

8 SEWER/WATER VERTICAL SEPARATION EXCEPTION DETAIL

NTS

DRAFTED: MDD	DEVIATIONS FROM STANDARDS MUST BE APPROVED BY TAYLOR WEST WEBER WATER IMPROVEMENT DISTRICT. DDW Approval 6/2020
DESIGNED: DW	
CHECKED: RR	
REV 1: 11-12-21	ADDED SEWER/WATER CROSSING
REV 2: 4-21-22	REVISED CASING TO ALWAYS BE ON SEWER LINES
REV 3:	
REV 4:	
r:\2001 - tww\standards\2020\2001-details - rev2022-04-21.dwg	



STANDARD WATER DETAILS
TAYLOR WEST WEBER
WATER IMPROVEMENT DISTRICT
SEWER/WATER CROSSING

GARDNER ENGINEERING
 CIVIL • LAND PLANNING
 MUNICIPAL • LAND SURVEYING
 5150 SOUTH 375 EAST OGDEN, UT
 OFFICE: 801.476.0202 FAX: 801.476.0066