

(This SWPPP Template is for the **Common Plan** Permit Only, and
does **NOT** address SWPPP requirements found in the CGP.)

**Common Plan SWPPP for
Hi-C Construction – Lot 45R Summit at Ski Lake**

6842 E Summit Peak Circle

Huntsville, UT 84317

Hi-C Construction and Design (Owner & Contractor)

7432 E 100 S

Huntsville, UT 84317

Date

5-12-2022

1. Project Information

Project Name: Hi-C Construction Lot 45R Summit at Ski Lake

Address: 7432 E 100 S

City: Huntsville

State: UT

Zip: 84317

Latitude: 41.2434 N

Longitude: 111.7832 W

UPDES Permit Tracking Number: UTRC _____

Owner: Phillip Clawson

Contact Person: Phillip Clawson

Address: 7432 E 100 S

City: Huntsville

State: UT

Zip: 84317

Telephone Number: 801-603-2727

Email Address: office@hi-constructiondesign.com

General Contractor: HI-C Construction and Design

Contact Person: Phillip Clawson

Address: 7432 E 100 S

City: Huntsville

State: UT

Zip: 84317

Telephone Number: 801-603-2727

Email Address: office@hi-constructiondesign.com

Answering "yes" to the question below means the project is not eligible for this permit.

Is the project in Indian Country?

Yes

No

Answering "no" to the question below means the project is not eligible for this permit.

Yes

No

Is the project a residential building on a single lot and disturbing one acre or less?

2. Pollution Sources/Best Management Practices

Answer yes or no whether the following features are located at your site. If yes, select the BMP(s) that will be used to protect each feature. If no, continue to the next question. Attach necessary illustrated details for proper installation in Appendix G, and show locations of all controls on Site Map in Appendix A.

- 2.1 Is there a SWPPP sign on site?** (see permit part 1.9) **Yes** **Required**
The sign must include the UPDES tracking number, the owner or general contractor name, phone number and email, and if the SWPPP is on-line, instructions on how to view it. The size requirement is to be readable from a publicly accessible point. Use BMP 2.1 SWPPP Sign
- 2.2 Will there be construction dewatering on the site?** (see permit part 2.7) **Yes** **No**
BMP(s): Dewatering of the construction area is needed and a separate dewatering permit has been obtained to treat and discharge water. *Construction Dewatering (if discharged offsite) must be covered by UPDES Permit UTG070000.*
 Water from the dewatering of the construction area will be infiltrated on site.
- 2.3 Will there be non-storm water discharges on the site?** (see permit part 1.3) **Yes** **No**
Allowable discharges include: Flushing of drinking water or irrigation water (not including wash or cleaning waters), water used for dust control, spring water or groundwater not exposed to construction activities, water from emergency fire-fighting activities, and water from foot drains not

exposed to construction activities. (see permit part 2.4.5 & 2.9). Use BMP 2.2.3 Mechanical Sweeping as required.

Please list all anticipated non-storm water discharges: Dust Control activities

What will you do to manage the non-storm water discharges? Water used for dust control must be limited to an amount needed to provide a protective crust on disturbed soils, and used during dry weather. Sweeping is to be done before the end of business day if discharge from these activities occurs.

- BMP(s):**
- All non-storm water discharges are listed as allowable per permit part 1.3 and discharged
 - All non-storm water discharges that are not allowed are properly contained (see questions 2.12)
 - All non-storm water discharges that are contaminated with sediment only (free of chemicals, oils, etc.) will be treated in a sediment basin or equivalent (see permit part 2.8.1).
 - Other: [Click here to enter text.](#)

- 2.4 Is it possible for the total area of disturbance to be phased, minimizing the total exposure of disturbed soil at one time?** (see permit part 2.3.1) Yes No
- If disturbance can be minimized please show the locations on the site map and summarize (here) where disturbances will be delayed for some of the disturbed area:* [Click here to enter text.](#)

- 2.5 What perimeter controls will be used to prevent sediment from leaving the site?** (permit part 2.1.2 & 2.3)

- BMP(s):**
- | | |
|---|---|
| <input checked="" type="checkbox"/> Silt Fence | <input type="checkbox"/> Berms |
| <input type="checkbox"/> Vegetative Buffer | <input type="checkbox"/> Cut-Back-Curb |
| <input type="checkbox"/> Staked straw Wattles (Fiber Rolls) | <input type="checkbox"/> Weighted Wattles |
| <input checked="" type="checkbox"/> Other: Track Out Pad | |

- 2.6 Are surface waters located within 50 feet of your project's earth disturbances?** Yes No
- Note:** A 50' natural vegetative buffer MUST be maintained by water bodies. If a buffer less than 50' is used, you must demonstrate that the additional controls offer the same protection as a 50' natural vegetative buffer, and select the reason for exemption below. (see permit part 2.3.5)

- BMP(s):**
- 30' Natural Vegetative Buffer
- If less than 30' Natural Vegetative Buffer select additional Controls:
- 2 Silt Fence Barrier
 - 2 Straw Wattle Barriers (Fiber Roll)
 - Other: [Click here to enter text.](#)

- 2.7 Are there critical or sensitive areas (such as preservation of the drip lines around trees, wetlands, buffer zones by water bodies, etc.) located on or adjacent to the site?** (see permit part 2.2) Yes No

- BMP(s):**
- Separate and isolate with environmental fencing
 - Other: [Click here to enter text.](#)

- 2.8 What track out control will be used to prevent dirt from being tracked on streets as vehicles leave the site?** (see permit part 2.4.1) Use BMP SCE Stabilized Construction Entrance

- BMP(s):**
- | | | |
|---|---|---------------------------------------|
| <input checked="" type="checkbox"/> Track Out Pad | <input type="checkbox"/> Cobble | <input type="checkbox"/> Gravel |
| <input type="checkbox"/> Rumble Strips | <input type="checkbox"/> Wash Down Pad | <input type="checkbox"/> Delivery Pad |
| <input type="checkbox"/> Restricted Site Access | <input type="checkbox"/> Selective Access During Dry Weather (Dry soil) | |

Other: Click here to enter text.

2.9 Do you have storm drain inlets on or down gradient of this site? (see permit part 2.1.3) **Yes** **No**

Protection must address the curb inlet opening (throat) as well as the grate.

Where is/are the nearest downstream inlet(s) and how will you protect them: Approximately 5 to 10 feet downstream from the south lot corner. Utilize BMP IP-GB, Inlet Protection - Gravel Bags.

BMP(s): Rock/Sand-filled Bags Drop Inlet Bags
 Filter Fabric Gravel or Sand filled Wattles
 Proprietary inlet devices
 Other: Click here to enter text.

2.10 Will curb ramps be used at the site? (see permit part 2.4.2) **Yes** **No**

If curb ramps are used it must be done with material [not dirt] that will not wash away in storm water.

BMP(s): Crushed Rock Wood/Steel Ramps
 Other: Click here to enter text.

2.11 Will there be stockpiles or spoil piles on the site? **Yes** **No**

Note: Select "Contained by other BMP" if another BMP on your site will contain runoff from the stockpiles. Materials that can be transported with precipitation must not be placed in the street. (see permit part 2.1.1) Utilize BMPs SM Stockpile Management, 2.3.5 Topsoil Preservation Policy, and PC Plastic Covering.

BMP(s): Surrounded by Silt Fence Surrounded by Staked Straw Wattles
 Covered with Tarp Temporary – Removed same day
 Contained by other BMP. Explain: Click here to enter text.
 Other: Click here to enter text.

2.12 Does the project include installation of concrete, masonry, stucco, and paint (water based)work in this project? (see permit part 2.4.5 & 2.9.1) **Yes** **No**

Utilize BMP 2.6.5 Concrete Washout
Wash water must be contained, the solids dried, and disposed of at a landfill.

BMP(s): Lined Depression Steel Dumpster
 Regional Washout (per development)
 Other: Click here to enter text.

2.13 How will solid waste be dealt with on the site? (see permit part 2.4.3)

Light trash in uncovered dumpsters can blow out and scatter with wind and rain may fall on uncovered leachable material in the dumpster and leak out the bottom causing pollutants to escape. Utilize BMPs 2.6.1 Trash Receptacle and 2.6.2 Heavy Trash Policy

BMP(s): Bag Lightweight Trash Leak Proof Dumpsters
 Receptacles with Lids Other: Click here to enter text.

2.14 Will there be a need to dispose of solvents, oil, fuel, etc. liquid waste? (see permit part 2.9) **Yes** **No**

BMP(s): Contained and Removed from the site Collected for Reuse
 Other: Click here to enter text.

2.15 How will sanitary waste be handled on the site? (see permit part 2.4.4) Use BMP 2.6.4 Portable Toilet

BMP(s): Portable Toilet(s) (must be staked down on dirt surface & 10' from curb)

Places that are disturbed and then left for over 14 days with no activity, must be temporarily or permanently stabilized.

- BMP(s):** Bark or other mulch Hydro-mulch Seeding
 Tackifier Staked netting with straw mulch
 Other: [Click here to enter text.](#)

2.23 Will the house be sold without any landscaping? Yes No

If so, how will you leave the site for the new home owner so sediment will be contained on site until the home owner completes landscaping? *(the permit can be terminated when the owner occupies the house even though the site is not stabilized). Silt Fence shall be left in place and maintained after vegetation installation whether before or after contractor construction completion. Use BMP SF Silt Fence.*

- BMP(s):** Mulching/Hydro-mulching Swales Silt Fence
 Wattles Cut-Back-Curb Seeding
 Vegetated Buffer Grade Front-Yard Lower than Sidewalk
 Other: [Click here to enter text.](#)

3. Sequence of Construction Activity

Type of Construction Activity	Approximate Date Range
Start/End of the Project	
Excavation activities	
Foundation/Footings	
Backfill	
Erection of Building	
Utility Lines installed	
Landscaping (if the house is sold or occupied by owner with landscaping, if not landscaping should not be included)	

4. Site Map

On a blank page (or include a page from the architectural drawings that show site layout and dimensions), please draw a map (and place this map in Appendix A) showing the layout of the site including locations of:

1. boundaries of project/property
2. boundaries of disturbance (including areas outside of property boundaries)

3. show slopes on site (if there are steep areas show steep areas)
4. location of structures/facilities
5. locations of :
 - a. stockpiles for soils and materials
 - b. construction supplies
 - c. portable toilets
 - d. garbage/trash containers
 - e. egress points/track out pads
 - f. concrete washout pits or containers
6. water bodies, wetlands, natural vegetative buffers
7. placement of all BMPs, perimeter, erosion control, sediment control, inlet protection, etc.
8. storm water inlets and storm water discharge points (where storm water drains off the site)
9. areas that will be temporarily or permanently stabilized on the site
10. areas where disturbances will be delayed to minimize total exposed surface at one time.

5. Potential Sources of Pollutants

Potential sources of sediment to storm water runoff:

- Clearing and grubbing operations
- Grading and site excavation operations
- Vehicle tracking
- Topsoil stripping and stockpiling
- Landscaping operations

Potential pollutants and sources, other than sediment, to storm water runoff:

- Combined Staging Area—small fueling activities, minor equipment maintenance, sanitary facilities, and hazardous waste storage.
- Materials Storage Area—general building materials, solvents, adhesives, paving materials, paints, aggregates, trash, and so on.
- Construction Activity—paving, curb/gutter installation, concrete pouring/mortar/stucco, and building construction
- Concrete Washout Area

For all potential construction site pollutants, see Table 2 below.

Table 2. Potential construction site pollutants. Circle all that applies to your site and in the last column identify pollution prevention measures to minimize their discharge.

Material/Chemical	Storm Water Pollutants	Common Location*	Pollution Prevention Methods
Pesticides (insecticides, fungicides, herbicides, rodenticide)	Chlorinated hydrocarbons, organophosphates, carbamates, arsenic	Herbicides used for noxious weed control	

Material/Chemical	Storm Water Pollutants	Common Location*	Pollution Prevention Methods
Fertilizer	Nitrogen, phosphorous	Newly seeded areas	
Plaster	Calcium sulphate, calcium carbonate, sulfuric acid	Building construction	3.0 Spill Control Plan
	Perchloroethylene, methylene chloride, trichloroethylene, petroleum distillates	No equipment cleaning allowed in project limits	
Asphalt	Oil, petroleum distillates	Streets and roofing	3.0 Spill Control Plan
Concrete	Limestone, sand, pH, chromium	Curb and gutter, building construction	2.6.5 Concrete Washout
Glue, adhesives	Polymers, epoxies	Building construction	2.7.1 Storage Policy
Paints	Metal oxides, Stoddard solvent, talc, calcium carbonate, arsenic	Building construction	3.0 Spill Control Plan
Curing compounds	Naphtha	Curb and gutter	3.0 Spill Control Plan
Wood preservatives	Stoddard solvent, petroleum distillates, arsenic, copper, chromium	Timber pads and building construction	
Hydraulic oil/fluids	Mineral oil	Leaks or broken hoses from equipment	3.0 Spill Control Plan 2.7.1 Storage Policy
Gasoline	Benzene, ethyl benzene, toluene, xylene, MTBE	Secondary containment/staging area	3.0 Spill Control Plan
Diesel Fuel	Petroleum distillate, oil & grease, naphthalene, xylenes	Secondary containment/staging area	3.0 Spill Control Plan
Kerosene	Coal oil, petroleum distillates	Secondary containment/staging area	
Antifreeze/coolant	Ethylene glycol, propylene glycol, heavy metals (copper, lead, zinc)	Leaks or broken hoses from equipment	3.0 Spill Control Plan 2.7.1 Storage Policy
Sanitary toilets	Bacteria, parasites, and viruses	Staging area	2.6.4 Portable Toilet

*(Area where material/chemical is used on-site)

6. Spill Prevention and Response Plan

Describe the spill prevention and control plan to include ways to reduce the chance of spills, stop the source of spills, contain and cleanup spills, dispose of materials contaminated by spills, and train personnel responsible for spill prevention and control. Additionally, fill in all **BLUE** fields below.

Spill Plan:

Utilize BMP 3.0 Spill Control

Any discharges in 24 hours equal to or in excess of the reportable quantities listed in 40 CFR 117, 40 CFR 110, and 40 CFR 302 will be reported to the National Response Center and the Division of Water Quality (DWQ) as soon as practical after knowledge of the spill is known to the permittee. The permittee shall submit within 14 calendar days of knowledge of the release a written description of: the release (including the type and estimate of the amount of material released), the date that such release occurred, the circumstances leading to the release, and measures taken and/or planned to be taken to the Division of Water Quality (DWQ), 288 North 1460 West, P.O. Box 144870, Salt Lake City, Utah 84114-4870. The Storm Water Pollution Prevention Plan must be modified within 14 calendar days of knowledge of the release to provide a description of the release, the circumstances leading to the release, and the date of the release. In addition, the plan must be reviewed to identify measures to prevent the reoccurrence of such releases and to respond to such releases, and the plan must be modified where appropriate.

Agency	Phone Number
National Response Center	(800) 424-8802
Division of Water Quality (DWQ) 24-Hr Reporting	(801) 538-6146; (801) 536-4123
Utah Department of Health Emergency Response	(801) 580-6681
Huntsville Fire Department	801-745-9277

Minimum spill quantities requiring reporting:

Material	Media Released To	Reportable Quantity
Engine oil, fuel, hydraulic & brake fluid	Land	25 gallons
Paints, solvents, thinners	Land	100 lbs (13 gallons)
Engine oil, fuel, hydraulic & brake fluid	Water	Visible Sheen
Refrigerant	Air	1 lb
Antifreeze, battery acid, gasoline, engine degreasers	Air, Land, Water	100 lbs (13 gallons)

Emphasis to:

- 1st Priority: Protect all people (including onsite staff)
- 2nd Priority: Protect equipment and property
- 3rd Priority: Protect the environment

1. Make sure the spill area is safe to enter and that it does not pose an immediate threat to health or safety of any person.
2. Check for hazards (flammable material, noxious fumes, cause of spill) – if flammable liquid, turn off engines and nearby electrical equipment. If serious hazards are present leave area and call 911. LARGE SPILLS ARE LIKELY TO PRESENT A HAZARD.
3. Stop the spill source and contain flowing spills immediately with spill kits, dirt or other material that will achieve containment.

4. Call co-workers and supervisor for assistance and to make them aware of the spill and potential dangers
5. If spilled material has entered a storm sewer, regardless of containment; contact the City Storm Water Division.
6. Cleanup all spills (flowing or non-flowing) immediately following containment. Clean up spilled material according to manufacturer specifications, for liquid spills use absorbent materials AND DO NOT FLUSH AREA WITH WATER.
7. Properly dispose of cleaning materials and used absorbent material according to manufacturer specifications.
8. Report the reportable quantity to the Weber County Storm Water Division.

Emergency Numbers

Utah Hazmat Response Officer 24 hrs	(801)-538-3745
Weber County Sherriff's Office	801-395-8221
Weber County Engineering Division	801-399-8374

7. SWPPP, Inspections and Corrective Action Reports

Inspection Schedule and Procedures: The permit requires inspections once a week (see permit Part 3). You must list and provide details of your BMPs in Appendix G. Inspection reports require reporting on BMPs and how effective they are (download inspection reports from the DWQ construction storm water website under the Common Plan Permit). You may be required to maintain, modify, remove, or apply/install more or different BMPs to control pollutants on the site. Please number your BMPs in Appendix G and refer to those numbers on your inspection reports and corrective action reports when you inspect or report on them.

Describe the general procedures for correcting problems when they are identified. Include responsible staff and time frames for making corrections:

SWPPP maintenance personnel shall make corrections to deficiencies listed in inspection reports within 48 hours, unless individual BMP requirements mandate a more timely response.

Inspections and Corrective Actions: All inspections and corrective actions must be logged using the "Inspection/Correction Action Log" attached in Appendix E. The log should be filled out completely for each BMP.

8. Training of Sub-Contractors

All sub-contractors, installers of utility connections, and others that perform activities that are affected by permit requirements will be informed about permit requirements that pertain to their scope of work.

Sub-Contractors that have been informed:

Contractor	Date	Topic(s) Covered	Initials of Trainer
Excavator			
Gas utilities			
Plumbing connection			
Electrical connection			
Concrete foundation walls			
Concrete flat work			
Landscaper			
Other:			
Other:			
Other:			
Other:			

9. Changes to the SWPPP

All changes to this SWPPP must be redlined, dated, and initialed in the SWPPP document and on the site map.

10. Record Keeping

The following items should be kept at the project site available for inspectors to review:

1. A copy of the Common Plan Permit (Appendix B)
2. The signed and certified NOI form (Appendix C)
3. Inspection reports (Appendix E)

11. Delegation of Authority (if any)

Duly Authorized Representatives or Positions:

Company/Organization:

Name:

Position:

Address:

City:

State: State

Zip:

Telephone:

Fax/Email:

Owner/General Contractor Signature: _____ Date: _____

Additional Duly Authorized Representatives or Positions:

Company/Organization:

Name:

Position:

Address:

City: _____ State: _____ Zip: _____
 Telephone: _____ Fax/Email: _____

Owner/General Contractor Signature: _____ Date: _____

12. Discharge Information

Does your project/site discharge storm water into a Municipal Separate Storm Sewer System (MS4)?
 Yes No

Municipal Storm Drain System receiving the discharge from the construction project: Weber County

Receiving Waters (look up <http://mapserv.utah.gov/surfacewaterquality/> to identify your receiving water body). If you discharge to a MS4 you may need to contact them to determine the receiving water that their system outfalls to.

Enter the name(s) of the first surface water(s) that receives storm water directly from your site and/or from the MS4 listed above. **Note:** *multiple rows provided in the case that your site has more than one point of discharge in which each flows to different surface waters.*

1. **Pineview reservoir about than about 2/3 of a mile to the north.**
2. [Click here to enter name of receiving waters.](#)
3. [Click here to enter name of receiving waters.](#)
4. [Click here to enter name of receiving waters.](#)

Impaired Waters (refer to <http://mapserv.utah.gov/surfacewaterquality/> in the left hand column to determine status of receiving water body).

Select any impaired surface water(s) that your site will discharge to, either directly or through the MS4 selected above.

Surface Water	Is this surface water impaired?	Pollutant(s) causing the impairment	Has a TMDL been completed?	Pollutant(s) for which there is a TMDL
Pineview Reservoir	<input checked="" type="checkbox"/> Yes <input type="checkbox"/> No	Use Class 3A (Cold Water Fishery/Aquatic Life): Dissolved Oxygen, pH, Phosphorus, Temperature	<input checked="" type="checkbox"/> Yes <input type="checkbox"/> No	Temperature, Dissolved Oxygen, pH, Phosphorus
Click here to enter text.	<input type="checkbox"/> Yes <input type="checkbox"/> No	Click here to enter text.	<input type="checkbox"/> Yes <input type="checkbox"/> No	Click here to enter text.

13. Certification and Notification

I, Name of Authorized Construction Operator Representative, certify under penalty of law that this document and all attachments were prepared under my direction or supervision in accordance with a system designed to assure that qualified personnel properly gathered and evaluated the information submitted. Based on my inquiry of the person or persons who manage the system, or those persons directly responsible for gathering the information, the information submitted is, to the best of my knowledge and belief true, accurate, and complete. I am aware that there are significant penalties for submitting false information, including the possibility of fine and imprisonment for knowing violations.

X

Construction Operator:

This SWPPP should be signed and certified by the construction operator(s).

SWPPP Appendices

Ensure the following documentation is attached to the SWPPP:

Appendix A: SWPPP Site Maps

Appendix B: Common Plan Permit

Appendix C: Notice of Intent (NOI), and a copy of the NOT form unless you plan to terminate the permit on-line

Appendix D: Daily Site Check Log

Appendix E: Inspection Reports and Corrective Actions

Appendix F: Additional Information (i.e. permits such as local permits, dewatering, stream alteration, wetland, and out of date SWPPP documents, delegation of authority forms, etc.)

Appendix G: BMP Specifications and Details (label BMPs to match the sections identified in this document.)

APPENDIX A: SWPPP Site Maps

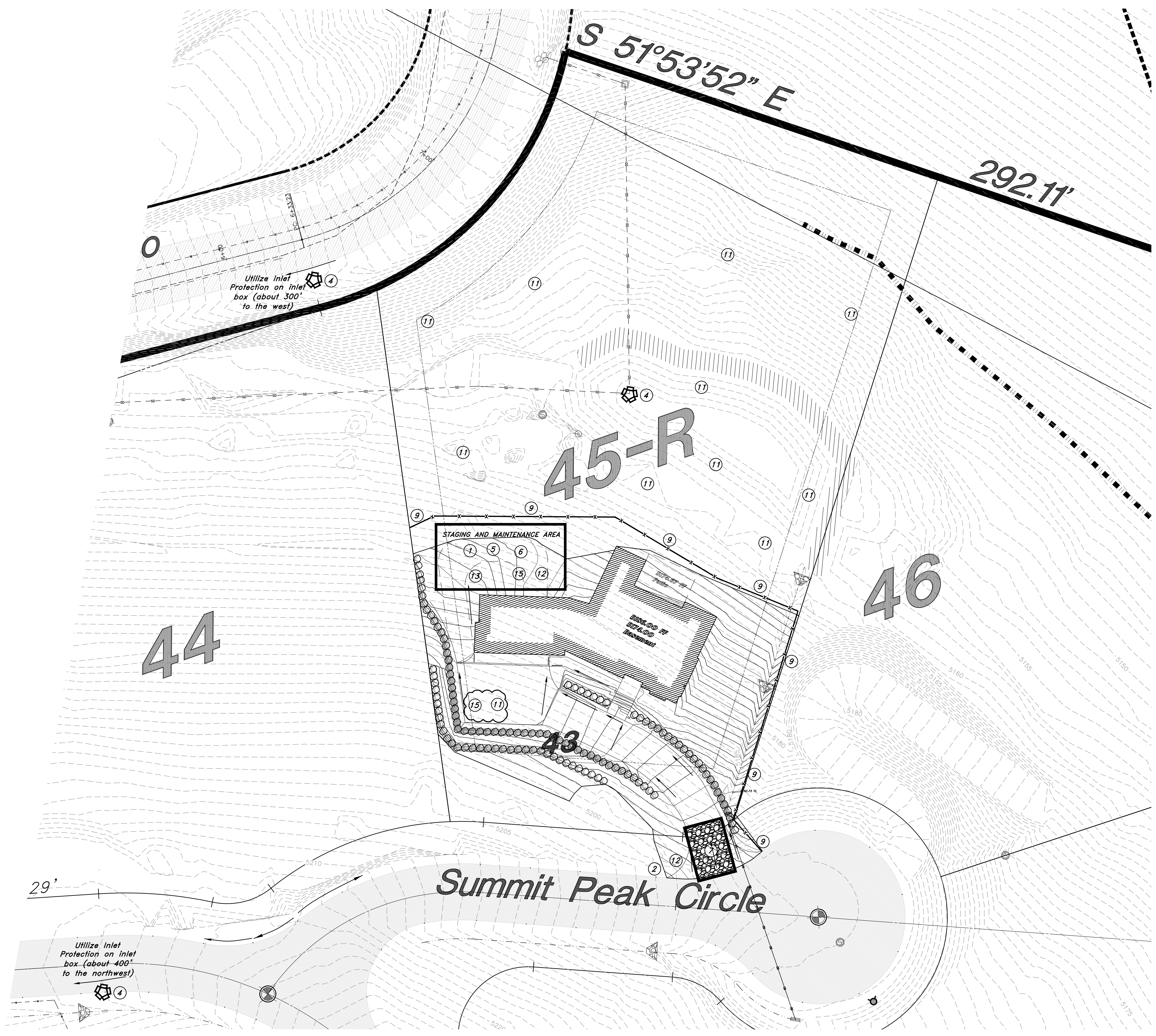
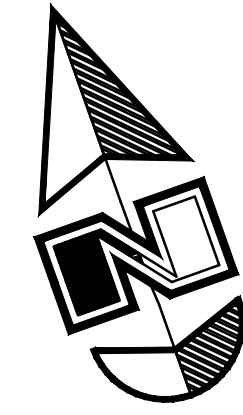
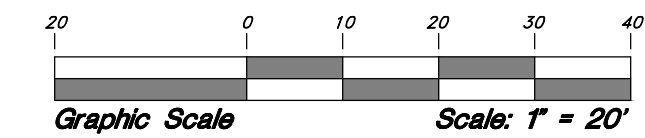

NOTES:
This sheet constitutes the Sediment and Erosion Control Plan (SECP). This sheet may be included in the improvement drawing plan set for this project, but only as a courtesy. This sheet is most importantly included in the Common Plan of Development Storm Water Pollution Prevention Plan (CPoD SWPPP) for this project.

Neither the SECP nor the combination of the SECP along with the BMP details constitutes a Common Plan of Development Storm Water Pollution Prevention Plan (CPoD SWPPP). Those are only appendices to the CPoD SWPPP. The CPoD SWPPP for this project was developed using the State Template. A copy of the CPoD SWPPP needs to be available while the NOI is active.

SELECTED BMPs

1. Utilize BMP 2.6.5 Concrete Washout
2. Const. BMP 2.1 SWPP Sign
3. Utilize BMP 2.4.1 Hose
4. Const. BMP IP-GB Inlet Protection (Gravel Bags)
5. Utilize BMP 2.7.1 Storage Policy
6. Const. BMP 2.6.4 Portable Toilet
7. Const. BMP SCE Stabilized Construction Entrance
8. Utilize BMP 3.0 Spill Control Plan
9. Const. BMP SF Silt Fence
10. Utilize BMP 2.2.3 Mechanical Sweeping
11. Utilize BMP 2.3.5 Tossall Preservation Policy
12. Utilize BMP 2.6.1 Trash Receptacle
13. Utilize BMP 2.6.2 Heavy Trash Policy
14. Utilize BMP SR Surface Roughening
15. Const. BMP PC Plastic Covering

OWNER
Owner: James & Vicki Berger
Client: Phillip Clawson
Hi-C Construction and Design
Office@hiconstructiondesign.com
801-603-2727

ENGINEER
Mark Babbitt, PE/PLS
Great Basin Engineering
5746 South 1475 East
South Ogden, UT 84403
801-394-1545
MarkB@GreatBasinENG.com

REV	DATE	DESCRIPTION

GREAT BASIN ENGINEERING
5746 SOUTH 1475 EAST, OGDEN, UTAH 84403
801-394-1545 FAX: (801) 392-7444
WWW.GREATBASINENGINEERING.COM

Sediment & Erosion Control Plan
Hi-C Construction Lot# 45R
Summit at Ski Lake #12
6842 East Summit Peak Circle
Huntsville, Utah 84317
A part of Northeast Quarter Section 24, T6N, R1E, S16&M, U.S. Survey

May 2022

SHEET NO. **SECP**

APPENDIX B: Common Plan Permit

Find the permit on <https://deq.utah.gov/water-quality/general-construction-storm-water-updes-permits>

APPENDIX C: Notice of Intent and Termination.

Find the Notice of Termination Form at <https://deq.utah.gov/water-quality/general-construction-storm-water-updes-permits>

However, termination of the project can be done on-line at <https://deq.utah.gov/water-quality/updes-ereporting#construction>

(You must log in using the same username that you applied for your NOI with. If you completed a downloadable NOI you must complete and return a downloadable NOT.)

APPENDIX D: Daily Self-Inspection Log (permit part 3.2.2).

APPENDIX E: Inspection Reports

APPENDIX F: Additional Information

For permits such as local permits, dewatering, stream alteration, wetland, and out of date SWPPP documents, delegation of authority forms, etc.

Delegation of Authority

I, _____ (name), hereby designate the person or specifically described position below to be a duly authorized representative for the purpose of overseeing compliance with environmental requirements, including the Common Plan Permit, at the _____ construction site. The designee is authorized to sign any reports, stormwater pollution prevention plans and all other documents required by the permit.

_____ (name of person or position)

_____ (company)

_____ (address)

_____ (city, state, zip)

_____ (phone)

By signing this authorization, I confirm that I meet the requirements to make such a designation as set forth in _____ (Reference State Permit), and that the designee above meets the definition of a “duly authorized representative” as set forth in _____ (Reference State Permit).

I certify under penalty of law that this document and all attachments were prepared under my direction or supervision in accordance with a system designed to assure that qualified personnel properly gathered and evaluated the information submitted. Based on my inquiry of the person or persons who manage the system, or those persons directly responsible for gathering the information, the information submitted is, to the best of my knowledge and belief, true, accurate, and complete. I am aware that there are significant penalties for submitting false information, including the possibility of fine and imprisonment for knowing violations.

Name:

Company:

Title:

Signature:

Date:

APPENDIX G: BMP Specifications and Details

Label BMPs to match the sections identified in this document.

2.6.5 Concrete Washout

Operation or Site Condition: Concrete supplier and concrete materials workers will need a place to wash equipment and dispose of excess material.

Instruction: Concrete Supplier and Brick Mason are required to wash equipment and excess material in this BMP. Do not wash your chassis on the street. Practice BMP SCE Stabilized Construction Entrance whenever exiting the site. This BMP provides a adequate location to clean equipment including washing your chassis and will prevent mud from sticking to your tires.

Schedule: Prior to concrete pours

Maintenance: Replace when 50% full

Maintenance Personnel: Project Manager

Applicable Trades: Footing/Foundation, Flat Workers, Brick Masons, Painters and Interior Finishers

Detail:

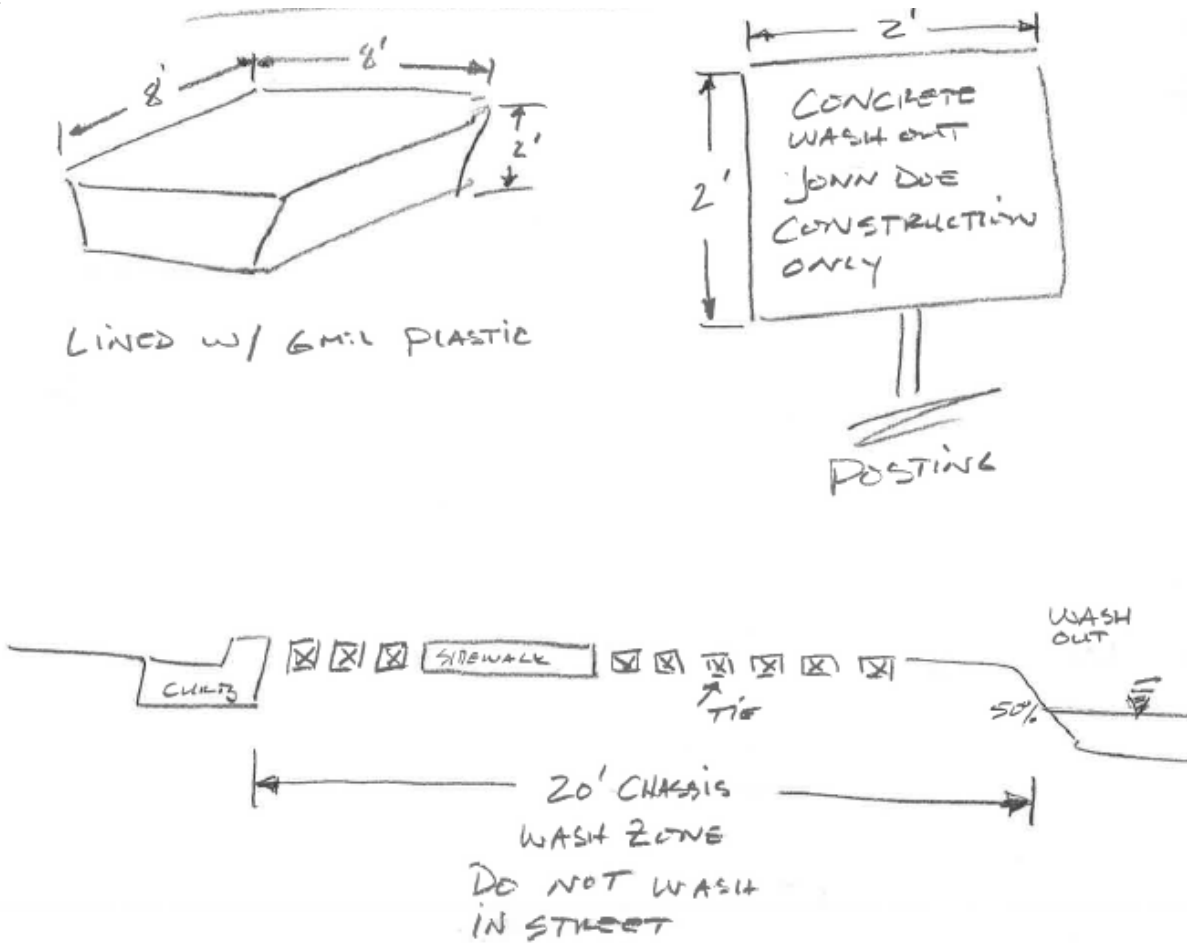

2.1 SWPPP Sign

Operations or Site Condition: NA

Instruction: See site plan for location

Installation Schedule: Prior to any land disturbance

Maintenance Requirements: Repair when damaged

Maintenance Personnel: Project Manager

Applicable Trades: NA

Detail:

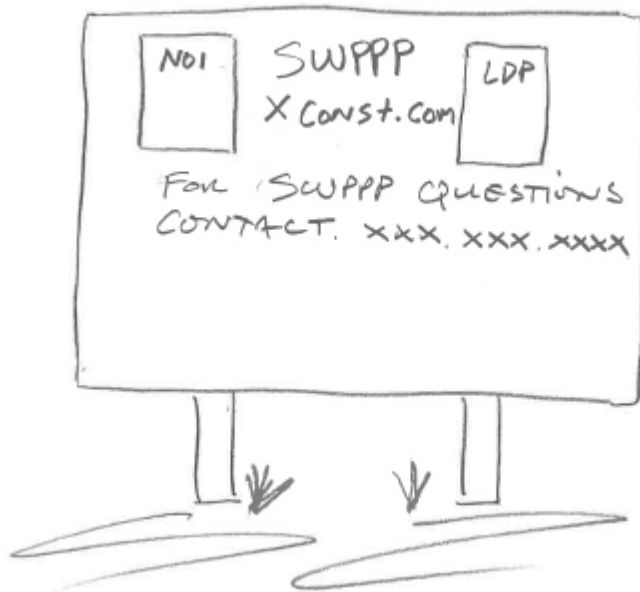

2.4.1 Hose

Operation or Site Condition: Excavation, grading and even other normal construction activity will kick up dust on hot windy days.

Instruction: Garden hose provided for construction operations kicking up dust or other activities involving light weight powdery materials.

Installation Schedule: Provide hose connected to a culinary water jumper from City Water Department prior to land disturbance.

Maintenance: Generally, apply during excavation, grading and mortar mixing operations. Also prior to end of work day ground is powdery.

Maintenance Personnel: Project Manager will watch for general dry dusty conditions. However, each trade will be expected to use this BMP for operations they are responsible for. Primarily for excavation, grading and Brick Mason operations however any trade kicking up dust is expected to implement this BMP.

Applicable Trades: Primarily Excavator, Grader and Brick Masons but also any trade whose operation is kicking up dust.

Detail: NA

BMP: Inlet Protection - Gravel Bags

IP-GB

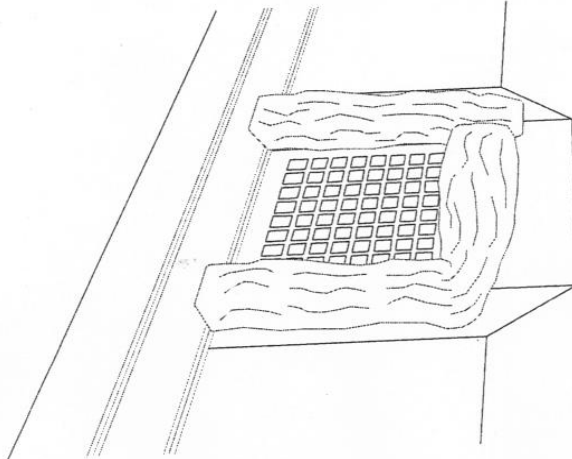

OBJECTIVES

- Housekeeping Practices
- Contain Waste
- Minimize Disturbed Areas
- Stabilize Disturbed Areas
- Protect Slopes/Channels
- Control Site Perimeter
- Control Internal Erosion

TARGETED POLLUTANTS

H M L

- Sediment
- Nutrients
- Heavy Metals
- Toxic Materials
- Oil & Grease
- Floatable Materials
- Bacteria & Viruses
- Other Waste

IMPLEMENTATION REQUIREMENTS

H M L

- Capital Costs
- O&M Costs
- Maintenance
- Training
- Staffing
- Administrative

H = High M = Medium L = Low

DESCRIPTION:

Sediment barrier erected around storm drain inlet.

APPLICATION:

Construct at storm drainage inlets located down-gradient of areas to be disturbed by construction

INSTALLATION / APPLICATION CRITERIA:

- Provide up-gradient sediment controls, such as silt fence during construction of inlet
- When construction of curb and gutter and roadway is complete, install gravel filled bags around perimeter of inlet
- Fill to recommended levels to reduce splitting of bags

LIMITATIONS:

- Recommended maximum contributing drainage area of one acre
- Requires shallow sloped adjacent to inlet.

MAINTENANCE:

- Inspect inlet protection following storm event and at a minimum of once every 14 days.
- Remove accumulated sediment when it reaches half the height of the bag.
- Look for bypassing or undercutting and repair or realign as needed.
- Replace and clean up spilled gravel when bags split.

2.7.1 Storage Policy

Operation or Site Condition: About 30 gallons of various liquids will be used for this project but will not be necessary until the foundation is complete. About 1000 lbs of various power will be necessary for this project and again will not be necessary until foundation and framing is complete.

Instruction: Store any liquids or powder supplies in the foundation for inside the building at all times.

Schedule: NA

Maintenance: NA

Maintenance Personnel: NA

Applicable Trades: Primarily, carpentry finishers, painters, brick masons or any tradesmen needing to store liquid or erodible construction materials not covered specific BMPs.

Detail: NA

2.6.4 Portable Toilet

Operation or Site Condition: A portable toilet is necessary for the duration of this project

Instruction: Portable toilet is to be coordinated by Contractor or Sub. The Portable toilet is located in the staging and maintenance area on the west side of the site. The BMP SF Silt Fence will trap and contain sewer in the event of tipping. Appropriate Sub is required to use BMP SCE Stabilized Construction Entrance when exiting the site.

Schedule: Prior to land disturbance

Maintenance: NA other than keeping it on the parking surface for pick up and drop off.

Maintenance Personnel: Project Manager, Selected Portable Toilet Company

Applicable Trades: Project Manager. Selected Portable Toilet Company

Detail: NA

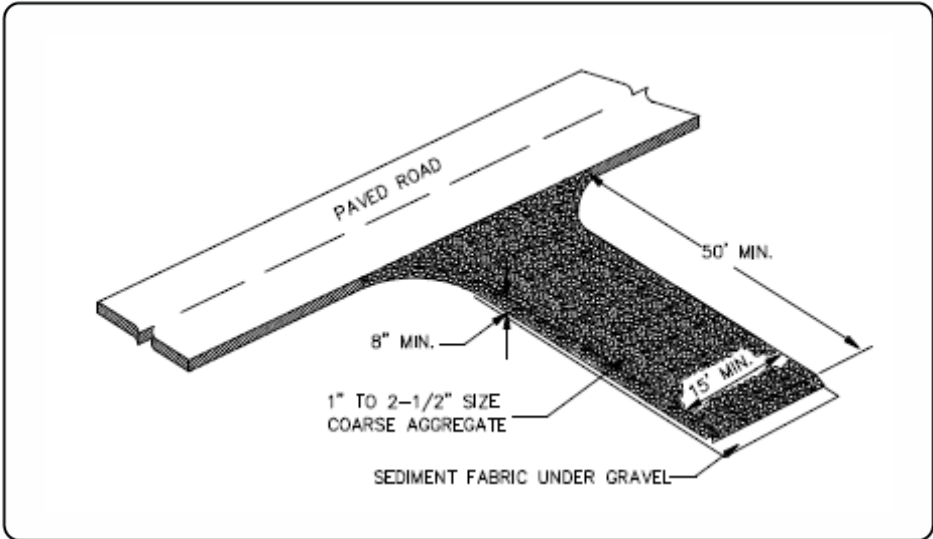

DESCRIPTION:

A stabilized pad of crushed stone located where construction traffic enters or leaves the site from or to paved surface.

APPLICATIONS:

- ▶ At any point of ingress or egress at a construction site where adjacent traveled way is paved. Generally applies to sites over 2 acres unless special conditions exist.

INSTALLATION/APPLICATION CRITERIA:

- ▶ Clear and grub area and grade to provide maximum slope of 2%.
- ▶ Compact subgrade and place filter fabric if desired (recommended for entrances to remain for more than 3 months).
- ▶ Place coarse aggregate, 1 to 2-1/2 inches in size, to a minimum depth of 8 inches.

LIMITATIONS:

- ▶ Requires periodic top dressing with additional stones.
- ▶ Should be used in conjunction with street sweeping on adjacent public right-of-way.

MAINTENANCE:

- ▶ Inspect daily for loss of gravel or sediment buildup.
- ▶ Inspect adjacent roadway for sediment deposit and clean by sweeping or shoveling.
- ▶ Repair entrance and replace gravel as required to maintain control in good working condition.
- ▶ Expand stabilized area as required to accommodate traffic and prevent erosion at driveways.

OBJECTIVES

- Housekeeping Practices
- Contain Waste
- Minimize Disturbed Areas
- Stabilize Disturbed Areas
- Protect Slopes/Channels
- Control Site Perimeter
- Control Internal Erosion



WEBER COUNTY

ENGINEERING DEPARTMENT

2380 Washington Blvd., Suite 240
Ogden, UT 84401
(801) 399-8374

TARGETED POLLUTANTS

- Sediment
- Nutrients
- Toxic Materials
- Oil & Grease
- Floatable Materials
- Other Waste

- High Impact
- Medium Impact
- Low or Unknown Impact

IMPLEMENTATION REQUIREMENTS

- Capital Costs
- O&M Costs
- Maintenance
- Training

- High
- Medium
- Low

3.0 Spill Control Plan

Operations or Site Condition: Spills can happen at any time. The project may extend into winter which would necessitate a plan that will work in freezing temperatures and snowy conditions.

Instruction:

1. Containment: Two 5 gal buckets with lids filled with sand are located at the low side of the project in the park strip, see site plan. Keep lid closed so the sand will stay dry. Wet sand will likely freeze solid. These are intended for containing flowing spills and absorbing spilled liquids, however, when site conditions allow dirt may also be used. You will need your own shovel.
2. Cleanup and Disposal: It will only take minutes to dam then absorb any liquid. Clean up immediately following the spill event. Dispose waste in BMP 2.6.5 unless the SDS directs otherwise.

Installation Schedule: Prior to any land disturbance

Maintenance Requirements: Replace as used

Maintenance Personnel: Project Manager

Applicable Trades: All

Detail: NA

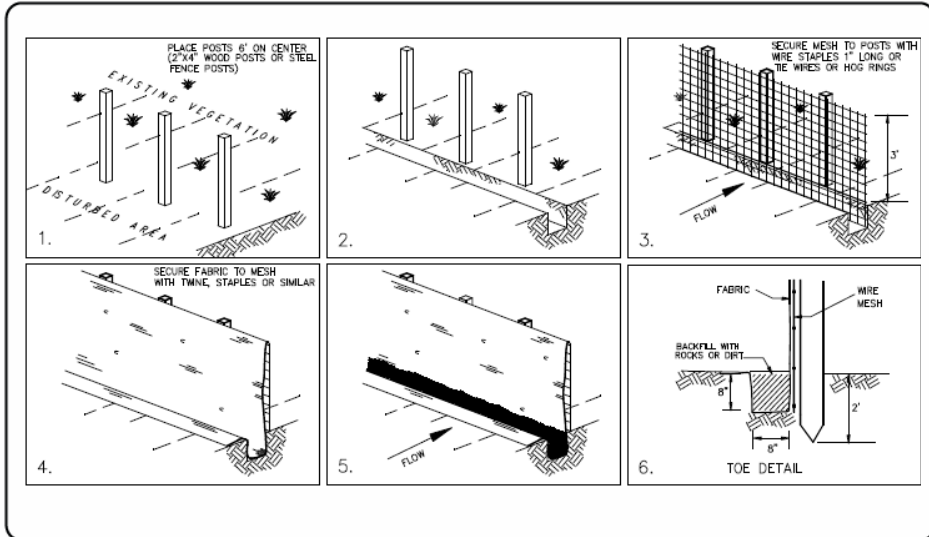

- ### OBJECTIVES
- Housekeeping Practices
 - Contain Waste
 - Minimize Disturbed Areas
 - Stabilize Disturbed Areas
 - Protect Slopes/Channels
 - Control Site Perimeter
 - Control Internal Erosion



WEBER COUNTY

ENGINEERING DEPARTMENT
 2380 Washington Blvd., Suite 240
 Ogden, UT 84401
 (801) 399-8374

DESCRIPTION:

- ▶ A temporary sediment barrier consisting of entrenched filter fabric stretched across and secured to supporting posts.

APPLICATION:

- ▶ Perimeter control: place barrier at downgradient limits of disturbance
- ▶ Sediment barrier: place barrier at toe of slope or soil stockpile
- ▶ Protection of existing waterways: place barrier at top of stream bank
- ▶ Inlet protection: place fence surrounding catchbasins

INSTALLATION/APPLICATION CRITERIA:

- ▶ Place posts 6 feet apart on center along contour (or use preassembled unit) and drive 2 feet minimum into ground. Excavate an anchor trench immediately upgradient of posts.
- ▶ Secure wire mesh (14 gage min. With 6 inch openings) to upslope side of posts. Attach with heavy duty 1 inch long wire staples, tie wires or hog rings.
- ▶ Cut fabric to required width, unroll along length of barrier and drape over barrier. Secure fabric to mesh with twine, staples, or similar, with trailing edge extending into anchor trench.
- ▶ Backfill trench over filter fabric to anchor.

LIMITATIONS:

- ▶ Recommended maximum drainage area of 0.5 acre per 100 feet of fence
- ▶ Recommended maximum upgradient slope length of 150 feet
- ▶ Recommended maximum uphill grade of 2:1 (50%)
- ▶ Recommended maximum flow rate of 0.5 cfs
- ▶ Ponding should not be allowed behind fence

MAINTENANCE:

- ▶ Inspect immediately after any rainfall and at least daily during prolonged rainfall.
- ▶ Look for runoff bypassing ends of barriers or undercutting barriers.
- ▶ Repair or replace damaged areas of the barrier and remove accumulated sediment.
- ▶ Reanchor fence as necessary to prevent shortcutting.
- ▶ Remove accumulated sediment when it reaches 1/2 the height of the fence.

- ### TARGETED POLLUTANTS
- Sediment
 - Nutrients
 - Toxic Materials
 - Oil & Grease
 - Floatable Materials
 - Other Waste
-
- High Impact
 - Medium Impact
 - Low or Unknown Impact

- ### IMPLEMENTATION REQUIREMENTS
- Capital Costs
 - O&M Costs
 - Maintenance
 - Training
-
- High
 - Medium
 - Low

2.3.3 Mechanical Sweeping

Operation and Site Condition: The small amounts of mud trapped in the tread will spread dirt on the streets overtime and some dirt can migrate or be spread by various operations which is expected and will be managed by the project manager, however, any trade not following BMPs that result in dirt on the roadways will be held accountable for any damages.

Instruction: Sweeping will be done by General Contractor or a contracted Sub

Installation Schedule: Schedule upon need

Maintenance Requirements: Dirt and mud of levels beyond manual sweeping capabilities.

Applicable Trades:

Maintenance Personnel: Project Manager to assign maintenance personnel. FYI any trade found to track mud or dirt unnecessarily will be billed for the cost.

Detail: NA

2.3.5 Topsoil Preservation Policy

Operation or Site Condition: Topsoil will be removed by the excavation and general grading operations also most of the sites surface will be disturbed by all trades involved in this home. It is necessary to remove and stockpile the topsoil in the footing and general home grading envelope so it can be preserved and reused.

Instruction:

1. Contractor or Sub shall remove topsoil under the footing, spoil zone and general home grading envelope. Stockpile near the west corner of the lot for the final grading construction phase. Note, this is not intended for the foundation backfill or the non topsoil spoil that must be hauled off.
2. Contractor or Sub, spread topsoil during last phase.
3. Utilize BMP 2.4.1 hose.

Installation Schedule: NA

Maintenance Requirements: NA

Applicable Trades: Excavator X and Grader X

Maintenance Personnel: NA

Detail: NA

2.6.1 Trash Receptacle

Operation or Site Conditions: All trades can generate light weight trash from the lunch box alone however, most will generate light weight trash as part of their operation. Light weight trash is the primary concern because it can blow off the site.

Instruction: Provide (2) 60 gal trash receptacles with lids chained to post near site entrance. All trades are required to use these or put your trash in your own vehicle. Do not fill receptacles with heavy weight trash see BMP 2.6.2 for Heavy Trash Policy.

Schedule: Prior to land disturbance

Maintenance: Ensure lids are always closed. Dump when trash is spilling over.

Maintenance Personnel: Project Manager. All trades are expected to close lids.

Applicable Trades: All trades generating light weight trash of any kind

Detail: NA

2.6.2 Heavy Trash Policy

Operation or Site Condition: This site will likely generate 30 yards of heavy trash

Instruction: To maintain room or all tradesmen pile all heavy trash in designated location shown on site map. Do not place light weight trash with the heavy weight trash. See BMP 2.6.1 for light weight trash control

Schedule: NA

Maintenance: Remove when spilling beyond trash envelop shown on site plan

Maintenance Personnel: Project Manager. All trades generating heavy trash.

Applicable Trades: All trades generating heavy trash or waste.

Detail: NA

BMP: Surface Roughening

SR

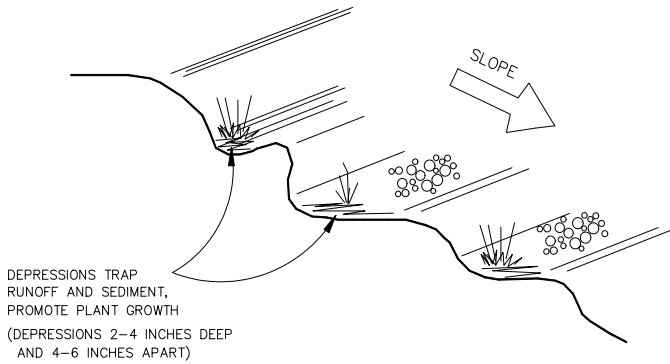

OBJECTIVES

- Housekeeping Practices
- Contain Waste
- Minimize Disturbed Areas
- Stabilize Disturbed Areas
- Protect Slopes/Channels
- Control Site Perimeter
- Control Internal Erosion

DESCRIPTION:

Rough preparation of working areas leaving depressions and uneven surface. Depressions should be done parallel to contours.

APPLICATION:

Surface roughening is appropriate for all construction that will not be receiving impervious cover within 14 days and that will be exposed less than 60 days (seed areas to be open in excess of 60 days).

INSTALLATION/APPLICATION CRITERIA:

- ▶ Surface should be left in rough condition during initial earthwork activity.
- ▶ Surfaces that have become smoothed or compacted due to equipment traffic should be roughened by use of disks, spring harrows, teeth on front end loader, or similar, operating along the contours of the slope. Tracking (by crawler tractor driving up and down slope) may also be used to provide depressions parallel to contours.
- ▶ Avoid compaction of soils during roughening as this inhibits plant growth and promotes storm water runoff. Limit tracked machinery to sandy soil.
- ▶ Seed or mulch areas to be exposed in excess of 60 days.
- ▶ Employ dust controls. (See Dust Control Detail Sheet).

LIMITATIONS:

- ▶ Will not withstand heavy rainfall.
- ▶ Slopes steeper than 2:1 (50%) should be benched. (See Benching Detail Sheet).

MAINTENANCE:

- ▶ Inspect following any storm event and at a minimum of weekly.
- ▶ If erosion in the form of rills (small waterways formed by runoff) is evident, perform machine roughening of area.
- ▶ For vegetated slopes reseed areas that are bare or have been reworked.

TARGETED POLLUTANTS

- Sediment
- Nutrients
- Toxic Materials
- Oil & Grease
- Floatable Materials
- Other Waste

- High Impact
- Medium Impact
- Low or Unknown Impact

IMPLEMENTATION REQUIREMENTS

- Capital Costs
- O&M Costs
- Maintenance
- Training

- High Medium Low

BMP PC

PLASTIC COVERING

DESCRIPTION

Plastic covering is used to cover exposed areas, which need immediate protection from erosion.

PURPOSE

The purpose of this BMP includes, but is not limited to:

- Providing immediate temporary erosion protection to slopes, piles and disturbed areas that cannot be covered by mulching.
- Protecting exposed surfaces from water and/or wind erosion.
- Used in winter months as a temporary erosive control device when grass seed will not germinate.

APPLICATIONS

This BMP may be used in disturbed areas, which require immediate erosion protection, areas seeded during winter and spring to aid in germination and for protection from heavy rain. Plastic covering may be used on steep slopes, construction sites and on stockpiles and/or excess materials. It may be used in combination with other BMPs.

LIMITATIONS

This BMP should not be used:

- For long term erosion control.
- Without controlling surface water runoff from the plastic covered area.

CONSTRUCTION GUIDELINES

- Plastic must be secured by staking or using weight (i.e. sandbag or tires) to prevent movement. Rebar must not be used as a staking mechanism.
- Plastic covering must be "keyed" in at the top of the slope.
- Additional BMPs, such as a berm and/or sediment control, must be used to control surface water runoff from plastic.

BMP MAINTENANCE

- During construction, inspect BMPs daily during the workweek.
-

Below are links to various Construction Storm Water BMP Manuals for reference.

Salt Lake County

http://slco.org/uploadedFiles/depot/publicWorks/engineering/final_bmp_constructi.pdf

BEST MANAGEMENT PRACTICES FOR CONSTRUCTION ACTIVITIES

Davis County

http://www.daviscountyutah.gov/docs/librariesprovider20/default-document-library/stormwater-best-management-practices.pdf?sfvrsn=c9cd4053_2

A Guide to Stormwater Best Management Practices

Nevada DOT

<https://www.nevadadot.com/home/showdocument?id=9417>

Stormwater Quality Manuals: Construction Site Best Management Practices (BMPs) Manual

Caltrans

<http://www.dot.ca.gov/hq/construc/stormwater/CSBMP-May-2017-Final.pdf>

Construction Site Best Management Practices (BMP) Manual

Oregon

<http://www.oregon.gov/deq/FilterPermitsDocs/BMPManual.pdf>

Construction Stormwater Best Management Practices Manual

Los Angeles

<http://dpw.lacounty.gov/cons/specs/BMPManual.pdf>

Construction Site Best Management Practices (BMPs) Manual

Maricopa County (Arizona)

<https://www.maricopa.gov/DocumentCenter/View/2368/2015-03-Drainage-Design-Manual-for-Maricopa-County-Volume-III-Erosion-pdf>

Drainage Design Manual for Maricopa County (Erosion Control)

Minnesota

<https://www.pca.state.mn.us/sites/default/files/wq-strm2-09.pdf>

Stormwater Compliance Assistance Toolkit for Small Construction Operators