

SCALE: 1"=60' (24x36 PLAN SET)

### TAYLOR LANDING PHASE 1A, 1st AMENDMENT A CLUSTER SUBDIVISION

PART OF THE NORTHWEST QUARTER OF SECTION 28,  
TOWNSHIP 6 NORTH, RANGE 2 WEST,  
SALT LAKE BASELINE AND MERIDIAN  
WEBER COUNTY, UTAH

#### FINAL PLAT FEBRUARY 2022

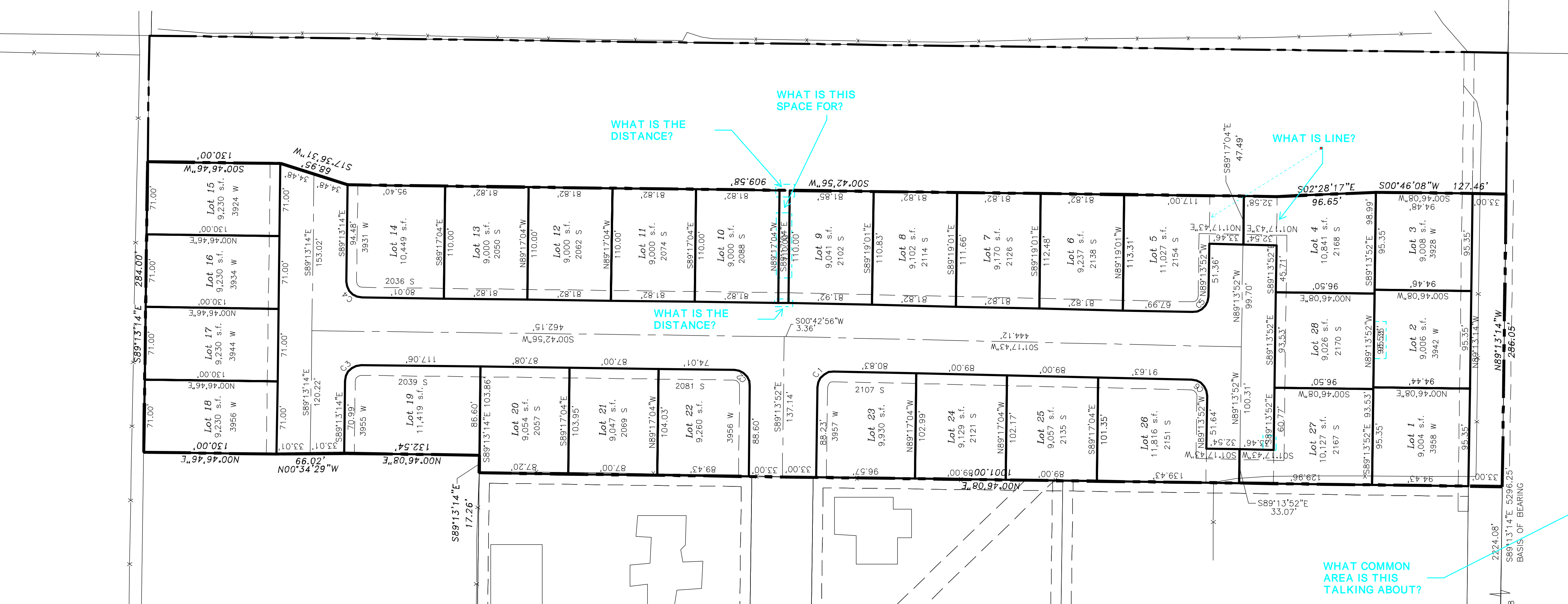

A signature block for County Surveyor conforming to state code and county ordinance.  
Weber County Surveyor:  
I hereby certify that the Weber County Surveyor's Office has reviewed this plat and all conditions for approval by this office have been satisfied. The approval of this plat by the Weber County Surveyor does not relieve the Licensed Land Surveyor who executed this plat from the responsibilities and/or liabilities associated therewith.  
Signed this \_\_\_\_\_ day of \_\_\_\_\_, 2022.  
Weber County Surveyor  
Record of Survey #  
WCO 106 - 1 - 8(c)(1)h.10; WCO 45 - 4 - 2(c)

CURVE	LENGTH	RADIUS	DELTA ANGLE	CHORD BEARING	CHORD LENGTH
C1	24.49	15.50	90°31'35"	N43°58'05"W	22.02
C2	24.36	15.50	90°03'12"	N45°44'32"E	21.93
C3	24.33	15.50	89°56'10"	N44°15'09"W	21.91
C4	24.36	15.50	90°03'50"	S45°44'51"W	21.93
C5	24.28	15.50	89°44'35"	S44°21'35"E	21.87
C6	24.20	15.50	89°28'25"	N46°01'55"E	21.82

IS THE PURPOSE OF THIS AMENDMENT TO CREATE TWO OPEN SPACES INSTEAD OF ONE?  
IS THERE 27 OR 28 LOTS?

**WEBER COUNTY ATTORNEY**  
I have examined the financial guarantee and other documents associated with this subdivision plat and in my opinion they conform with the County Ordinance applicable thereto and now in force and effect.  
Signed this \_\_\_\_\_ day of \_\_\_\_\_, 2022.  
County Attorney

**WEBER COUNTY SURVEYOR**  
I hereby certify that the Weber County Surveyor's Office has reviewed this plat and all conditions for approval by this office have been satisfied. The approval of this plat by the Weber County Surveyor does not relieve the Licensed Land Surveyor who executed this plat from the responsibilities and/or liabilities associated therewith.  
Signed this \_\_\_\_\_ day of \_\_\_\_\_, 2022.  
Weber County Surveyor

**WEBER COUNTY PLANNING COMMISSION APPROVAL**  
This is to certify that this subdivision plat was duly approved by the Weber County Planning Commission on the \_\_\_\_\_ day of \_\_\_\_\_, 2022.  
Chairman, Weber County Planning Commission

**AGRICULTURAL NOTE**  
Agriculture is the preferred use in the agriculture zones. Agricultural operations as specified in the Land Use Code for a particular zone are permitted at any time including the operation of farm machinery and no allowed agricultural use shall be subject to restrictions on the basis that it interferes with activities of future residents of this subdivision.

**WEBER COUNTY ENGINEER**  
I hereby certify that the required public improvement standards and drawings for this subdivision conform with County standards and the amount of the financial guarantee is sufficient for the installation of these improvements.  
Signed this \_\_\_\_\_ day of \_\_\_\_\_, 2022.  
Weber County Surveyor

**WEBER COUNTY COMMISSION ACCEPTANCE**  
This is to certify that this subdivision plat, the dedication of streets and other public ways and financial guarantee of public improvements associated with this subdivision, thereon are hereby approved and accepted by the Commissioners of Weber County, Utah this \_\_\_\_\_ day of \_\_\_\_\_, 2022.  
Chairman, Weber County Commission  
Attest:  
Title:

**SURVEYOR'S NOTES NARRATIVE**

- The purpose of this survey was to subdivide part of parcel 15-078-0110 into 27 lots.
- The basis of bearing is S 89°13'14" E between the West Quarter Corner and East Quarter Corner of Section 28, Township 6 North, Range 2 West, Salt Lake Base and Meridian.
- The south line was established along the south line of the Southwest Quarter of said Section 28. The north right of way line of 2200 South Street was established 33' north and parallel with said quarter section line. This line lines up with the right of way line of the Boyd Russell Subdivision, 1st Amendment recorded in the Weber County Recorder's office under Entry 2841599 on February 8, 2017. The west line of the subdivision was established along the east line of the said Boyd Russell Subdivision, 1st Amendment, Boyd Russell Subdivision was established using section control and found rebar as shown.

**GENERAL NOTES**

- All Public Utility Easements shown as dashed lines shall be 10.00 foot wide unless otherwise indicated.
- Rebar to be set at all rear property corners. Curb pins to be set at lot line projections along streets.
- All development within this subdivision is subject to the requirements of Section 108-16 "Outdoor Lighting" of the Weber County Land Use Code.
- Street trees of a species determined by Weber County Policy are required every 50 feet on both sides of the street within the subdivision boundary. In the event infrastructure or a driveway approach makes a tree's placement impossible, that tree shall be located as close to 50-foot spacing as otherwise reasonable possible, provided compliance with the clear view triangle as defined in Section 108-7-7 of Weber County Land Use Code.
- This is a high water table area and no basements are allowed unless approved by Geotechnical Engineer and County. Lowest inhabitable floor shall be minimum of one foot above historical ground water level.

**SURVEYOR'S CERTIFICATE**  
I, Brian G. Lyon, a Registered Land Surveyor, hold Certificate No. 275617, in the State of Utah in accordance with Title 58, Chapter 22, Professional Engineers and Land Surveyors Act; and I have completed a survey of the property described on this plat in accordance with Section 17-23-17 and have verified all measurements, and have placed monuments as represented on this plat, and have hereby subdivided said tract into twenty-eight (28) lots, known hereafter as TAYLOR LANDING PHASE 1A, 1st AMENDMENT, located in Pleasant View City, Weber County, Utah and has been correctly drawn to the designated scale and is true and correct representation of the herein described lands included in said subdivision, based upon data compiled from records in the Weber County Recorder's Office and from said survey made by me on the ground.

PROFESSIONAL LAND SURVEYOR  
275617  
BRIAN G. LYON  
2/1/22  
STATE OF UTAH

**BOUNDARY DESCRIPTION**  
Part of the East Half of the Northwest Quarter of Section 28, Township 6 North, Range 2 West of the Salt Lake Base and Meridian described as follows:  
Commencing at the West Quarter Corner of Section 28, Township 6 North, Range 2 West of the Salt Lake Base and Meridian monumented with a Brass Cap, thence S 89°13'14" E 2224.08 feet along the south line of the Northwest Quarter of said Section 28 to the POINT OF BEGINNING and running  
thence N 00°46'08" E 1,001.00 feet along the east line of Boyd Russell Subdivision, 1st Amendment and it's projection thereof;  
thence S 89°13'14" E 17.26 feet;  
thence N 00°46'08" E 132.54 feet;  
thence N 00°34'29" W 66.02 feet;  
thence N 00°46'46" E 130.00 feet;  
thence S 89°13'14" E 284.00 feet;  
thence N 00°46'46" W 130.00 feet;  
thence S 17°35'31" W 68.95 feet;  
thence S 00°42'56" W 909.58 feet;  
thence S 02°28'17" E 96.65 feet;  
thence S 00°46'08" W 127.46 feet to the south line of the Northwest Quarter of said Section 28;  
thence N 89°13'14" W 286.05 feet along said south line to the point of beginning, containing 8.52 acres, more or less.

**OWNER'S DEDICATION**  
Know all by these presents that the undersigned owners of the above-described tract of land, having caused the same to be subdivided into lots and streets to hereafter be known as TAYLOR LANDING, PHASE 1A, 1st AMENDMENT  
Do hereby dedicate to public use all those parts or portions of said tract of land designated as streets, the same to be used as public thoroughfares.  
Grant and dedicate a perpetual right and easement over, upon and under the lands designated hereof as public utility, drainage easements and canal maintenance easement, the same to be used for the installation maintenance and operation of public utility service lines, storm drainage facilities, irrigation canals for the perpetual preservation of water channels in their natural state whichever is applicable as may be authorized by the governing authority, with no buildings or structures being erected within such easements.  
Grant and convey to the subdivision lot owners association Common Area "A" to be used for recreational and open space purposes for the benefit of each lot owners association member in common with all others in the subdivision or grant and dedicate to the county a perpetual open space right and easement on and over Common Area "A" to guarantee to Weber County that the common area remain open and undeveloped except for approved recreational, parking and open space purposes.  
Dedicate and convey to Weber County a perpetual open space easement on, under, and over all parcels and areas denoted as open space parcels or areas to guarantee to the public that those parcels and areas remain open and undeveloped except for approved open space purposes.  
In witness whereof, we have hereunto set our hands this \_\_\_\_\_ day of \_\_\_\_\_, 2022.

\_\_\_\_\_, Manager  
Land Development LC  
Spencer Stephens, Manager  
Spencer Stephens Construction, LLC

**LIMITED LIABILITY ACKNOWLEDGEMENT**  
STATE OF UTAH } ss  
COUNTY OF \_\_\_\_\_ } ss  
On this \_\_\_\_\_ day of \_\_\_\_\_ A.D. 2022, personally appeared before me, \_\_\_\_\_ who being by me duly sworn did say, for himself that he is the Manager of Spencer Stephens Construction, LLC, a Utah Limited Liability Company, and that the within and foregoing instrument was signed on behalf of said Limited Liability Companies.  
MY COMMISSION EXPIRES \_\_\_\_\_ NOTARY PUBLIC RESIDING AT \_\_\_\_\_

**LIMITED LIABILITY ACKNOWLEDGEMENT**  
STATE OF UTAH } ss  
COUNTY OF \_\_\_\_\_ } ss  
On this \_\_\_\_\_ day of \_\_\_\_\_ A.D. 2022, personally appeared before me, \_\_\_\_\_ who being by me duly sworn did say, for himself that he is the Manager of Land Development LC, a Utah Limited Liability Company, and that the within and foregoing instrument was signed on behalf of said Limited Liability Companies.  
MY COMMISSION EXPIRES \_\_\_\_\_ NOTARY PUBLIC RESIDING AT \_\_\_\_\_

**COUNTY RECORDER**  
State of Utah, County of Weber, recorded and filed at the request of \_\_\_\_\_ Date \_\_\_\_\_ Time \_\_\_\_\_ Fee \_\_\_\_\_ Entry \_\_\_\_\_  
Index  
Filed in: File of plots \_\_\_\_\_ County Recorder

**TAYLOR LANDING PHASE 1A  
1st AMENDMENT  
A CLUSTER SUBDIVISION**

ALLIANCE CONSULTING ENGINEERS  
150 EAST 200 NORTH SUITE P  
LOGAN, UTAH 84321  
(435)755-5121  
alliancelogan@yahoo.com

Developer: Development Heritage Land LLC 700 84337 Tremonton, Utah

REVISIONS / SUBMISSIONS	DATE

DRAWN: \_\_\_\_\_ PROJECT NO.: \_\_\_\_\_  
REVIEWED: \_\_\_\_\_

**TAYLOR LANDING PHASE 1A  
1st AMENDMENT  
A CLUSTER SUBDIVISION**  
PART OF THE NORTHWEST QUARTER OF SECTION 28, TOWNSHIP 6 NORTH, RANGE 2 WEST, SALT LAKE BASELINE AND MERIDIAN WEBER COUNTY, TAYLOR, UTAH  
**FINAL PLAT**

**TAYLOR LANDING PHASE 1A,  
1st AMENDMENT  
A CLUSTER SUBDIVISION**  
PART OF THE NORTHWEST QUARTER OF SECTION 28,  
TOWNSHIP 6 NORTH, RANGE 2 WEST,  
SALT LAKE BASELINE AND MERIDIAN  
WEBER COUNTY, UTAH  
**FINAL PLAT  
FEBRUARY 2022**

**OPEN SPACE PHASE I BOUNDARY DESCRIPTION**  
Part of the East Half of the Northwest Quarter of Section 28, Township 6 North, Range 2 West of the Salt Lake Base and Meridian described as follows:  
Commencing at the West Quarter Corner of Section 28, Township 6 North, Range 2 West of the Salt Lake Base and Meridian monumented with a Brass Cap; thence S 89°13'14" E 2224.08 feet along the south line of the Northwest Quarter of said Section 28; thence N0°46'08" E 1001.00 feet; thence S 89°13'14" E 17.26 feet; thence N 00°46'08" E 132.54 feet; thence N 00°34'29" W 66.02 feet; thence N 00°46'46" E 130.00 feet; N89°13'14" W 362.04 feet to the POINT OF BEGINNING and running thence N 89°13'14" W 594.10 feet; thence N 00°48'18" E 100.00 feet; thence N 11°33'40" E 213.77 feet; thence N 00°49'48" E 353.36 feet to the Southeast Corner of Belmont Park Estates Subdivision, Phase 3; thence N 00°46'11" E 664.28 feet to the north line of the Northwest Quarter of said Section 28; thence S 89°07'58" E 314.43 feet along said north line; thence S 00°52'02" W 768.77 feet; thence S 89°32'33" E 236.27 feet; thence S 00°20'03" W 559.74 feet to the point of beginning, containing 12.81 acres, more or less.

**NOTES:**  
TAYLOR LANDING OVERALL SUBDIVISION  
TOTAL AREA: 109.63 ACRES  
PUBLIC R-O-W: 13.39 ACRES  
NET DEVELOPABLE GROUND: 96.08 ACRES  
NET OPEN SPACE: 55.97 ACRES (58.25%)  
PHASE 1 (INCLUDES PH1A AND FUTURE PH1B)  
TOTAL AREA: 12.80 ACRES  
PUBLIC R-O-W: 3.84 ACRES  
NET DEVELOPABLE GROUND: 8.96 ACRES  
NET OPEN SPACE: 12.81 ACRES (58.25%)

**ALLIANCE CONSULTING ENGINEERS**  
150 EAST 200 NORTH SUITE P  
LOGAN, UTAH 84321  
(435)755-5121  
alliance@ace-engineers.com

Developer: Heritage Land Development  
Tremonton, Utah 84337

NO.	REVISIONS/SUBMISSIONS	DATE

REVIEWED: \_\_\_\_\_ DRAWN: \_\_\_\_\_ PROJECT NO.: \_\_\_\_\_  
CAD FILE: \_\_\_\_\_

**TAYLOR LANDING PHASE 1A  
1st AMENDMENT  
A CLUSTER SUBDIVISION**  
PART OF THE NORTH HALF OF SECTION 28, TOWNSHIP 6  
NORTH, RANGE 2 WEST,  
SALT LAKE BASELINE AND MERIDIAN  
WEBER COUNTY, UTAH  
**FINAL PLAT**

DATE: FEB, 2022  
DRAWING No. **2**  
2 of 2

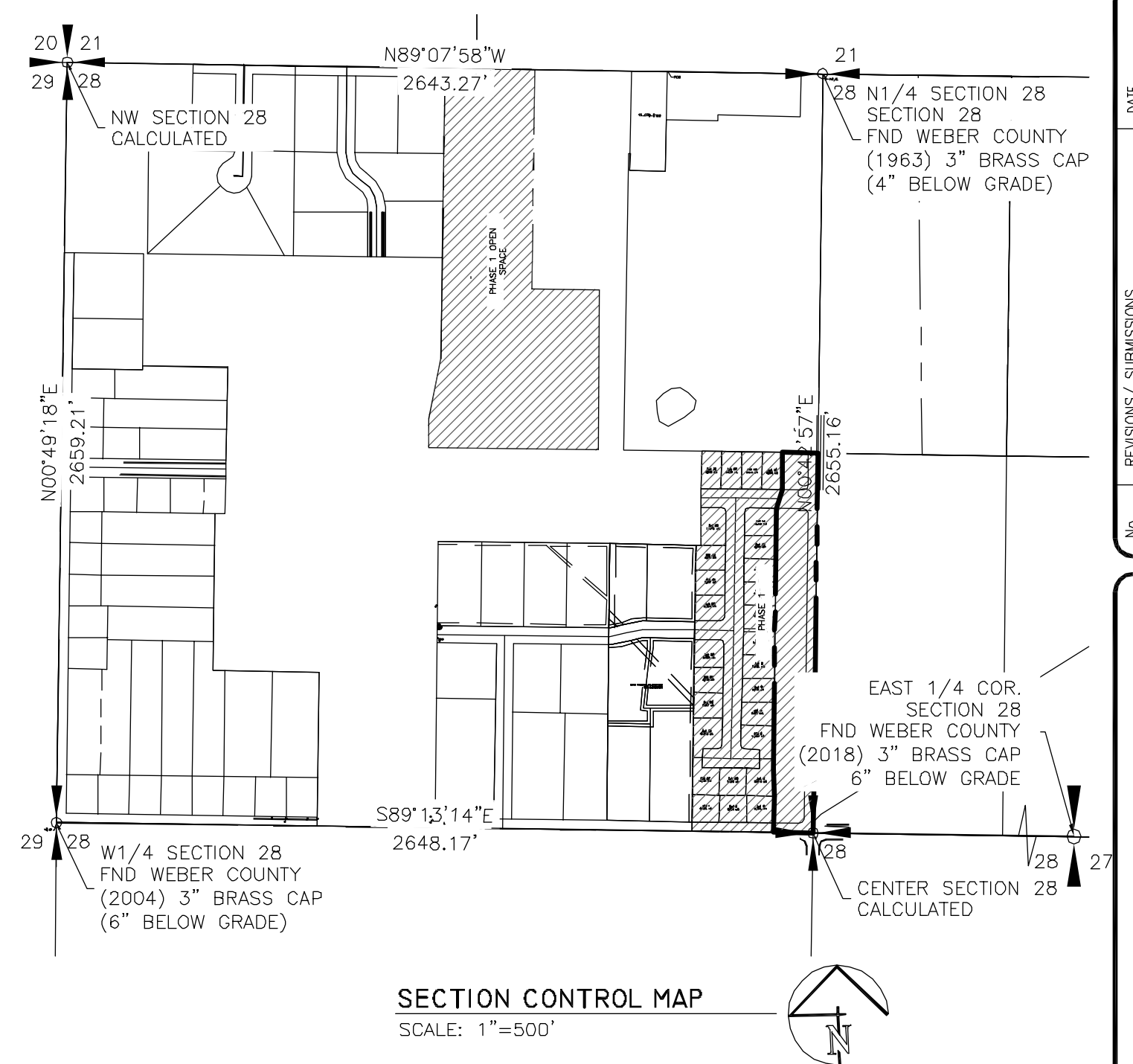
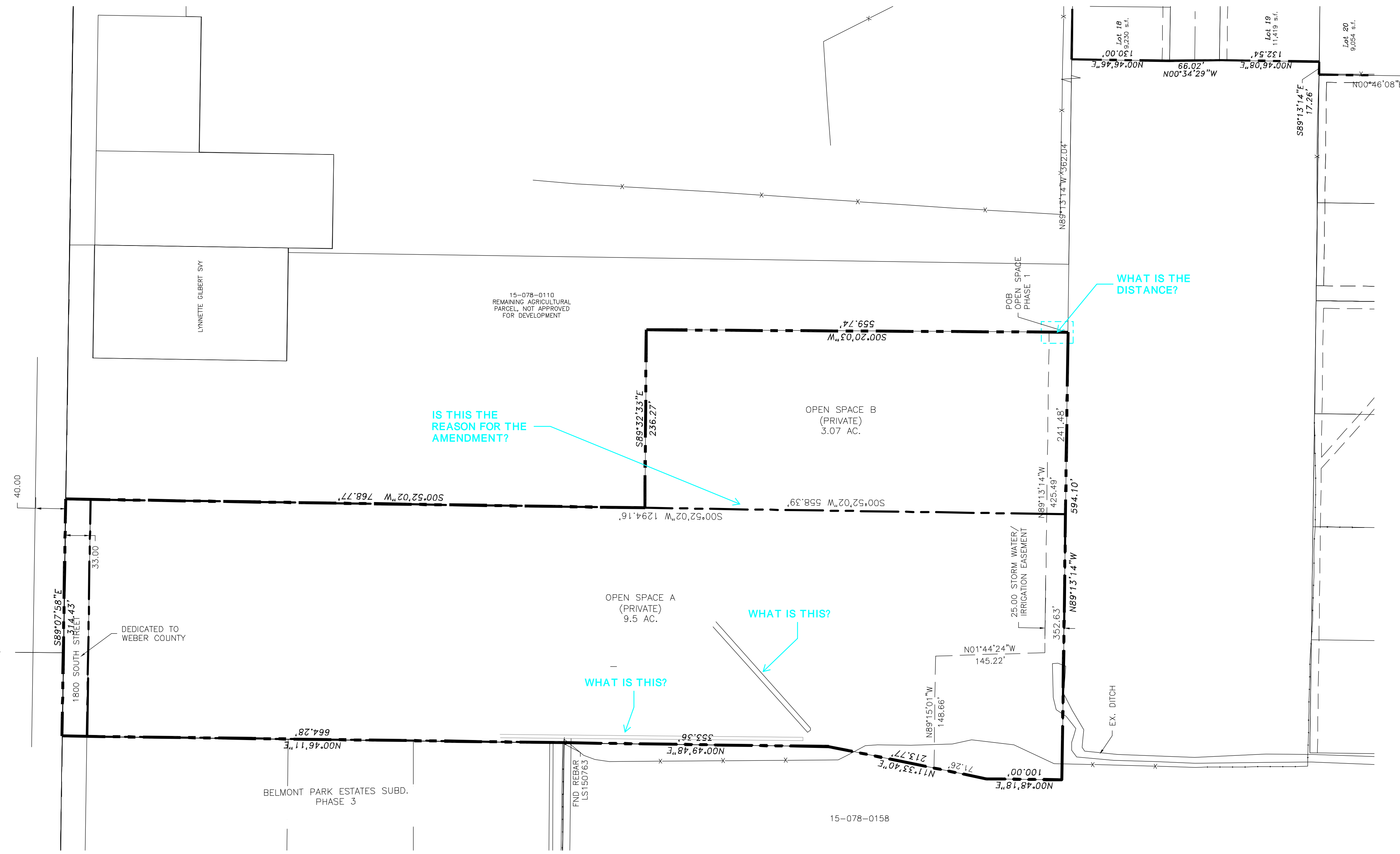
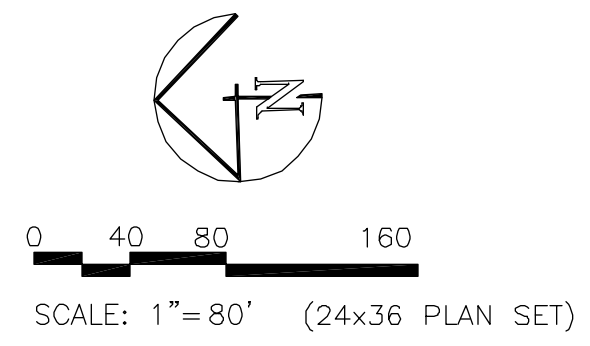

**COUNTY RECORDER**  
State of Utah, County of Weber, recorded and filed at the request of \_\_\_\_\_  
Date \_\_\_\_\_ Time \_\_\_\_\_ Fee \_\_\_\_\_  
Entry \_\_\_\_\_  
Index \_\_\_\_\_  
Filed in: File of plats \_\_\_\_\_ County Recorder \_\_\_\_\_