



Central Weber Sewer Improvement District

Sewer Manhole and Service Connection Standards

March 2018

GENERAL NOTES

1. All connections made to Central Weber Sewer Improvement District (District) owned sewer mains shall be done in accordance with these standards.
2. Plans shall be coordinated with the District at least 3 weeks prior to beginning work. The District can be contacted at 801-731-3011. Submission of connection plans to the District will be required. The submitted plans shall identify the location and type of connection. The connection details can refer to these standards, however, any substitution or deviation from these standards must be coordinated and approved by the District.
3. For trench backfill above pipe zone and surface restoration requirements and coordination, see Sanitary Sewer Manhole standards.
4. **New Pipe Connection to Existing Sewer Main:**
 - A. If grade allows, new pipe connections shall match the 0.75 depth point of existing sewer main. Otherwise match top of new pipe connection to top of existing sewer main as approved by the District Engineer.
 - B. Inverts shall be full depth.
5. Debris and construction materials shall not be allowed to enter the existing wastewater system. If debris and construction materials do enter the existing wastewater system, the Contractor shall be responsible for removal of the material, and any damages caused thereby, as approved by the District Engineer.
6. Contact District Inspector 48 hours (2 business days) prior to construction.
7. All sewer construction connected to District owned sewer mains shall be approved by the District Inspector prior to completion of the work.
8. Contractor may submit equal products and materials in lieu of those specified in these standards for review and approval by the District.

SANITARY SEWER MANHOLE (DETAIL D-1)

1. GENERAL

- A. The drawing shows typical pipe connections. Refer to construction drawings for connection locations or refer to field location of existing piping when engineering pipe connection to the manhole.
- B. **Manhole Size:**
 - 1) **Diameter is 5 feet:** For sewer pipes between 15" and 18" diameter.
 - 2) **Diameter is 6 feet:** For sewer pipes between 21" and 36" diameter.
 - 3) **Diameter is 7 feet:** For sewer pipes 36" diameter and larger. Coordinate with District Engineer for larger sewer pipes.

2. PRODUCTS

A. Surface Restoration:

- 1) Pavement Restoration: Shall be in accordance with the applicable City, County, District or State standards, permits, and/or as designated on Construction Drawings that have been reviewed and approved by the District.
- 2) Other Surface Restoration: As designated on Construction Drawings that have been reviewed and approved by the District.

B. Trench Backfill Above Pipe Zone Material: Backfill material in public or private roads and parking lots, streets and rights-of-way shall meet one of the following requirements, whichever is more stringent, when tested in accordance with ASTM D 2487:

- 1) Material meeting the requirements of applicable City, County, District or State standards and permits.
- 2) Native or import material graded, free of lumps and rocks larger than 3 inches, organic material and debris, with not more than 20% passing a 200 sieve.
- 3) Pea gravel, squeegee, or recycled RAP aggregate materials shall not be used as trench backfill material.

C. Pipe Zone Material: Manufactured, angular, crushed stone or rock, meeting the following gradation and free from organic matter when tested in accordance with ASTM D 2487:

	Open Graded	Dense Graded
US Standard Sieve	Percent Passing	
1 ½"	100	100
¾"	95-100	95-100
#4	0-10	10-50
200	0-5	0-5

- 1) Pea gravel, squeegee, or recycled RAP aggregate materials shall not be used as pipe zone material.

D. Cone, Sections and Base:

- 1) Precast meeting Class 4000 psi concrete, ASTM C478.
- 2) Apron: Minimum 2% cross-slope.
- 3) Joints: Tongue and groove type specifically designed for type of joint sealant material being used.
- 4) Precast base sections shall be monolithically poured.
- 5) Cone sections shall be of the eccentric type.

E. Reinforcement: Deformed, 60 ksi yield grade steel, ASTM A615.

F. Grade Rings (Type as approved by District Engineer)

- 1) Concrete:
 - a. Precast reinforced concrete conforming to ASTM C478.
 - b. Designed to meet H-20 live loading.
 - c. Size: 6"
- 2) Polypropylene:
 - a. Pro-Ring™ as manufactured by Cretex Specialty Products
 - b. Designed to meet H-20 live loading.

- c. Sizes: 2", 4" and 6"
- 3) **Thermoplastic Riser Form:**
 - a. As manufactured by Whirlygig™
 - b. Sealant: One-compound, all purpose, polyurethane sealant. Sikaflex™ Construction Sealant as manufactured by Sika Chemical or Dynatrol™ I-XL as manufactured by Pecora Corporation.
 - c. Sizes: 4", 7", 11" and 15"
- G. Frame and Cover:
 - 1) Cast iron conforming to ASTM A48 Class 35B.
 - 2) **Manufactured by D&L Supply, model A-1180.**
 - 3) Cast the words "SEWER" on the cover in upper case flush with the surface finish
 - 4) Non-vented with closed-pick hole for removal, in landscape areas.
 - 5) Vented with closed-pick hole for removal, in roadway areas.
- H. Steps:
 - 1) Conform to ASTM C478
 - 2) ½" deformed grade 60 steel reinforcing rod encased in polypropylene conforming to ASTM 2146, Type II, Grade 16906.
- I. Flexible Pipe Connector (Boot):
 - 1) Conform to ASTM C-923
 - 2) Manufactured and sized specifically for the type and size of piping connecting to manhole. Refer to construction drawings.
 - 3) Kor-N-Seal™ as manufactured by Trelleborg or PSX:Direct Drive as manufactured by Press-Seal Gasket Corporation.
- J. Pipe to Manhole Adapter:
 - 1) "Romac style 'LCT' Manhole Adapter Gasket" as manufactured by Romac Industries, Inc., Fernco large diameter waterstop or manhole adapter as manufactured by Fernco, Inc.
 - 2) Type 316 stainless steel band clamp with fastener.
- K. Joint Sealant:
 - 1) Performed flexible joint sealant (mastic) meeting requirements of ASTM C990.
 - 2) Ram-Neck as manufactured by Henry Company Sealants Division, Kent Seal as manufactured by Hamilton Kent, or Polysealant as manufactured by J-K Polysource, Inc.
 - 3) External Wrap: 12" wide External Joint Wrap M-860 as manufactured by J-K Polysource.
- L. Concrete: Class 4000: 28-day minimum compressive strength of 4000 psi and contain not less than 6 ½ bags of low alkali, Type II or Type V Portland Cement per cubic yard and air entrainment per ASTM C-150.
- M. Grout:
 - 1) Cementitious: High strength, non-shrink, non-metallic, cement based grout.
 - 2) Epoxy: High strength, non-shrink, 100% solids, 3 component epoxy grout system.
- N. Invert Cover: 5/8" thick exterior grade plywood.
- O. Plugs:
 - 1) Muni-Ball Pneumatic Plug with retainer.
 - 2) Burke Duo Seal Pipe Plugs as supplied by Burke Rubber Company.

3. EXECUTION

A. Plug:

- 1) Install temporary plug in outlet of downstream manhole as needed until construction is complete.
- 2) Remove debris and plug from inside of manhole after all grading around manhole has been completed and final surfacing is in place.
- 3) Stubs for future connections shall be plugged until activation for service is approved by District Engineer.

B. Pipe Zone Material Placement: Material shall be placed, leveled and compacted to 96% or greater of the Modified Proctor Density as determined by the compaction control test specified in ASTM D1557 and verified by ASTM D1556 or D2922 prior to placing the manhole base.

C. Manhole Bases:

- 1) Placed so as to fully and uniformly support proper horizontal and vertical alignment.
- 2) Installation of pipe in manhole base with flexible pipe connector (boot) shall be per manufacturer's recommendations and standards. Hold boot in place with stainless steel band clamps.
- 3) Installation of pipe in manhole base where a flexible pipe connector (boot) is not possible, as approved by the District Engineer, shall include a pipe to manhole adapter placed around the pipe and centered on the manhole wall and grouted with non-shrink grout to form a watertight seal.
- 4) Grout around all pipe connection openings with non-shrink grout.

D. Wall and Cone Sections: Placed and aligned to provide vertical sides.

E. Finish: Provide smooth and neat finishes on interior of cones, shafts and rings. Imperfect moldings or honeycombs will not be accepted.

F. Steps:

- 1) Uniform vertical spacing for entire depth of manhole with a maximum 12" vertical spacing between steps.
- 2) Vertically aligned with less than 1" deviation.
- 3) 12" maximum vertical distance from top of cone to center of top step.
- 4) 30" maximum vertical distance from top of frame and cover to center of top step.
- 5) 24" maximum, 12" minimum vertical distance from center of bottom step to manhole apron.
- 6) Located over the largest apron of the manhole base unless otherwise approved by the District Engineer.

G. Joints:

- 1) Place joint sealant (mastic) in all riser joints according to manufacturer's recommendations and standards. Grouted joints shall not be used.
- 2) Mastic shall be installed when the temperature of the material is above 70 degrees to assure a water tight seal. Heating of material may be required to achieve a proper seal.
- 3) In areas of high groundwater, joints shall be wrapped on the exterior of the manhole with external wrap per manufacturer's recommendations and standards.

H. Invert Cover:

- 1) Install invert cover over manhole shelf.
- 2) Do not interfere with flow in pipeline.

- 3) Secure all pieces of each invert cover together.
 - 4) Remove debris and invert cover from inside of manhole after all grading around manhole has been completed and final surfacing is in place.
- I. Trench Backfill Above Pipe Zone Material:
- 1) All trench backfilling above pipe zone material shall be in accordance with the most stringent of the applicable City, County, District or State standards, permits, or the following:
 - a. Trench backfill material shall meet the requirements of paragraph 2B of the Sanitary Sewer Manhole (Detail D-1) standards.
 - b. Suitable backfill material shall be placed in maximum 8" lifts and compacted to 96% in public or private roads and parking lots, streets and rights-of-way and to 91% for off-road, landscape or unimproved areas of the Modified Proctor Density as determined by the compaction control test specified in ASTM D-1557 and verified by ASTM D-1556 or ASTM D-2922.
 - c. If existing material does not meet paragraph 2B of the Sanitary Sewer Manhole (Detail D-1) standards or cannot meet compaction requirements, acceptable import material will be required.
 - 2) Backfilling shall be accomplished in a manner to prevent damage or disturbance to the installed manhole.
 - 3) Manhole sections disturbed during backfilling shall be removed, rejointed and restacked.
 - 4) Manhole sections damaged during construction shall be replaced with new sections.
- J. Manhole Testing:
- 1) A vacuum test shall be performed on each manhole installed unless otherwise directed by the District Engineer.
 - 2) District Inspector shall witness all manhole vacuum testing.
 - 3) Each manhole shall be tested to the top of the cone section. Final manhole adjustment to grade does not have to be included in the test.
 - 4) Manholes shall be tested, by an independent testing company, using vacuum test method to demonstrate integrity of installed materials and construction procedures. Method and material for repair shall be as acceptable to the District Inspector.
 - a. Notify District Inspector 48 hours prior to any testing.
 - b. Each manhole shall be tested after assembly and backfilling.
 - c. Plug all lift holes and other incidental penetrations with an acceptable non-shrink grout.
 - d. Plug all pipes entering manhole; securely brace plugs during test. In spite of bracing requirements, plugs shall resist internal test pressures without requiring external bracing or blocking.
 - e. Manhole shall be clean and dry at time of test.
 - f. Test head shall be placed at inside top of cast iron frame, or as accepted by District Inspector; and the seal shall be inflated in accordance with manufacturer's recommendations.
 - g. Testing shall be in accordance with ASTM C 1244, with a vacuum of 10 in Hg drawn on the manhole and test time required for vacuum to drop to 9 in Hg shall exceed the time required in Table 1.

- h. All defects indicated by an unsuccessful “vacuum test” shall be corrected by restacking of the manhole with joint gasket or manhole section replacement as necessary to achieve a successful test. The test shall be repeated until the successful performance of a “vacuum test” is achieved. Joint repairs are not acceptable.
- i. The results of the “vacuum test” for each manhole shall be documented and submitted to the District Inspector. Acceptance, failures, reasons for failure, and retests shall be shown in the documentation.
- j. Manholes shall be constructed to a watertight condition. Any leaks, seeps, or other infiltration of water shall be corrected as approved by the District Inspector.
- k. Manholes shall be cleaned to remove all dirt, gravel, dust, asphalt, and other debris from all surfaces prior to placing the new manhole in service.

**Table 1
Minimum Test Times for Various Manhole Diameters**

Depth	Manhole Diameter (in)																
	30	33	36	42	48	54	60	66	72	78	84	90	96	102	108	114	120
<4	6	7	7	9	10	12	13	15	16	18	19	21	23	24	25	27	29
6	9	10	11	13	15	18	20	22	25	26	29	31	34	36	38	41	43
8	11	12	14	17	20	23	26	29	33	35	38	41	45	48	51	54	57
10	14	15	18	21	25	29	33	36	41	44	48	52	56	60	63	67	71
12	17	18	21	25	30	35	39	43	49	53	57	62	67	71	76	81	85
14	20	21	25	30	35	41	46	51	57	62	67	72	78	83	89	94	100
16	22	24	29	34	40	46	52	58	67	70	76	83	89	95	101	108	114
18	25	27	32	38	45	52	59	65	73	79	86	93	100	107	114	121	128
20	28	30	35	42	50	53	65	72	81	88	95	103	111	119	126	135	142
22	31	33	39	46	55	64	72	79	89	97	105	114	122	131	139	148	156
24	33	36	42	51	59	64	78	87	97	106	114	124	133	143	152	161	170
26	36	39	46	55	64	75	85	94	105	114	124	134	144	155	184	175	185
28	39	42	49	59	69	81	91	101	113	123	133	145	155	167	177	188	199
30	42	45	53	63	74	87	98	108	121	132	143	155	166	178	189	202	213

5) Failed Test Correction:

- a. Notify District Inspector of test failure.
- b. Locate leak or defect location, expose and identify defect.
- c. Contact the District Inspector for approval of the proposed correction procedures.
- d. Evaluation is on a case-by-case basis.
- e. For Damaged or Defective Manholes:
 - I. Remove and replace the defective section(s), joint sealant material or other defective feature and re-stack the manhole.
 - II. Joint repairs using supplemental sealants or surface grouting of wall sections without removing the sections are not acceptable repair methods and shall not be approved.

K. Surface Restoration:

- 1) Pavement Restoration: Shall be in accordance with the applicable City, County, District or State standards, permits, and/or as designated on Construction Drawings that have been reviewed and approved by the District.
 - 2) Other Surface Restoration: As designated on Construction Drawings that have been reviewed and approved by the District.
- L. Adjustment:
- 1) Manhole raised to final grade after final surface paving or grading.
 - 2) Distance from top of cone to top of frame and cover shall generally not exceed 18". Distances greater than 18" require specific approval from District Engineer. In no case shall the distance exceed 24". Distances greater than approved will require the addition of a manhole wall section and retesting.
 - 3) Distance from top of cone to lowest point on bottom of frame shall not be less than 4".
 - 4) In Paved Areas:
 - a. Top of manhole frame and cover shall be between 1/8" and 1/4" below and parallel to the plane of the paving at the outside edge of the collar.
 - b. Prior to paving, a circular metal plate or cover shall be placed on top of cone temporarily to prevent material from entering manhole.
 - c. Block out area around manhole adequate for manhole adjustment in concrete pavement areas.
 - 5) In Landscape Areas: Top of manhole frame and cover shall be set 6" above finished grade or as directed by the District Engineer.
 - 6) Grade Rings: (Type as approved by District Engineer)
 - a. Concrete or Polypropylene:
 - I. Install per manufacturer's recommendations and standards.
 - II. Joints between cone and bottom grade ring, between grade rings and between the top grade ring and the frame shall be made by placing mastic around the midpoint of the cone or grade ring, placing the next grade ring or frame and applying pressure to distribute the mastic material and form a watertight seal.
 - III. Mastic shall be installed when the temperature of the material is above 70 degrees to assure a water tight seal. Heating of material may be required to achieve a proper seal.
 - b. Thermoplastic Riser Form:
 - I. Install per manufacturer's recommendations and standards.
 - II. Set thermoplastic riser form in a bead of sealant to achieve a watertight seal between form and top of cone.
 - III. Riser form shall be anchored to the manhole cone with a minimum of 4 anchors. Care shall be taken while anchoring the form to prevent damage to top of cone. Proposed alternate methods to assure that the form does not become displaced during placement of concrete will be considered and require approval from the District Engineer prior to implementation.
 - c. Metal Adapter Rings (Risings): Metal adapter rings (risings) shall not be used for final adjustment of the frame and cover on new development projects.
 - 7) Concrete Collar:

- a. In Asphalt Paved Areas: After final lift of asphalt is placed, the asphalt and base course material shall be removed to a diameter to accommodate a 1-foot concrete collar around the frame and cover and to a level of 12" below top of frame and cover and 6" outside the cone. The edge of the asphalt shall be smooth and uniform.
- b. In Concrete Paved Areas: After concrete pavement is placed, the base course material shall be removed to a diameter a minimum of 30" greater than the diameter of the top of the manhole frame and to the level of 12" below top of frame and cover and 6" outside the cone.
- c. Concrete shall be placed and consolidated in the excavated area around the cone, riser form and frame after frame has been set to final grade.
- d. In paved areas, concrete shall be allowed to cure a minimum of three days prior to allowing traffic over the manhole.

CAST-IN-PLACE MANHOLE BASE (DETAIL D-2)

1. GENERAL

- A. The following notes are in addition to those that apply found listed under the Sanitary Sewer Manhole standards.
- B. Cast-in-place manhole shall be approved by the District Engineer prior to construction and shall include a precast wall section with a cast-in-place invert.
- C. If possible, cast-in-place base shall be located at the approximate midpoint of an individual pipe section on the existing main line in order to avoid including a joint of the existing pipeline within the new manhole base.
- D. Any portion of the existing pipe damaged shall be repaired or replaced by the Contractor at the Contractor's expense and as approved by the District Engineer.

2. PRODUCTS

- A. Expandable Waterstop:
 - 1) Composite bentonite clay based or expandable rubber based waterstop designed to create watertight joints in concrete.
 - 2) Hydrotite as manufactured by Greenstreak, Superstop as manufactured by Tremco, Mirastop as manufactured by Carlisle Coatings and waterproofing.
- B. Block: 8" x 8" x 16" standard solid concrete block.
- C. Doghouse Base:
 - 1) Precast concrete wall section cutout to span the existing pipe.
 - 2) Precast meeting Class 4000 psi concrete, ASTM C478.

3. EXECUTION

- A. Excavation: Material around existing pipe shall be removed to a level that is even with the bottom of the existing pipe. The material even with and below the existing pipe shall be left undisturbed. After excavation, the remaining subgrade shall be compacted and prepared for manhole base.
- B. Blocks:
 - 1) Precast wall section shall be supported on concrete block and adjusted to proper alignment and grade prior to pouring the invert.
 - 2) Blocks shall be positioned to not interfere with the coring of the base for placement of the new pipe and shall not be exposed in the finished manhole base.
- C. Doghouse Base:
 - 1) Precast wall section shall not bear directly on the existing pipe.
 - 2) Adequate separation between any part of the precast wall section and the existing pipe shall be provided to allow for placement of the pipe and manhole adapters and to provide a minimum of 3" thickness of concrete between the pipe and the wall section.
 - 3) Prior to placing base, the outside of the existing pipe shall be cleaned and pipe to manhole adapters (2 per side) shall be installed on the existing pipe. Each adapter is cut at a single location and wrapped around the existing pipe and secured/fastened to pipe using a Type 316 stainless steel band clamp with fastener. Verify that each adapter is firmly pressed against the existing pipe for a watertight connection.

- 4) Prior to placing concrete, a circular form extending from the prepared subgrade to a minimum of 12" above the highest pipe entering the manhole shall be installed and anchored. If used, the form shall be a minimum of 12" greater in diameter than the outside of the manhole section wall and shall be located concentric with the manhole base.

- 5) Concrete Invert:
 - a. Concrete invert shall be a continuous pour and shall meet the following requirements:
 - I. Concrete shall be poured to bottom of existing pipe or prepared subgrade and shall extend a minimum of 6" radially, measured from the outside of the precast manhole wall section.
 - II. Concrete on the outside of the manhole shall extend a minimum of 12" above the top of the highest pipe that will connect to base and shall be level.
 - III. Concrete on inside of manhole shall extend to top of the highest pipe that will connect to base.
 - IV. Concrete on inside of manhole shall be formed around the existing pipe to provide an invert in the manhole. The bottom half of the existing pipe will remain in place to form the bottom of the invert. The concrete above the existing pipe shall be formed to provide a uniform channel with vertical sides that matches the diameter of the pipe from springline to the top of pipe. In certain situations, extra depth of channel may be required to contain the wastewater flow in the channel.
 - V. Review pipe opening size with District Inspector prior to cutting top of existing pipe.
 - VI. The top half of existing pipe shall be sawcut and removed for the length approved by the District Inspector and to the springline of the pipe in the width after cast-in-place base has been completed and cured for a minimum of 48 hours and after the wall section cone and casting have been placed and tested.
 - VII. Rough edges of the pipe and concrete thus exposed shall be ground smooth and, if needed, grouted with epoxy grout in such a manner as to produce a smooth and acceptable finish.
 - VIII. Any gaps at the interface of the precast wall section and the cast-in-place concrete due to concrete shrinkage shall be grouted or sealed with epoxy grout as directed by the District Engineer.
 - IX. Apron: Minimum 2% slope.

- 6) New Pipe to Cast-in-Place Manhole Connection:
 - a. Manhole to be cored prior to placing concrete.
 - b. Install a flexible pipe connector (boot) in the core drilled base to provide a watertight seal. Install flexible pipe connector (boot) per manufacturer's recommendations and standards.
 - c. Additional forming of the core drilled invert by chipping and grouting may be required to provide a smooth transition to the existing invert.

CONNECTION TO EXISTING MANHOLE (DETAIL D-3)

1. GENERAL

- A. The following notes are in addition to those that apply found listed under the Sanitary Sewer Manhole standards.
- B. Connection to existing manhole shall be approved by the District Engineer prior to construction.
- C. Any portion of the existing manhole damaged shall be repaired or replaced by the Contractor at the Contractor's expense and as approved by the District Engineer.

2. PRODUCTS (NO ADDITIONAL PRODUCTS USED)

3. EXECUTION

- A. Existing Manhole Assessment: Prior to construction, condition of the existing manhole shall be assessed by the District Inspector.
 - 1) If Determined that the Manhole is Suitable to Core:
 - a. District Inspector shall witness all core drilling of existing manholes.
 - b. Contractor shall core drill existing manhole wall and apron as required with appropriate size coring machine to allow for placement of new pipe to flexible pipe connector (boot) in manhole at design elevation and provide a channel in the apron for new pipe.
 - c. Install flexible pipe connector (boot) in core drilled wall per manufacturer's recommendations and standards to provide a watertight seal.
 - d. Existing apron shall be built up with epoxy grout anchored to existing concrete with Type 316 stainless steel anchors or as otherwise directed by the District Engineer to provide a full depth channel from the new pipe to the existing channel as directed by the District Engineer.
 - e. Chipping, cutting and grinding of existing apron and channel and finishing with epoxy grout may be required.
 - f. Transition from new invert to existing invert shall be smooth and uniform and shall provide a long radius sweep to redirect flow to the existing downstream pipe.
 - 2) If Determined that the Manhole is Not Suitable to Core: Existing manhole shall be removed and replaced with a new manhole with precast base.
- B. During construction of new sewer line to existing manhole, the alignment of existing precast sections, grade rings, and castings shall be maintained and the joints between sections, grade rings, and casting, lift holes and connections of existing inflow and outflow pipes shall be watertight.
- C. Contractor shall provide for continuous wastewater flow and shall prevent entrance of any groundwater, storm water, debris or dirt into existing facilities during construction process.

OUTSIDE DROP MANHOLE (DETAIL D-4)

1. GENERAL

- A. The following notes are in addition to those that apply found listed under the Sanitary Sewer Manhole standards.
- B. Outside drop manhole connections shall be avoided in the design of the wastewater collection system and will require approval on a case by case basis by the District Engineer.
- C. Outside drop manhole connections shall be required whenever the elevation difference between the flowlines of the incoming pipe and the outgoing pipe, as calculated at the inside manhole wall, meets or exceeds 24".
- D. Incoming Pipe Sizes: For sewer pipes between 8" and 12" diameter.

2. PRODUCTS

- A. Pipe: Polyvinyl Chloride (PVC) pipe conforming to ASTM D 3034, SDR-35, smooth solid wall sewer pipe, bell and spigot joint ends with gaskets.
- B. Fittings:
 - 1) Polyvinyl Chloride (PVC) gasketed sewer fittings conforming to ASTM F-1336.
 - 2) Long sweep 90 degree bend is required, however, two 45 degree bends can be used to make 90 degree turns if approved by the District Inspector.
- C. Joints: Polyvinyl Chloride (PVC) integral-bell gasketed joints conforming to ASTM D3212. Rubber gaskets shall be factory installed and conform to ASTM F477.

3. EXECUTION

- A. Outside Drop Piping:
 - 1) Install drop piping with wye turned down at top of drop and two 45 degree bends to make 90 degree turn at bottom of drop.
 - 2) Place and compact a minimum of 6" pipe zone material around and along pipe between pipe at top of drop to a maximum of 6" above the top gasket joint of the top 45 degree fitting belonging to the 90 degree turn at the bottom of drop.
 - 3) Place and consolidate a minimum of 6" concrete around and along the pipe belonging to the 90 degree turn at the bottom of drop up to a minimum of 6" above the top gasket joint of the top 45 degree fitting of said turn.

INSIDE DROP MANHOLE (DETAIL D-5)

1. GENERAL

- A. The following notes are in addition to those that apply found listed under the Sanitary Sewer Manhole standards.
- B. Inside drop manhole connections shall be avoided in the design of the wastewater collection system and will require approval on a case by case basis by the District Engineer.
- C. Inside drop manhole connections shall be required whenever the elevation difference between the flowlines of the incoming pipe and the outgoing pipe, as calculated at the inside manhole wall, meets or exceeds 24".
- D. Incoming Pipe Sizes: For sewer pipes between 8" and 12" diameter.

2. PRODUCTS

- A. Pipe: Polyvinyl Chloride (PVC) pipe conforming to ASTM D 3034, SDR-35, smooth solid wall sewer pipe, bell and spigot joint ends with gaskets.
- B. Fittings:
 - 1) Polyvinyl Chloride (PVC) gasketed sewer fittings conforming to ASTM F-1336.
 - 2) 90 degree bends are not allowed. Two 45 degree bends shall be used to make 90 degree turns.
- C. Joints: Polyvinyl Chloride (PVC) integral-bell gasketed joints conforming to ASTM D3212. Rubber gaskets shall be factory installed and conform to ASTM F477.
- D. Pipe Anchor:
 - 1) Clamp:
 - a. 2" width Type 316 stainless steel pipe clamp sized to suite pipe outside diameter as manufactured by Anvil or B-Line.
 - b. 3/4" Type 316 stainless steel bolts and nuts for 8" diameter pipe.
 - c. 7/8" Type 316 stainless steel bolts and nuts for 10" and 12" diameter pipes.
 - 2) Strap Plates: 2" x 3/16" Type 316 stainless steel strap plate.
 - 3) Anchor Bolt: 1/2" Type 316 stainless steel bolts.

3. EXECUTION

- A. Inside Drop Piping:
 - 1) Install drop piping with tee fitting turned down.
 - 2) Install clamp(s) along drop piping per manufacturer's recommendations and standards spaced a maximum of 2' apart.
 - 3) Strap Plate:
 - a. Field bend as required to fit installation.
 - b. Drill 5/8" minimum diameter holes, unless otherwise approved by the Engineer, into the inside wall of the manhole for a minimum of 2.5" depth for strap plate bolt locations. Holes shall be perpendicular to the inside wall of the manhole.
 - c. Fasten strap plates to clamps.
 - d. Anchor strap plates to inside wall of manhole with anchor bolts centered in the drilled holes and annular space between bolt and manhole wall being filled with epoxy grout.

SERVICE CONNECTION TO EXISTING SEWER MAIN (DETAIL D-6)

1. GENERAL

- A. The following notes are in addition to those that apply found listed under the Sanitary Sewer Manhole standards.
- B. Service connections to existing sewer main shall be approved by the District Engineer prior to construction.
- C. Service connections are to be performed during the District's regular working hours (Mon. – Fri., 8 am to 5:00 pm) and not on the weekends without prior written permission from the District.
- D. Service connections on sewer mains shall be a minimum of 4" and a maximum of 6" in diameter. Service connections larger than 6" in diameter are considered sewer lines and require a manhole connection. See Sanitary Sewer Manhole standards.
- E. Service connections on existing reinforced concrete sewer mains of diameters 15" or less require a manhole connection. See Sanitary Sewer Manhole standards.

2. PRODUCTS

- A. Connection Fitting: Three piece service connection consisting of a Polyvinyl Chloride (PVC) hub, rubber sleeve and Type 316 stainless steel band as manufactured by Inserta Tee™.

3. EXECUTION

- A. Excavation: Existing material around existing pipe shall be removed to a level required to core drill hole for new service connection. Material removal shall not exceed going below the bottom of the existing pipe. The material even with and below the bottom of the existing pipe shall be left undisturbed.
- B. Service connection:
 - 1) District Inspector shall witness all core drilling of existing pipes.
 - 2) Contractor shall core drill hole perpendicularly through existing pipe wall as required with appropriate size coring machine for placement of new service connection to connection fitting in pipe wall at an elevation between springline and 45 degrees above springline of existing pipe.
 - 3) Core shall be removed and shown to District Inspector prior to installation of connection fitting.
 - 4) Install connection fitting in core drilled wall per manufacturer's recommendations and standards and provide a watertight seal.
 - 5) Connect new service to connection fitting per manufacturer's recommendations and standards.
 - 6) Coordinate with District Inspector for inspection and approval of connection prior to backfilling.
- C. Pipe Zone Material:
 - 1) Place and compact pipe zone material a minimum of 12" above and 8" each side of existing pipe where pipe was uncovered for service connection.
 - 2) Place and compact pipe zone material a minimum of 6" around and along service connection.

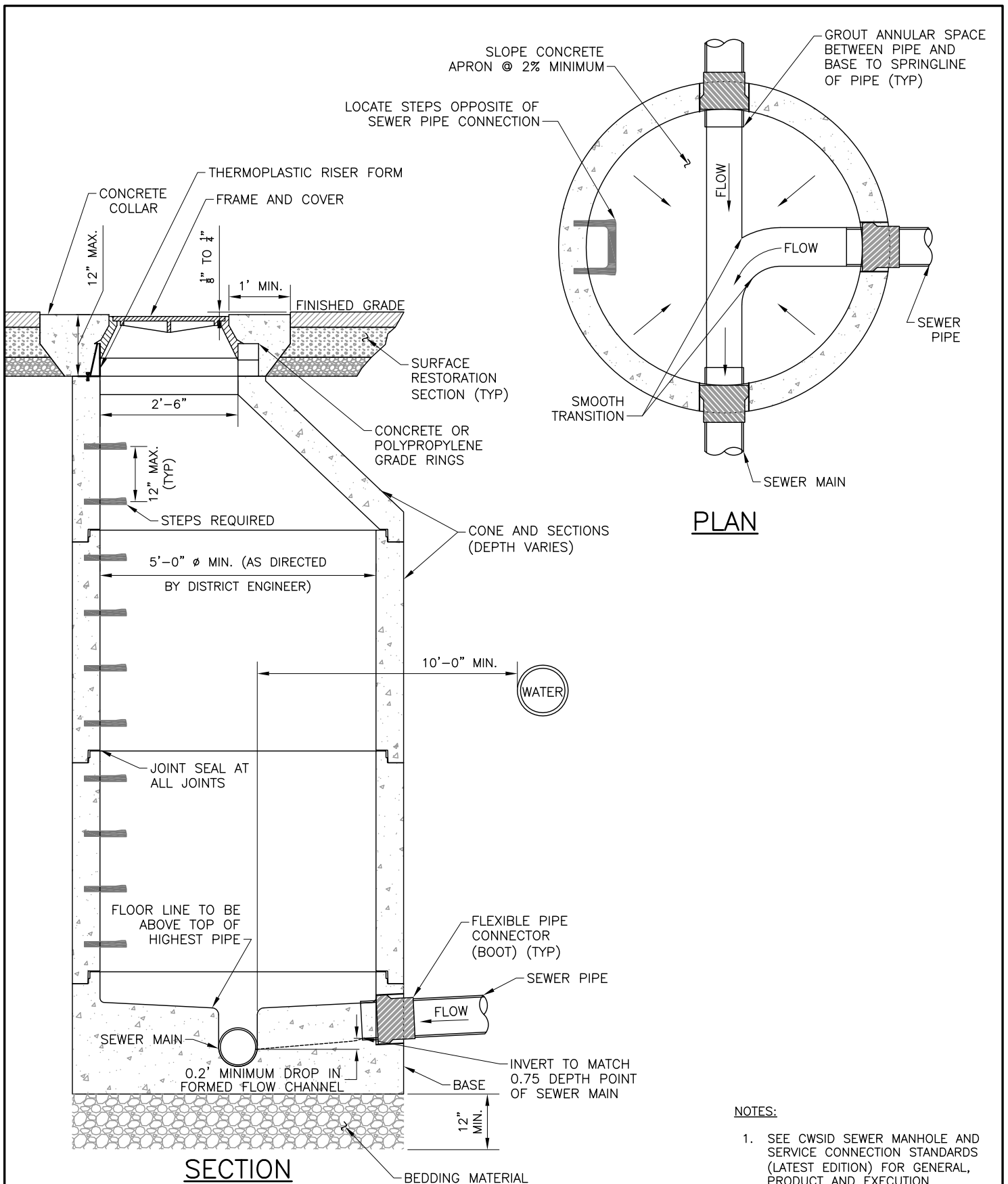

NOTES:

1. SEE CWSID SEWER MANHOLE AND SERVICE CONNECTION STANDARDS (LATEST EDITION) FOR GENERAL, PRODUCT AND EXECUTION INFORMATION.



5					
4					
3					
2					
1					
NO	DATE	REVISION	BY	CK	APP

**CENTRAL WEBER SEWER
IMPROVEMENT DISTRICT
STANDARD MANHOLE**

NO SCALE

DRAWN:	DESIGNED:	CHECKED:	APPROVED:
DATE: MAR '18	FILE NAME:	DRAWING NAME: D-1	

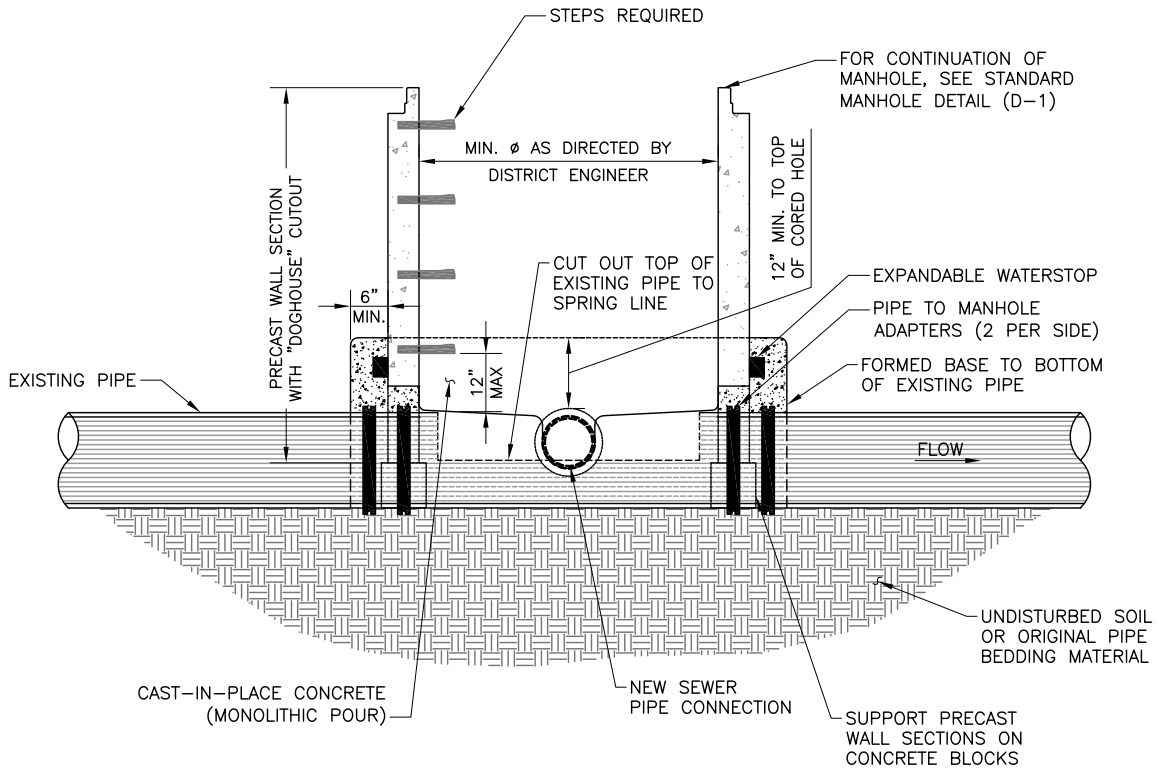

SECTION AA

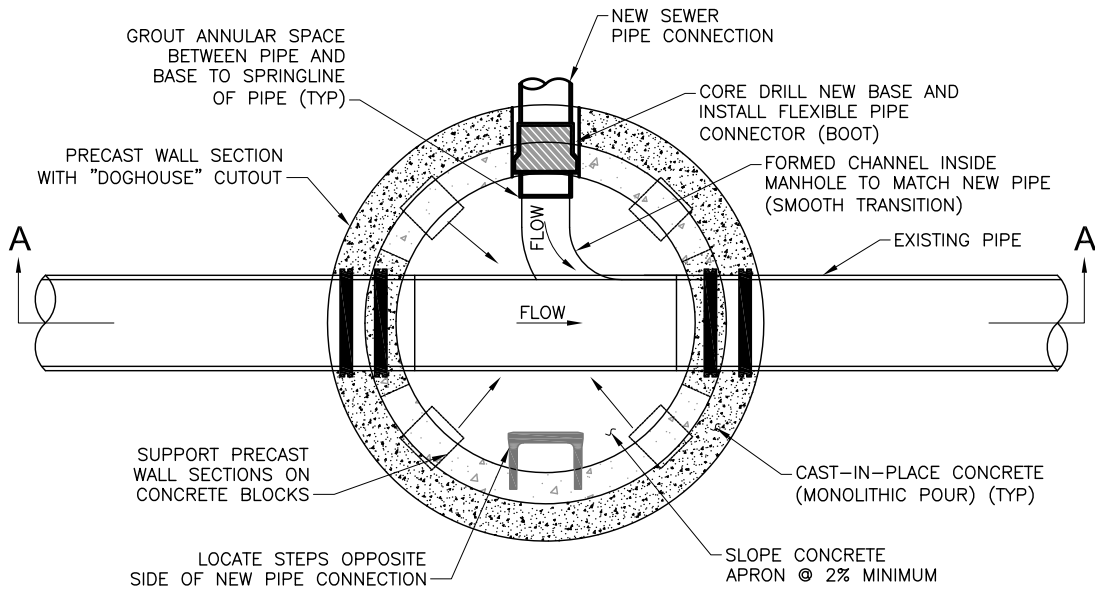

PLAN

NOTES:

1. SEE CWSID SEWER MANHOLE AND SERVICE CONNECTION STANDARDS (LATEST EDITION) FOR GENERAL, PRODUCT AND EXECUTION INFORMATION.



5					
4					
3					
2					
1					
NO	DATE	REVISION	BY	CHK	APP

**CENTRAL WEBER SEWER
IMPROVEMENT DISTRICT**

**CAST-IN-PLACE
MANHOLE BASE**

NO SCALE

DRAWN: DESIGNED: CHECKED: APPROVED:

DATE: MAR '18 FILE NAME: DRAWING NAME: D-2

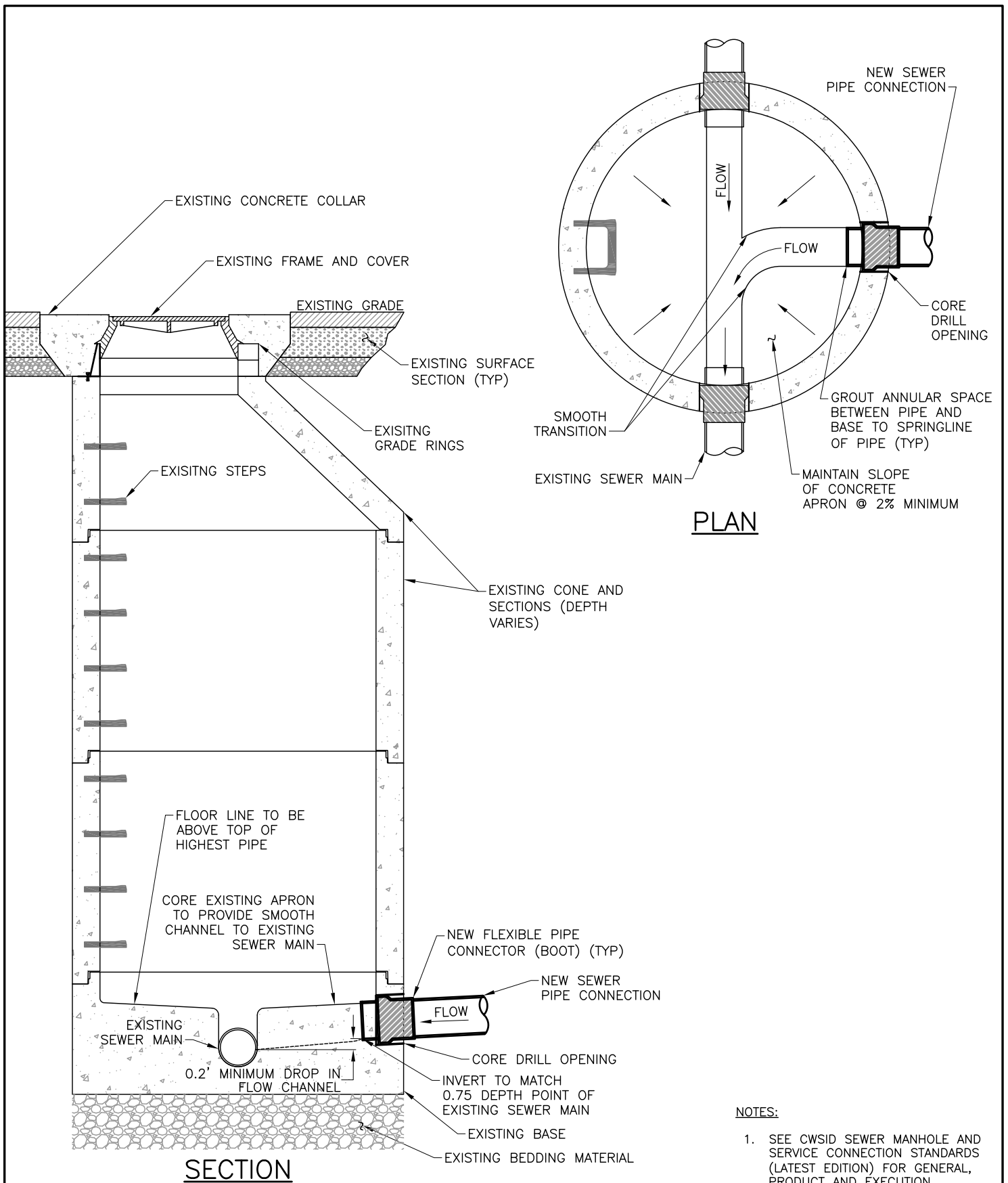

- NOTES:**
1. SEE CWSID SEWER MANHOLE AND SERVICE CONNECTION STANDARDS (LATEST EDITION) FOR GENERAL, PRODUCT AND EXECUTION INFORMATION.



5					
4					
3					
2					
1					
NO	DATE	REVISION	BY	CK	APP

**CENTRAL WEBER SEWER
IMPROVEMENT DISTRICT**
CONNECTION TO
EXISTING MANHOLE

NO SCALE			
DRAWN:	DESIGNED:	CHECKED:	APPROVED:
DATE: MAR '18	FILE NAME:	DRAWING NAME: D-3	

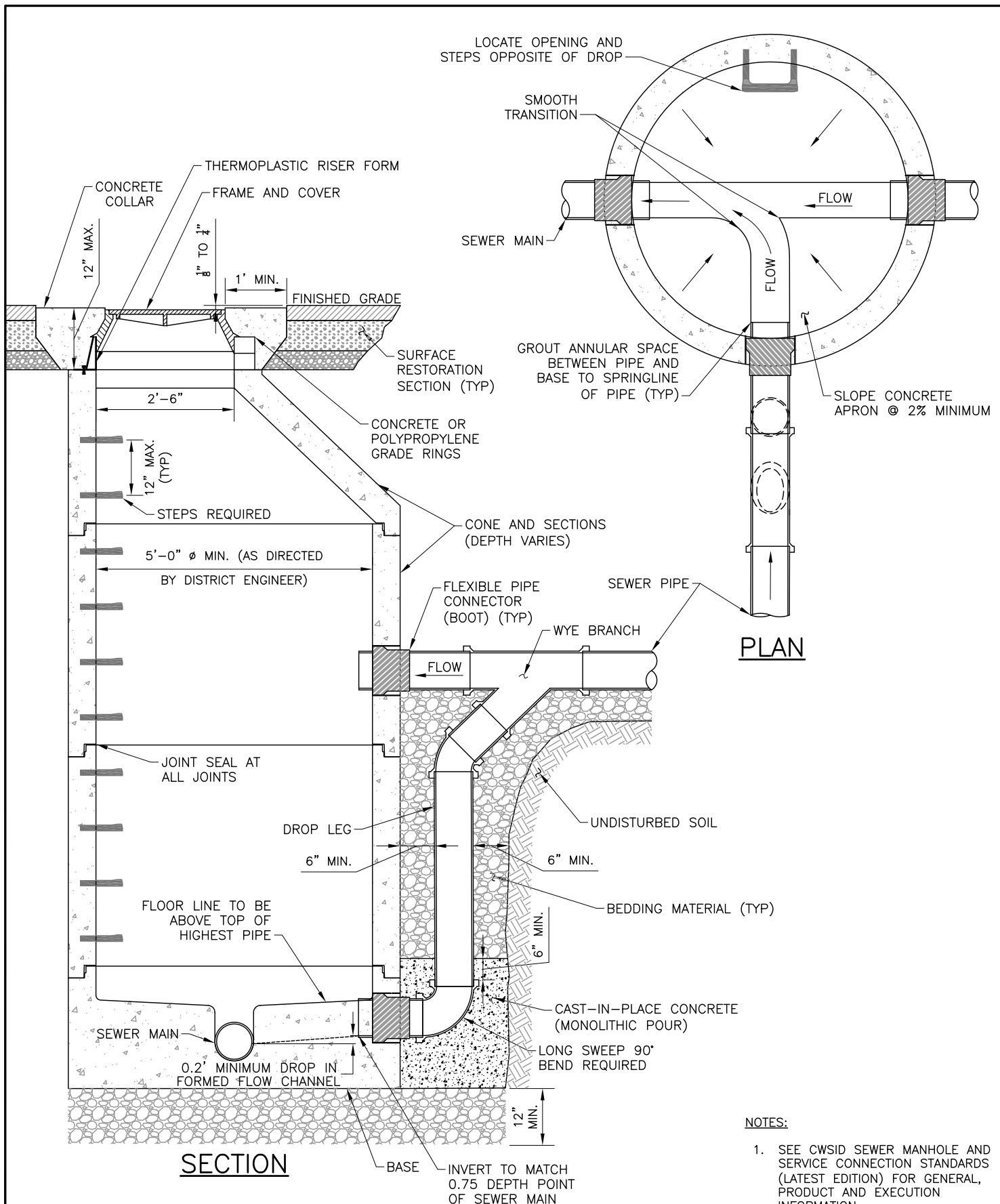

NOTES:

1. SEE CWSID SEWER MANHOLE AND SERVICE CONNECTION STANDARDS (LATEST EDITION) FOR GENERAL, PRODUCT AND EXECUTION INFORMATION.



5					
4					
3					
2					
1					
NO	DATE	REVISION	BY	CK	APP

CENTRAL WEBER SEWER IMPROVEMENT DISTRICT

OUTSIDE DROP MANHOLE

NO SCALE

DRAWN:	DESIGNED:	CHECKED:	APPROVED:
DATE: MAR '18	FILE NAME:	DRAWING NAME: D-4	

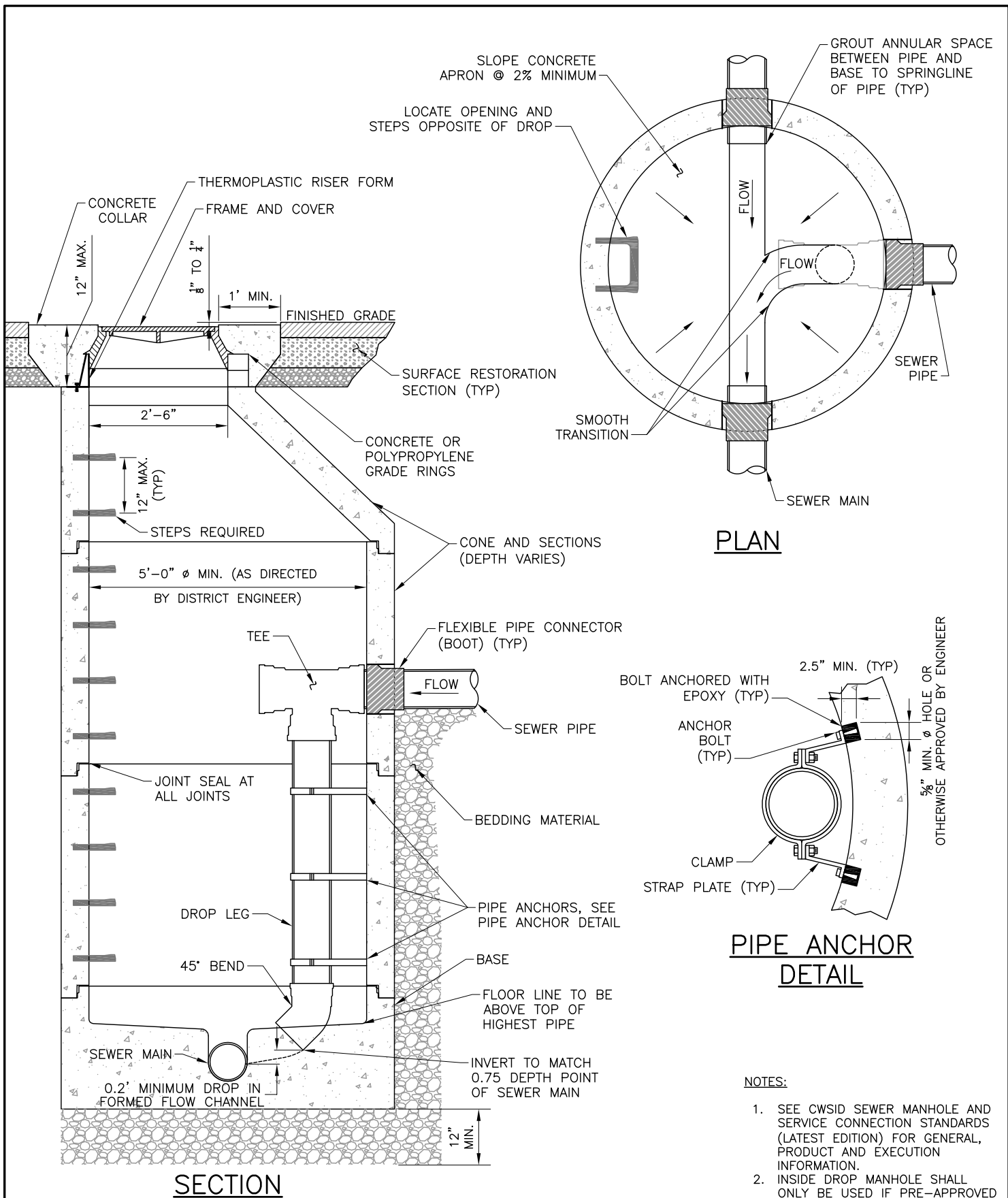

5					
4					
3					
2					
1					
NO	DATE	REVISION	BY	CK	APP

**CENTRAL WEBER SEWER
IMPROVEMENT DISTRICT
INSIDE DROP MANHOLE
(PRE-APPROVED USE ONLY)**

NO SCALE

DRAWN:	DESIGNED:	CHECKED:	APPROVED:
DATE: MAR '18	FILE NAME:	DRAWING NAME: D-5	

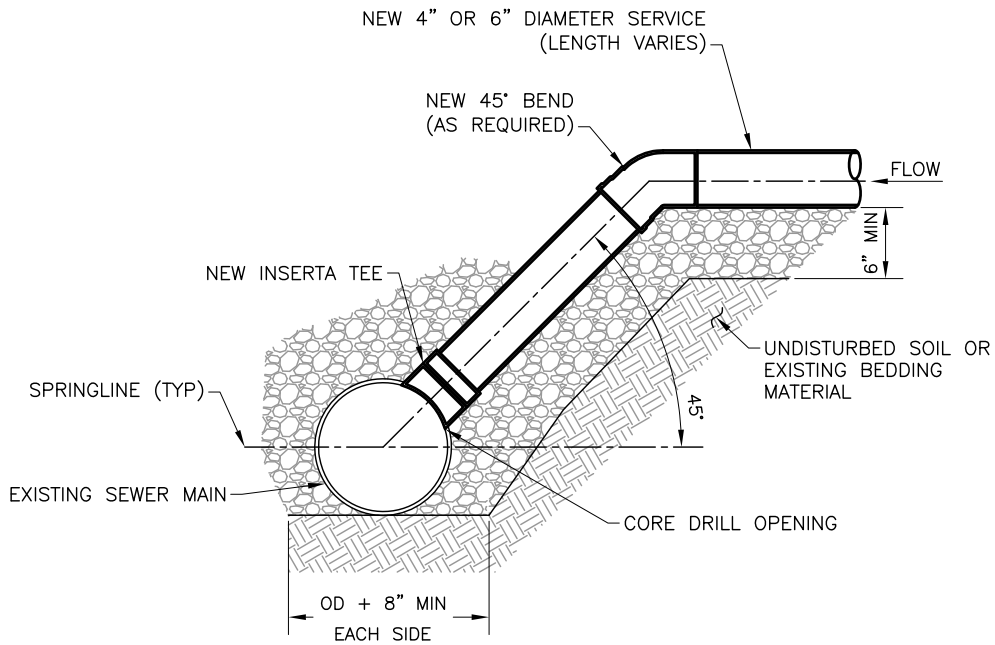

SECTION AA

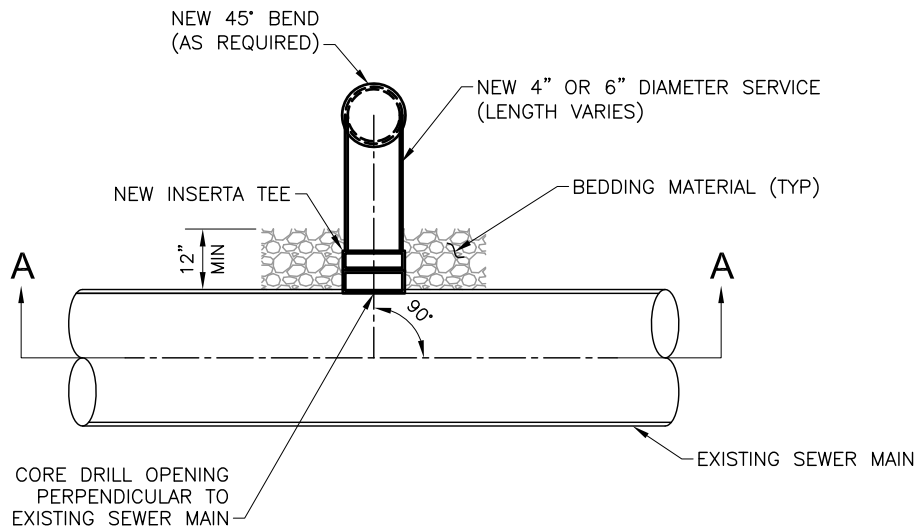

PLAN

NOTES:

1. SEE CWSID SEWER MANHOLE AND SERVICE CONNECTION STANDARDS (LATEST EDITION) FOR GENERAL, PRODUCT AND EXECUTION INFORMATION.



5					
4					
3					
2					
1					
NO	DATE	REVISION	BY	CK	APP

**CENTRAL WEBER SEWER
IMPROVEMENT DISTRICT**
SERVICE CONNECTION TO
EXISTING SEWER MAIN LINE

NO SCALE

DRAWN:	DESIGNED:	CHECKED:	APPROVED:
DATE: MAR '18	FILE NAME:	DRAWING NAME: D-6	