

REVISIONS	DESCRIPTION

Sky Ranch  
 PART OF THE NE 1/4 OF SECTION 28, T.4N., R. 1W., S.L.B. & M., U.S. SURVEY  
 WEBER COUNTY, UTAH  
**Preliminary Design**

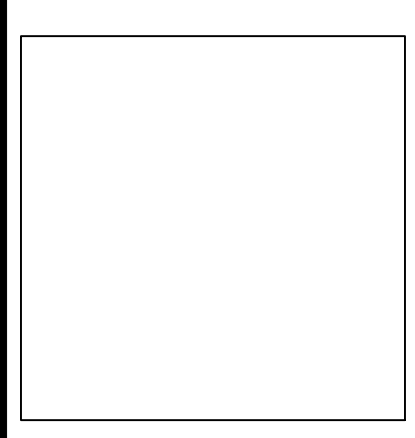

**Project Info.**

Engineer:	N. REEVE
Drafter:	E. ROCHE
Begin Date:	6-3-21
Name:	SKY RANCH
Number:	7562-02



**BOUNDARY DESCRIPTION**

PART OF THE SOUTHWEST AND SOUTHEAST QUARTERS OF SECTION 6 AND THE NORTHWEST AND NORTHEAST QUARTERS OF SECTION 7, TOWNSHIP 6 NORTH, RANGE 2 EAST, SALT LAKE BASE AND MERIDIAN, U.S. SURVEY, DESCRIBED AS FOLLOWS:

BEGINNING AT A POINT, SAID POINT BEING SOUTH 2134.52 FEET AND EAST 1282.85 FEET FROM THE WEST QUARTER CORNER OF SAID SECTION 6; THENCE S89°52'13"E 812.55 FEET; THENCE N00°07'47"E 839.91 FEET; THENCE N88°42'58"E 553.47 FEET; THENCE S02°15'27"E 1089.13 FEET; THENCE S03°42'03"E 240.34 FEET; THENCE S02°31'49"E 1142.83 FEET; THENCE S37°33'21"W 66.30 FEET; THENCE S43°11'14"W 39.66 FEET; THENCE S43°11'14"W 77.64 FEET; THENCE S42°43'44"W 23.43 FEET; THENCE S42°43'44"W 92.49 FEET; THENCE S43°33'18"W 140.66 FEET; THENCE S06°22'13"W 31.83 FEET; THENCE S42°42'50"W 127.07 FEET; THENCE S75°36'59"W 81.86 FEET; THENCE S74°58'18"W 241.01 FEET; THENCE S73°15'01"W 330.39 FEET; THENCE S71°58'08"W 73.62 FEET; THENCE N01°49'40"E 153.17 FEET; THENCE N71°13'04"E 121.64 FEET; THENCE N09°06'18"W 457.19 FEET; THENCE S89°08'01"W 420.92 FEET; THENCE N00°40'06"W 1633.16 FEET TO THE POINT OF BEGINNING.

CONTAINING 74.116 ACRES MORE OR LESS.

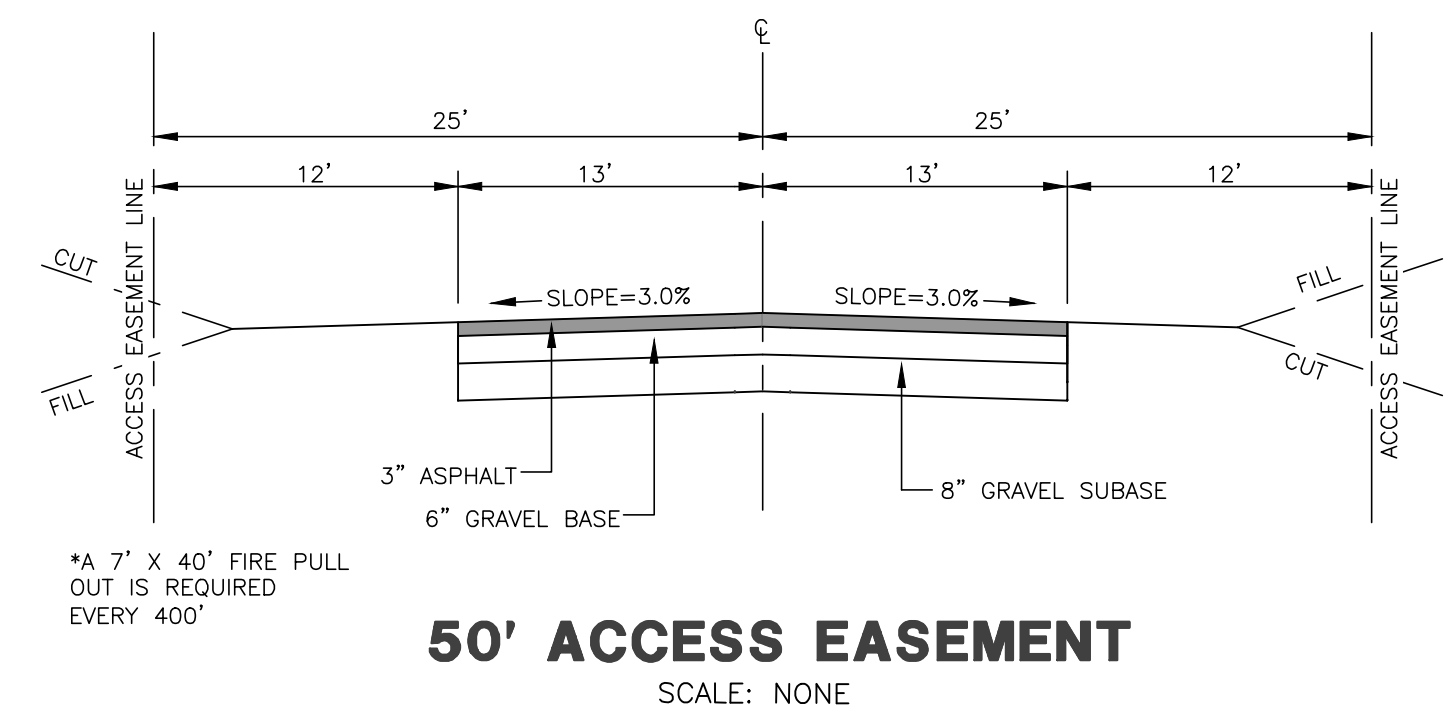

**LINE TABLE**

LINE	BEARING	DISTANCE
L1	S37°33'21"W	66.30'
L2	S43°11'14"W	39.66'
L3	S43°11'14"W	77.64'
L4	S42°43'44"W	23.43'
L5	S42°43'44"W	92.49'
L6	S43°33'18"W	140.66'
L7	S06°22'13"W	31.83'
L8	S42°42'50"W	127.07'
L9	S75°36'59"W	81.86'
L10	S74°58'18"W	241.01'
L11	S73°15'01"W	330.39'
L12	S71°58'08"W	73.62'
L13	N89°19'54"E	259.51'
L14	S41°51'13"W	134.98'
L15	S41°51'13"W	326.47'
L16	S75°58'56"W	66.14'
L17	S75°58'56"W	143.06'
L18	S72°32'50"W	309.10'

**CURVE TABLE**

#	RADIUS	ARC LENGTH	CHORD LENGTH	TANGENT	CHORD BEARING	DELTA ANGLE
C1	150.00'	235.25'	211.87'	149.63'	N44°24'07"E	89°51'34"
C2	675.00'	555.03'	539.53'	294.29'	S60°39'58"W	47°06'45"
C3	700.00'	470.01'	461.23'	244.25'	N58°55'28"E	38°28'15"
C4	680.00'	131.68'	131.47'	66.05'	S36°18'22"W	11°05'42"
C5	55.00'	32.76'	32.28'	16.88'	S58°55'06"W	34°07'40"
C6	114.50'	27.32'	27.26'	13.73'	N65°42'46"E	13°40'17"

**LEGEND**

- = SECTION CORNER
- = BOUNDARY LINE
- = LOT LINE
- = ADJOINING PROPERTY
- = EASEMENTS
- = SECTION TIE LINE
- = EXISTING FENCELINE
- = EXISTING SECONDARY WATER LINE
- = PROPOSED SECONDARY WATER LINE
- = PUBLIC UTILITY EASMENT
- = EXISTING PAVEMENT
- = PROPOSED PAVEMENT
- = EXISTING WETLANDS
- = LANDSCAPE EASEMENT FOR THE BENEFIT OF THE HOA

**Sky Ranch**  
 Weber County, Utah

**Developer:**  
 CW Land  
 1222 W. Legacy Crossing Blvd.  
 STE. 6  
 Centerville UT. 84014  
 (801) 721-9079

Revised: 07-01-2021