



VICINITY MAP

SCALE: NONE

BOUNDARY DESCRIPTION

PART OF THE NORTHWEST QUARTER OF SECTION 24, TOWNSHIP 6 NORTH, RANGE 1 EAST, SALT LAKE BASE & MERIDIAN, U.S. SURVEY. MORE PARTICULARLY DESCRIBED AS FOLLOWS:

BEGINNING AT A POINT ON THE SOUTHERLY RIGHT-OF-WAY OF STATE HIGHWAY 39, SAID POINT BEING S89°36'46"E 477.61 FEET AND S00°23'14"W 2.34 FEET FROM THE FOUND MONUMENT AT THE NORTHWEST CORNER OF SAID SECTION 24; THENCE ALONG SAID SOUTHERLY LINE, A NON-TANGENT CURVE TURNING TO THE LEFT WITH A RADIUS OF 1959.86 FEET, AN ARC LENGTH OF 254.84 FEET, A DELTA ANGLE OF 07°27'01", A CHORD BEARING OF S80°41'48"E, AND A CHORD LENGTH OF 254.66 FEET TO THE WESTERLY RIGHT-OF-WAY LINE OF OLD SNOW BASIN ROAD; THENCE ALONG SAID WESTERLY LINE THE FOLLOWING TWO (2) COURSES: (1) S04°48'23"W 313.97 FEET; (2) ALONG A TANGENT CURVE TURNING TO THE RIGHT WITH A RADIUS OF 1134.18 FEET, AN ARC LENGTH OF 117.20 FEET, A DELTA ANGLE OF 05°55'15", A CHORD BEARING OF S07°46'00"W, AND A CHORD LENGTH OF 117.15 FEET TO THE NORTH LINE OF CHALETS AT SKI LAKE PHASE 1; THENCE ALONG SAID NORTH LINE THE FOLLOWING TWO (2) COURSES: (1) N77°56'06"W 194.61 FEET; (2) N77°56'13"W 271.39 FEET TO THE EAST LINE OF CHALETS AT SKI LAKE PHASE 3; THENCE ALONG SAID EAST LINE THE FOLLOWING THREE (3) COURSES: (1) N12°03'47"E 156.02 FEET; (2) S77°56'13"E 158.81 FEET; (3) N13°01'42"E 260.03 FEET TO THE SOUTHERLY RIGHT-OF-WAY LINE OF STATE HIGHWAY 39 AND TO THE POINT OF BEGINNING.

CONTAINING 144,146 SQUARE FEET OR 3.309 ACRES MORE OR LESS.

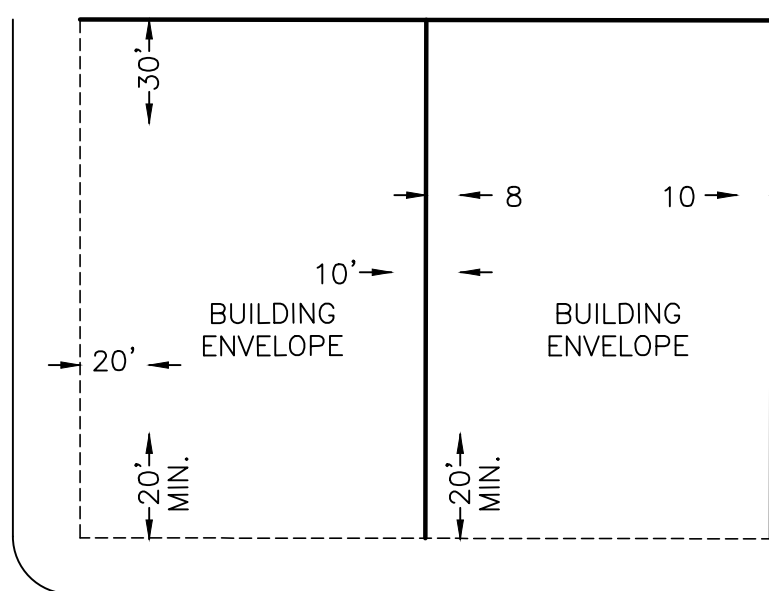

PROPOSED SETBACK DETAIL

SCALE: NONE

LEGEND

- = SECTION CORNER
- = BOUNDARY LINE
- = LOT LINE
- = ADJOINING PROPERTY
- = EASEMENTS
- = SECTION TIE LINE
- = EXISTING FENCELINE
- = PROPOSED SANITARY SEWER LINE
- = EXISTING SANITARY SEWER LINE
- = PROPOSED CULINARY WATER LINE
- = EXISTING CULINARY WATER LINE
- = EXISTING STORM DRAIN
- = SWALE
- = EXISTING POWER LINE
- = EXISTING POWER POLE
- = PROPOSED FIRE HYDRANT
- = PROPOSED SANITARY SEWER/STORM DRAIN MANHOLE
- = EXISTING SANITARY SEWER/STORM DRAIN MANHOLE
- = PLUG W/ 2" BLOW-OFF
- = PROPOSED STORM DRAIN MANHOLE
- = PROPOSED SINGLE GRATE CATCH BASIN WITH BICYCLE-SAFE GRATE
- = EXISTING CATCH BASIN
- = PUBLIC UTILITY EASEMENT
- = EXISTING PAVEMENT
- = PROPOSED PAVEMENT
- = PROPOSED CONCRETE
- = BUILDING ENVELOPE

NOTES

- CONTOURS ARE SHOWN IN ONE FOOT INTERVALS.
- PROPERTY IS IN ZONE X PER FEMA FLOOD PANEL 49057C0475F EFFECTIVE 6-2-2015
- PARCEL 'A' WILL BE OWNED AND MAINTAINED BY THE HOA.

PARKING INFO.

TOTAL UNITS.....13
TOTAL PARKING STALLS PROPOSED.....100

CURVE TABLE

#	RADIUS	ARC LENGTH	CHORD LENGTH	TANGENT	CHORD BEARING	DELTA ANGLE
C1	1959.86'	254.84'	254.66'	127.60'	S80°41'48"E	7°27'01"
C2	1134.18'	117.20'	117.15'	58.65'	S07°46'00"W	5°55'15"
C3	1959.86'	82.28'	82.28'	41.15'	S78°10'28"E	2°24'20"
C4	1959.86'	85.10'	85.09'	42.56'	S80°37'16"E	2°29'16"
C5	1959.86'	87.46'	87.45'	43.74'	S83°08'36"E	2°33'25"

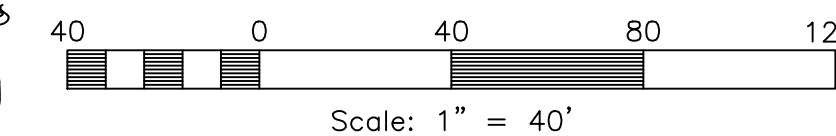

NORTHWEST CORNER OF SECTION 24 TOWNSHIP 6 NORTH, RANGE 1 EAST, SALT LAKE BASE & MERIDIAN, U.S. SURVEY, FOUND WEBER COUNTY SURVEY BRASS CAP MONUMENT MARKED "2006" IN CONCRETE 15" BELOW GROUND

NORTH QUARTER CORNER OF SECTION 24 TOWNSHIP 6 NORTH, RANGE 1 EAST, SALT LAKE BASE & MERIDIAN, U.S. SURVEY, FOUND WEBER COUNTY SURVEY BRASS CAP MONUMENT MARKED "2020" IN RING AND LID 8" BELOW GROUND



Storm Runoff Calculations
THE BASIN
7562-03 5/13/2021

The following runoff calculations are based on the Rainfall - Intensity - Duration Frequency Curve for the Huntsville, UT area taken from the NOAA Atlas 14 database. Calculations have been completed for the 100-yr 24-hr storm event. Storm water runoff has been calculated for a fully developed site and limited to a release rate of 0.2 cfs/acre.

The calculations are as follows:

Drainage Area:	Total Area = 3.31 acre or 144,146 ft ²
Runoff Coefficients:	20% Paved Area: 28,473 C = 0.9
	26% Roof: 36,979 C = 0.9
	55% Landscaped Area: 78,694 C = 0.2
Weighted Runoff Coefficient:	C = 0.52

LID Retention

80 th Percentile Rainfall Event	0.45 in
Is the site Feasible for LID?	Yes
Site Imperviousness	0.45
NRCS Soil Group	C/D
Rv Equation	0.83*1.122
R _v	0.34
V _{req}	1850 c.f.

Volume of Run-off for 100-year Storm Event:

time (min)	time (sec)	Q (cfs)	Vol. in (cf)	Vol. out (cf)	Difference (cf)	
0	0.00	0.00	0	0	0	
5	300	7.48	12.92	3877	199	3679
10	600	5.68	9.81	5889	397	5492
15	900	4.7	8.12	7309	596	6713
30	1800	3.16	5.46	9828	1191	8637
60	3600	1.96	3.39	12192	2383	9810
120	7200	1.13	1.95	14058	4765	9293
180	10800	0.777	1.34	14500	7148	7352
360	21600	0.437	0.76	16310	14295	2015
720	43200	0.275	0.48	20528	28591	-8063
1440	86400	0.158	0.27	23588	57182	-33594

Orifice Sizing

Given: Q = 0.66 cfs
2g = 64.4 ft/s²
H = 3.00 ft (Estimate)
Cd = 0.62 for circular openings
R = SQRT(Q/(pi*(0.7*(64.4H)^0.5))
R = 0.16 feet
D = 1.88 inches
A = 3.75 inches
A = 11.06 inches * 2 = 0.0768 ft * 2

SUMMARY:
The required 100-yr storage volume is **9,810** cubic feet
The required LID Retention volume is **1,850** cubic feet
Orifice size is **4** inches

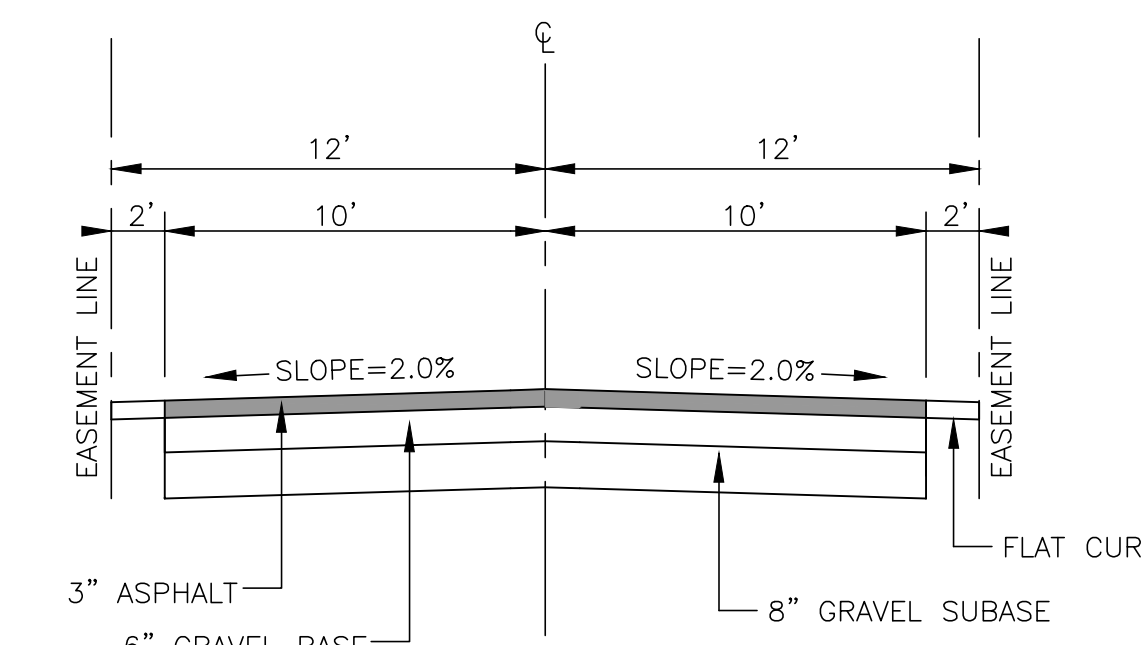

24' PRIVATE ROADWAY

SCALE: NONE

LINE TABLE

LINE	BEARING	DISTANCE
L1	S77°56'13"E	75.81'
L2	S77°56'13"E	158.81'
L3	S77°56'13"E	77.27'
L4	S77°56'13"E	133.93'
L5	S77°56'13"E	77.27'
L6	S77°56'13"E	75.81'
L7	S77°56'13"E	164.13'
L8	S77°56'13"E	75.81'
L9	S77°56'13"E	74.91'
L10	N12°03'47"E	119.50'
L11	N12°03'47"E	119.50'
L12	N12°03'47"E	119.50'
L13	N12°03'47"E	119.50'
L14	N12°03'47"E	119.50'
L15	N12°03'47"E	36.52'
L16	N12°03'47"E	83.00'
L17	N12°03'47"E	81.00'
L18	S77°56'13"E	131.78'
L19	S77°56'13"E	143.25'
L20	N12°03'47"E	132.85'
L21	N12°03'47"E	136.84'
L22	S77°56'13"E	133.15'
L23	S77°56'13"E	153.57'

The Basin

Weber County, Utah

Reeve & Associates, Inc.
5160 SOUTH 1500 WEST, RIVERDALE, UTAH 84405
TEL: (801) 621-3100 FAX: (801) 621-2666 www.reeve-associates.com
TRAFFIC ENGINEERS • CIVIL ENGINEERS • LAND SURVEYORS • ARCHITECTS

REVISIONS	DESCRIPTION	DATE

PART OF THE NW 1/4 OF SECTION 24, T.6N., R.1E., S.L.B. & M., U.S. SURVEY
WEBER COUNTY, UTAH

Preliminary Plan

Project Info.
Engineer: N. Reeve
Designer: C. Cave
Begin Date: 5-6-21
Name: THE BASIN
Number: 7562-03