

PROPRIETY INFORMATION:  
THE INFORMATION CONTAINED IN THIS SET OF DRAWINGS IS PROPRIETARY BY NATURE. ANY USE OR DISCLOSURE OTHER THAN THAT WHICH RELATES TO T-MOBILE SERVICES IS STRICTLY PROHIBITED.

DISCLOSURE:  
NO SITE WALK WAS CONDUCTED FOR THESE DRAWINGS. DATA WAS PROVIDED BY T-MOBILE AND/OR OTHERS. CONTRACTOR TO VERIFY MATERIALS AND DESIGN PRIOR TO INSTALL.



# SL01743A PROM RMP GLASMANN WAY

4700 SOUTH GLASMANN WAY  
OGDEN, UT 84403

PROJECT: ANCHOR

## SCOPE OF WORK

T-MOBILE IS PROPOSING TO ADD THREE(3) ANTENNA, AND ADD THREE (3) RRU's. FINAL TOWER CONFIGURATION: TWELVE (12) ANTENNAS, THREE (3) TMAs, SIX (6) RRU's, TWELVE (12) COAX LINES AND THREE (3) HCS.

T-MOBILE IS PROPOSING TO ADD 6160 EQUIPMENT CABINET, ONE (1) BB6648, THREE (3) BB6630, ONE (1) PSU 48 13 VOLTAGE BOOSTER AND B160 BATTERY CABINET TO GROUND EQUIPMENT.

## MODERNIZATION EQUIPMENT LIST

SECTOR	TYPE	MODEL	QUANTITY
ALPHA	ANTENNA	CMA-BDHH/6521/E0-6/TB05 (QUAD)	1
ALPHA	ANTENNA	APXVAARR24 43-U-NA20 (OCTO)	1
ALPHA	ANTENNA	AIR32 KRD901146-1 B66A/B2A (OCTA)	1
ALPHA	ANTENNA	AIR6449 B41 (ACTIVE ANTENNA - MASSIVE MIMO)	1
ALPHA	TMA	GENERIC TWIN STYLE 1A - PCS	1
ALPHA	RRU	4449 B71+B85	1
ALPHA	RRU	4415 B25	1
ALPHA	COAX	7/8" - 85'	4
BETA	ANTENNA	CMA-BDHH/6521/E0-6/TB05 (QUAD)	1
BETA	ANTENNA	APXVAARR24 43-U-NA20 (OCTO)	1
BETA	ANTENNA	AIR32 KRD901146-1 B66A/B2A (OCTA)	1
BETA	ANTENNA	AIR6449 B41 (ACTIVE ANTENNA - MASSIVE MIMO)	1
BETA	TMA	GENERIC TWIN STYLE 1A - PCS	1
BETA	RRU	4449 B71+B85	1
BETA	RRU	4415 B25	1
BETA	COAX	7/8" - 85'	4
GAMMA	ANTENNA	CMA-BDHH/6521/E0-6/TB05 (QUAD)	1
GAMMA	ANTENNA	APXVAARR24 43-U-NA20 (OCTO)	1
GAMMA	ANTENNA	AIR32 KRD901146-1 B66A/B2A (OCTA)	1
GAMMA	ANTENNA	AIR6449 B41 (ACTIVE ANTENNA - MASSIVE MIMO)	1
GAMMA	TMA	GENERIC TWIN STYLE 1A - PCS	1
GAMMA	RRU	4449 B71+B85	1
GAMMA	RRU	4415 B25	1
GAMMA	COAX	7/8" - 85'	4
SITE	HCS	6x12 HCS 6AWG 30m	3
SITE	BASEBAND	BB 6648	1
SITE	BASEBAND	BB 6630	3
SITE	VOLTAGE BOOSTER	PSU 48 13	1

## GENERAL LOCATION MAP

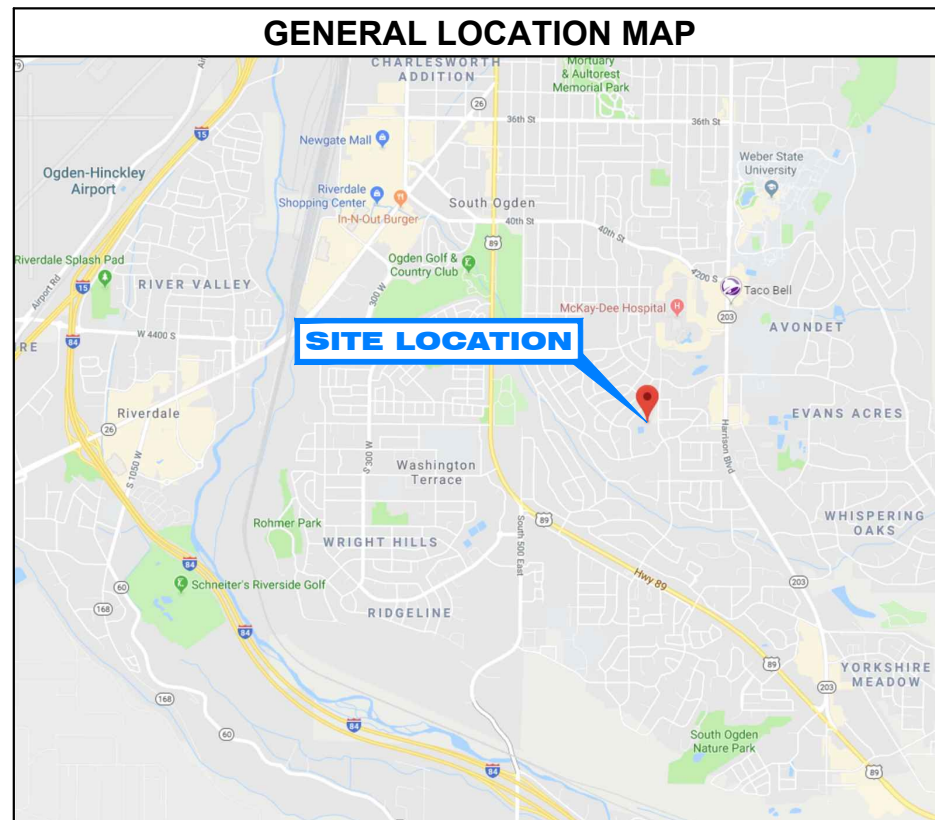

## VICINITY MAP



## APPROVALS

APPROVED BY	PRINT NAME	INITIALS	DATE
PROJECT MANAGER			
RF ENGINEER			
OPS MANAGER			
CONSTRUCTION			
LANDLORD			

## CONTACT INFORMATION

<p><b>STRUCTURE OWNER</b> PACIFICORP 825 N.E. MULTNOMAH ST. SUITE 1700 PORTLAND, OR 97232</p>	<p><b>SITE ACQUISITION FIRM</b> RAGE DEVELOPMENT LLC 2181 HUGO AVENUE SALT LAKE CITY, UT 84117</p>
<p><b>NETWORK SYSTEMS OWNER</b> T-MOBILE 121 WEST ELECTION RD. STE. 330 DRAPER, UT 84020</p>	<p><b>A/E FIRM</b> SMITH HYATT ARCHITECTS 845 SOUTH MAIN STREET BOUNTIFUL, UT 84010</p>



845 SOUTH MAIN, BOUNTIFUL, UTAH 84010  
801-298-5777 FAX 801-298-1677

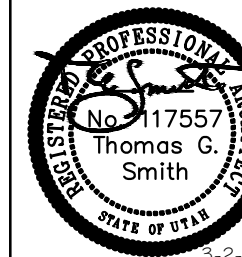

DATE: 5.29.2020  
DRAWN BY: JRC  
CHECKED BY: BRITTON KNAPHUS

## REVISIONS

DATE	DESCRIPTION	INT.
5.29.20	CD's (Prelim)	JRC
6.1.20	CD's (Final)	JRC
6.9.20	CD's (Final-R1)	JRC
6.11.20	CD's (Final-R2)	JRC
3.2.21	CD's (Final-R3; ADD STRUCT. GUY WIRES)	JRC

SL01743A  
PROM RMP GLASMANN WAY  
4700 SOUTH GLASMANN WAY  
OGDEN, UT 84403

DRAWING TITLE:  
TITLE SHEET

DRAWING NO.:  
T-1

## GENERAL CONSTRUCTION NOTES

1. DRAWINGS WERE PREPARED FROM STANDARDIZED DETAILS DEVELOPED AND PROVIDED BY T-MOBILE WEST, LLC ("T-MOBILE"). STANDARDIZED DETAILS ARE TO BE CONFIRMED AND CORRELATED AT THE SITE BY THE CONTRACTOR. STANDARDIZED DETAILS THAT REQUIRE MODIFICATIONS DUE TO ACTUAL FIELD CONDITIONS AND REQUIREMENTS MUST BE SUBMITTED TO, AND APPROVED BY, T-MOBILE PRIOR TO START OF WORK.
2. DRAWINGS ARE NOT TO BE SCALED. WRITTEN DIMENSIONS TAKE PRECEDENCE. THIS SET OF DOCUMENTS IS INTENDED TO BE USED FOR DIAGRAM PURPOSES ONLY. UNLESS OTHERWISE NOTED. THE CONTRACTOR IS RESPONSIBLE FOR ALL DIMENSIONS.
3. THE GENERAL CONTRACTOR'S SCOPE OF WORK SHALL INCLUDE FURNISHING ALL MATERIALS, EQUIPMENT, LABOR, AND ANY REQUIREMENTS DEEMED NECESSARY TO COMPLETE INSTALLATION AS DESCRIBED IN THE DRAWINGS AND AS DISCUSSED ON THE SITE WALK.
4. PRIOR TO THE SUBMISSION OF BIDS, CONTRACTORS INVOLVED SHALL VISIT THE JOB SITE TO FAMILIARIZE THEMSELVES WITH ALL CONDITIONS AFFECTING THE PROPOSED PROJECT. CONTRACTORS SHALL VISIT THE CONSTRUCTION SITE WITH THE CONSTRUCTION DOCUMENTS TO VERIFY FIELD CONDITIONS AND CONFIRM THAT THE PROJECT WILL BE ACCOMPLISHED AS SHOWN. PRIOR TO PROCEEDING WITH CONSTRUCTION, ANY ERRORS, OMISSIONS, OR DISCREPANCIES SHALL BE BROUGHT TO THE ATTENTION OF T-MOBILE VERBALLY AND IN WRITING.
5. THE GENERAL CONTRACTOR SHALL RECEIVE WRITTEN AUTHORIZATION TO PROCEED WITH CONSTRUCTION PRIOR TO STARTING WORK ON ANY ITEM NOT CLEARLY DEFINED BY THE CONSTRUCTION DRAWINGS.
6. THE CONTRACTOR SHALL SUPERVISE AND DIRECT THE PROJECT DESCRIBED IN THE CONTRACT DOCUMENTS. THE CONTRACTOR SHALL BE SOLELY RESPONSIBLE FOR ALL CONSTRUCTION MEANS, METHODS, TECHNIQUES, SEQUENCES, AND PROCEDURES FOR COORDINATING ALL PORTIONS OF THE WORK UNDER THE CONTRACT.
7. THE CONTRACTOR SHALL INSTALL ALL EQUIPMENT AND MATERIALS ACCORDING TO MANUFACTURER'S/VENDOR'S SPECIFICATIONS UNLESS NOTED OTHERWISE OR WHERE LOCAL CODES OR ORDINANCES TAKE PRECEDENCE.
8. ALL WORK PERFORMED ON THE PROJECT AND MATERIALS INSTALLED SHALL BE IN STRICT ACCORDANCE WITH ALL APPLICABLE CODES, REGULATIONS, AND ORDINANCES. CONTRACTOR SHALL GIVE ALL NOTICES AND COMPLY WITH ALL LAWS, ORDINANCES, RULES, REGULATIONS AND LAWFUL ORDERS OF ANY PUBLIC AUTHORITY, MUNICIPAL AND UTILITY COMPANY SPECIFICATIONS, AND LOCAL AND STATE JURISDICTIONAL CODES BEARING ON THE PERFORMANCE OF THE WORK.
9. GENERAL CONTRACTOR SHALL PROVIDE, AT THE PROJECT SITE, A FULL SET OF CONSTRUCTION DOCUMENTS UPDATED WITH THE LATEST REVISIONS AND ADDENDA OR CLARIFICATIONS FOR USE BY ALL PERSONNEL INVOLVED WITH THE PROJECT.
10. THE STRUCTURAL COMPONENTS OF ADJACENT CONSTRUCTION OR FACILITIES ARE NOT TO BE ALTERED BY THIS CONSTRUCTION PROJECT UNLESS NOTED OTHERWISE.
11. CONTRACTOR TO SEAL ALL PENETRATIONS THROUGH FIRE-RATED AREAS WITH U.L. LISTED OR FIRE MARSHALL APPROVED MATERIALS IF APPLICABLE TO THIS FACILITY AND OR PROJECT SITE.

12. CONTRACTOR TO PROVIDE A PORTABLE FIRE EXTINGUISHER WITH A RATING OF NOT LESS THAN 2-A OR 2-A10BC WITHIN 75 FEET TRAVEL DISTANCE TO ALL PORTIONS OF PROJECT AREA DURING CONSTRUCTION.
13. CONTRACTOR SHALL MEET ALL OSHA REQUIREMENTS FOR ALL INSTALLATIONS.
14. CONTRACTOR TO VERIFY LOCATION OF ALL BURIED UTILITIES PRIOR TO EXCAVATION.
15. CONTRACTOR SHALL MAKE NECESSARY PROVISIONS TO PROTECT EXISTING IMPROVEMENTS, EASEMENTS, PAVING, CURBING, ETC. DURING CONSTRUCTION, UPON COMPLETION OF WORK, CONTRACTOR SHALL REPAIR ANY DAMAGE THAT MAY HAVE OCCURRED DUE TO CONSTRUCTION ON OR ABOUT THE PROPERTY.
16. CONTRACTOR SHALL KEEP GENERAL WORK AREA CLEAN AND HAZARD FREE DURING CONSTRUCTION AND DISPOSE OF ALL DIRT, DEBRIS, AND RUBBISH. CONTRACTOR SHALL REMOVE EQUIPMENT NOT SPECIFIED AS REMAINING ON THE PROPERTY OR PREMISES. SITE SHALL BE LEFT IN CLEAN CONDITION DAILY AND FREE FROM PAINT SPOTS, DUST, OR SMUDGES OF ANY NATURE.
17. THE ARCHITECTS/ENGINEERS HAVE MADE EVERY EFFORT TO SET FORTH IN THE CONSTRUCTION AND CONTRACT DOCUMENTS THE COMPLETE SCOPE OF WORK. CONTRACTORS BIDDING THE JOB ARE NEVERTHELESS CAUTIONED THAT MINOR OMISSIONS OR ERRORS IN THE DRAWINGS AND OR SPECIFICATIONS SHALL NOT EXCUSE SAID CONTRACTOR FROM COMPLETING THE PROJECT AND IMPROVEMENTS IN ACCORDANCE WITH THE INTENT OF THESE DOCUMENTS. THE BIDDER SHALL BEAR THE RESPONSIBILITY OF NOTIFYING (IN WRITING) T-MOBILE OF ANY CONFLICTS, ERRORS, OR OMISSIONS PRIOR TO SUBMISSION OF CONTRACTOR'S PROPOSAL. IN THE EVENT OF DISCREPANCIES THE CONTRACTOR SHALL PRICE THE MORE COSTLY OR EXTENSIVE WORK, UNLESS DIRECTED OTHERWISE.
18. THE CONTRACTOR SHALL PERFORM WORK DURING OWNER'S PREFERRED HOURS TO AVOID DISTURBING NORMAL BUSINESS.
19. THE CONTRACTOR SHALL PROVIDE T-MOBILE CORPORATION PROPER INSURANCE CERTIFICATES NAMING T-MOBILE WEST, LLC AS ADDITIONAL INSURED, AND T-MOBILE WEST, LLC PROOF OF LICENSE(S) AND PL & PD INSURANCE.

### CODE COMPLIANCE

ALL WORK AND MATERIALS SHALL BE PERFORMED AND INSTALLED IN ACCORDANCE WITH THE CURRENT CONDITIONS OF THE FOLLOWING CODES AS ADOPTED BY THE LOCAL GOVERNING AUTHORITIES. NOTHING IN THESE PLANS IS TO BE CONSTRUED TO PERMIT WORK NOT CONFORMING TO THESE CODES.

- A. UTAH UNIFORM BUILDING STANDARD ACT RULES
- B. 2018 INTERNATIONAL BUILDING CODE (IBC)
- C. 2017 NATIONAL ELECTRIC CODE (NEC)
- D. 2018 INTERNATIONAL BUILDING CODE (IBC)
- E. 2018 INTERNATIONAL FIRE CODE (IFC)
- F. 2018 INTERNATIONAL MECHANICAL CODE (IMC)
- G. LOCAL BUILDING CODE
- H. CITY OR COUNTY ORDINANCES

### IMPORTANT NOTICE

THE EXISTING CONDITIONS REPRESENTED HEREIN ARE BASED ON VISUAL OBSERVATIONS AND INFORMATION PROVIDED BY OTHERS. A/E FIRM CANNOT GUARANTEE THE CORRECTNESS NOR THE COMPLETENESS OF THE EXISTING CONDITIONS SHOWN AND ASSUMES NO RESPONSIBILITY THEREOF. THE CONTRACTOR SHALL VISIT THE SITE AND VERIFY ALL EXISTING CONDITIONS AS REQUIRED FOR PROPER COMPLETION OF THE PROJECT.

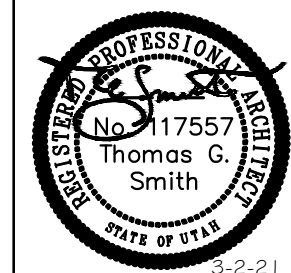

DATE: 5.29.2020

DRAWN BY: JRC

CHECKED BY: BRITTON KNAPHUS

### **REVISIONS**

DATE	DESCRIPTION	INT.
5.29.20	CD's (Prelim)	JRC
6.1.20	CD's (Final)	JRC
6.9.20	CD's (Final-R1)	JRC
6.11.20	CD's (Final-R2)	JRC
3.2.21	CD's (Final-R3: ADD STRUCT. GUY WIRES)	JRC

**SL01743A**  
**PROM RMP GLASSMANN WAY**  
 4700 SOUTH GLASSMANN WAY  
 OGDEN, UT 84403

DRAWING TITLE:  
GENERAL NOTES

DRAWING NO.:  
**N-1**

# EXISTING EQUIPMENT SITE PLAN

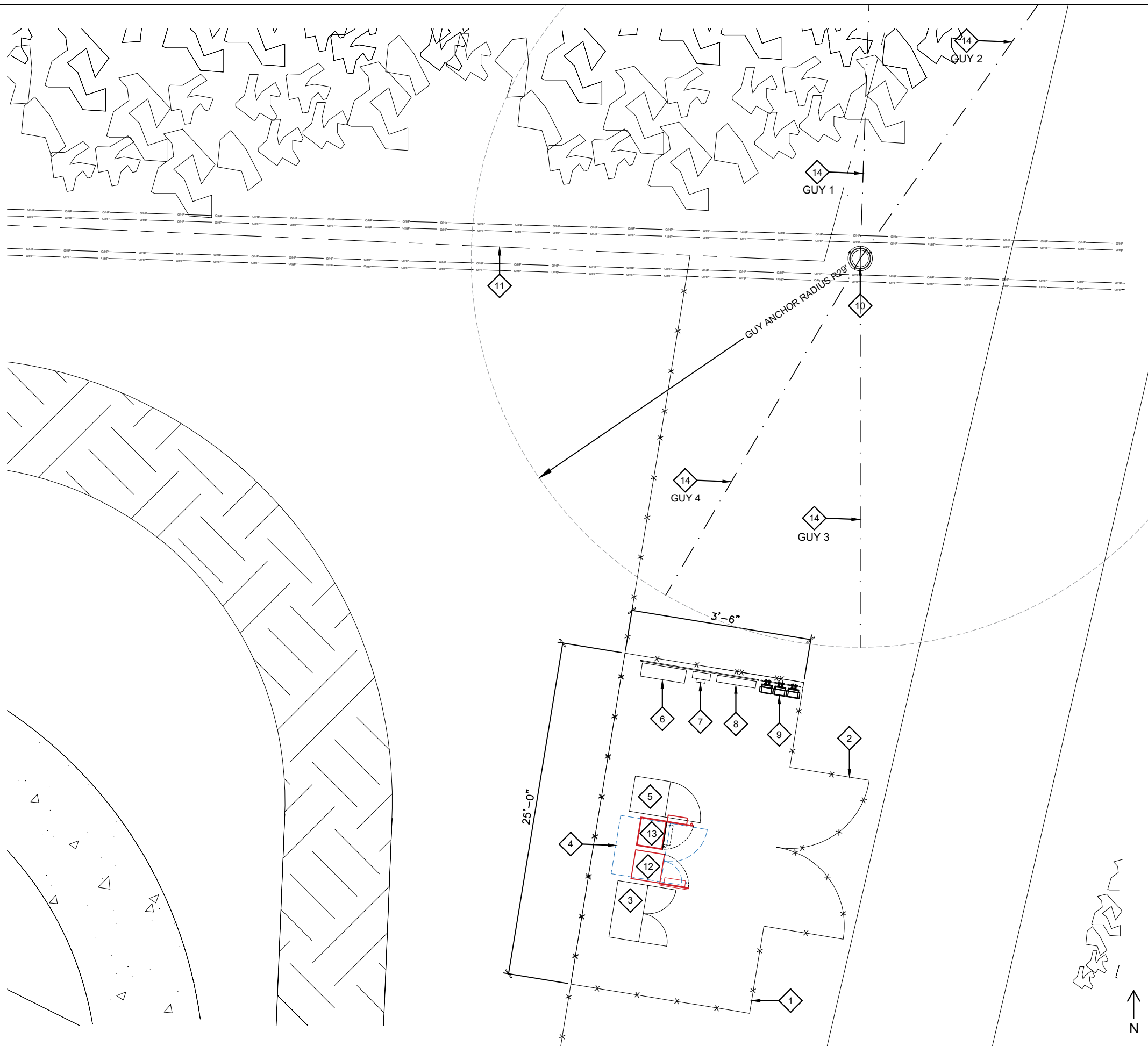

## KEY NOTES

- 1 EXISTING T-MOBILE EQUIPMENT AREA
- 2 EXISTING ACCESS GATE
- 3 EXISTING RBS 6102 CABINET
- 4 EXISTING NORTEL EQUIPMENT CABINET TO BE REPLACED BY 6160 AND B160
- 5 EXISTING COAX CABINET
- 6 EXISTING TELCO CABINET
- 7 EXISTING METER
- 8 EXISTING 3106 CABINET
- 9 EXISTING RRUs
- 10 EXISTING 60' UTILITY POLE
- 11 EXISTING PARCEL LINE, TYP
- 12 PROPOSED 6160 CABINET
- 13 PROPOSED B160 BATTERY CABINET
- 14 PROPOSED GUY WIRE PER STRUCTURAL ANALYSIS COMPLETED BY ANDERSON ENGINEERING DATED MARCH 2, 2021

## SITE NOTES

1. TMO IS PROPOSING TO ADD 6160 WITH ONE BB6648 AND THREE (3) BB 6630 UNITS AND A PSU 48 13 VOLTAGE BOOSTER TO GROUND CABINET LAYOUT.
2. TMO IS PROPOSING TO ADD B160 BATTERY CABINET.

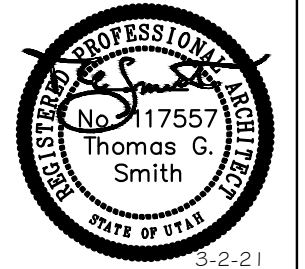

DATE: 5.29.2020

DRAWN BY: JRC

CHECKED BY: BRITTON KNAPHUS

### REVISIONS

DATE	DESCRIPTION	INT.
5.29.20	CD's (Prelim)	JRC
6.1.20	CD's (Final)	JRC
6.9.20	CD's (Final-R1)	JRC
6.11.20	CD's (Final-R2)	JRC
3.2.21	CD's (Final-R3: ADD STRUCT. GUY WIRES)	JRC

SL01743A  
PROM RMP GLASMAN WAY  
4700 SOUTH GLASMAN WAY  
OGDEN, UT 84403

DRAWING TITLE:  
EQUIPMENT SITE PLAN

DRAWING NO.:  
**A-1**

**EXISTING BUILDING ELEVATION**

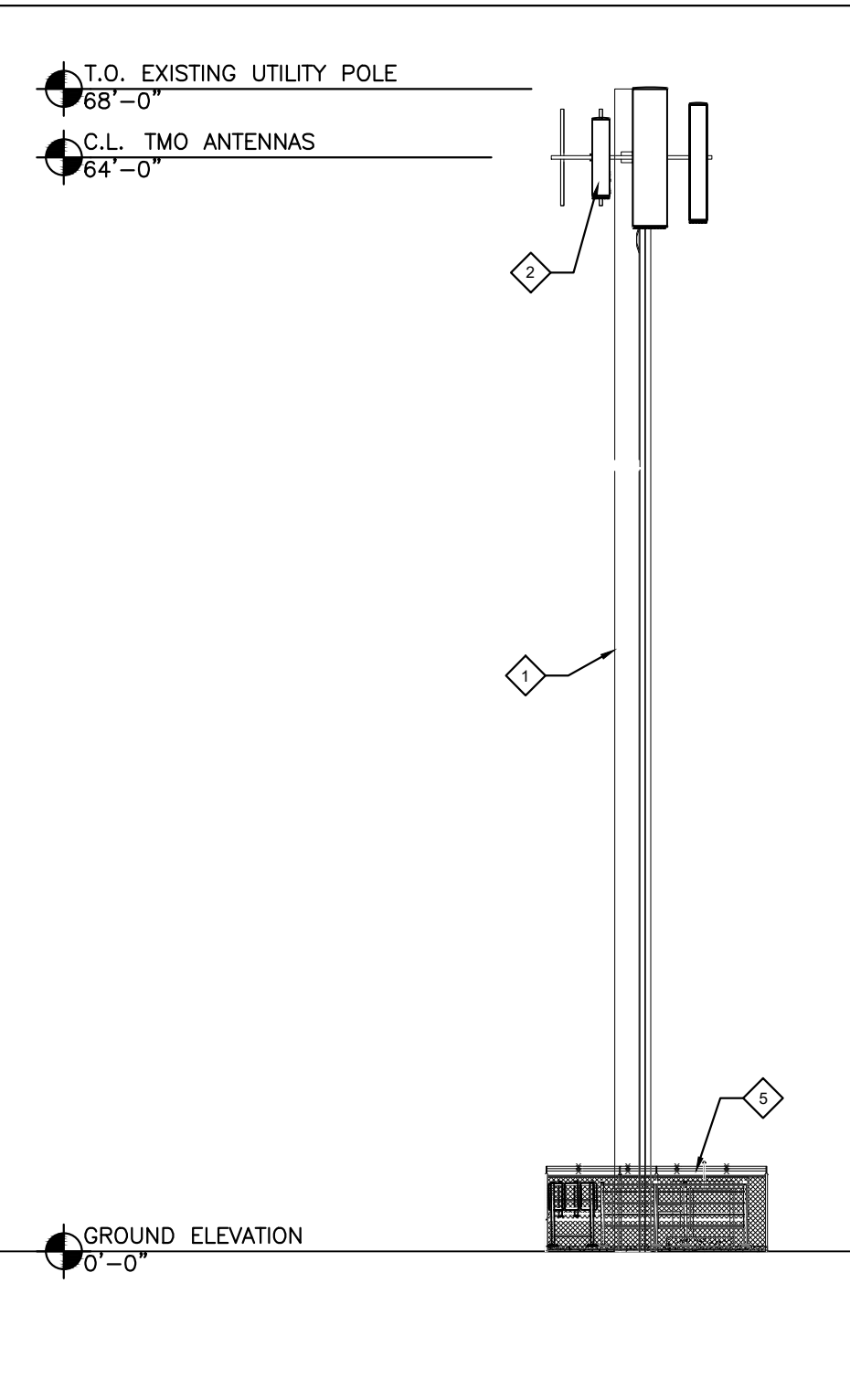

**PROPOSED BUILDING ELEVATION**

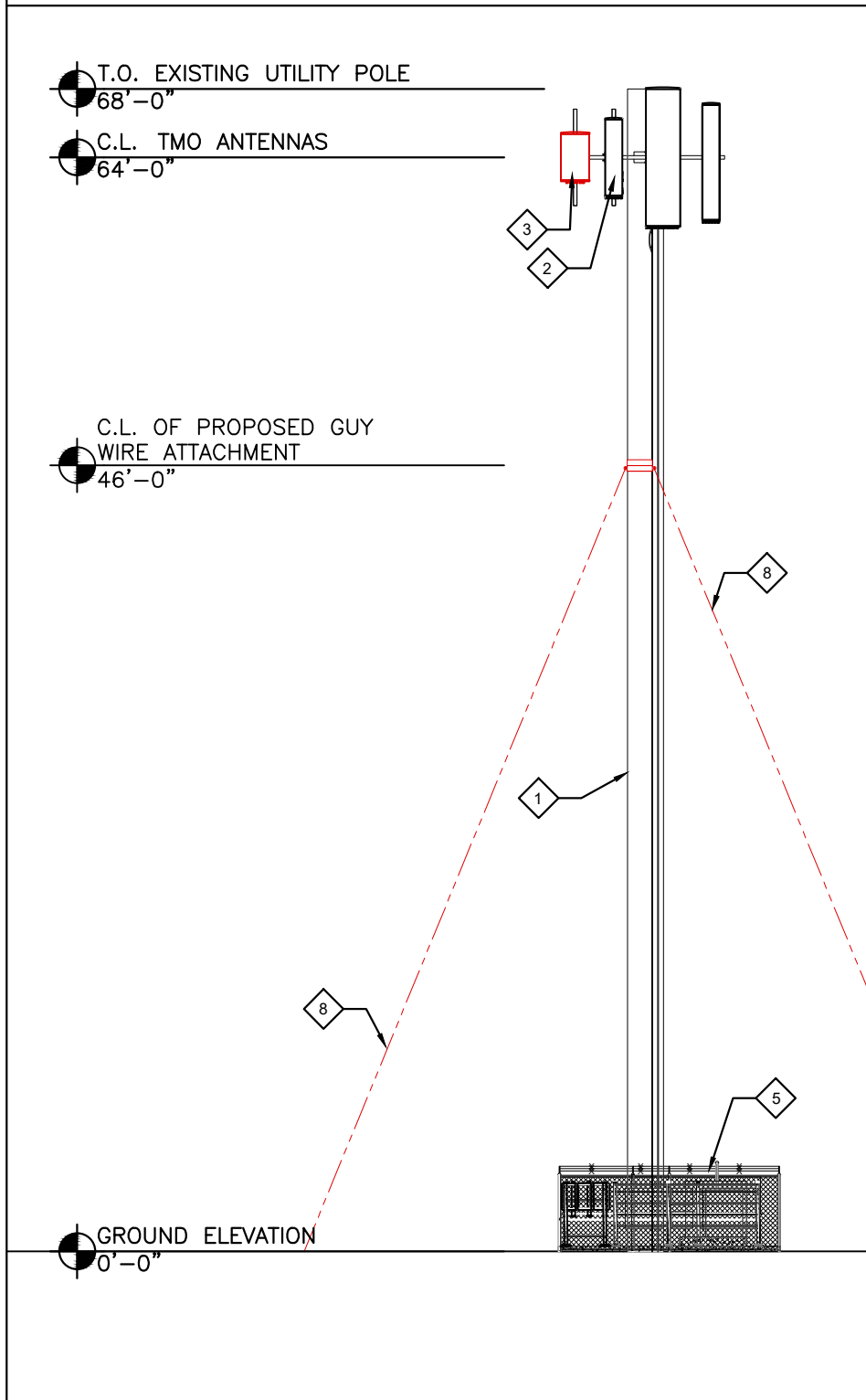

**EXISTING ANTENNA LAYOUT**

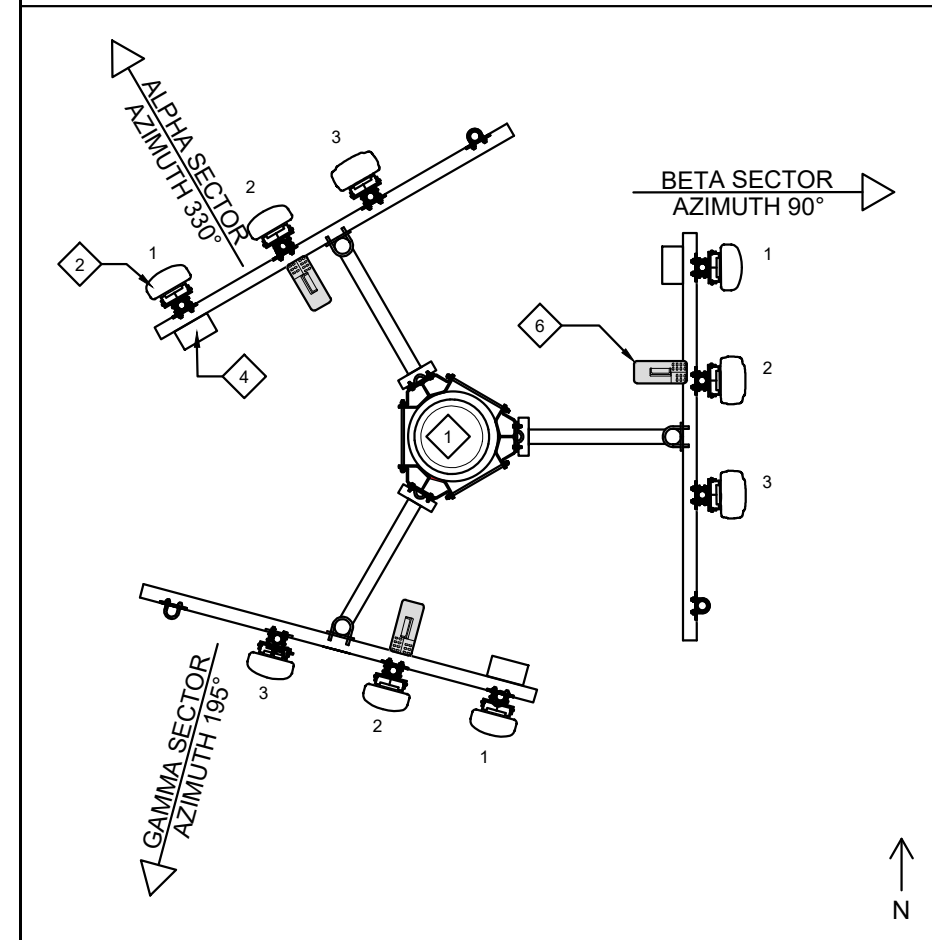

**PROPOSED ANTENNA LAYOUT**

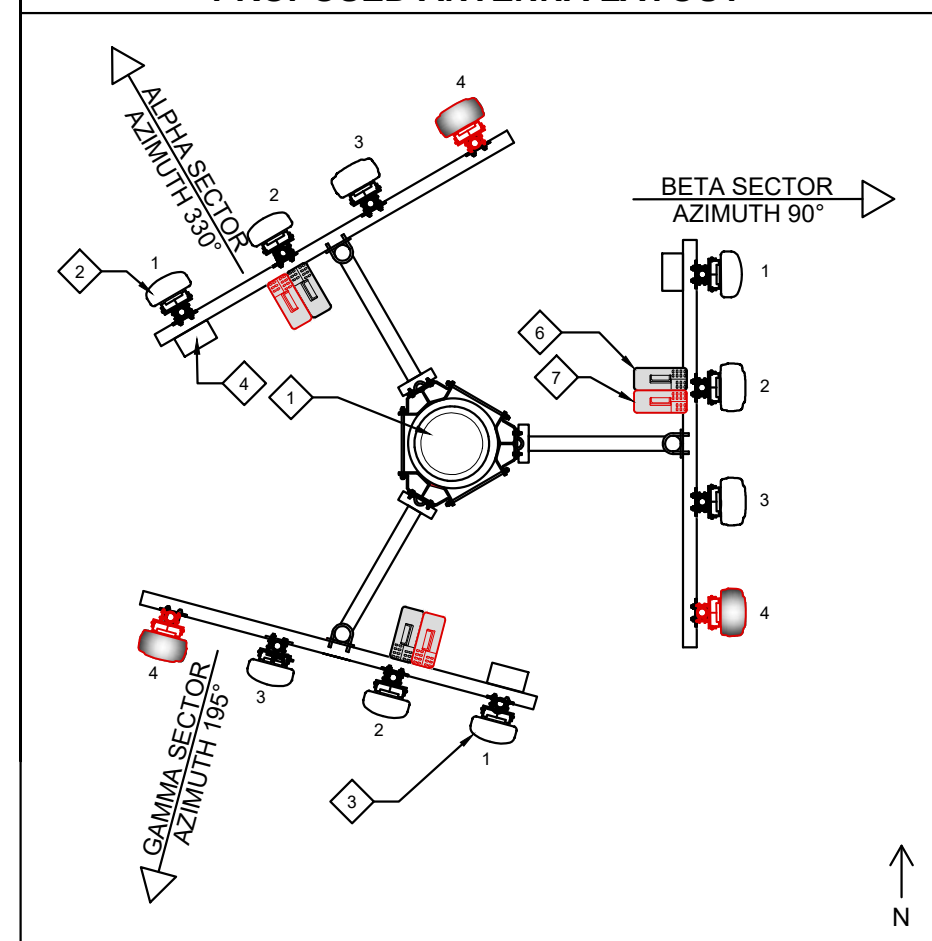

**KEY NOTES**

- 1 EXISTING 68' UTILITY POLE
- 2 EXISTING T-MOBILE ANTENNAS TO REMAIN, TYP (3) PER SECTOR
- 3 PROPOSED T-MOBILE NEW ANTENNAS, TYP (1) PER SECTOR
- 4 EXISTING TMAs TO REMAIN, TYP (1) PER SECTOR
- 5 EXISTING T-MOBILE EQUIPMENT AREA
- 6 EXISTING RRUs TO REMAIN, TYP (1) PER SECTORS
- 7 PROPOSED NEW RRUs, TYP (1) PER SECTOR
- 8 PROPOSED GUY WIRE PER STRUCTURAL ANALYSIS COMPLETED BY ANDERSON ENGINEERING DATED MARCH 2, 2021

**MECH. TILT**

ANTENNA	1/2/3/4
ALPHA	4/4/4/4
BETA	-3/-3/-3/-3
GAMMA	2/2/2/2

**ELECT. TILT**

ANTENNA	1	2	3	4
ALPHA	2	4/4/2/2	2/2/2/2	2/2
BETA	2	4/4/2/2	2/2/2/2	2/2
GAMMA	2	4/4/2/2	2/2/2/2	2/2

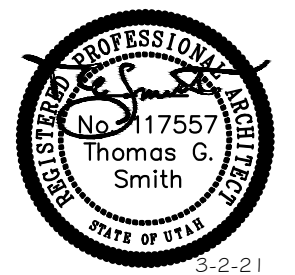

DATE: 5.29.2020  
 DRAWN BY: JRC  
 CHECKED BY: BRITTON KNAPHUS

**REVISIONS**

DATE	DESCRIPTION	INT.
5.29.20	CD's (Prelim)	JRC
6.1.20	CD's (Final)	JRC
6.9.20	CD's (Final-R1)	JRC
6.11.20	CD's (Final-R2)	JRC
3.2.21	CD's (Final-R3: ADD STRUCT. GUY WIRES)	JRC

**SL01743A**  
 PROM RMP GLASSMANN WAY  
 4700 SOUTH GLASSMANN WAY  
 OGDEN, UT 84403

DRAWING TITLE:  
 TOWER ELEVATION AND PLAN

DRAWING NO.:  
**A-2**

**ANTENNA DETAIL 1**

**CELLMAX CMA-BDHH/6521/E0-6/TB05  
(QUAD)**

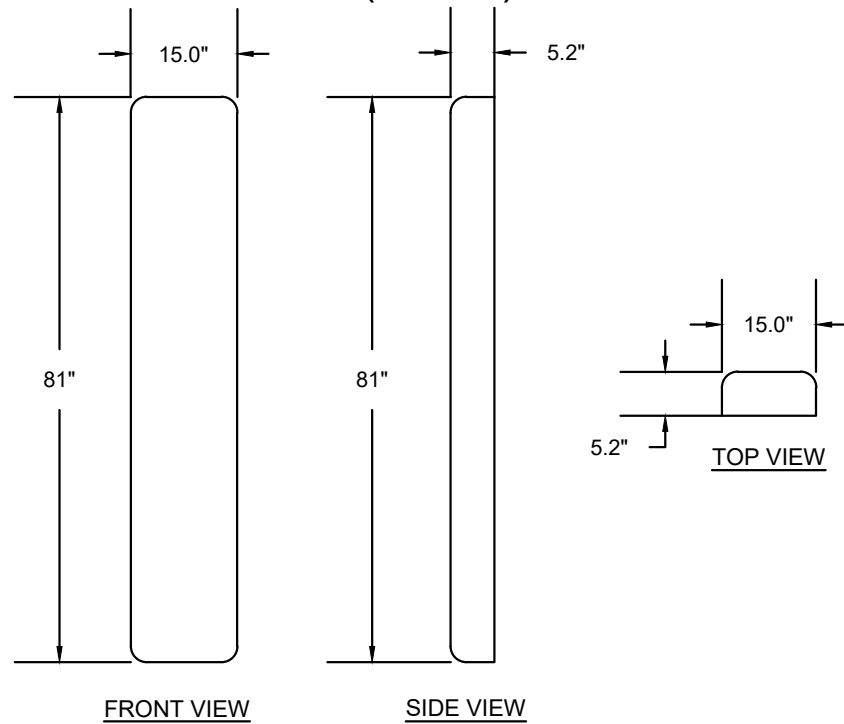

EXISTING ANTENNA TO REMAIN (3)  
(ANTENNA 1)

**ANTENNA DETAIL 2**

**RFS APXVAARR24 43-U-NA20 (OCTA)**

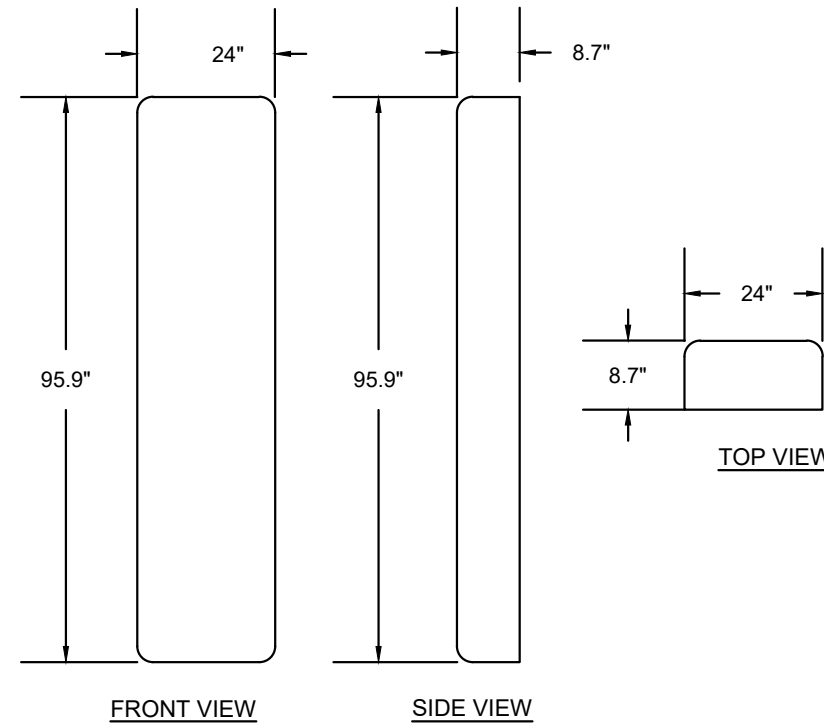

EXISTING ANTENNA TO REMAIN (3)  
(ANTENNA 2)

**ANTENNA DETAIL 3**

**ERICSSON AIR32 KRD901146-1 B66A/B2A  
(OCTA)**

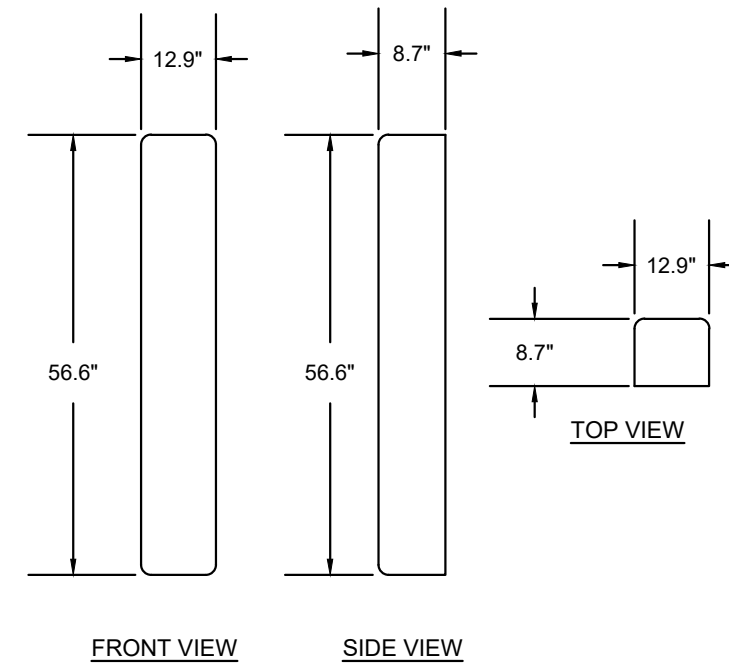

EXISTING ANTENNA TO REMAIN (3)  
(ANTENNA 3)

**ANTENNA DETAIL 4**

**ERICSSON AIR6449 B41  
(ACTIVE ANTENNA - MASSIVE MIMO)**

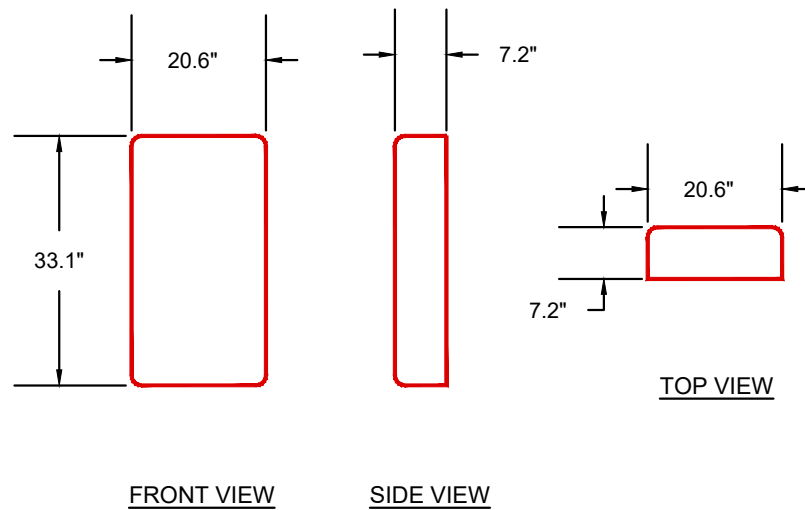

PROPOSED NEW ANTENNA (3)  
(ANTENNA 4)

**TMA DETAIL 1**

**COMMSCOPE  
GENERIC TWIN STYLE 1A - PCS  
(AtAntenna)**

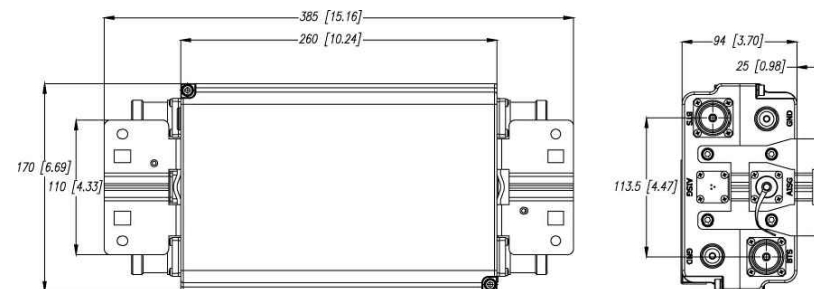

EXISTING TMA TO REMAIN (3)  
(AT ANTENNA 1)

**VOLTAGE BOOSTER DETAIL 1**

**ERICSSON  
PSU 48 13 VOLTAGE BOOSTER**



Figure 1

WEIGHT: 17.2 lbs  
DIMENSIONS (H x W x D): 1.7" x 19" x 14.3"

PROPOSED NEW (1)

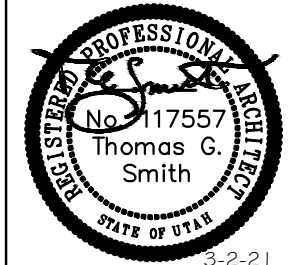

DATE: 5.29.2020

DRAWN BY: JRC

CHECKED BY: BRITTON KNAPHUS

REVISIONS		
DATE	DESCRIPTION	INT.
5.29.20	CD's (Prelim)	JRC
6.1.20	CD's (Final)	JRC
6.9.20	CD's (Final-R1)	JRC
6.11.20	CD's (Final-R2)	JRC
3.2.21	CD's (Final-R3: ADD STRUCT. GUY WIRES)	JRC

**SL01743A**  
PROM RMP GLASSMANN WAY  
4700 SOUTH GLASSMANN WAY  
OGDEN, UT 84403

DRAWING TITLE: EQUIPMENT DETAIL  
DRAWING NO.: **A-3**

**RRU DETAIL 1**

**ERICSSON  
4449 B71+B85**



WEIGHT: ±74.9 lbs  
DIMENSIONS (H x W x D): 17.9" x 13.1" x 10.6"

**EXISTING RRU TO REMAIN (3)  
(AT ANTENNA 2)**

**RRU DETAIL 2**

**ERICSSON  
4415 B25**



WEIGHT: 44 lbs  
DIMENSIONS (H x W x D): 16.5" x 13.5" x 5.9"mm

**PROPOSED NEW RRU (3)  
(AT ANTENNA 2)**

**CABINET DETAIL 1**

**ERICSSON 6160**

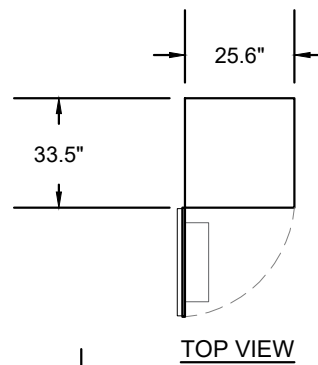

TOP VIEW

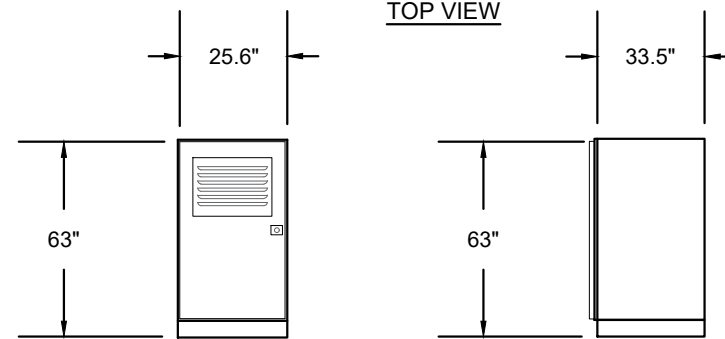

FRONT VIEW

SIDE VIEW

**PROPOSED NEW CABINET**

**CABINET DETAIL 2**

**ERICSSON B160**

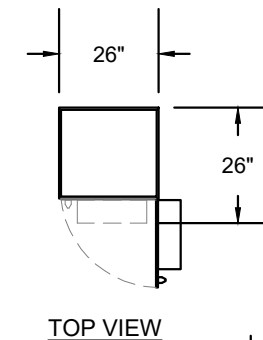

TOP VIEW

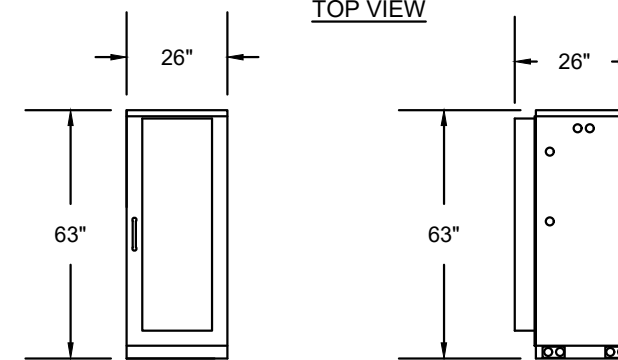

FRONT VIEW

SIDE VIEW

**PROPOSED NEW BATTERY CABINET**

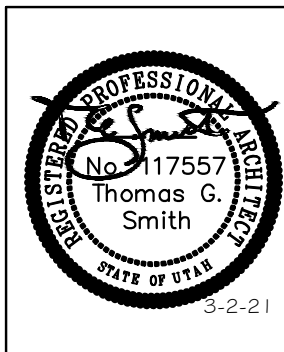

DATE: 5.29.2020

DRAWN BY: JRC

CHECKED BY: BRITTON KNAPHUS

**REVISIONS**

DATE	DESCRIPTION	INT.
5.29.20	CD's (Prelim)	JRC
6.1.20	CD's (Final)	JRC
6.9.20	CD's (Final-R1)	JRC
6.11.20	CD's (Final-R2)	JRC
3.2.21	CD's (Final-R3: ADD STRUCT. GUY WIRES)	JRC

**SL01743A**  
PROM RMP GLASSMANN WAY  
4700 SOUTH GLASSMANN WAY  
OGDEN, UT 84403

DRAWING TITLE:  
**EQUIPMENT DETAIL**

DRAWING NO.:  
**A-4**

# GROUNDING PLAN

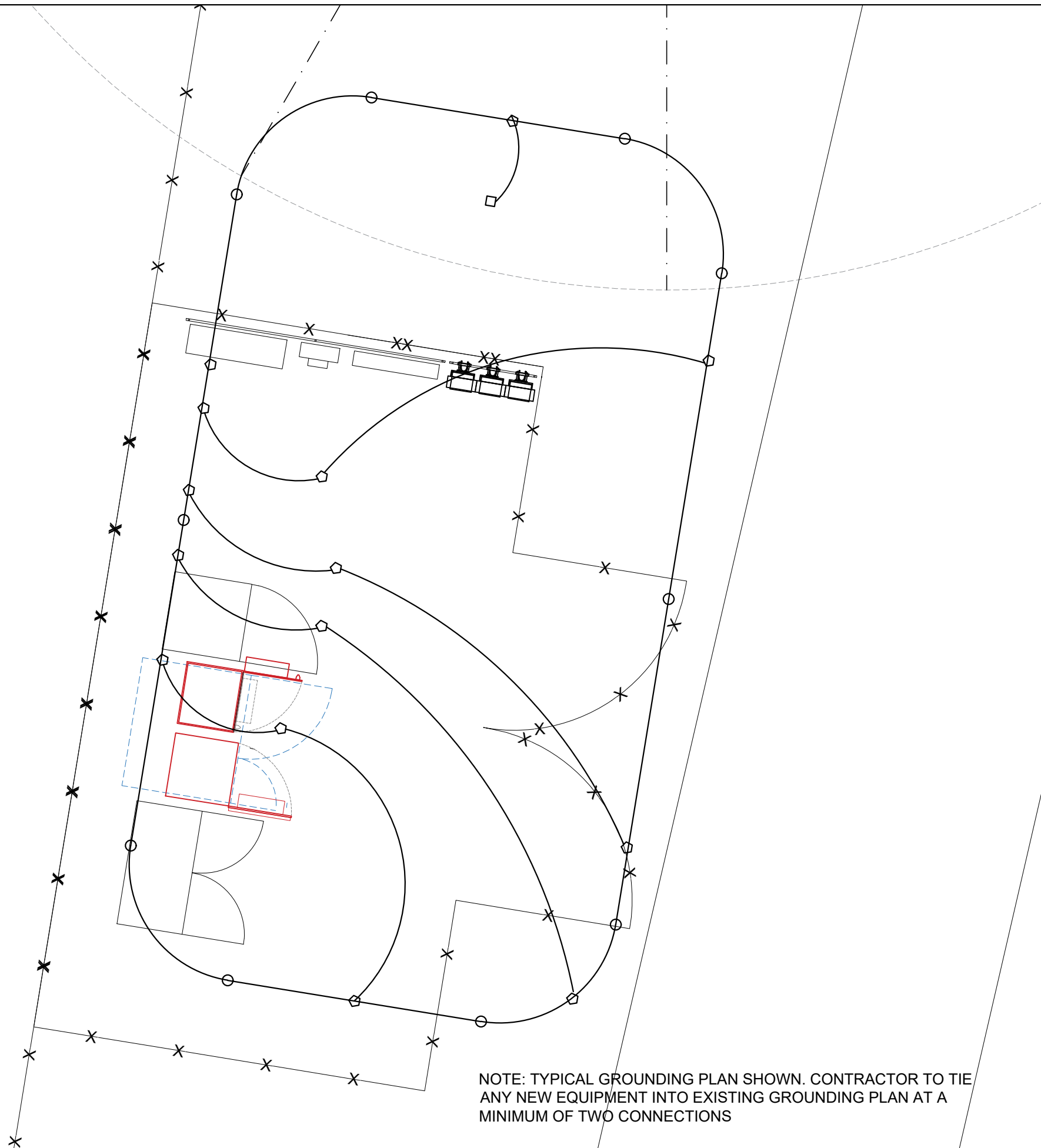

NOTE: TYPICAL GROUNDING PLAN SHOWN. CONTRACTOR TO TIE ANY NEW EQUIPMENT INTO EXISTING GROUNDING PLAN AT A MINIMUM OF TWO CONNECTIONS

# GROUNDING NOTES

1. ALL SAFETY GROUNDING OF THE ELECTRICAL EQUIPMENT SHALL BE CARRIED OUT IN ACCORDANCE WITH THE CURRENT REVISION OF NEC.
2. ALL DETAILS ARE SHOWN IN GENERAL TERMS. ACTUAL INSTALLATION AND SITE CONSTRUCTION MAY VARY DUE TO SITE SPECIFIC CONDITIONS. IF SITE SOIL CONDITIONS ARE CORROSIVE, USE OF A LARGER MAIN GROUND RING CONDUCTOR MAY BE NECESSARY.
3. GROUND ALL ANTENNA BASES, FRAMES, CABLE RUNS, AND OTHER METALLIC COMPONENTS USING GROUND WIRES AND CONNECT TO SURFACE MOUNTED BUS BARS. FOLLOW ANTENNA AND BTS MANUFACTURERS PRACTICES FOR GROUNDING REQUIREMENTS. GROUND COAX SHIELD AT BOTH ENDS AND EXIT FROM TOWER OR MONOPOLE USING MANUFACTURERS PRACTICES.
4. ALL GROUND CONNECTIONS SHALL BE CADWELD. ALL WIRES SHALL BE COPPER THHN/THWN. ALL GROUND WIRE SHALL BE SOLID COPPER WITH GREEN INSULATED WIRE ABOVE GROUND.
5. CONTRACTOR TO VERIFY AND TEST GROUND TO SOURCE TO A MAXIMUM OF 5 OHMS. IF GROUND TEST DID NOT ACHIEVE THE MAXIMUM 5 OHMS, CONTRACTOR SHALL BE RESPONSIBLE TO PROVIDE ADDITIONAL GROUNDING TO OHM MAX REQUIREMENT. GROUNDING AND OTHER OPERATIONAL TESTING WILL BE WITNESSED BY A T-MOBILE REPRESENTATIVE.
6. ELECTRICAL CONTRACTOR TO PROVIDE DETAILED DESIGN OF GROUNDING SYSTEM, AND RECEIVE APPROVAL OF DESIGN BY AN AUTHORIZED T-MOBILE REPRESENTATIVE, PRIOR TO INSTALLATION OF GROUNDING SYSTEM.
7. NOTIFY T-MOBILE IF THERE ARE ANY DIFFICULTIES INSTALLING GROUND SYSTEM DUE TO SITE SOIL CONDITIONS.
8. IF SURGE SUPPRESSER IS AN EXTERIOR MOUNT, RUN A #2 THHN GROUND WIRE IN A 1" SCHED. 40 PVC CONDUIT TO SIDE SPLICE CADWELD AT GROUND RING. HEAT RADIUS CONDUIT TO PRODUCE LARGE RADIUS BENDS. STRAP TO SLAB AT A MINIMUM OF TWO POINTS.
9. ALL GROUNDING WIRE RUNS AND CONNECTIONS, BOTH ABOVE AND BELOW GRADE, SHALL BE LOCATED INSIDE OF THE LEASE AREA.
10. TIE NEW GROUNDING INTO EXISTING GROUND GRID IN AT LEAST TWO LOCATIONS.
11. THE INFORMATION CONTAINED IN THIS SET OF CONSTRUCTION DOCUMENTS IS PROPRIETARY BY NATURE. ANY USE OR DISCLOSURE OTHER THAN THAT WHICH RELATES TO T-MOBILE SERVICES IS STRICTLY PROHIBITED.

### SYMBOL KEY

- ◻ MECHANICAL CONNECTION
- COPPER GROUND ROD
- △ CADWELD CONNECTION
- GROUND BAR

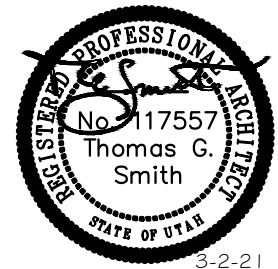

DATE: 5.29.2020  
 DRAWN BY: JRC  
 CHECKED BY: BRITTON KNAPHUS

### REVISIONS

DATE	DESCRIPTION	INT.
5.29.20	CD's (Prelim)	JRC
6.1.20	CD's (Final)	JRC
6.9.20	CD's (Final-R1)	JRC
6.11.20	CD's (Final-R2)	JRC
3.2.21	CD's (Final-R3: ADD STRUCT. GUY WIRES)	JRC

SL01743A  
 PROM RMP GLASSMANN WAY  
 4700 SOUTH GLASSMANN WAY  
 OGDEN, UT 84403

DRAWING TITLE:  
 GROUNDING PLAN

DRAWING NO.:  
**E-1**

# TYPICAL GROUNDING DETAIL

1

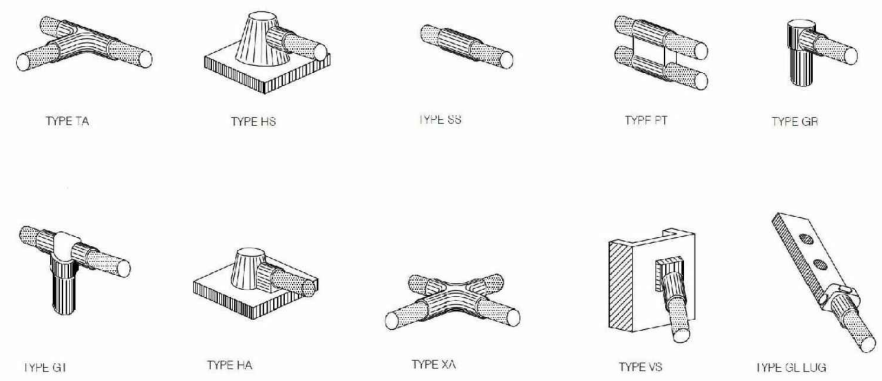

NOTE: CADWELD "TYPES" SHOWN ARE EXAMPLES - CONSULT WITH PROJECT MANAGER FOR SPECIFIC TYPES OF CADWELDS TO BE USED FOR THIS PROJECT

## CADWELD DETAILS

3

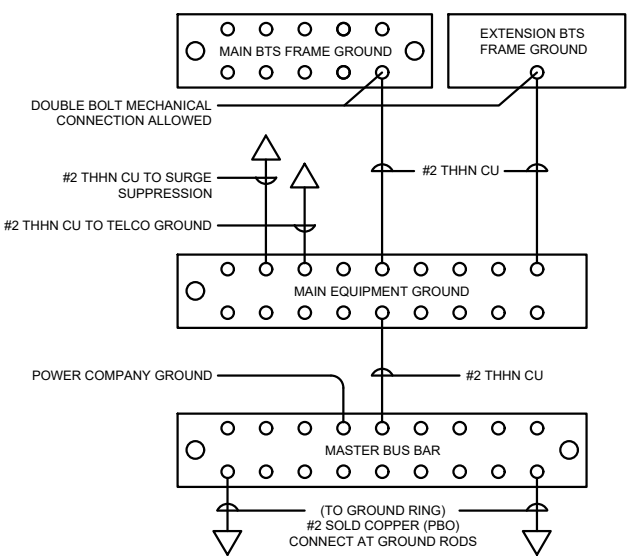

## GROUNDING SCHEMATIC

2

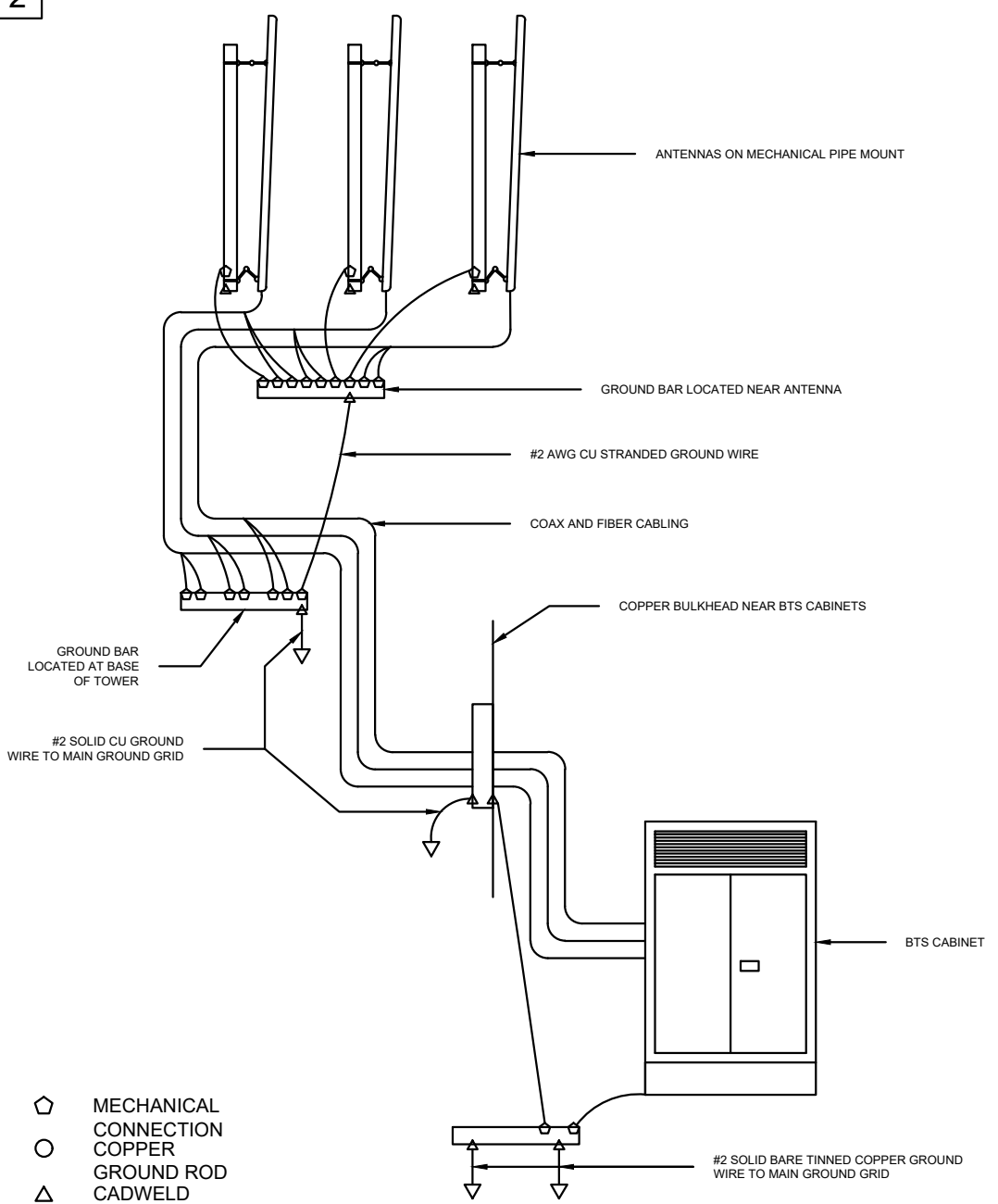

## ANTENNA GROUNDING DIAGRAM

- ◇ MECHANICAL CONNECTION COPPER
- GROUND ROD
- △ CADWELD CONNECTION
- GROUND BAR

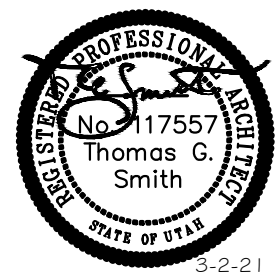
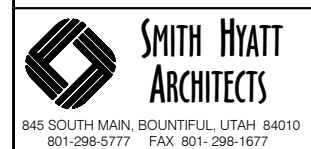

DATE: 5.29.2020  
 DRAWN BY: JRC  
 CHECKED BY: BRITTON KNAPHUS

REVISIONS		
DATE	DESCRIPTION	INT.
5.29.20	CD's (Prelim)	JRC
6.1.20	CD's (Final)	JRC
6.9.20	CD's (Final-R1)	JRC
6.11.20	CD's (Final-R2)	JRC
3.2.21	CD's (Final-R3: ADD STRUCT. GUY WIRES)	JRC

SL01743A  
 PROM RMP GLASMAN WAY  
 4700 SOUTH GLASMAN WAY  
 OGDEN, UT 84403

DRAWING TITLE:  
 POWER, TELEPHONE, GROUNDING

DRAWING NO.:  
**E-2**



## TYPICAL GROUNDING SYSTEM NOTES

1. TOWER RADIAL GROUND:  
#2 SOLID COPPER WIRE CADWELDED (OR FASTENER APPROVED BY PROJECT MANAGER) TO TOWER BASE. EXTEND WIRE 30' MINIMUM IN SWEEPING CONFIGURATION AT A MINIMUM DEPTH OF 24". ALL GROUND RODS TO BE 8' COPPER OR COPPER CLAD. FIRST GROUND RODS FROM TOWER ARE TO BE PLACED 10' EQUAL DISTANCE (BETWEEN ROD CENTERS) AND A MINIMUM OF EVERY 10' ALONG TOTAL LENGTH. ALL BENDS MUST MAINTAIN A MINIMUM 12" RADIUS.
2. TOWER EQUIPMENT RING GROUND INTERCONNECT:  
ONLY ONE CONNECTION OF THIS TYPE FOR EACH TOWER. SAME CONSTRUCTION AS NOTE 1 ABOVE EXCEPT THE TERMINATION AT THE GROUNDING RING MUST BE THREE-WAY CONNECTED. ALL BENDS MUST MAINTAIN A MINIMUM 12" RADIUS.
3. EQUIPMENT BUILDING RING GROUND:  
ALWAYS OBSERVE THE TURN DIRECTIONS SHOWN WHEN PLACING BENDS OR CONNECTIONS. USE #2 SOLID COPPER WIRE PLACED WITHIN 3' (+/- 6") FROM EDGE OF BUILDING CONCRETE FOUNDATION AT A MINIMUM DEPTH OF 24". ALL CONNECTIONS TO GROUND RING ARE TO BE CADWELDED. ALL GROUND RODS TO BE 10' COPPER OR COPPER CLAD AND PLACED 10' EQUAL DISTANCE (BETWEEN ROD CENTERS) AND A MINIMUM OF EVERY 10' ALONG TOTAL LENGTH. ALL BENDS MUST MAINTAIN A MINIMUM 12" RADIUS.
4. SINGLE POINT GROUND BAR (COAX BULKHEAD):  
ALWAYS OBSERVE THE DIRECTIONS SHOWN WHEN PLACING BENDS OR CONNECTIONS TO GROUND RING. USE TWO #2 SOLID COPPER WIRE OR TWO 3" COPPER RIBBONS ATTACHED ON OPPOSITE ENDS OF BAR OR BULKHEAD EXTENDING DIRECTLY TO GROUND. ALL WIRE CONNECTIONS TO GROUND RING ARE TO BE CADWELDED. RIBBONS MAY BE ATTACHED TO GROUND RING WITH A "LISTED" PRESSURE CONNECTION WITH APPROVAL OF CONSTRUCTION MANAGER. ALL BENDS MUST MAINTAIN A MINIMUM 12" RADIUS.
5. EQUIPMENT SHELTER INNER BONDING RING:  
#2 SOLID COPPER WIRE CADWELDED (TO INNER BONDING RING AT A LOCATION EITHER ABOVE THE SOIL LINE OR JUST INSIDE INTERIOR OF BUILDING. ALWAYS USE PVC (NONMETALLIC) SLEEVES WHEN ENTERING THE STRUCTURE. THIS TYPE OF BOND IS REQUIRED AT EACH OUTSIDE CORNER AND AT DISTANCES NOT TO EXCEED 50' ALONG ANY STRAIGHT WALL. ALL BENDS MUST MAINTAIN A MINIMUM 12" RADIUS.
6. FENCE EQUALIZATION BOND:  
#2 SOLID COPPER WIRE CADWELDED TO BUILDING RING GROUND AND ATTACHED TO EACH INSIDE OR OUTSIDE CORNER FENCE POST AND/OR GATE POST WITH A "LISTED" WIRE CLAMP. PLACE AT A MINIMUM 12" DEPTH (SEE NOTE 11 BELOW FOR CROSSING CLEARANCES). IF METALLIC POST IS NOT SET IN CEMENT, PLACE AN ADDITIONAL 8' GROUND ROD AT POST LOCATION.
7. GATE EQUALIZATION BOND:  
#2 SOLID COPPER WIRE CADWELDED TO FENCE EQUALIZATION WIRE AND ATTACHED TO EACH GATE POST WITH A "LISTED" WIRE CLAMP. IF METALLIC POST IS NOT SET IN CEMENT, PLACE AN ADDITIONAL 10' GROUND ROD AT EACH POST LOCATION.
8. POWER / TELEPHONE TRENCH:  
UTILITIES CAN EITHER BE PLACED IN SAME TRENCH (NESC RANDOM SEPARATION) OR IN SEPARATE TRENCH AT A 36" DEPTH. ALWAYS PLACE THESE FACILITIES BELOW WHILE MAINTAINING A 36" HORIZONTAL SEPARATION AND A 12" VERTICAL SEPARATION FROM ANY RADIAL OR RING GROUND SYSTEMS IN, ON, OR ADJACENT TO THE RADIO SITE.
9. POWER / TELEPHONE ENTRANCE:  
THE BUILDING RING GROUND MEETS OR EXCEEDS THE NEC ARTICLE 250 UTILITY PROTECTION GROUND. THEREFORE, INFORM LOCAL INSPECTOR THAT ADDITIONAL GROUND RODS ARE NOT REQUIRED. ALL UTILITY GROUNDS MAY BE ATTACHED TO THE #2 SOLID COPPER WIRE DETAILED IN NOTE 10 BELOW. IF LOCAL POWER COMPANY CODES REQUIRE AN ADDITIONAL GROUND ROD, BOND THE TWO FACILITIES TOGETHER AT THIS LOCATION.
10. UTILITY GROUNDING ELECTRODE BOND:  
USE #2 SOLID COPPER WIRE PLACED WITHIN 3' OF UTILITY ENTRANCE AT DEMARCATION CABINET ENTRY PORT. ALL CONNECTIONS TO GROUND RING ARE TO BE CADWELDED. CONNECTION TO DEMARCATION CABINET ENTRY PORT TO BE WITH A "LISTED" CONNECTION. ALL BENDS MUST MAINTAIN A MINIMUM 12" RADIUS.
11. RADIAL GROUND / FENCE BOND CROSSINGS:  
WHEREVER PRACTICAL, TO REDUCE MAGNETIC COUPLING, THESE FACILITIES MUST CROSS AT A 90 DEGREE ANGLE WHILE MAINTAINING 18" VERTICAL SEPARATION.
12. COAX GROUNDING KITS:  
USE INDIVIDUAL "LISTED" GROUNDING KITS FOR EACH COAX CABLE. BOND TO TOWER BONDING BUSS BAR WITH #2 THHN SOLID COPPER WIRE WITH 2 HOLE CRIMPED CONNECTIONS.
13. GROUNDING BUSS BAR KIT:  
THE GROUNDING BUSS BAR AND ATTACHMENT KIT MUST BE DIRECTLY BOLTED TO THE TOWER STRUCTURE WITHOUT ELECTRICAL INSULATORS.
14. ICE BRIDGE BONDING:  
THE ICE BRIDGE SHOULD NOT BE BONDED TO THE TOWER STRUCTURE. IT SHOULD ONLY BE BONDED AT ONE END TO THE ENTRANCE BULKHEAD (SINGLE POINT GROUND BAR). USE #2 THHN SOLID COPPER WIRE WITH 2 HOLE CRIMPED CONNECTIONS.
15. RADIO BAY TO COAX BULKHEAD BOND:  
THIS IS THE ONLY CABINET TO GROUND BOND WIRE ATTACHED TO THE RADIO BAY. USE #2 THHN SOLID COPPER WIRE WITH 2 HOLE CRIMPED CONNECTIONS OR A 3" COPPER STRAP.
16. RADIO BAY ISOLATION KIT:  
CONTACT RADIO EQUIPMENT SUPPLIER FOR SPECIFICATION AND INSTALLATION PROCEDURES.

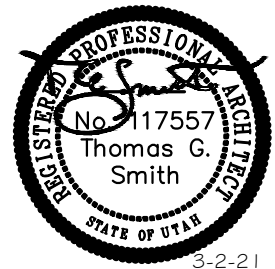

DATE: 5.29.2020

DRAWN BY: JRC

CHECKED BY: BRITTON KNAPHUS

### REVISIONS

DATE	DESCRIPTION	INT.
5.29.20	CD's (Prelim)	JRC
6.1.20	CD's (Final)	JRC
6.9.20	CD's (Final-R1)	JRC
6.11.20	CD's (Final-R2)	JRC
3.2.21	CD's (Final-R3: ADD STRUCT. GUY WIRES)	JRC

**SL01743A**  
**PROM RMP GLASSMANN WAY**  
 4700 SOUTH GLASSMANN WAY  
 OGDEN, UT 84403

DRAWING TITLE:

SITE NOTES

DRAWING NO.:

E-3

DATE: 2-MAR-21  
 DRAWN BY: MBD  
 CHECKED BY: RDE  
 FILE: SL01743A

REVISIONS		
DATE	DESCRIPTION	INITIAL

**T-Mobile**  
 121 WEST ELECTION RD  
 SUITE 330  
 DRAPER, UT 84020  
 801-816-4422  
 FAX 801-816-4420

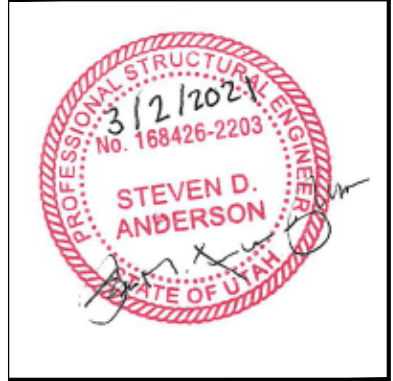

RAGE  
 DEVELOPMENT LLC



SITE NUMBER:  
**SL01743A**  
 SITE NAME: RMP GLASSMAN WAY  
 CITY, STATE: OGDEN, UT  
 SHEET: UTILITY POLE PLAN VIEW

**S-1**

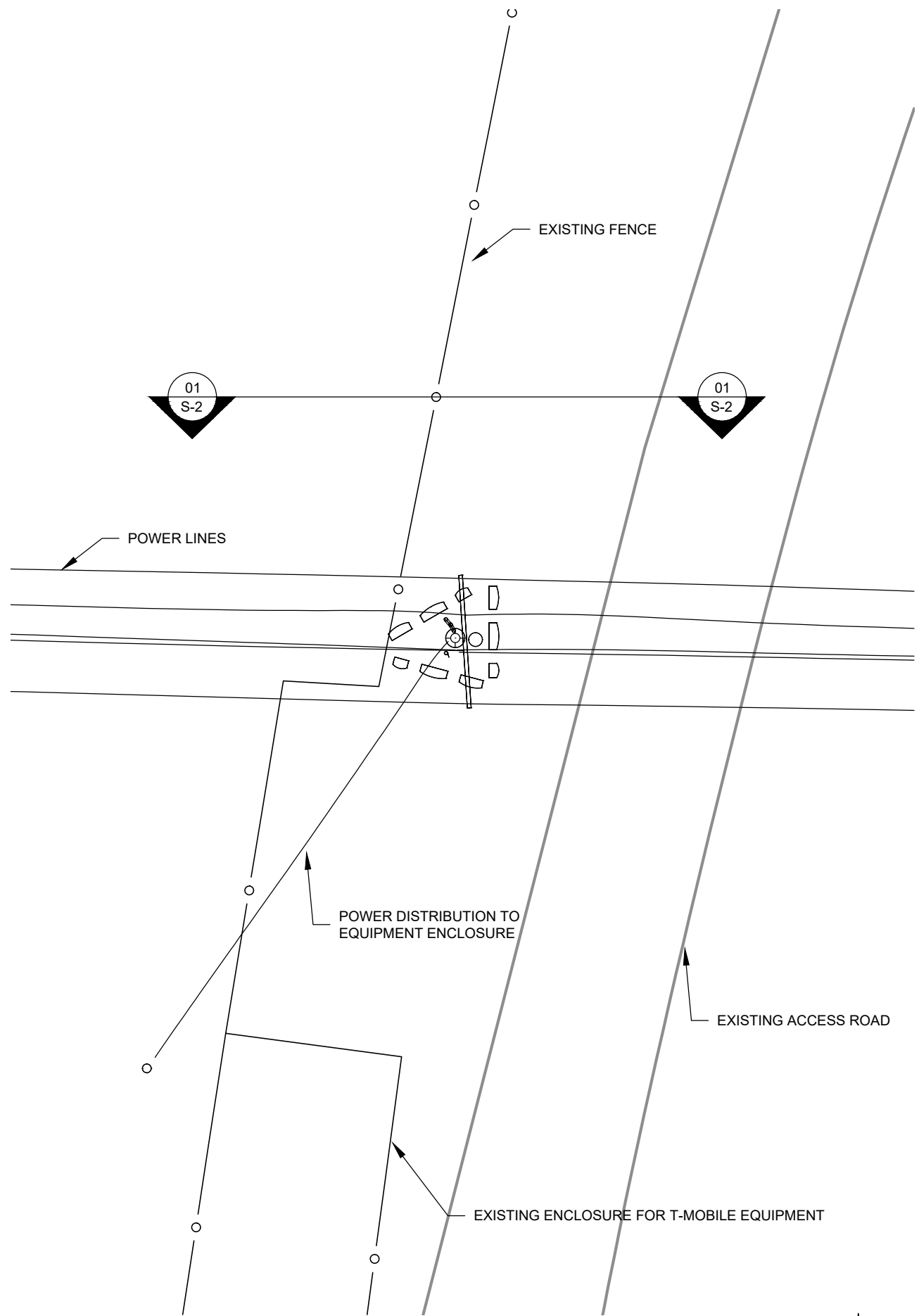

**PLAN VIEW - EXISTING** 1  
 SCALE - 1" = 10'

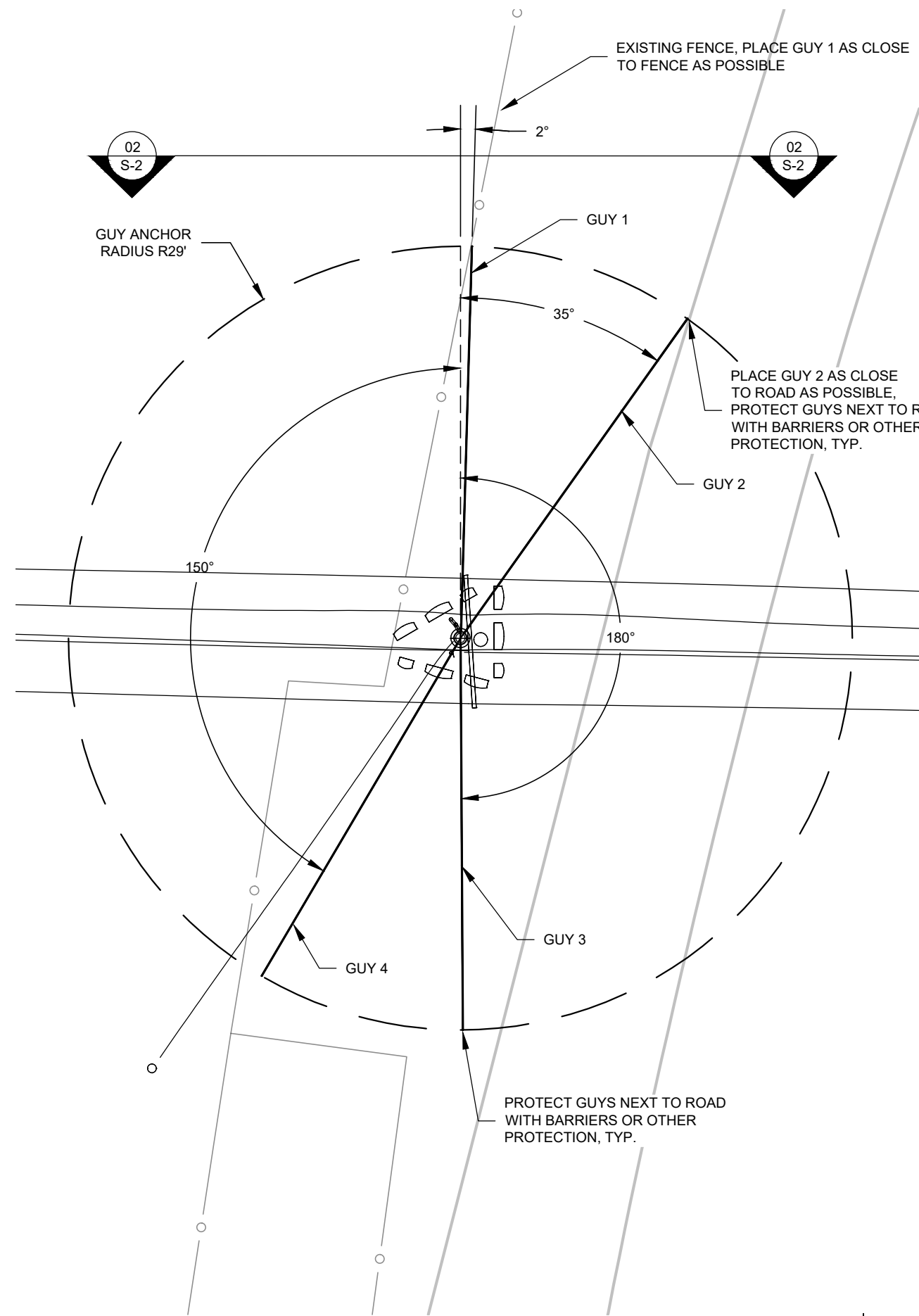

**PLAN VIEW - PROPOSED** 2  
 SCALE - 1" = 10'

C:\Users\mdoney\Anderson\_Engineering Co., Inc\Structures - RAGE\SL01743A FROM RMP GLASSMAN WAY 2021\From Glassman Way.dwg

DATE: 2-MAR-21  
 DRAWN BY: MBD  
 CHECKED BY: RDE  
 FILE: SL01743A

REVISIONS		
DATE	DESCRIPTION	INITIAL

**T-Mobile**  
 121 WEST ELECTION RD  
 SUITE 330  
 DRAPER, UT 84020  
 801-816-4422  
 FAX 801-816-4420

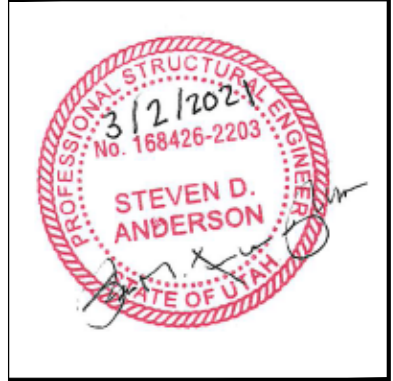

RAGE  
 DEVELOPMENT LLC



SITE NUMBER:  
**SL01743A**  
 SITE NAME: RMP GLASSMAN WAY  
 CITY, STATE: OGDEN, UT  
 SHEET: UTILITY POLE ELEVATIONS

**S-2**

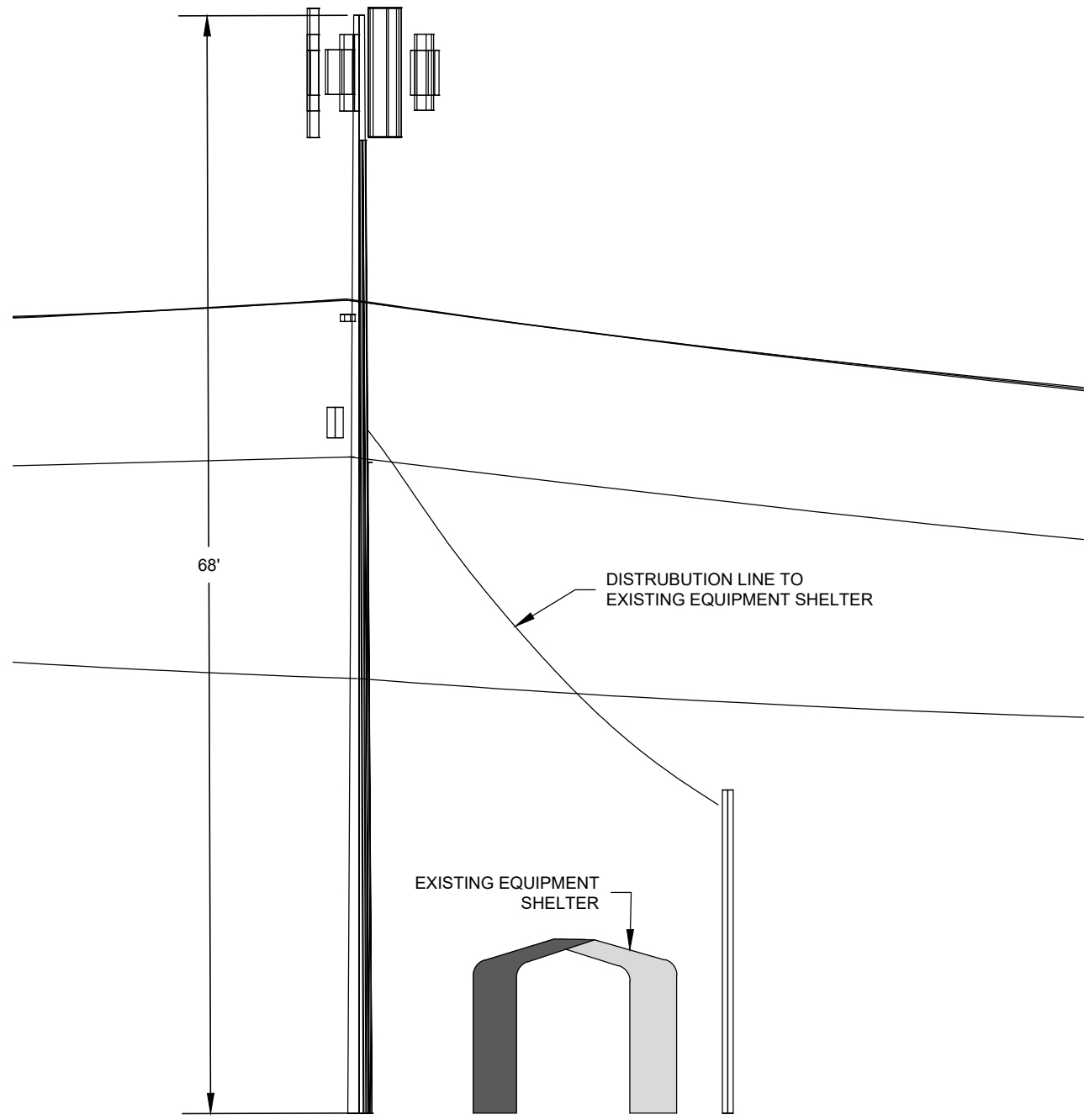

**NORTH ELEVATION VIEW - EXISTING** 1  
 SCALE - 1" = 10'

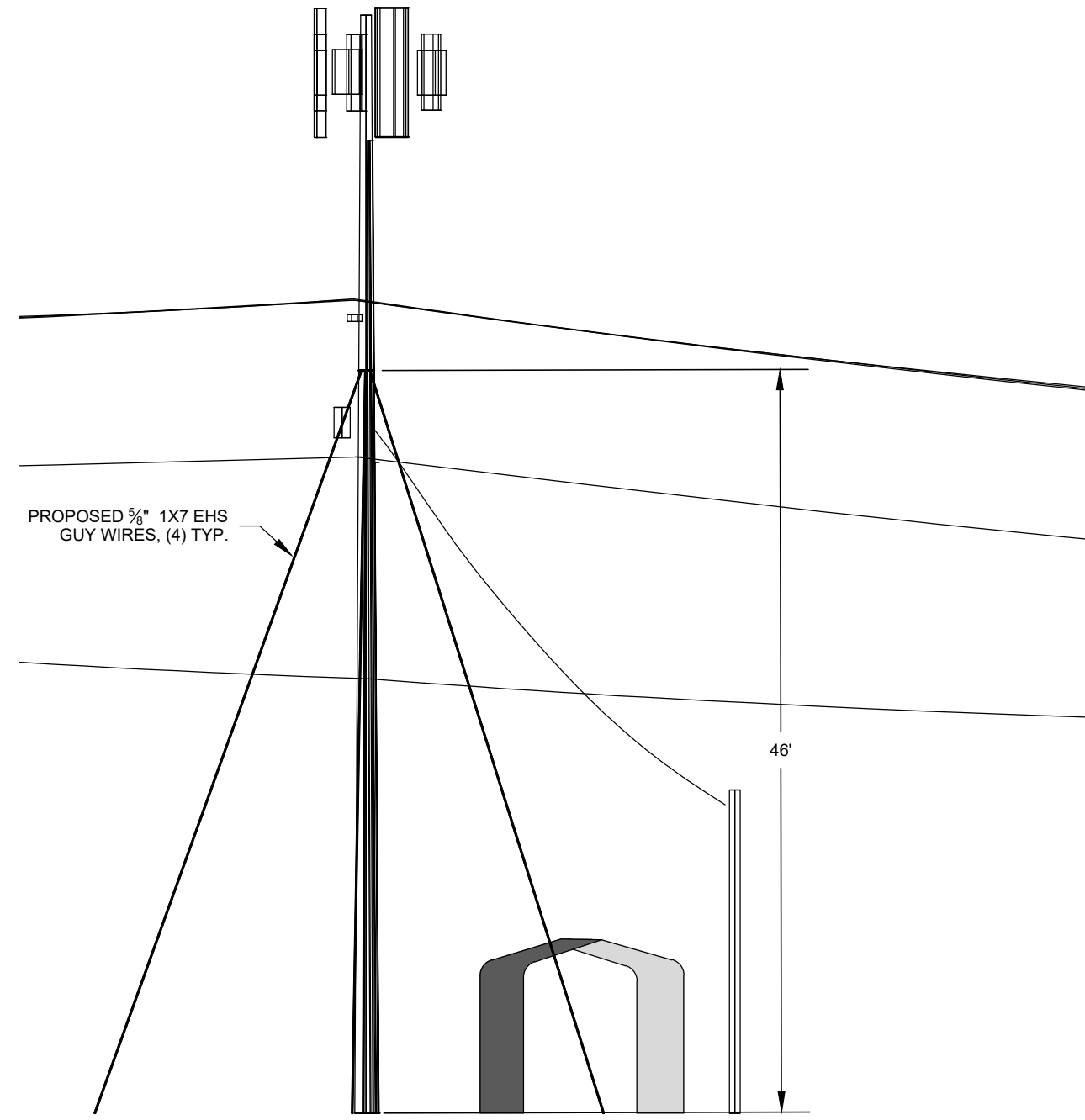

**NORTH ELEVATION VIEW - PROPOSED** 2  
 SCALE - 1" = 10'

C:\Users\mdoney\Anderson\_Engineering Co., Inc\Structures - RAGE\SL01743A FROM RMP GLASSMAN WAY 2021\From Glassman Way.dwg

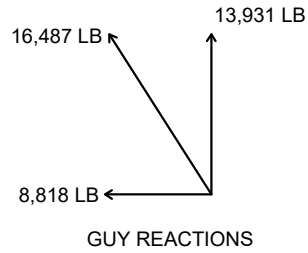
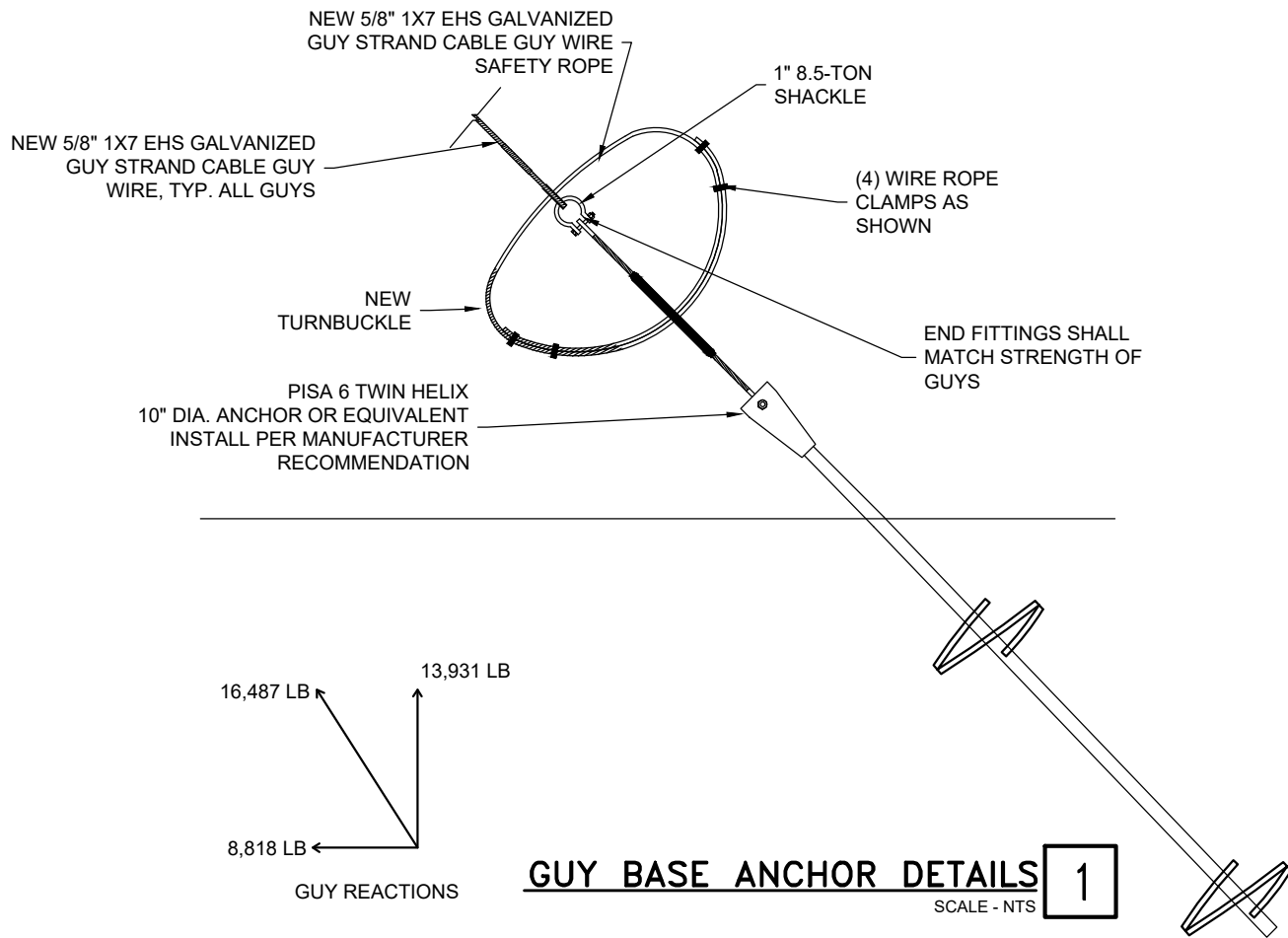

**GUY BASE ANCHOR DETAILS 1**  
SCALE - NTS

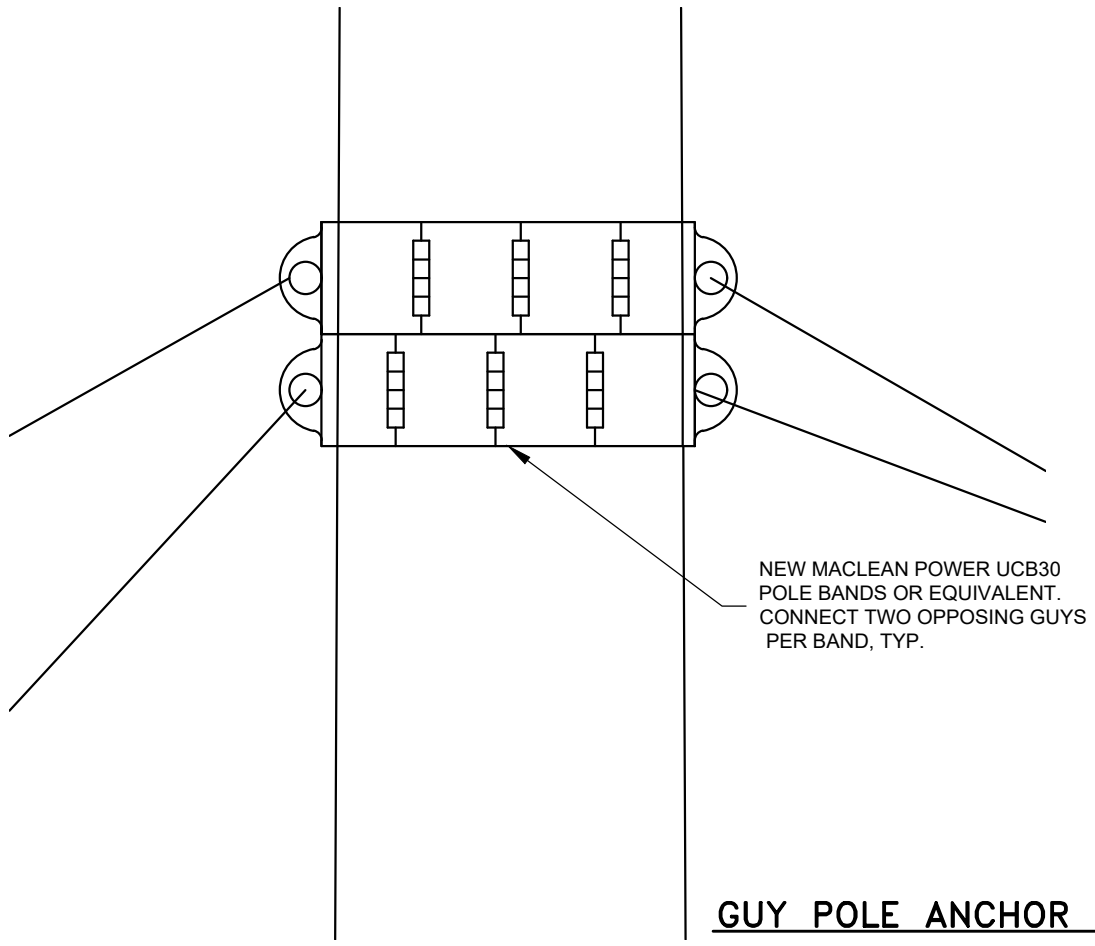

**GUY POLE ANCHOR DETAILS 2**  
SCALE - NTS

**GENERAL NOTES:**

1. ADHERE TO ALL OSHA AND NESC SAFETY STANDARDS & WARNINGS FOR GUYED UTILITY POLES.
2. CONTRACTOR RESPONSIBLE FOR RETROFIT TO HAVE EXTENSIVE EXPERIENCE WITH GUYED UTILITY POLE ERECTION & MODIFICATION.
3. ALL NEW METAL CONNECTIONS AND WIRE ROPE TO BE PROTECTED FOR CORROSION RESISTANCE.
4. ALL CONNECTIONS AT WIRE ROPE GROUND ANCHORAGE AND AT TOWER TO WIRE ROPE, TO BE RATED FOR AN ULTIMATE/BREAKING FORCE OF 1.5 TIMES CAPACITY OF THE NEW CABLE.
5. PROVIDE LOCK WASHERS FOR ALL NEW BOLTED CONNECTIONS.
6. CONTRACTOR TO NOTIFY CONTRACT REPRESENTATIVE IF ANY EXISTING MEMBER, CONNECTION OR GUY SHOWS ABNORMAL SIGNS OF STRESS, WEAR, OR IMPROPER INSTALLATION.
7. PROVIDE TEMPORARY SUPPORT AT BASE OF TOWER DURING CONSTRUCTION. SUBMIT TEMPORARY SUPPORT PLAN TO CONTRACT REPRESENTATIVE FOR REVIEW.
8. ALL GUY WIRES MATERIALS, CONNECTORS, AND OTHER ASSOCIATED EQUIPMENT SHALL MEET THE REQUIREMENTS AND BE INSTALLED IN ACCORDANCE WITH TIA-222-H AND NESC.
9. STEEL GUY ANCHORAGES IN DIRECT CONTACT WITH THE SOIL SHALL AS A MINIMUM, HAVE CORROSION CONTROL IN ACCORDANCE WITH TIA-222 (5.6.2)
10. INSTALLATION SHALL BE IN ACCORDANCE WITH DESIGN DOCUMENTS, INSTALLATION DOCUMENTS AND THE ANSI/TIA-322, ANSI/ASSE A100.48 AND NESC STANDARDS.
11. GROUND AND INSULATE GUY WIRES IN ACCORDANCE WITH ROCKY MOUNTAIN POWER REQUIREMENTS AND NESC.
12. PROVIDE REQUIRED CLEARANCES FROM DISTRIBUTION LINES TO GUY WIRES PER ROCKY MOUNTAIN POWER AND NESC GUIDELINES.
13. FIELD VERIFY DIMENSIONS AND GUY ANCHORAGE POINTS PRIOR TO STARTING CONSTRUCTION.
14. INSTALL ANCHOR AS PER MANUFACTURER RECOMMENDATION TO ENSURE A MINIMUM CAPACITY OF AT LEAST 25,000 LBS.

DATE:	2-MAR-21
DRAWN BY:	MBD
CHECKED BY:	RDE
FILE:	SL01743A

REVISIONS		
DATE	DESCRIPTION	INITIAL

121 WEST ELECTION RD  
SUITE 330  
DRAPER, UT 84020  
801-816-4422  
FAX 801-816-4420

**RAGE DEVELOPMENT LLC**

801-972-6222

SITE NUMBER:  
**SL01743A**  
SITE NAME: RMP GLASSMAN WAY  
CITY, STATE: OGDEN, UT  
SHEET: GUY ANCHOR DETAILS

**S-3**

C:\Users\mdoney\Anderson\_Engineering Co., Inc\Structures - RAGE\SL01743A\_PROM\_RMP\_GLASSMAN WAY\2021\From\_Glassman\_Req.dwg