



Staff Report for Administrative Approval

Weber County Planning Division

Synopsis

Application Information

Application Request: Consideration and action on an alternative access request to use a private right-of-way as the primary access to a future one lot subdivision.

Agenda Date: Wednesday, January 20, 2021

Applicant: Mark & Karianne Banner (Owners)

File Number: AAE 2020-11

Property Information

Approximate Address: Old Snow Basin Rd. & Toliver Lane, Huntsville

Project Area: 5.568 acres

Zoning: Forest Valley 3 Zone (FV-3)

Existing Land Use: Vacant

Proposed Land Use: Residential

Parcel ID: 20-035-0030

Township, Range, Section: T6N, R1E, Section 23, SE

Adjacent Land Use

North: Vacant	South: Vacant
East: Vacant	West: Vacant

Staff Information

Report Presenter: Scott Perkes
 sperkes@webercountyutah.gov
 801-399-8772

Report Reviewer: RG

Applicable Land Use Codes

- Title 104 (Zones) Chapter 14 (Forest Valley 3 (FV-3) Zone)
- Title 108 (Standards) Chapter 7 (Supplementary and Qualifying Regulations) Section 29 (Flag lot access strip, private right-of-way, and access easement standards)
- Title 108 (Standards) Chapter 7 (Supplementary and Qualifying Regulations) Section 31 (Access to a lot/parcel using a private right-of-way or access easement)

Background

The applicant is requesting approval to use an existing 50-foot wide private access easement to provide access to a future one lot subdivision (see **Exhibits A and B**). The applicant currently owns 5.568 vacant acres located in the FV-3 zone (Parcel ID: 20-035-0030). This vacant land is set approximately 700' off of Old Snow Basin Road along the existing Toliver Lane. The applicant would like to subdivide the 5.568 acre parcel to create a buildable lot and use the existing Toliver Lane as primary access. Toliver Lane was created via warranty deed, Entry # 2737593 (see **Exhibit C**) and is currently being used as a private access easement (approved as file # AAE 2017-01) for the one-lot MWT Subdivision as recorded in August of 2018. See **Exhibit D** for the staff report associated with the approved access exemption AAE 2017-01. See **Exhibit E** for the engineered plans associated with Toliver Lane.

Analysis

The alternative access option was created as a means for landowners to provide access over, and across areas that restrict the construction of a standard County 66-foot right-of-way. Alternative access applications should be approved as long as the design standards can be implemented during the subdivision process, and the application meets the criteria in LUC §108-7-31(1)(c) which states:

Based on substantial evidence, it shall be shown that it is unfeasible or impractical to extend a street to serve such lot/parcel. Financial adversity shall not be considered; however, circumstances that may support an approval of a

private right-of-way/access easement as access to a lot/parcel may include but not be limited to unusual soil, topographic, or property boundary conditions.

Given the parcel's location within a mountain draw and its associated topography, in addition to the existing private lane, the applicant believes there to be "substantial evidence" that it would be impractical to extend a public road to serve this future subdivision. Additionally, there are portions of Toliver Lane that exceed a 10% grade. These grades were reviewed and approved by the Fire Marshal and County Engineer as part of File AAE 2017-1 (see **Exhibit D**).

Section 108-7-31 of the Land Use Code outlines the following condition that must be met as part of alternative access approval:

The landowner of record or authorized representative shall agree to pay a proportionate amount of the costs associated with developing a street if, at any time in the future, the county deems it necessary to have the landowner replace the private right-of-way/easement with a street that would serve as a required access to additional lots. The agreement shall be in the form considered appropriate and acceptable to the office of the Weber County Recorder and shall recite and explain all matters of fact, including a lot/parcel boundary description, which are necessary to make the agreement intelligible and show its successive nature.

The access easement must meet the design, safety, and parcel/lot standards outlined LUC §108-7-29(a) (b), and (c) prior to issuance of a certificate of occupancy on any home that will gain access from the access easement. The location of the access easement does not inhibit the creation of future roads, nor does it inhibit the continuation of existing roads in this area. In the future, if more lots are proposed to gain access by the proposed easement, a new alternative access application will be required, and the feasibility and practicality of a public road will be assessed.

Review Agencies: The Fire District has reviewed and conditionally approved this proposal, on the condition that the easement be constructed to the standards outlined in 108-7-29. Any other reviewing agency requirements will be conditions of approval.

Staff Recommendation

Staff recommends approval of AAE 2020-11, to provide access by private access easement to a future 1-lot subdivision. The recommendation for approval is subject to review agency requirements and the following conditions:

1. The access easement shall comply with the design, safety, and parcel/lot standards, as outlined in LUC §108-7-29.
2. The applicant shall agree to file the required alternative access covenant, as outlined in LUC §108-7-31, prior to the recording of the future subdivision.

Approval is based on the following findings:

1. The applicant has demonstrated that extending a fully improved road to 1 future lot is not practical due to the mountainous location and associated topography.

Administrative Approval

Administrative final approval of AAE 2020-11 to create a private access that would serve as an access to four future residential lots.

Date of Administrative Approval: _____

Rick Grover - Planning Director

Exhibits

- A. Alternative Access Exception Application
- B. Recorders Plat & Concept Plan
- C. Toliver Lane Warranty Deed
- D. AAE 2017-01 Staff Report
- E. Engineered Plans for Toliver Lane

Property Map



Weber County Alternative Access Application

Application submittals will be accepted by appointment only. (801) 399-8791, 2380 Washington Blvd. Suite 240, Ogden, UT 84401

Date Submitted /Completed 12/18/20	Application Fee: \$350.00	Receipt Number (Office Use)	File Number (Office Use)
--	-------------------------------------	-----------------------------	--------------------------

Application Type

- Flag lot access strip
- Access by Private Right of Way
- Access at a location other than across the front lot line

Property Owner Contact Information

Name of Property Owner(s) Mark + Karianne Banner		Mailing Address of Property Owner(s) 3688 W. Elk Valley Ln South Jordan, UT 84009	
Phone 385-237-6760	Fax		
Email Address (required) mbanner2@gmail.com		Preferred Method of Written Correspondence <input checked="" type="checkbox"/> Email <input type="checkbox"/> Fax <input type="checkbox"/> Mail	

Authorized Representative Contact Information

Name of Person Authorized to Represent the Property Owner(s)		Mailing Address of Authorized Person	
Phone	Fax		
Email Address (required)		Preferred Method of Written Correspondence <input type="checkbox"/> Email <input type="checkbox"/> Fax <input type="checkbox"/> Mail	

Property Information

Project Name Banner	Total Acreage 5.7 - 6.2	Current Zoning FV-3
Approximate Address Old Snow Basin Rd / Toliver Ln. ^{Huntsville} ^{UT} 84317	Land Serial Number(s) 20-035-0030	

Proposed Use
Primary Residence

Project Narrative
Take undeveloped lot and add: a

- primary residence
- Driveway
- Well
- Septic

~~Lot~~ Parcel to be accessed by Toliver Ln. A private road already deemed to meet Alternative Access Standards.

Basis for Issuance of Flag lot access strip

The land use authority shall determine whether or not it is feasible or desirable to extend a street to serve a parcel(s) or lot(s) at the current time, rather than approving a flag lot.

Sec. 108-7-30. - Flag lots

- (a) Criteria to be used in determining feasibility or desirability of extending a street shall include, but not be limited to topography, boundaries, and whether or not extending a road would open an area of five acres or more in Western Weber County and ten acres or more in the Ogden Valley for development.
- (b) The lot area exclusive of the access strip shall be a minimum of three acres.
- (c) Each lot shall access a street by means of its own fee title access strip. Successive stacking of lots on the same access strip is not permitted.
- (d) No access strip shall exceed 800 feet in length.
- (e) A maximum of two flag lot access strips may be located adjacent to each other.
- (f) No flag lot shall be allowed which proposes to re-subdivide or include within it (including the access strip) any portion of an existing lot in a recorded subdivision. No subdivision shall be vacated, re-subdivided, or changed in order to meet the requirements of this section.

Please provide information to support your request for a flag lot access strip outlining how the request meets the criteria listed above.

Basis for Issuance of Access by Private Right of Way

Lots/parcels which do not have frontage on a street, but which have access by a private right-of-way or access easement may, under certain circumstances, use a private right-of-way or access easement as the primary access. Approval is subject to the applicant demonstrating compliance with the following criteria and conditions:

Sec. 108-7-31. - Access to a lot/parcel using a private right-of-way or access easement:

Criteria.

- a. The lot/parcel is a bona fide agricultural parcel that is actively devoted to an agricultural use that is the main use; or
- b. The lot/parcel is a bona fide agricultural parcel that is actively devoted to an agricultural use that is the main use and is the subject parcel of an approved agri-tourism operation; or
- c. Based on substantial evidence, it shall be shown that it is unfeasible or impractical to extend a street to serve such lot/parcel. Financial adversity shall not be considered; however, circumstances that may support an approval of a private right-of-way/access easement as access to a lot/parcel may include but not be limited to unusual soil, topographic, or property boundary conditions.

Conditions.

- a. It shall be demonstrated that the agricultural parcel or other lot/parcel has appropriate and legal access due to historic use, court decree, or the execution of an easement, right-of-way, or other instrument capable of conveying or granting such right; and
- b. The landowner of record or authorized representative shall agree to pay a proportionate amount of the costs associated with developing a street if, at any time in the future, the county deems it necessary to have the landowner replace the private right-of-way/easement with a street that would serve as a required access to additional lots. The agreement shall be in the form considered appropriate and acceptable to the office of the Weber County Recorder and shall recite and explain all matters of fact, including a lot/parcel boundary description, which are necessary to make the agreement intelligible and show its successive nature.

Please provide the following information to support your request for access to a lot/parcel using a private right-of-way or access easement:

- Attach proof to this application that the agricultural parcel or other lot/parcel has appropriate and legal access due to historic use, court decree, or the execution of an easement, right-of-way, or other instrument capable of conveying or granting such right.
- The landowner of record or authorized representative agrees to pay a proportionate amount of the costs associated with developing a street if, at any time in the future, the County deems it necessary to have the landowner replace the private right-of-way/easement with a street that would serve as a required access to additional lots. The agreement shall be in the form considered appropriate and acceptable to the office of the Weber County Recorder and shall recite and explain all matters of fact, including a lot/parcel boundary description, which are necessary to make the agreement intelligible and show its successive nature.

Basis for Issuance of Access to a lot/parcel at a location other than across the front lot line

Access to lots/parcels at a location other than across the front lot line may be approved as the primary access, subject to the following criteria:

Sec. 108-7-32. - Access to a lot/parcel at a location other than across the front lot line.

(1) The applicant demonstrates that special or unique boundary, topographic, or other physical conditions exist which would cause an undesirable or dangerous condition to be created for property access across the front lot line.

(2) It shall be demonstrated that appropriate and legal access exists due to historic use, court decree, or the execution of an easement, right-of-way, or other instrument capable of conveying or granting such right.

Please provide the following information to support your request for Access to a lot/parcel at a location other than across the front lot line:

- Attach proof that appropriate and legal access exists due to historic use, court decree, or the execution of an easement, right-of-way, or other instrument capable of conveying or granting such right.
- The landowner of record or authorized representative agrees to pay a proportionate amount of the costs associated with developing a street if, at any time in the future, the County deems it necessary to have the landowner replace the private right-of-way/easement with a street that would serve as a required access to additional lots. The agreement shall be in the form considered appropriate and acceptable to the office of the Weber County Recorder and shall recite and explain all matters of fact, including a lot/parcel boundary description, which are necessary to make the agreement intelligible and show its successive nature.

Property Owner Affidavit

I (We), Mark & Karianne, depose and say that I (we) am (are) the owner(s) of the property identified in this application and that the statements herein contained, the information provided in the attached plans and other exhibits are in all respects true and correct to the best of my (our) knowledge. I (We) understand that an approval of an alternative access application does not grant a legal right to access property that I(we) currently do not own.

Mark B Property Owner Karianne Property Owner

Subscribed and sworn to me this 18 day of December, 2020.

Rodolfo Rivera Notary

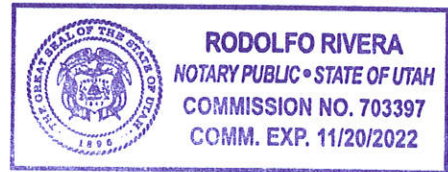

Authorized Representative Affidavit

I (We), _____, the owner(s) of the real property described in the attached application, do authorized as my (our) representative(s), _____, to represent me (us) regarding the attached application and to appear on my (our) behalf before any administrative or legislative body in the County considering this application and to act in all respects as our agent in matters pertaining to the attached application.

_____ Property Owner _____ Property Owner

Dated this ____ day of _____, 20 __, personally appeared before me _____, the signer(s) of the Representative Authorization Affidavit who duly acknowledged to me that they executed the same.

_____ Notary

S.E. 1/4
SECTION 23, T.6N., R.1E., S.L.B. & M.

HUNTSVILLE DISTRICT

SCALE 1"=200'

TAXING UNIT: 520

SEE PAGE 35

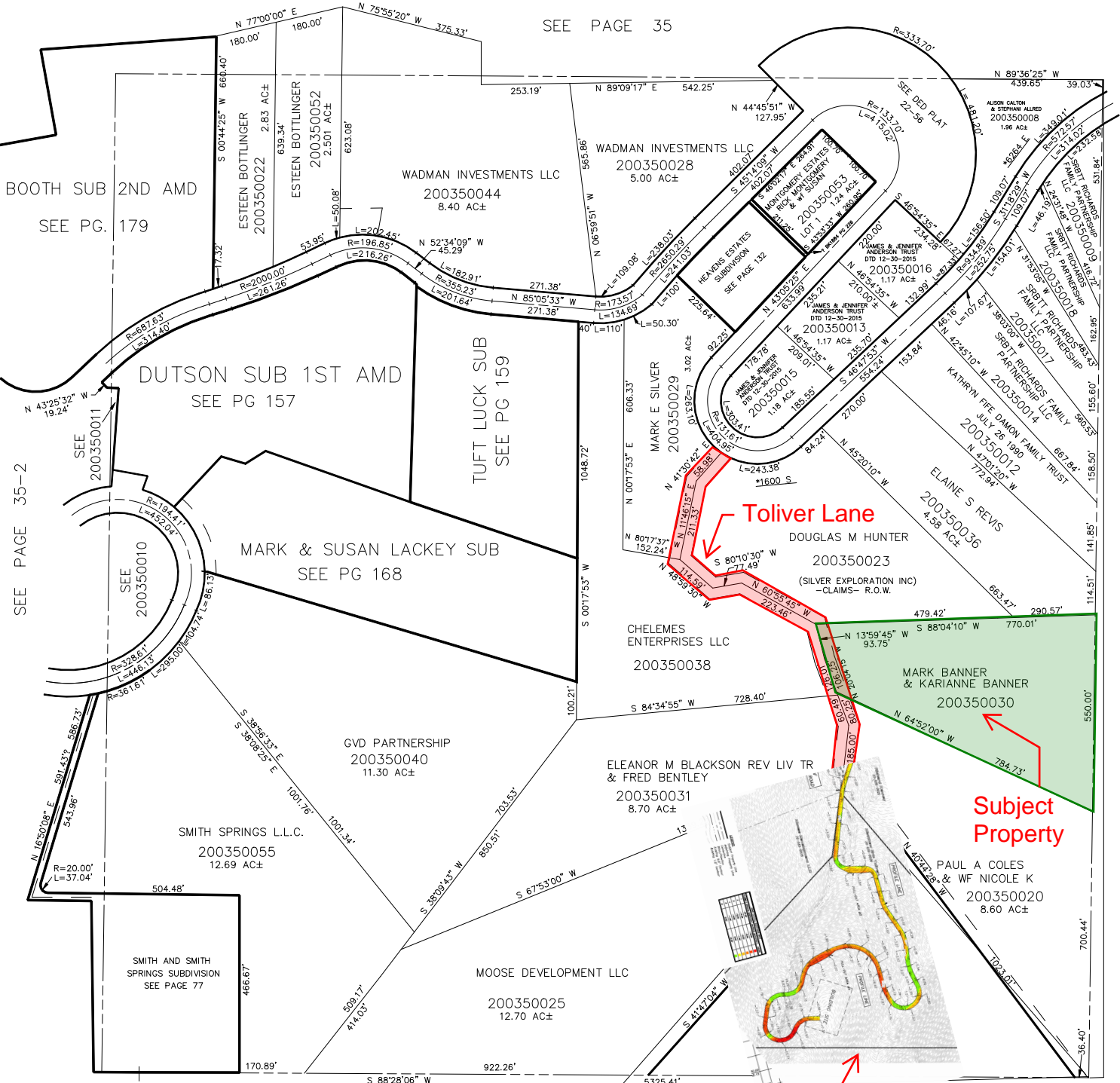

SEE PAGE 35-2

SEE PAGE 36

MWT Subdivision & Continuation of Toliver Lane (2018)



W2737593

Recording Requested by:
First American Title Company, LLC
585 West 500 South, Suite 100
Bountiful, UT 84010
(801)298-2400

E# 2737593 PG 1 OF 2
Leann H. Kilts, WEBER COUNTY RECORDER
27-May-15 11:04 AM FEE \$13.00 DEP SY
REC FOR: FIRST AMERICAN - BOUNTIFUL
ELECTRONICALLY RECORDED

AFTER RECORDING RETURN TO:
Matthew Eric Toliver
4960 East 2775 North
Eden, UT 84310

SPACE ABOVE THIS LINE (3 1/2" X 5") FOR RECORDER'S USE

SPECIAL WARRANTY DEED

Escrow No: 331-5711847 (ER)
A.P.N.: 20-035-0039 *SPM* CM

GAF Investments LLC, Grantor, of **Ogden**, **Weber** County, State of **Utah**, hereby CONVEYS AND WARRANTS only as against all claiming by, through or under it to

Matthew Eric Toliver, Grantee, of **Huntsville**, **Weber** County, State of **UT**, for the sum of Ten Dollars and other good and valuable considerations the following described tract(s) of land in **Weber** County, State of **Utah**:

PART OF THE SOUTHEAST QUARTER OF SECTION 23, TOWNSHIP 6 NORTH, RANGE 1 EAST, SALT LAKE BASE AND MERIDIAN, U.S. SURVEY: BEGINNING AT A POINT 2628.99 FEET SOUTH ALONG THE SECTION LINE AND 36.40 FEET SOUTH 88°28'06" WEST FROM THE EAST QUARTER CORNER OF SAID SECTION; RUNNING THENCE SOUTH 88°28'06" WEST 1238.26 FEET, NORTH 41°47'04" EAST 821.25 FEET, NORTH 6°37' EAST 197.59 FEET; THENCE SOUTH 40°43'54" EAST 1023.46 FEET TO THE POINT OF BEGINNING.

ALSO A 50 FOOT RIGHT OF WAY ACROSS A PART OF THE SOUTHEAST QUARTER OF SECTION 23, TOWNSHIP 6 NORTH, RANGE 1 EAST, SALT LAKE BASE & MERIDIAN, U.S. SURVEY: SAID RIGHT OF WAY BEING 25 FEET ON EITHER SIDE OF AND PARALLEL TO THE FOLLOWING DESCRIBED ROAD CENTER LINE: BEGINNING AT A POINT WHICH IS SOUTH 2628.99 FEET ALONG THE EAST SECTION LINE, SOUTH 88°28'06" WEST 36.40 FEET ALONG THE SOUTH SECTION LINE AND NORTH 40°43'54" WEST 1023.46 FEET FROM THE EAST QUARTER CORNER OF SAID SECTION 23, RUNNING THENCE NORTH 6°37' EAST 185.00 FEET, THENCE NORTH 20°04'15" WEST 186.50 FEET, THENCE NORTH 13°59'45" WEST 93.75 FEET, THENCE NORTH 60°55'45" WEST 223.46 FEET, THENCE SOUTH 80°10'30" WEST 77.49 FEET, NORTH 48°59'30" WEST 114.59 FEET, THENCE NORTH 11°46'15" EAST 211.33 FEET, THENCE NORTH 41°30'42" EAST 58.98 FEET TO THE SOUTH LINE OF THE SNOW BASIN ROAD.

Subject to easements, restrictions and rights of way appearing of record or enforceable in law and equity and general property taxes for the year 2014 and thereafter.

Exhibit C

Witness, the hand(s) of said Grantor(s), this **May 26, 2015** .

GAF Investments LLC



By: Greg Furch, Managing Member

STATE OF Utah)
County of Wasatch)ss.

On May 26, 2015 before me, the undersigned Notary Public, personally appeared **Greg Furch, Managing Member of GAF Investments LLC**, personally known to me (or proved to me on the basis of satisfactory evidence) to be the person(s) whose name(s) is/are subscribed to the within instrument and acknowledged to me that he/she/they executed the same in his/her/their authorized capacity(ies) and that his/her/their signature(s) on the instrument the person(s) or the entity upon behalf of which the person(s) acted, executed the instrument.

WITNESS my hand and official seal.

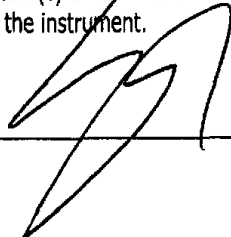
My Commission Expires: 12/7/18

Notary Public

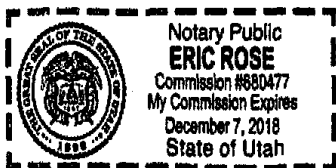



Staff Report to the Weber County Planning Division

Weber County Planning Division

Synopsis

Application Information

Application Request: Consideration and action on a request for an approval of an alternative access by private right of way to access a parcel that is located at approximately 6045 East Old Snowbasin Road.

Agenda Date: Wednesday, March 08, 2017

Applicant: Matthew Eric Toliver, owner

File Number: AAE 2017-01

Property Information

Approximate Address: 6045 East Old Snowbasin Road

Project Area: 10.20 Acres

Zoning: Forest Valley 3 (FV-3)

Existing Land Use: Vacant

Proposed Land Use: Residential

Parcel ID: 20-035-0039

Township, Range, Section: T6N, R1E, Sections 23

Adjacent Land Use

North: Forest	South: Forest
East: Residential	West: Forest

Staff Information

Report Presenter: Felix Lleverino
 flleverino@co.weber.ut.us
 801-399-8767

Report Reviewer: SM

Applicable Land Use Codes

- Title 104 (Zones) Chapter 14 (Forest Valley Zone, FV-3)
- Title 104 (Zones) Chapter 28 (Ogden Valley Sensitive Lands Overlay District)
- Title 108 (Standards) Chapter 7 (Supplementary and Qualifying Regulations)
- Title 108 (Standards) Chapter 22 (Natural Hazard Areas)

Background and Summary

The applicant is requesting approval to use a 50 foot private right-of-way as the primary access to a future one lot subdivision on a 10.20 acre parcel. The applicant would like to improve an existing dirt road by bringing it up to County Standards and widening it to a 12 foot travel surface. The length of the proposed access road will be approximately 1,166 feet. The property is located in the Forest Valley FV-3 Zone at approximately 6045 East Old Snowbasin Road. See Exhibit A for application. Construction drawings for the private right of way have been included in this report as Exhibits B.

As part of the approval process, the proposal has been reviewed against the current Weber County Land Use Code (LUC), and the standards of the FV-3 zone found in LUC §104-14, and the criteria for an access to a lot/parcel using a private right-of-way or access easement found in LUC §108-7-31.

Analysis

General Plan: This Alternative Access by private right of way is in harmony with the Ogden Valley General Plan. An alternative access at the width of 12 feet has reduced negative impacts to the surroundings.

Zoning: The property is located in the FV-3 Zone. The purpose of this zone is stated in the LUC §104-14-1.

“The purpose of the Forest Valley Zone, FV-3 is to provide area for residential development in a forest setting at a low density, as well as to protect as much as possible the naturalistic environment of the development.”

Alternative Access Criteria: This proposal has also been reviewed to determine if it meets the criteria stated in LUC §108-7-31(c), which states the it in order to approve an alternative access application it shall be shown that it is impractical to extend a public street to serve the parcel/lot due to any of the following conditions: unusual soil, topographic conditions, or property boundary conditions. This application meets those criteria based on: the mountainous terrain, the soil conditions, the right-of-way will cross at least two ephemeral streams, and that this parcel does not have access on a public road.

Natural Hazards: Much of this area is located within a Geologic Study Area. At the time of subdivision application, a geologic reconnaissance study is required. This requirement is supported by LUC §108-22-3 (Studies and Reports Required).

Sensitive Lands: There are two natural ephemeral streams that will be crossed during the construction of this private access road. A Stream Alteration permit will have to be obtained from the Division of Drinking Water prior to construction. Bridges and stream alterations, approved by the Army Corps of Engineers are allowed within a stream corridor LUC §104-28-2 (b)(2)(a).

Private Right of Way Access: In order to provide for safe and consistent year round access there are specific design and road construction standards that shall be met and they are as follows:

1. The private right of way shall be designed and built to a standard approved by the County Engineer.
2. The minimum width of the travel surface is 12 feet wide if the access is serving less than five dwellings.
3. The improved surface shall be capable of supporting a minimum weight of 75,000 pounds.
4. This access road is greater than 800 feet; therefore, turnouts shall be place at least every 400 feet. Turnouts are shown on the road construction plans which are required to be a minimum of ten feet wide and 40 feet in length.
5. The LUC states that a private right of way shall have a maximum grade of 10 percent; However, Weber County Fire Department and the County Engineer have approved that the maximum grade shall not exceed 15 percent.
6. The flag private right-of-way shall have a minimum vertical clearance of 14.5 feet.
7. No buildings structures or parking areas are allowed within the private right-of-way.
8. There will be several culverts placed where the road crosses the stream. The culverts must be capable of supporting 75,000 pounds.

Access Easement: The applicant will be utilizing an established 50 foot access easement that was recorded in the Weber County Recorder's Office on May 27, 2015. See Exhibit E for the Special Warranty Deed.

Safety Standards:

1. The lot address shall be placed in a prominently visible location at the entrance to the private right of way.
2. Turn outs measuring 10 feet by 40 feet shall be provided adjacent to the travel surface of the private right-of-way, and placed at least every 400 feet.
3. "A turn-around area shall be provided at the home location to allow firefighting equipment to turn around. This area shall be a year round surface capable of supporting fire equipment (a minimum inside turning radius of 30 feet and an outside turning radius of not less than 45 feet)."

Review Agencies: The Weber County Fire District and Weber County Engineering Department have approved the road construction plans, while making it clear that there will be additional requirements with regard to fire suppression measures, and private maintenance. See Exhibit C for Weber County Fire District's review.

Public Notice: Noticing was provided to all property owners of record within 500 feet of the subject property.

Staff Recommendation

Staff recommends approval of the Matt Toliver Alternative Access for a future one lot subdivision. This recommendation for approval is subject to all applicable review agency requirements and is based on the following conditions:

1. A Stream Alteration permit must be obtained from the Division of Drinking Water prior to construction.
2. The lot address shall be placed in a prominently visible location at the entrance to the private right of way.
3. Turn outs measuring 10 feet by 40 feet shall be shown on the construction drawings
4. The improvements shall be constructed prior to issuance of a Land Use permit and Building Permit.
5. On the road construction drawings, show a turn around that meets County Safety Standards.

This recommendation is based on the following findings:

1. It is not practical to extend or construct a public right-of-way due to surrounding topography, soil conditions, and property boundary conditions.
2. The proposed alternative access conforms to the Ogden Valley General Plan.
3. The proposed alternative access complies with the applicable County ordinances.

Administrative Approval

Administrative final approval of Matt Toliver Alternative Access is hereby granted based upon its compliance with the Weber County Land Use Code. This approval is subject to the requirements of applicable review agencies and the conditions of approval listed in this staff report.

Date of Administrative Approval: 3/8/17



Rick Grover
Weber County Planning Director

Exhibits

- A. Application with Narrative
- B. Private Right of Way Construction Drawings
- C. Weber County Fire District's Review
- D. Current Recorder's Plat
- E. Special Warranty Deed

Area Map

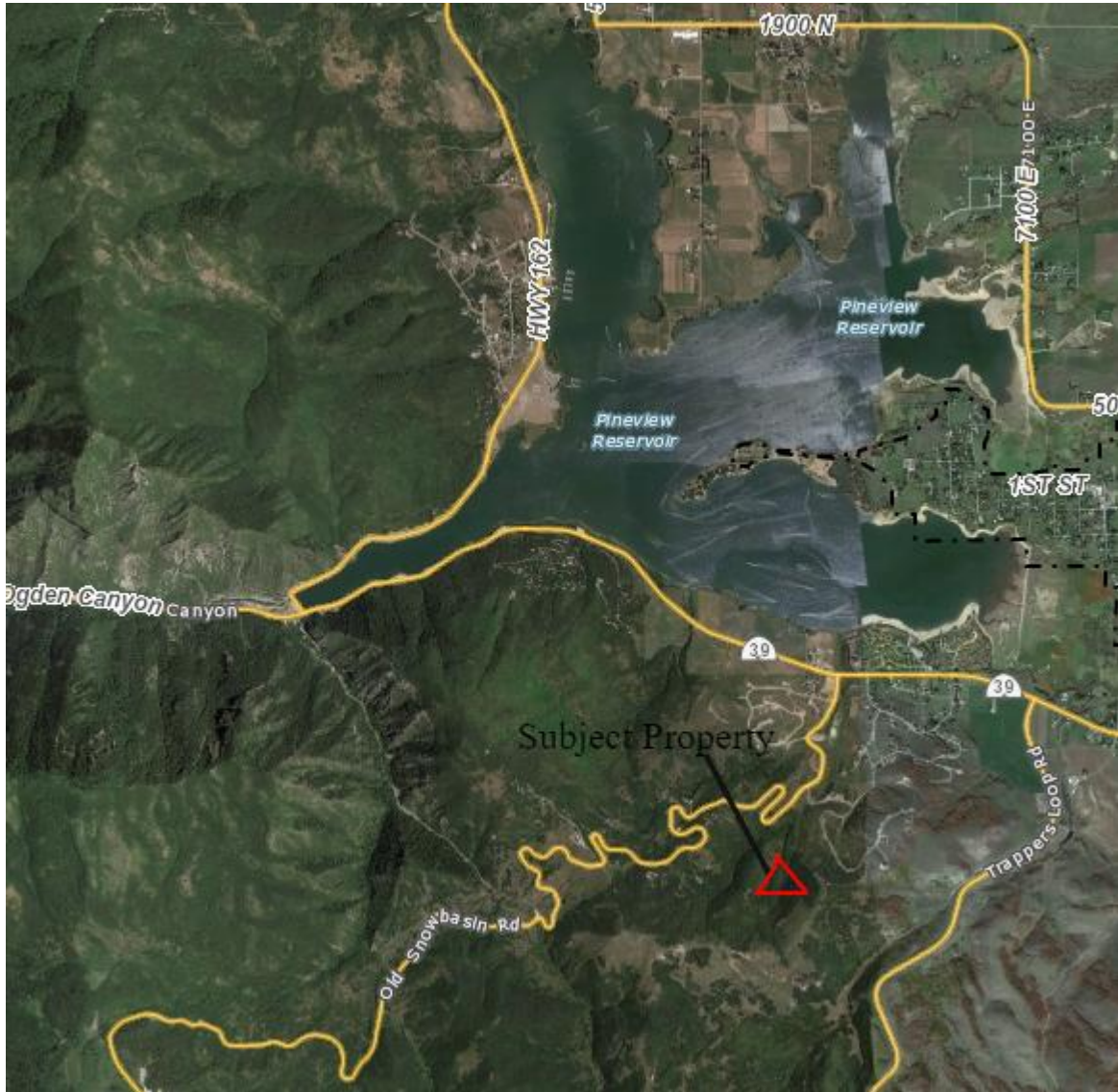

Weber County Alternative Access Application			
Application submittals will be accepted by appointment only. (801) 399-8791, 2380 Washington Blvd. Suite 240, Ogden, UT 84401			
Date Submitted /Completed	Application Fee: \$225.00	Receipt Number (Office Use)	File Number (Office Use)
Application Type			
<input type="checkbox"/> Flag lot access strip <input type="checkbox"/> Access by Private Right of Way <input checked="" type="checkbox"/> Access at a location other than across the front lot line			
Property Owner Contact Information			
Name of Property Owner(s) Matthew Eric Toliver		Mailing Address of Property Owner(s) 4960 E. 2775 N. Eden UT 84310	
Phone 801-430-1024	Fax 801-394-9219	Preferred Method of Written Correspondence <input checked="" type="checkbox"/> Email <input type="checkbox"/> Fax <input type="checkbox"/> Mail	
Email Address (required) toliver23@aol.com			
Authorized Representative Contact Information			
Name of Person Authorized to Represent the Property Owner(s) Matthew E. Toliver		Mailing Address of Authorized Person Same as above	
Phone same as above	Fax	Preferred Method of Written Correspondence <input checked="" type="checkbox"/> Email <input type="checkbox"/> Fax <input type="checkbox"/> Mail	
Email Address (required)			
Property Information			
Project Name Single lot Subdivision		Total Acreage 10.00 acres	Current Zoning FU-3
Approximate Address 5800 old snow basin Road Huntsville 84317		Land Serial Number(s) 20-035-0039	
Proposed Use I would like to access a single lot subdivision			
Project Narrative I'm trying to begin the process to get my lot approved as a single lot subdivision. I would like to bring the access road in on the 50' easement that the property has off of old snowbasin road.			

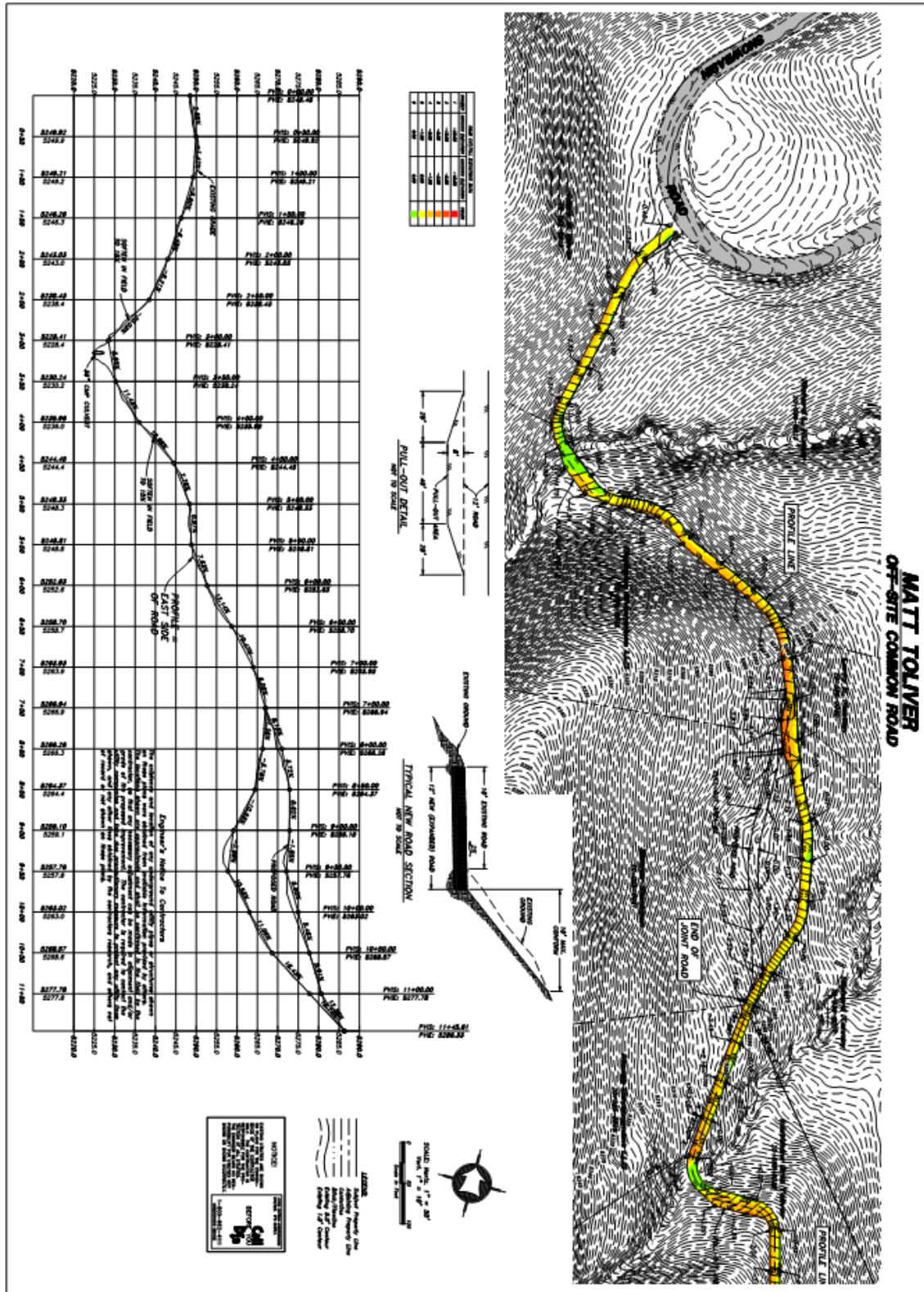

Date: February 4, 2017

Project Name: Toliver Alternative Access

Project Address: 5300 Old Snowbasin Road Huntsville 84317

Contractor/Contact: Matthew Toliver toliver73@aol.com 801-430-1024

Fees: See attached PDF

FEE NOTICE:

Weber Fire District has various fees associated with plan reviews, and inspections. Please be prepared to make payments at the time of inspections or when you pick up your approved plans. Impact Fees are due prior to taking out a building permit. Make checks payable to: **Weber Fire District**.

REVIEW STATUS: APPROVED WITH CONDITIONS

SPECIFIC COMMENTS:

1. The access drawings indicating the roadway (driveway to home) were submitted. The road appears to meet the requirements of the county ordinance and fire code. There are sections of the roadway in which the grade exceeds 10%. The engineer had met with me previously concerning this and the request to exceed the 10% grade in the limit areas indicated on the drawings is approved.
2. Due to the allowance of the grade greater than 10%, and the home being in the Wildland Urban Interface area, the home shall be provided with a fire suppression system as allowed to be required by Utah State law.
3. The property location and structure is within the Wildland Urban Interface and is therefore subject to the requirements of the 2006 Utah Wildland-Urban Interface Code. Provide the following documentation:
 - Completed "Fire Hazard Severity Form" (Appendix C).
 - Statement of conformance signed by the architect.
 - Any applicable alterations to comply the WUI code.
1. All roads shall be designed, constructed, surfaced and maintained so as to provide an all-weather driving surface.
2. Fire access roads for this project shall be completed and approved prior to any combustible construction. Temporary roads shall meet the same requirements for height, width and imposed loads as permanent roads.
3. All required fire hydrants and water systems shall be installed, approved and fully functional prior to any combustible construction.
4. If the building is equipped with an fire suppression system, there shall be a weather proof horn/strobe device located on the street side of the building as approved by the Fire Prevention Division (coordinate with fire inspector regarding location).

Every effort has been made to provide a complete and thorough review of these plans. This review does not relieve the owner, contractor and/or developer from compliance with any and all applicable codes and standards. Any change or revision of this plan will render this review void and will require submittal of the new or revised layout for fire department review.

Reviewed by: Brandon Thueson

Fire Marshal

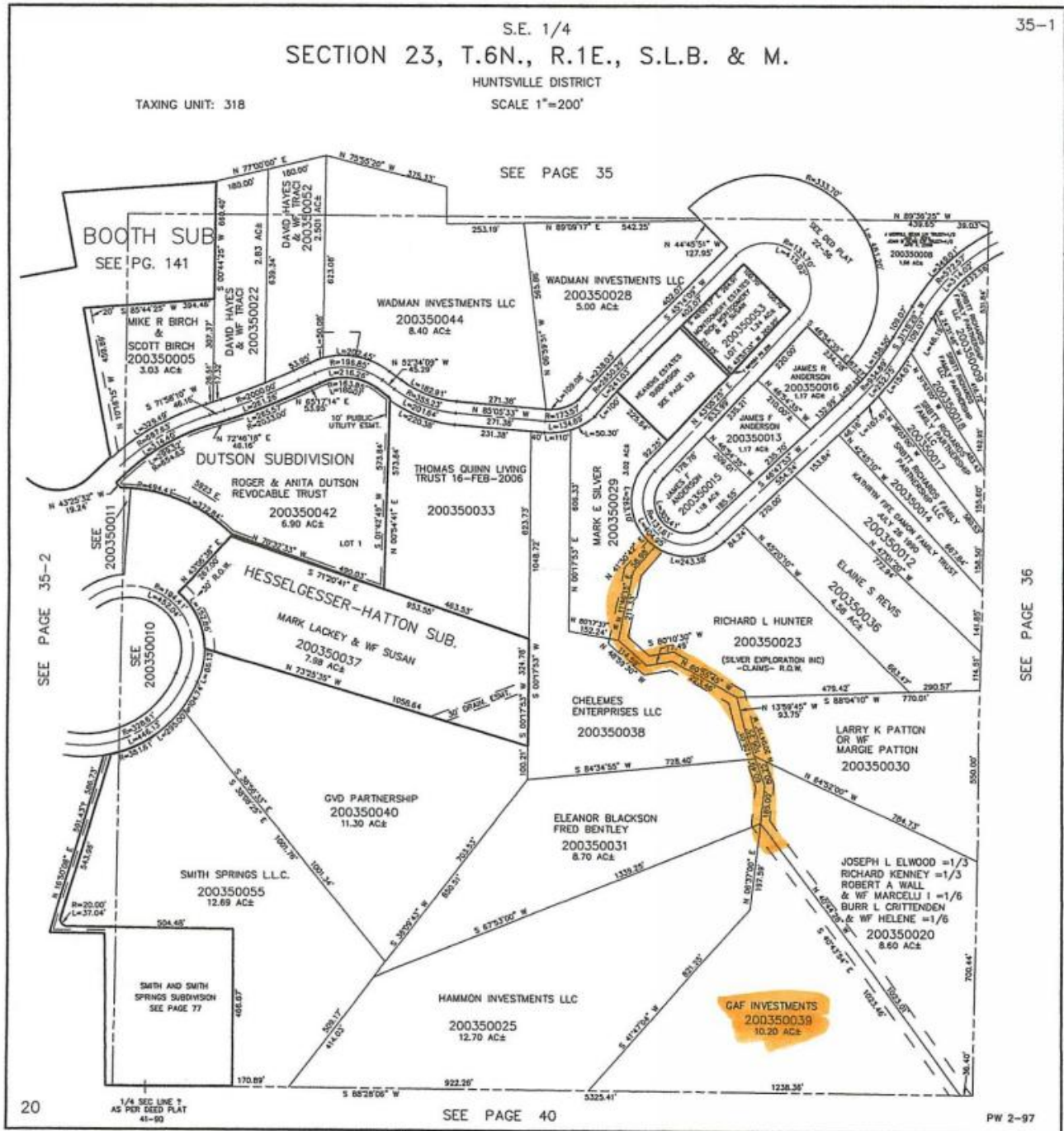



W2737593

Recording Requested by:
 First American Title Company, LLC
 585 West 500 South, Suite 100
 Bountiful, UT 84010
 (801)298-2400

E# 2737593 PG 1 OF 2
 Leann H. Kilts, WEBER COUNTY RECORDER
 27-May-15 11:04 AM FEE \$13.00 DEP SY
 REC FOR: FIRST AMERICAN - BOUNTIFUL
 ELECTRONICALLY RECORDED

AFTER RECORDING RETURN TO:
 Matthew Eric Toliver
 4960 East 2775 North
 Eden, UT 84310

SPACE ABOVE THIS LINE (3 1/4" X 5") FOR RECORDER'S USE

SPECIAL WARRANTY DEED

Escrow No: **331-5711847 (ER)**
 A.P.N.: **20-035-0039**

GAF Investments LLC, Grantor, of **Ogden**, **Weber County**, State of **Utah**, hereby CONVEYS AND WARRANTS only as against all claiming by, through or under it to

Matthew Eric Toliver, Grantee, of **Huntsville**, **Weber County**, State of **UT**, for the sum of Ten Dollars and other good and valuable considerations the following described tract(s) of land in **Weber County**, State of **Utah**:

PART OF THE SOUTHEAST QUARTER OF SECTION 23, TOWNSHIP 6 NORTH, RANGE 1 EAST, SALT LAKE BASE AND MERIDIAN, U.S. SURVEY: BEGINNING AT A POINT 2628.99 FEET SOUTH ALONG THE SECTION LINE AND 36.40 FEET SOUTH 88°28'06" WEST FROM THE EAST QUARTER CORNER OF SAID SECTION; RUNNING THENCE SOUTH 88°28'06" WEST 1238.26 FEET, NORTH 41°47'04" EAST 821.25 FEET, NORTH 6°37' EAST 197.59 FEET; THENCE SOUTH 40°43'54" EAST 1023.46 FEET TO THE POINT OF BEGINNING.

ALSO A 50 FOOT RIGHT OF WAY ACROSS A PART OF THE SOUTHEAST QUARTER OF SECTION 23, TOWNSHIP 6 NORTH, RANGE 1 EAST, SALT LAKE BASE & MERIDIAN, U.S. SURVEY: SAID RIGHT OF WAY BEING 25 FEET ON EITHER SIDE OF AND PARALLEL TO THE FOLLOWING DESCRIBED ROAD CENTER LINE: BEGINNING AT A POINT WHICH IS SOUTH 2628.99 FEET ALONG THE EAST SECTION LINE, SOUTH 88°28'06" WEST 36.40 FEET ALONG THE SOUTH SECTION LINE AND NORTH 40°43'54" WEST 1023.46 FEET FROM THE EAST QUARTER CORNER OF SAID SECTION 23, RUNNING THENCE NORTH 6°37' EAST 185.00 FEET, THENCE NORTH 20°04'15" WEST 186.50 FEET, THENCE NORTH 13°59'45" WEST 93.75 FEET, THENCE NORTH 60°55'45" WEST 223.46 FEET, THENCE SOUTH 80°10'30" WEST 77.49 FEET, NORTH 48°59'30" WEST 114.59 FEET, THENCE NORTH 11°46'15" EAST 211.33 FEET, THENCE NORTH 41°30'42" EAST 58.98 FEET TO THE SOUTH LINE OF THE SNOW BASIN ROAD.

Subject to easements, restrictions and rights of way appearing of record or enforceable in law and equity and general property taxes for the year **2014** and thereafter.

MATT TOLIVER OFF-SITE COMMON ROAD

Exhibit E

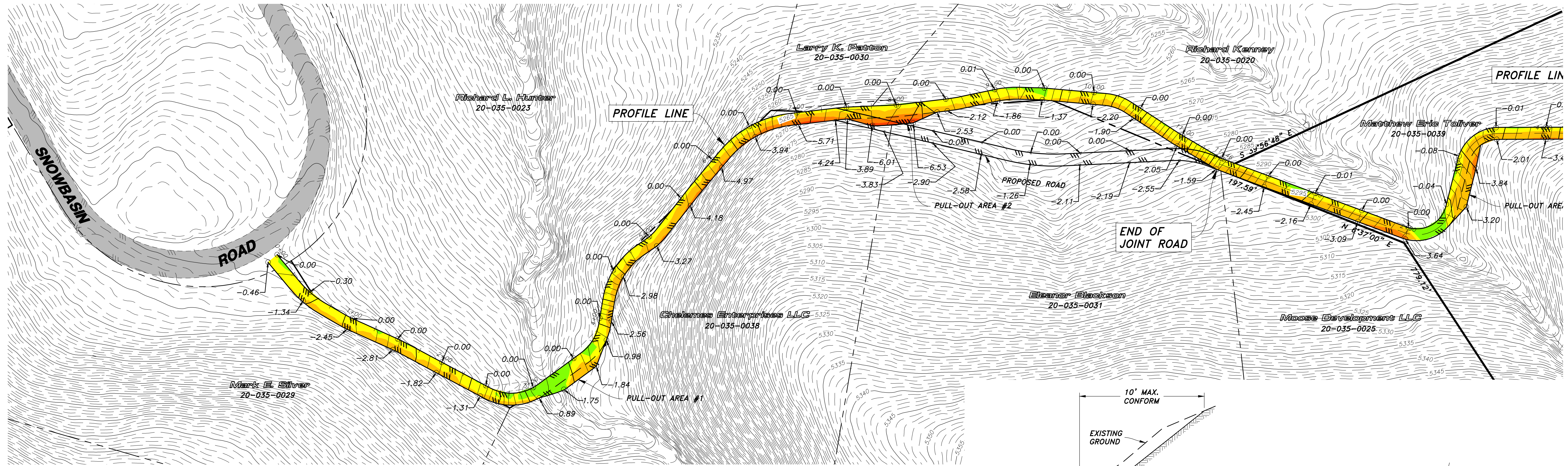

ROAD CUT/PULL ELEVATIONS DATA			
NUMBER	MINIMUM ELEVATION	MAXIMUM ELEVATION	COLOR
1	-20.00	-10.00	Red
2	-10.00	-5.00	Orange
3	-5.00	-3.00	Yellow
4	-3.00	-1.00	Light Green
5	-1.00	0.00	Green
6	0.00	6.00	Light Green

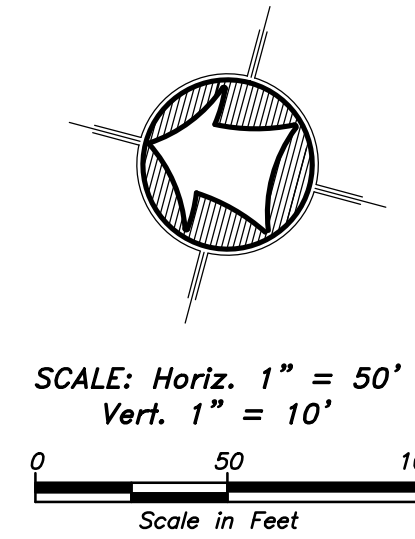
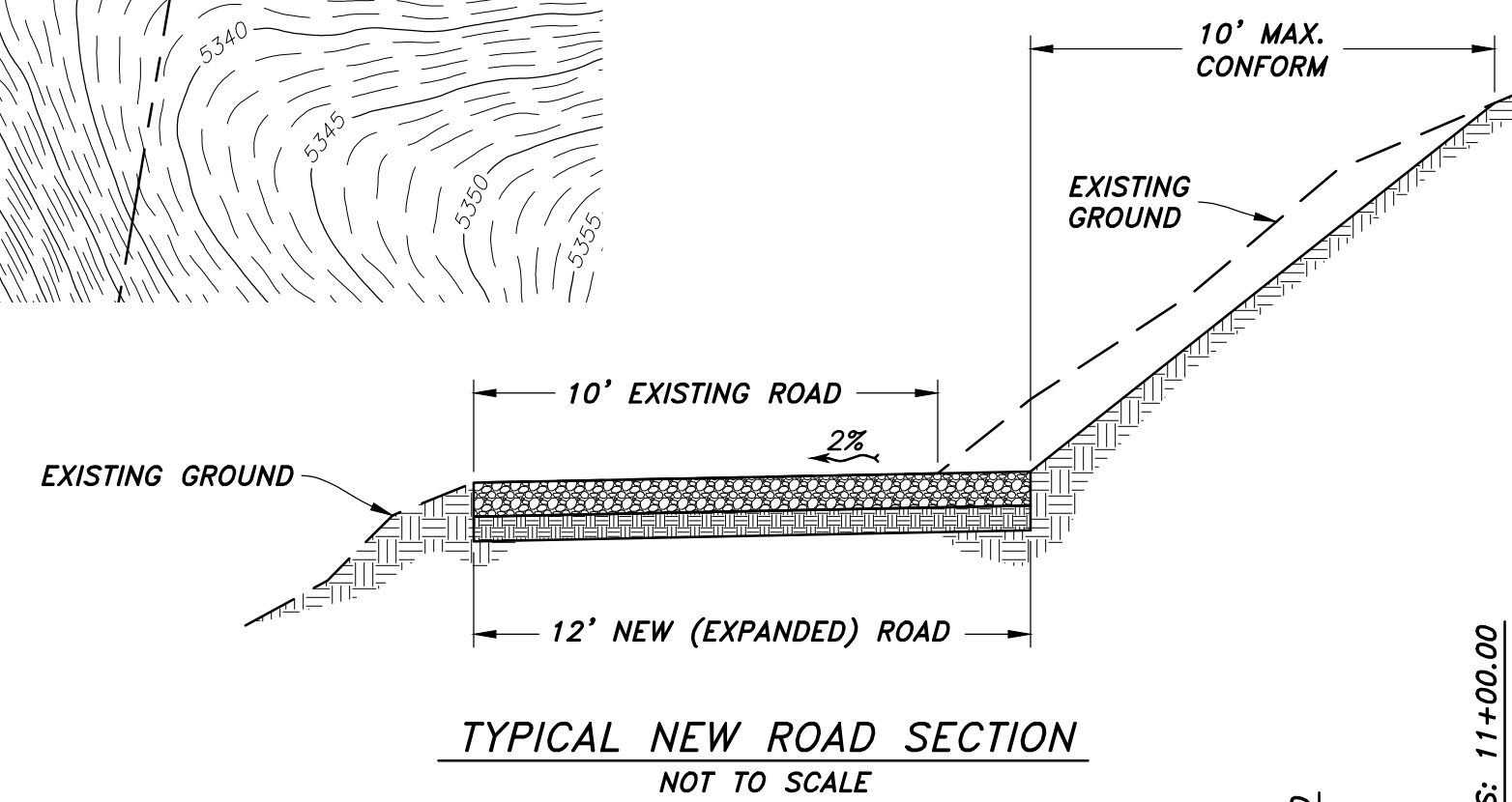
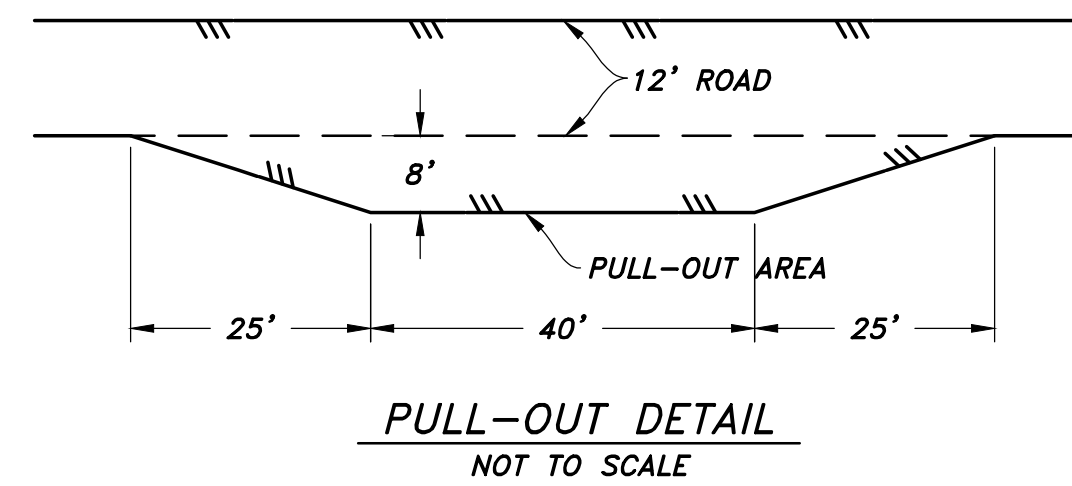

- LEGEND**
- Subject Property Line
 - Adjoining Property Line
 - Centerline
 - Ditch/Flowline
 - Existing 5.0' Contour
 - Existing 1.0' Contour

NOTICE!

EXISTING UTILITIES ARE SHOWN ON PLANS FOR THE CONVENIENCE OF THE CONTRACTOR ONLY. THE CONTRACTOR IS RESPONSIBLE FOR THE PROTECTION OF ALL UTILITIES. THE ENGINEER BEARS NO RESPONSIBILITY FOR UTILITIES NOT SHOWN OR SHOWN INCORRECTLY.

Call Digs BEFORE YOU UNDERGROUPE

1-800-662-4111
UNDERGROUND SERVICE

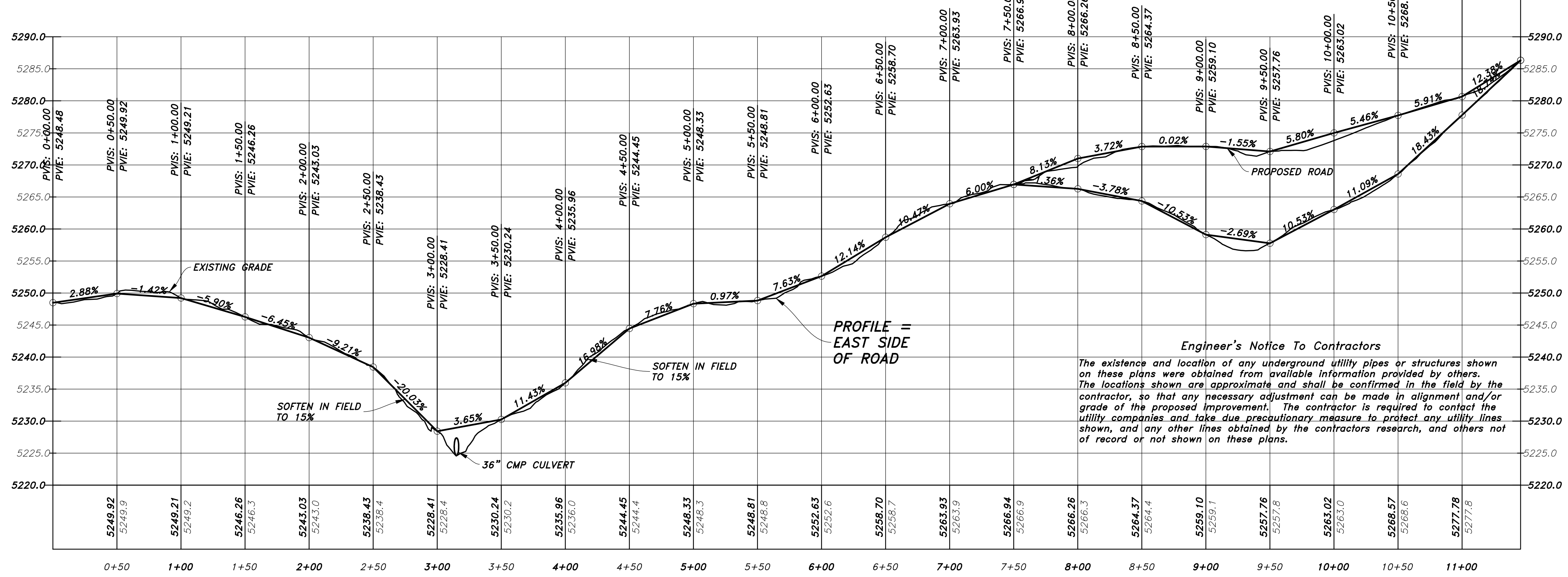

HANSEN & ASSOCIATES, INC.
Consulting Engineers and Land Surveyors
538 North Main Street, Brigham, Utah 84302
Visit us at www.hansen.net
Brigham City, Utah
(435) 723-3491 (801) 399-4905 (435) 752-8272



Drawn By: MTH Date: 12/13/16
Designed By: _____
Checked By: _____
Approved By: _____
Scale: 1" = 50'
Drawing File: 15-12415pp.DWG
JOB NUMBER: 15-124

PLAN AND PROFILE FOR
MATT TOLIVER
ADDRESS
HUNTSVILLE DISTRICT
A Part of the Southeast Quarter of Section 23
Township 6 North, Range 1 East, S.L.B.&M.

Sheet
1
of
2
Sheets

MATT TOLIVER ON-SITE PRIVATE DRIVEWAY

Exhibit E

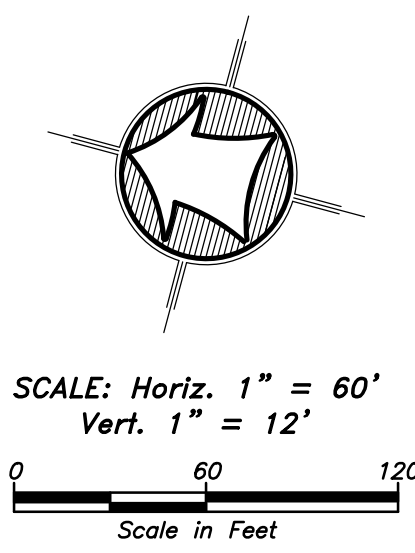
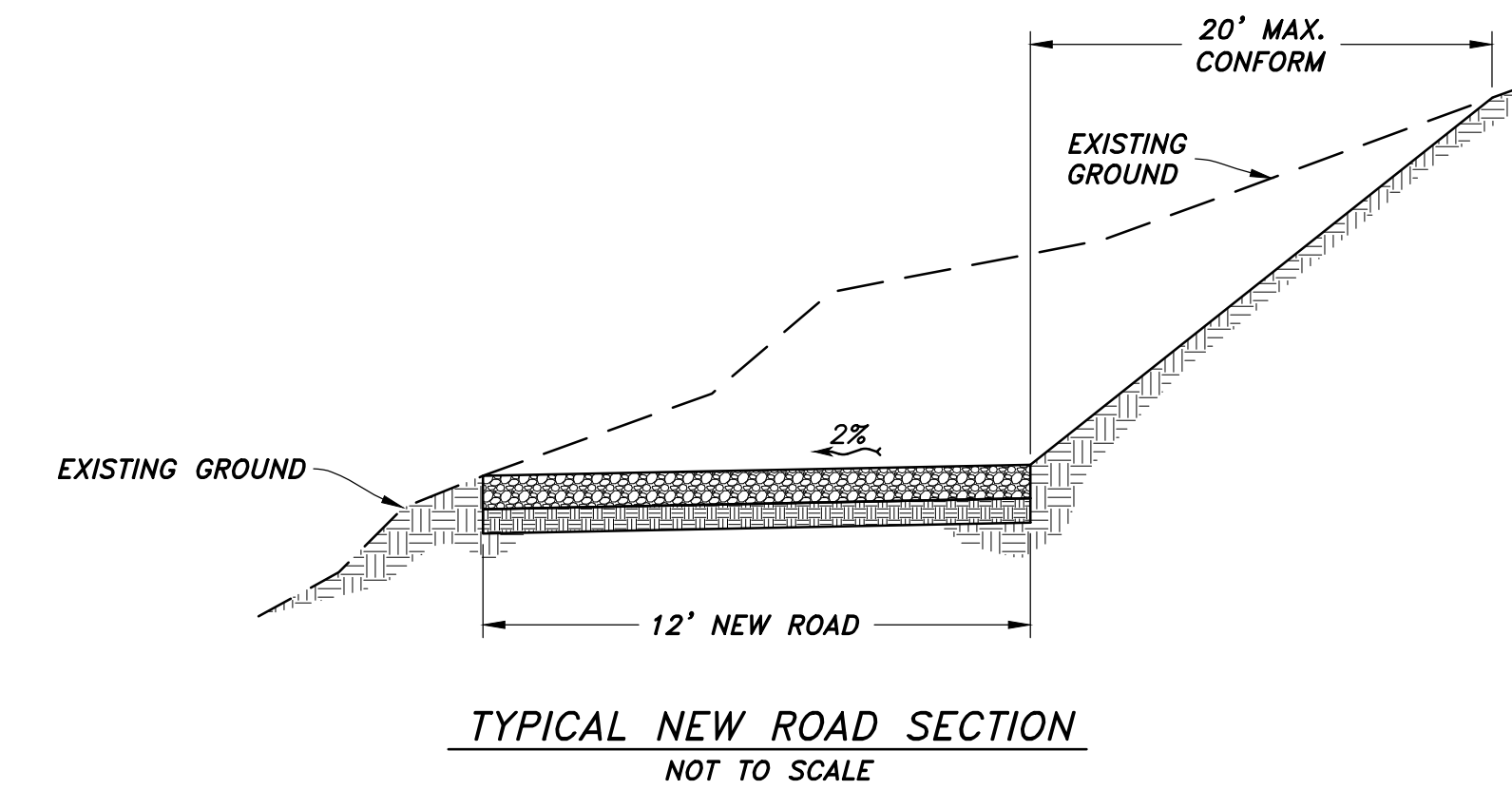
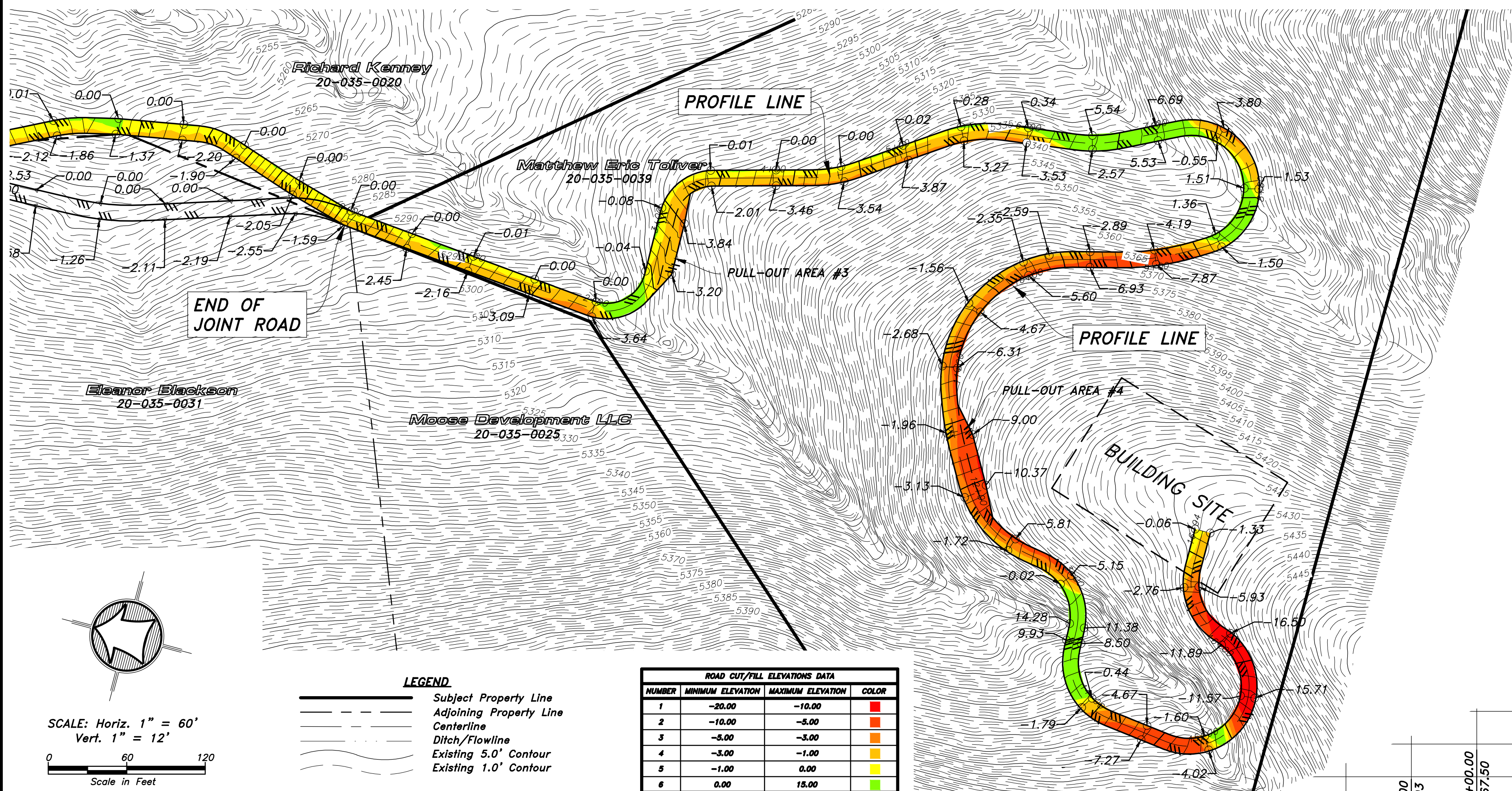

LEGEND

- Subject Property Line
- Adjoining Property Line
- Centerline
- Ditch/Flowline
- Existing 5.0' Contour
- Existing 1.0' Contour

ROAD CUT/FILL ELEVATIONS DATA

NUMBER	MINIMUM ELEVATION	MAXIMUM ELEVATION	COLOR
1	-20.00	-10.00	Red
2	-10.00	-5.00	Orange
3	-5.00	-3.00	Yellow
4	-3.00	-1.00	Light Green
5	-1.00	0.00	Green
6	0.00	15.00	Dark Green

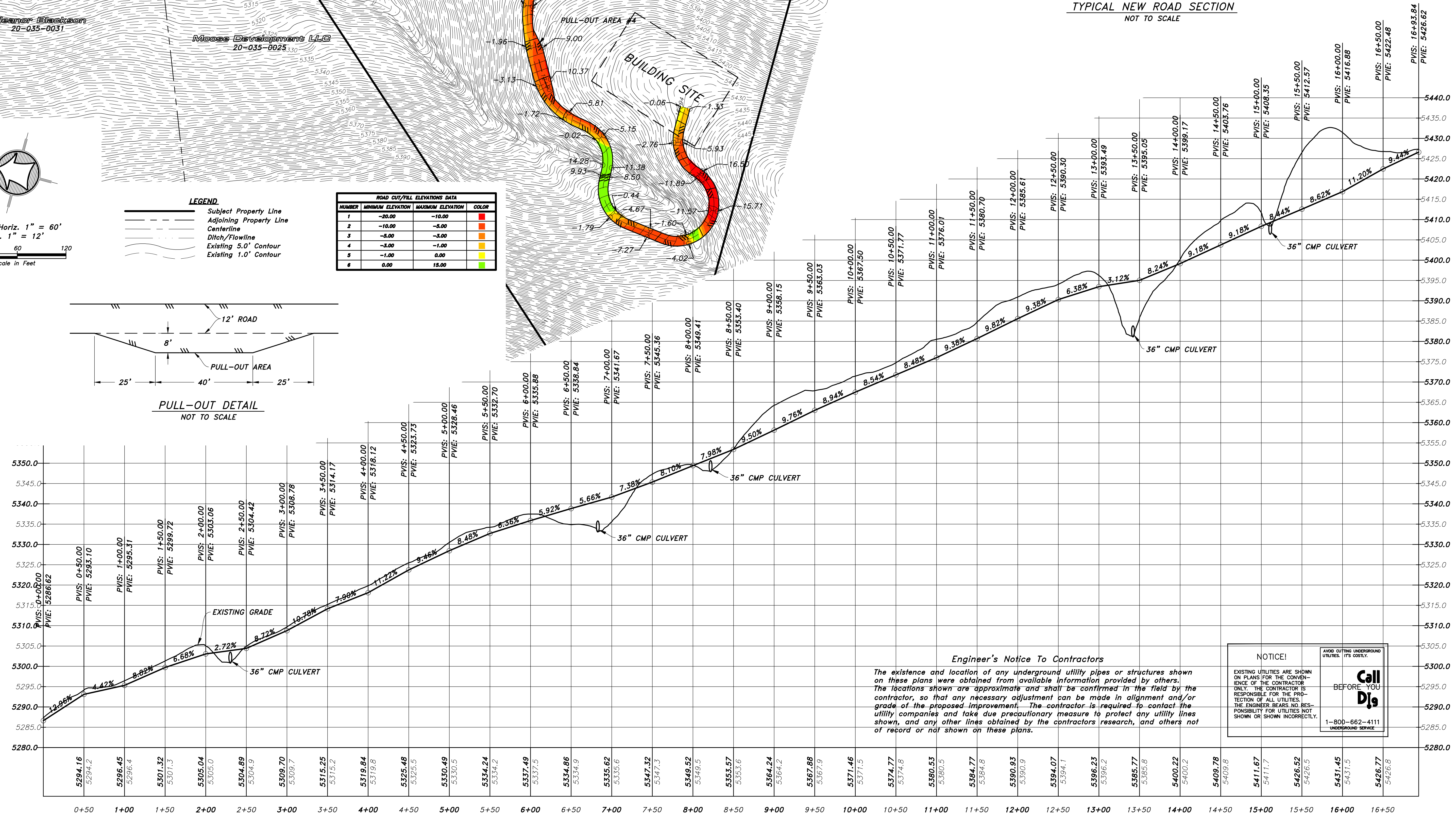
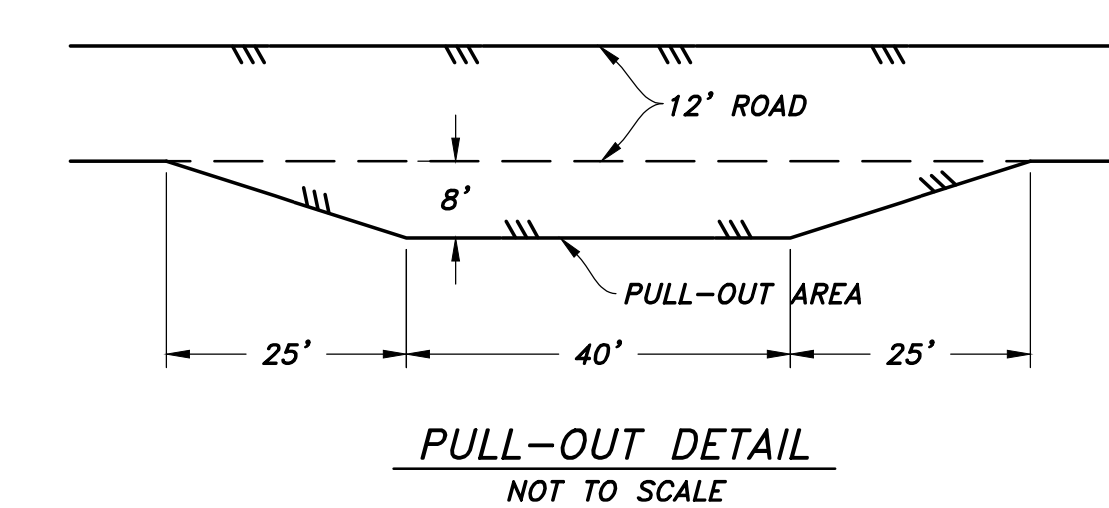

Engineer's Notice To Contractors

The existence and location of any underground utility pipes or structures shown on these plans were obtained from available information provided by others. The locations shown are approximate and shall be confirmed in the field by the contractor, so that any necessary adjustment can be made in alignment and/or grade of the proposed improvement. The contractor is required to contact the utility companies and take due precautionary measure to protect any utility lines shown, and any other lines obtained by the contractors research, and others not of record or not shown on these plans.

NOTICE!

EXISTING UTILITIES ARE SHOWN ON PLANS FOR THE CONVENIENCE OF THE CONTRACTOR ONLY. THE CONTRACTOR IS RESPONSIBLE FOR THE PROTECTION OF ALL UTILITIES. THE ENGINEER BEARS NO RESPONSIBILITY FOR UTILITIES NOT SHOWN OR SHOWN INCORRECTLY.

Call Dig
BEFORE YOU DIG
1-800-662-4111
UNDERGROUND SERVICE

Drawn By: MTH Date: 12/12/16
 Designed By: _____
 Checked By: _____
 Approved By: _____
 Scale: 1" = 60'
 Drawing File: 15-12415pp.DWG
 JOB NUMBER: 15-124

HANSEN & ASSOCIATES, INC.
 Consulting Engineers and Land Surveyors
 538 North Main Street, Brigham, Utah 84302
 Visit us at www.hansen.net
 Brigham City, Utah
 (435) 723-3491 (801) 399-4905 (435) 752-8272

HANSEN & ASSOCIATES, INC.

PLANNED AND PROFILE FOR
MATT TOLIVER
 ADDRESS: HUNTSVILLE DISTRICT
 A Part of the Southeast Quarter of Section 23
 Township 6 North, Range 1 East, S.L.B.&M.

No.	Date	By	Revision

Sheet **2** of **2** Sheets