

PRELIMINARY
MIDDLE FORK RANCHES SECOND AMENDMENT

AMENDING LOT 8
 WEBER COUNTY, UTAH
 A PART OF THE SOUTH HALF OF SECTION 6,
 TOWNSHIP 6 NORTH, RANGE 2 EAST, SALT LAKE BASE & MERIDIAN
 JUNE 2020

SURVEYOR'S CERTIFICATE

I, ROGER C. SLADE, DO HEREBY CERTIFY THAT I AM A REGISTERED PROFESSIONAL LAND SURVEYOR IN THE STATE OF UTAH IN ACCORDANCE WITH TITLE 58, CHAPTER 22, PROFESSIONAL ENGINEERS AND PROFESSIONAL LAND SURVEYORS ACT; AND I HAVE COMPLETED A SURVEY OF THE PROPERTY DESCRIBED ON THIS PLAT IN ACCORDANCE WITH SECTION 17-23-17 AND HAVE VERIFIED ALL MEASUREMENTS, AND HAVE PLACED MONUMENTS AS REPRESENTED ON THIS PLAT, AND HAVE HEREBY AMENDED AND SUBDIVIDED SAID TRACT INTO ONE (1) LOT, KNOWN HEREAFTER AS MIDDLE FORK RANCHES SECOND AMENDMENT, IN WEBER COUNTY, UTAH, AND HAS BEEN CORRECTLY DRAWN TO THE DESIGNATED SCALE AND IS TRUE AND CORRECT REPRESENTATION OF THE HEREIN DESCRIBED LANDS INCLUDED IN SAID SUBDIVISION, BASED UPON DATA COMPILED FROM RECORDS IN THE WEBER COUNTY RECORDER'S OFFICE AND FROM SAID SURVEY MADE BY ME OR UNDER MY SUPERVISION ON THE GROUND, I FURTHER HEREBY CERTIFY THAT THE REQUIREMENTS OF ALL APPLICABLE STATUTES AND ORDINANCES OF WEBER COUNTY CONCERNING ZONING REQUIREMENTS REGARDING LOT MEASUREMENTS HAVE BEEN COMPLIED WITH.

SIGNED THIS _____ DAY OF _____, 2020.

ROGER C. SLADE, P.L.S.
 UTAH LAND SURVEYOR LICENCE NO. 11386802

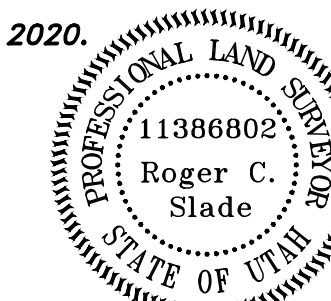

SUBDIVISION BOUNDARY DESCRIPTION

A PART OF THE SOUTH HALF OF SECTION 6, TOWNSHIP 6 NORTH, RANGE 2 EAST, SALT LAKE BASE AND MERIDIAN.

BEGINNING AT THE NORTHEAST CORNER OF LOT 21, MIDDLE FORK RANCHES FIRST AMENDMENT, RECORDED AS ENTRY NO. 2785086 IN THE WEBER COUNTY RECORDER'S OFFICE ALSO BEING THE NORTHWEST CORNER OF LOT 8 MIDDLE FORK RANCHES, RECORDED AS ENTRY NO. 614116 LOCATED 2518.96 FEET NORTH 89°03'22" EAST ALONG THE EAST / WEST CENTER SECTION LINE AND 2.61 FEET SOUTH 00°05'00" WEST TO AN OLD 1/2" REBAR MARKING THE CENTER OF SAID SECTION 6 PER SAID MIDDLE FORK RANCHES AND 81.20 FEET NORTH 89°33'30" EAST FROM THE WEST QUARTER CORNER OF SAID SECTION 6;

RUNNING THENCE NORTH 89°33'30" EAST 281.40 FEET ALONG THE NORTH LINE OF SAID LOT 8 TO THE NORTHEAST CORNER OF TROY AND VICTORIA GREEN PROPERTY, TAX ID NO. 21-005-0036; THENCE ALONG THE BOUNDARY OF SAID GREEN PROPERTY THE FOLLOWING TWO (2) COURSES: (1) SOUTH 01°38'00" WEST 800.00 FEET; AND (2) NORTH 90°00'00" WEST 41.01 FEET TO THE EAST LINE OF SAID LOT 8; THENCE ALONG THE BOUNDARY OF SAID LOT 8 THE FOLLOWING FOUR (4) COURSES (1) SOUTH 00°22'27" WEST 22.69 FEET TO THE NORTH RIGHT-OF-WAY LINE OF 1400 NORTH STREET; (2) NORTH 89°38'00" WEST 177.00 FEET ALONG SAID NORTH RIGHT-OF-WAY LINE; (3) WESTERLY TO THE RIGHT ALONG THE ARC OF A 337.86 FOOT RADIUS CURVE, A DISTANCE OF 134.99 FEET, CHORD BEARS NORTH 78°11'15" WEST 134.09 FEET, HAVING A CENTRAL ANGLE OF 22°53'30" ALONG SAID NORTH RIGHT-OF-WAY LINE TO THE SOUTHEAST CORNER OF SAID LOT 21; AND (4) NORTH 06°32'42" EAST 796.81 FEET ALONG THE EAST LINE OF SAID LOT 21 TO THE POINT OF BEGINNING. CONTAINING 257,630 SQUARE FEET OR 5.914 ACRES.

OWNER'S DEDICATION AND CERTIFICATION

WE THE UNDERSIGNED OWNERS OF THE HEREIN DESCRIBED TRACT OF LAND, DO HEREBY SET APART, AMEND AND SUBDIVIDE THE SAME INTO LOTS AS SHOWN HEREON AND NAME SAID TRACT MIDDLE FORK RANCHES SECOND AMENDMENT, AND DO HEREBY GRANT AND DEDICATE IN PERPETUITY, PURSUANT TO THE PROVISIONS OF 17-27A-607, UTAH CODE, WITHOUT CONDITION, RESTRICTION OR RESERVATION TO WEBER COUNTY, UTAH, ALL THOSE CERTAIN STRIPS OF SAID TRACT OF LAND UPON AND UNDER THE LANDS DESIGNATED HEREOF AS PUBLIC UTILITY EASEMENTS, THE SAME TO BE USED FOR THE INSTALLATION MAINTENANCE AND OPERATION OF PUBLIC UTILITY SERVICE LINES AND DRAINAGE, WITH NO BUILDINGS OR STRUCTURES BEING ERRECTED WITHIN SUCH EASEMENTS. WE HEREBY DECLARE THE PLAT NOTES SHOWN HEREON TO BE EFFECTIVE AND BINDING.

SIGNED THIS _____ DAY OF _____, 2020.

TROY GREEN

VICTORIA GREEN

ACKNOWLEDGMENT

STATE OF UTAH)
)
 COUNTY OF WEBER)

ON THIS _____ DAY OF _____, 2020, TROY GREEN AND VICTORIA GREEN, HUSBAND AND WIFE AS JOINT TENANTS, PERSONALLY APPEARED BEFORE ME, THE UNDERSIGNED NOTARY PUBLIC IN AND FOR SAID COUNTY OF WEBER, IN THE STATE OF UTAH, THE SIGNERS OF THE ATTACHED OWNERS DEDICATION, TWO IN NUMBERS, WHO DULY ACKNOWLEDGED TO ME THEY SIGNED IT FREELY AND VOLUNTARILY AND FOR THE PURPOSE THEREIN MENTIONED.

NOTARY PUBLIC

WEBER COUNTY RECORDER

ENTRY NO. _____ FEE PAID _____

RECORDED _____ FILED FOR RECORD AND

RECORDED _____ IN BOOK _____ OF OFFICIAL

RECORDS, PAGE _____ RECORDED

FOR _____

COUNTY RECORDER

BY: _____ DEPUTY

WEBER COUNTY PLANNING COMMISSION APPROVAL

THIS IS TO CERTIFY THAT THIS SUBDIVISION PLAT WAS DULY APPROVED BY THE WEBER COUNTY PLANNING COMMISSION. SIGNED THIS _____, DAY OF _____, 2020.

CHAIRMAN, WEBER COUNTY PLANNING COMMISSION

WEBER COUNTY ENGINEER

I HEREBY CERTIFY THAT THE REQUIRED PUBLIC IMPROVEMENT STANDARDS AND DRAWINGS FOR THIS SUBDIVISION CONFORM WITH THE COUNTY STANDARDS AND THE AMOUNT OF THE FINANCIAL GUARANTEE IS SUFFICIENT FOR THE INSTALLATION OF THESE IMPROVEMENTS. SIGNED THIS _____, DAY OF _____, 2020.

WEBER COUNTY ENGINEER

WEBER COUNTY ATTORNEY

I HAVE EXAMINED THE FINANCIAL GUARANTEE AND OTHER DOCUMENTS ASSOCIATED WITH THIS SUBDIVISION PLAT, AND IN MY OPINION THEY CONFORM WITH THE COUNTY ORDINANCE APPLICABLE THERETO AND NOW IN FORCE AND AFFECT SIGNED THIS _____, DAY OF _____, 2020.

WEBER COUNTY ATTORNEY

WEBER COUNTY COMMISSION ACCEPTANCE

THIS IS TO CERTIFY THAT THIS SUBDIVISION PLAT, THE DEDICATION OF STREETS AND OTHER PUBLIC WAYS AND FINANCIAL GUARANTEE OF PUBLIC IMPROVEMENTS ASSOCIATED WITH THIS SUBDIVISION, THEREON ARE HEREBY APPROVED AND ACCEPTED BY THE COMMISSIONERS OF WEBER COUNTY UTAH SIGNED THIS _____, DAY OF _____, 2020.

CHAIRMAN, WEBER COUNTY COMMISSION

ATTEST

WEBER COUNTY SURVEYOR

I HEREBY CERTIFY THAT THE WEBER COUNTY SURVEYOR'S OFFICE HAS REVIEWED THIS PLAT AND ALL CONDITIONS FOR APPROVAL BY THIS OFFICE HAVE BEEN SATISFIED. THE APPROVAL OF THIS PLAT BY THE WEBER COUNTY SURVEYOR DOES NOT RELIEVE THE LICENSED LAND SURVEYOR WHO EXECUTED THIS PLAT FROM THE RESPONSIBILITIES AND/OR LIABILITIES ASSOCIATED THERewith. SIGNED THIS _____, DAY OF _____, 2020.

WEBER COUNTY SURVEYOR

NARRATIVE

THE PURPOSE OF THIS SURVEY WAS TO AMEND LOT 8, MIDDLE FORK RANCHES AND PROPERTY TAX ID NO. 21-005-0036 AND TO ESTABLISH AND SET THE PROPERTY CORNERS AS SHOWN AND DESCRIBED HEREON. THIS SURVEY WAS ORDERED BY TROY GREEN. THE CONTROL USED TO ESTABLISH THE PROPERTY CORNERS WAS MIDDLE FORK RANCHES (ENTRY NO. 614116), MIDDLE FORK RANCHES FIRST AMENDMENT (ENTRY NO. 2785086) AND ROS# 4581 ALONG WITH THE EXISTING WEBER COUNTY SURVEYOR MONUMENTATION SURROUNDING SECTION 6, TOWNSHIP 6 NORTH, RANGE 2 EAST, S.L.B.&M.

THE BASIS OF BEARING IS THE EAST / WEST CENTER SECTION LINE OF SAID SECTION WHICH BEARS NORTH 89°07'40" EAST, ROTATED TO MATCH THE BEARINGS SHOWN ON MIDDLE FORK RANCHES.

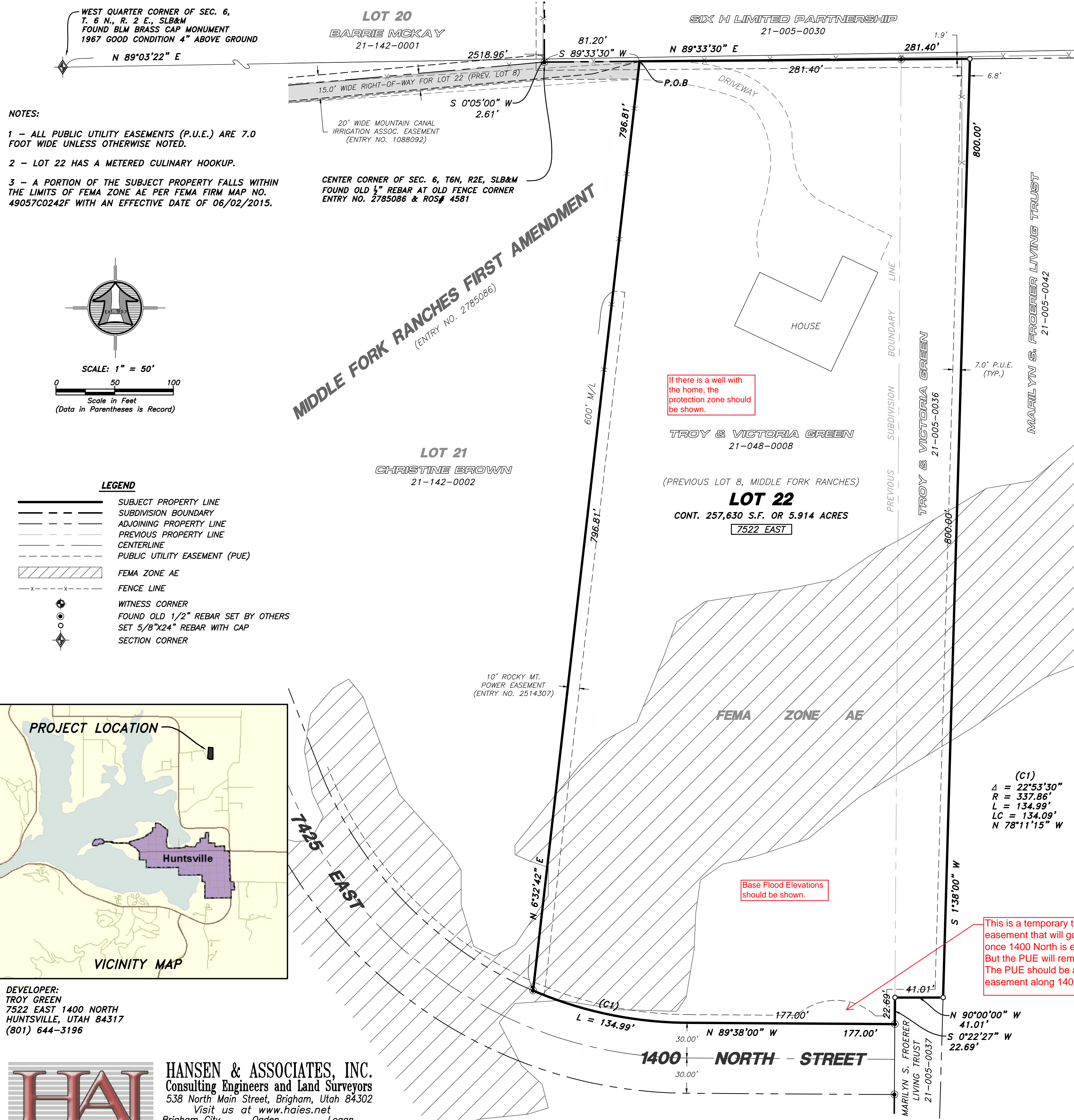

- NOTES:**
- ALL PUBLIC UTILITY EASEMENTS (P.U.E.) ARE 7.0 FOOT WIDE UNLESS OTHERWISE NOTED.
 - LOT 22 HAS A METERED CULINARY HOOKUP.
 - A PORTION OF THE SUBJECT PROPERTY FALLS WITHIN THE LIMITS OF FEMA ZONE AE PER FEMA FIRM MAP NO. 49057C0242F WITH AN EFFECTIVE DATE OF 06/02/2015.

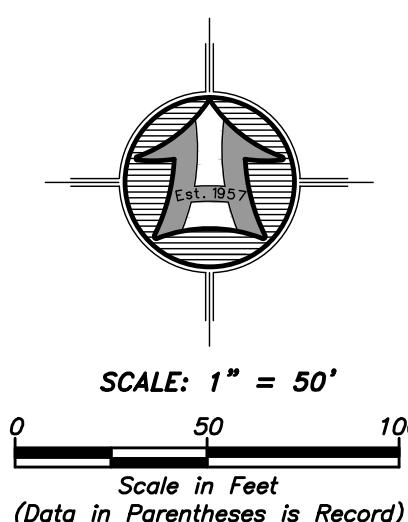

LEGEND

- SUBJECT PROPERTY LINE
- SUBDIVISION BOUNDARY
- ADJOINING PROPERTY LINE
- PREVIOUS PROPERTY LINE
- CENTERLINE
- PUBLIC UTILITY EASEMENT (PUE)
- FEMA ZONE AE
- FENCE LINE
- WITNESS CORNER
- FOUND OLD 1/2" REBAR SET BY OTHERS
- SET 5/8"x24" REBAR WITH CAP
- SECTION CORNER

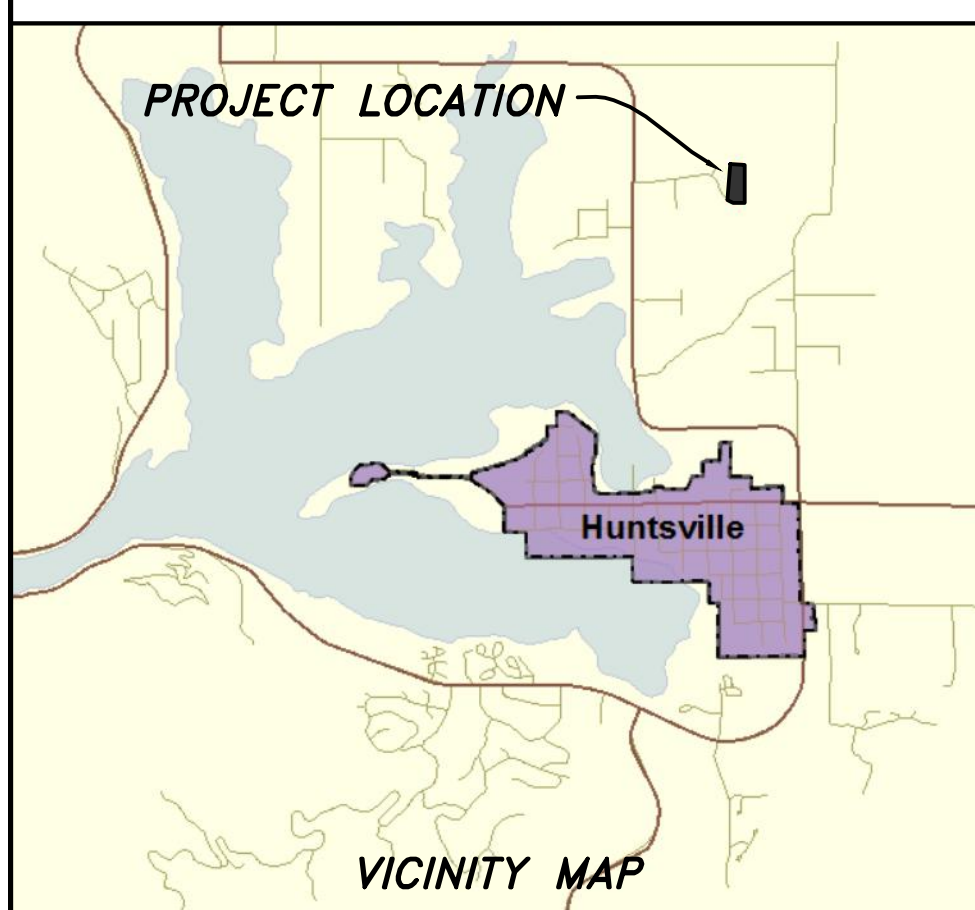

DEVELOPER:
 TROY GREEN
 7522 EAST 1400 NORTH
 HUNTSVILLE, UTAH 84317
 (801) 644-3196

HAI
HANSEN & ASSOCIATES, INC.
 Consulting Engineers and Land Surveyors
 538 North Main Street, Brigham, Utah 84302
 Visit us at www.haies.net
 Brigham City Ogdan Logan
 (435) 723-3491 (801) 399-4905 (435) 752-8272
 Celebrating over 60 Years of Business