

BRICK VENEER **R103.1**
 CORROSION RESISTANT ANCHOR TIES EMBEDDED IN MORTAR OR GROUT AND EXTENDING INTO THE VENEER A MINIMUM OF 1-1/2" INCH, WITH NOT LESS THAN 3/8" MORTAR OR GROUT COVER TO OUTSIDE FACE.
 CORROSION RESISTANT 22 GAGE X 1/8" OR NO. 9 GAGE WIRE SPACED NO MORE THAN 24" O.C. HORIZ. AND VERTICALLY AND SHALL SUPPORT NOT MORE THAN 20 SQUARE FEET OF WALL AREA.
 STEEL ANGLE - MIN. 6"x4"x3/8" WITH THE LONG LEG VERTICAL. COMPLY WITH SECTION R103.1.2.1
 ALL STONE AND MASONRY VENEER SHALL COMPLY WITH SECTION R103.1

ATTIC VENTILATION **R806**
 ATTIC VENTILATION SHALL COMPLY WITH SECTION R806.
 THE NET FREE VENTILATION SHALL NOT BE LESS THAN 1/150th OF THE AREA OF THE SPACE VENTILATED, EXCEPT THAT THE AREA MAY BE 1/300th PROVIDED THAT AT LEAST 50% OF THE REQUIRED VENTILATING AREA IS LOCATED IN THE UPPER SPACE PORTION OF THE SPACE TO BE VENTILATED AND THE REMAINDER IS PROVIDED BY EAVES OR CORNICE VENTS. IRC R806.

EXTERIOR WALL COVERING **R103**
 ALL EXTERIOR COVERINGS SHALL COMPLY WITH SECTION R103
 STUCCO (EIFS) - INSTALLATION SHALL COMPLY WITH ASTM E 2568
 FIBER CEMENT SIDING - PANEL AND LAP SIDING INSTALLATION SHALL COMPLY WITH ASTM C1186.
 VINYL SIDING - INSTALLATION SHALL COMPLY PER ASTM D 3679
 ASPHALT SHINGLES - INSTALLATION SHALL COMPLY WITH ASTM D 225 OR D 3462, CLASS "A"

BUILDING ADDRESS **IRC R319.1**
 BUILDING NUMBERS SHALL BE A MIN. 4" HIGH WITH A MINIMUM STROKE WITH OF 1/8" INCH.

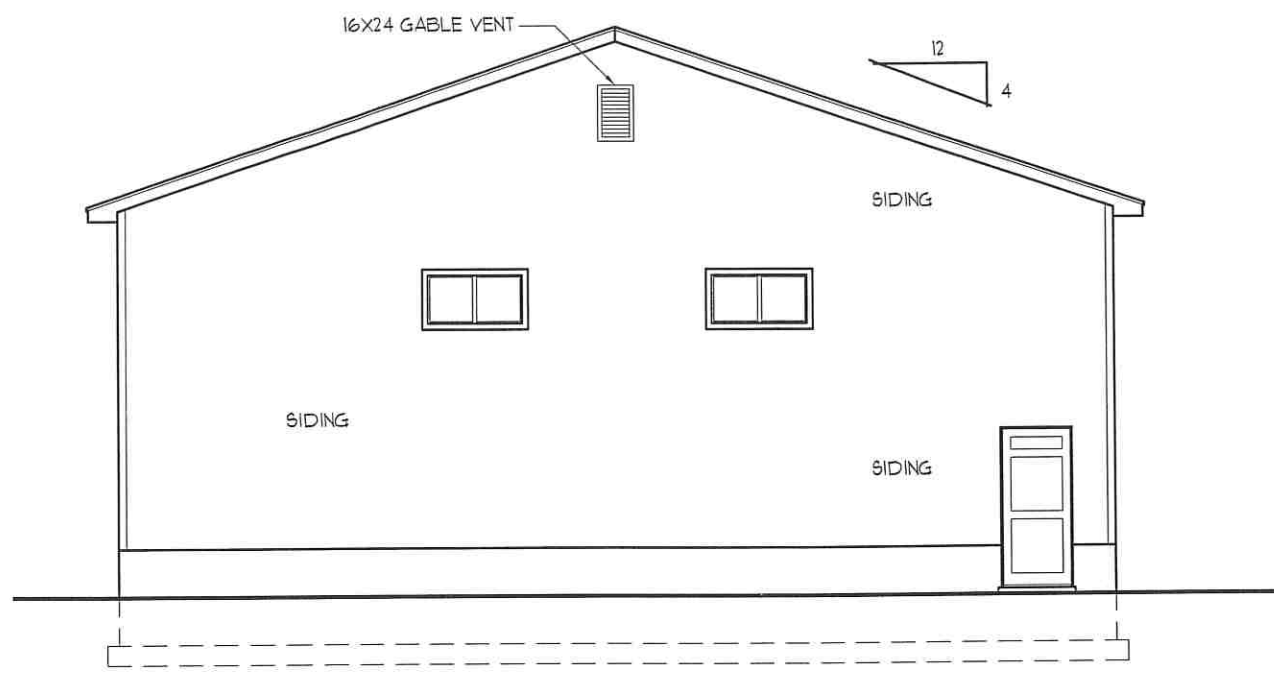

LEFT SIDE VIEW
 SCALE 1/8" = 1'-0"

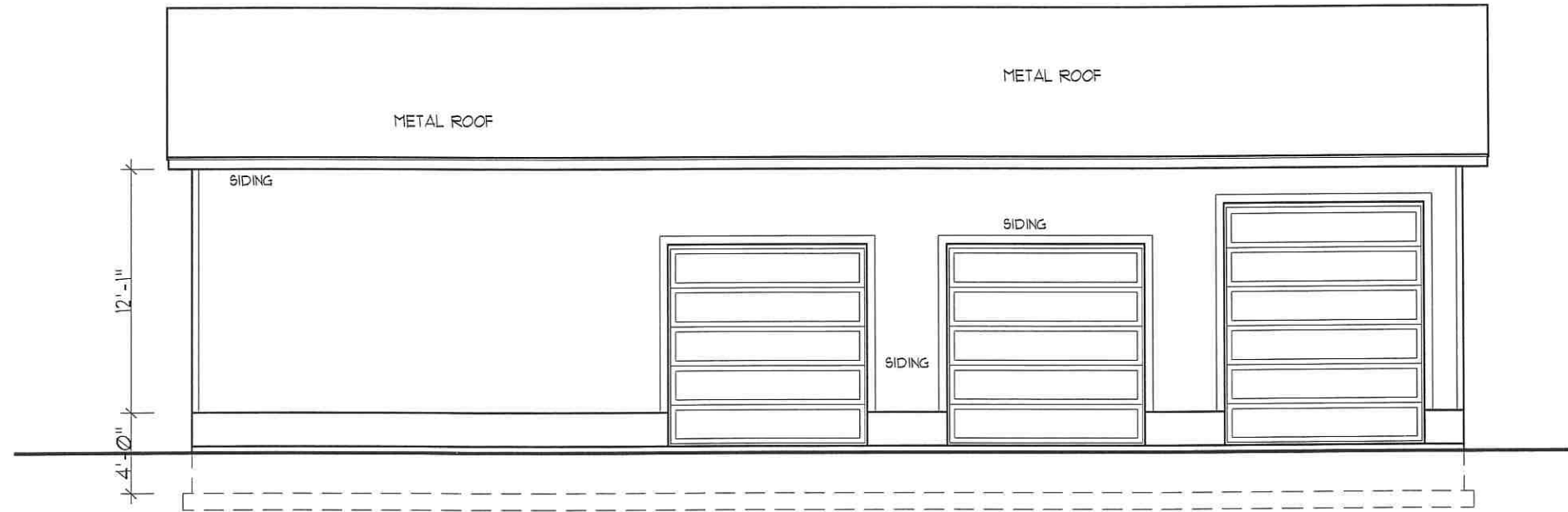

FRONT ELEV. VIEW
 SCALE 1/8" = 1'-0"



4157 W. 2200 S. Taylor, Utah
McGINNIS RESIDENCE

Kustom House Plans
 RESIDENTIAL / COMMERCIAL DESIGN & ENGINEERING
 NATE KARRAS P.E. (801) 786-0849 email: KustomNK@gmail.com

SCALE	11x17
1/8" = 1'-0"	11x17
1/4" = 1'-0"	24x36
PLAN NUMBER	
McGinnis	A1

NOTE THIS PLAN IS THE PROPERTY OF KUSTOM HOUSE PLANS
 DO NOT COPY WITHOUT WRITTEN PERMISSION

BRICK VENEER **R103.1**
 CORROSION RESISTANT ANCHOR TIES EMBEDDED IN MORTAR OR GROUT AND EXTENDING INTO THE VENEER A MINIMUM OF 1-1/2" INCH, WITH NOT LESS THAN 3/8" MORTAR OR GROUT COVER TO OUTSIDE FACE.
 CORROSION RESISTANT 22 GAGE X 7/8" OR NO. 9 GAGE WIRE SPACED NO MORE THAN 24" O.C. HORIZ. AND VERTICALLY, AND SHALL SUPPORT NOT MORE THAN 7.0 SQUARE FEET OF WALL AREA.
 STEEL ANGLE - MIN. 6"x4"x3/8" WITH THE LONG LEG VERTICAL. COMPLY WITH SECTION R103.1.2.1
 ALL STONE AND MASONRY VENEER SHALL COMPLY WITH SECTION R103.1

ATTIC VENTILATION **R306**
 ATTIC VENTILATION SHALL COMPLY WITH SECTION R306.
 THE NET FREE VENTILATION SHALL NOT BE LESS THAN 1/50th OF THE AREA OF THE SPACE VENTILATED, EXCEPT THAT THE AREA MAY BE 1/30th PROVIDED THAT AT LEAST 50% OF THE REQUIRED VENTILATING AREA IS LOCATED IN THE UPPER SPACE PORTION OF THE SPACE TO BE VENTILATED AND THE REMAINDER IS PROVIDED BY EAVES OR CORNICE VENTS. IRC R306.

EXTERIOR WALL COVERING **R103**
 ALL EXTERIOR COVERINGS SHALL COMPLY WITH SECTION R103
 STUCCO(EIPS) - INSTALLATION SHALL COMPLY WITH ASTM E 2568
 FIBER CEMENT SIDING - PANEL AND LAP SIDING INSTALLATION SHALL COMPLY WITH ASTM C1186.
 VINYL SIDING - INSTALLATION SHALL COMPLY PER ASTM D 3619
 ASPHALT SHINGLES - INSTALLATION SHALL COMPLY WITH ASTM D 225 OR D 3462, CLASS "A"

BUILDING ADDRESS **IRC R319.1**
 BUILDING NUMBERS SHALL BE A MIN. 4" HIGH WITH A MINIMUM STROKE WIDTH OF 1/8" INCH.

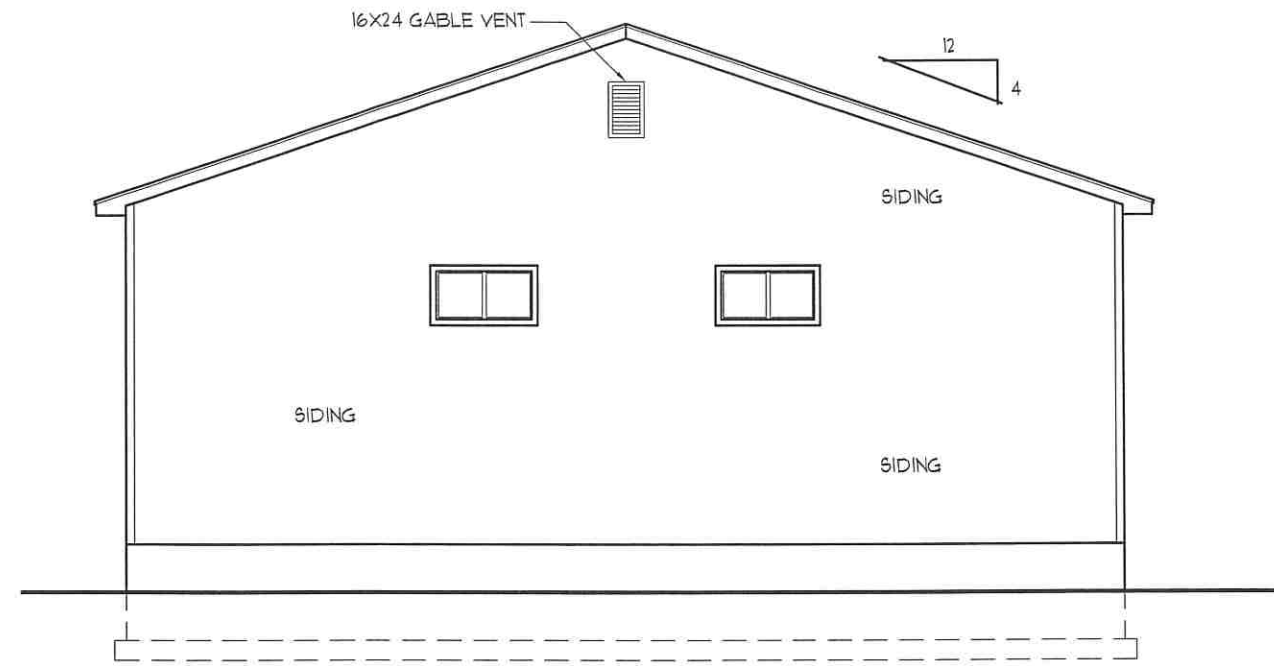

RIGHT SIDE VIEW
 SCALE 1/8" = 1'-0"

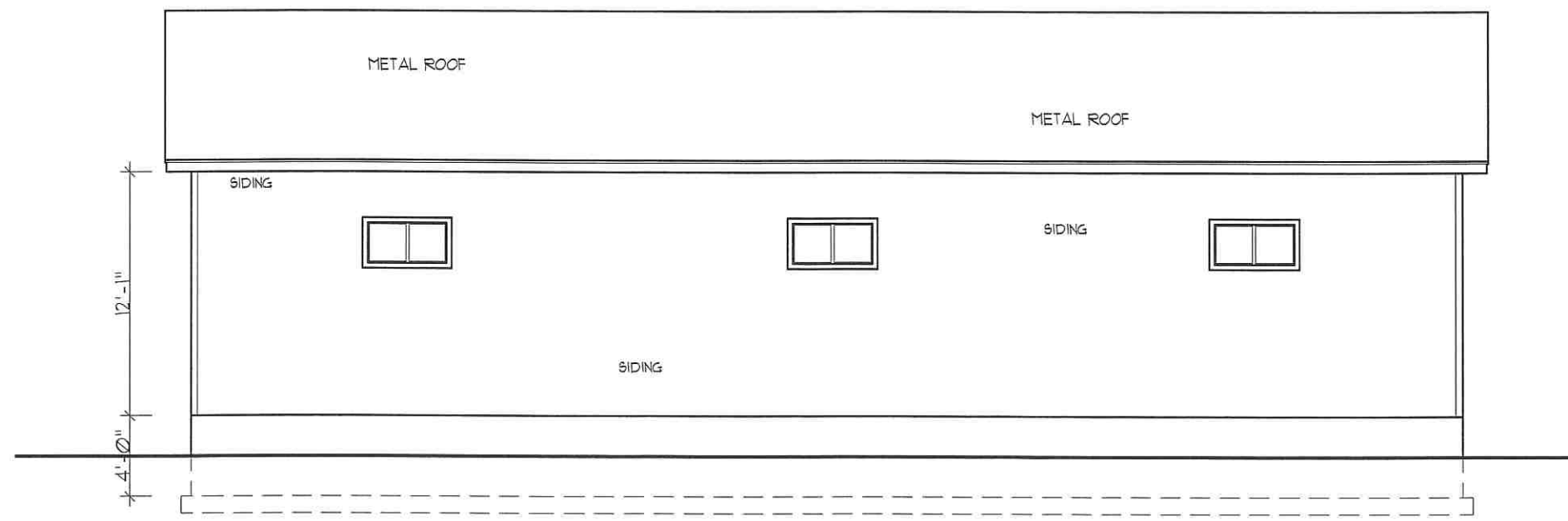

REAR ELEV. VIEW
 SCALE 1/8" = 1'-0"



4157 W. 2200 S. Taylor, Utah
 MCGINNIS RESIDENCE

Kustom House Plans
 RESIDENTIAL / COMMERCIAL DESIGN & ENGINEERING
 NATE KARRAS P.E. (801) 786-0849 email: KustomNK@gmail.com
 NOTE THIS PLAN IS THE PROPERTY OF KUSTOM HOUSE PLANS
 DO NOT COPY WITHOUT WRITTEN PERMISSION

SCALE		
1/8" = 1'-0"	11x17	
1/4" = 1'-0"	24x36	
PLAN NUMBER	A2	
McGinnis		

NOTES: GENERAL

1. CONTRACTOR IS TO VERIFY DESIGN, DIMENSIONS AND NOTES PRIOR TO BEGINNING OF CONSTRUCTION.
2. ALL WORK IS TO BE DONE UNDER THE SUPERVISION OF A LICENSED CONTRACTOR.
3. ALL WORK IS TO BE DONE UNDER LOCAL AND STATE BUILDING CODES.
4. ELECTRICAL SHALL BE PER NATIONAL ELECTRIC CODE, LATEST EDITIONS.
5. HEATING/MECHANICAL WORK SHALL BE PER APPLICABLE CODES, LATEST EDITIONS.

NOTES: STRUCTURAL

SEE STRUCTURAL DETAILS - SHEET S-1, S-2, AND S-3

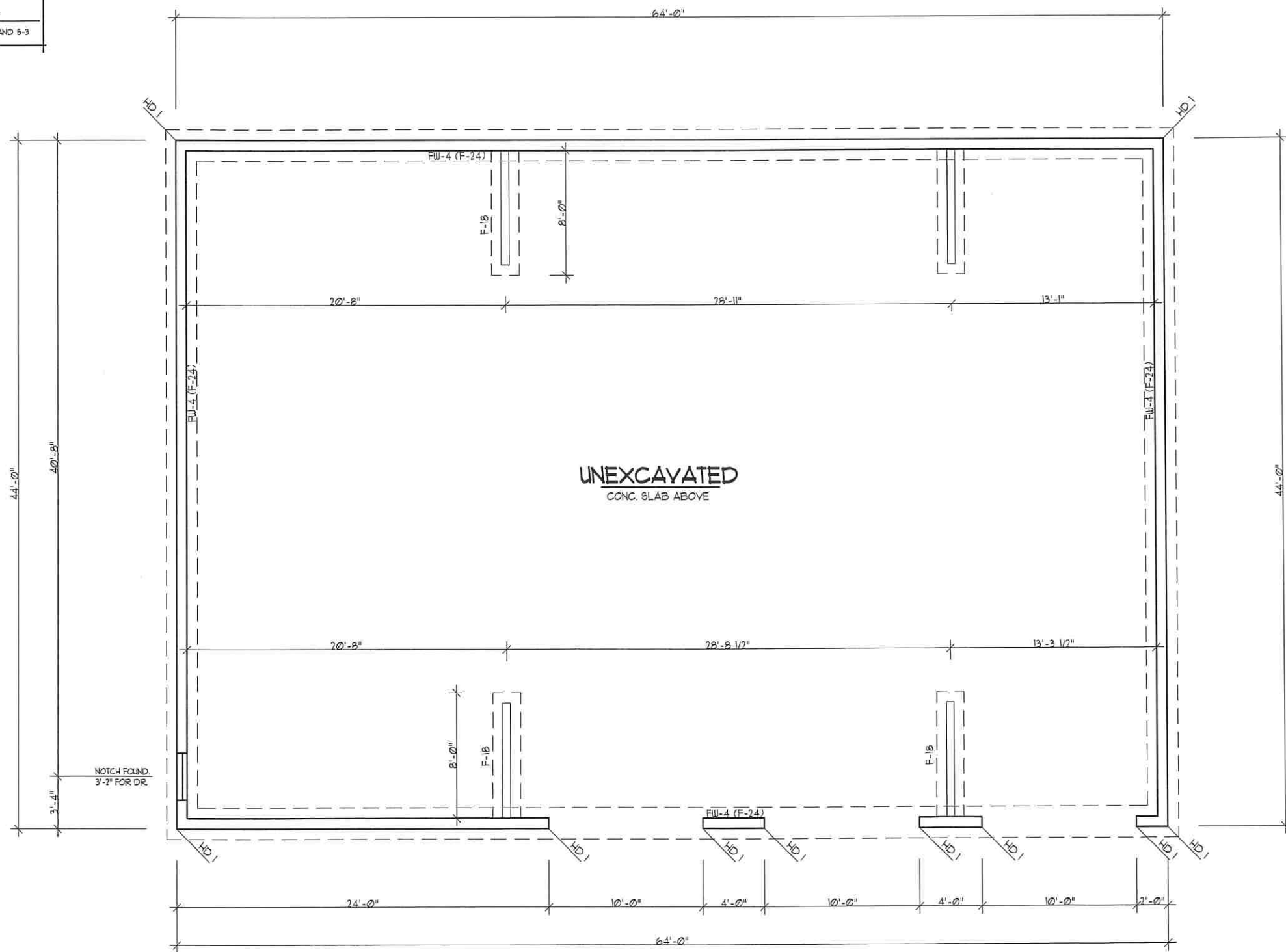

FOUNDATION PLAN
SCALE 1/8" = 1'-0"



Kustom House Plans
4157 W. 2200 S. Taylor, Utah
McGINNIS RESIDENCE

RESIDENTIAL / COMMERCIAL DESIGN & ENGINEERING
NATE KARRAS P.E. (801) 786-0849 email: KustomNK@gmail.com
NOTE THIS PLAN IS THE PROPERTY OF KUSTOM HOUSE PLANS
DO NOT COPY WITHOUT WRITTEN PERMISSION

SCALE	1/8" = 1'-0"	11x17
	1/4" = 1'-0"	24x36
PLAN NUMBER	McGinnis A3	

NOTES: GENERAL

1. CONTRACTOR IS TO VERIFY DESIGN, DIMENSIONS AND NOTES PRIOR TO BEGINNING OF CONSTRUCTION.
2. ALL WORK IS TO BE DONE UNDER THE SUPERVISION OF A LICENSED CONTRACTOR.
3. ALL WORK IS TO BE DONE UNDER LOCAL AND STATE BUILDING CODES.
4. ELECTRICAL SHALL BE PER NATIONAL ELECTRIC CODE, LATEST EDITIONS.
5. HEATING/MECHANICAL WORK SHALL BE PER APPLICABLE CODES, LATEST EDITIONS.

NOTES: STRUCTURAL

SEE STRUCTURAL DETAILS - SHEET S-1, S-2, AND S-3

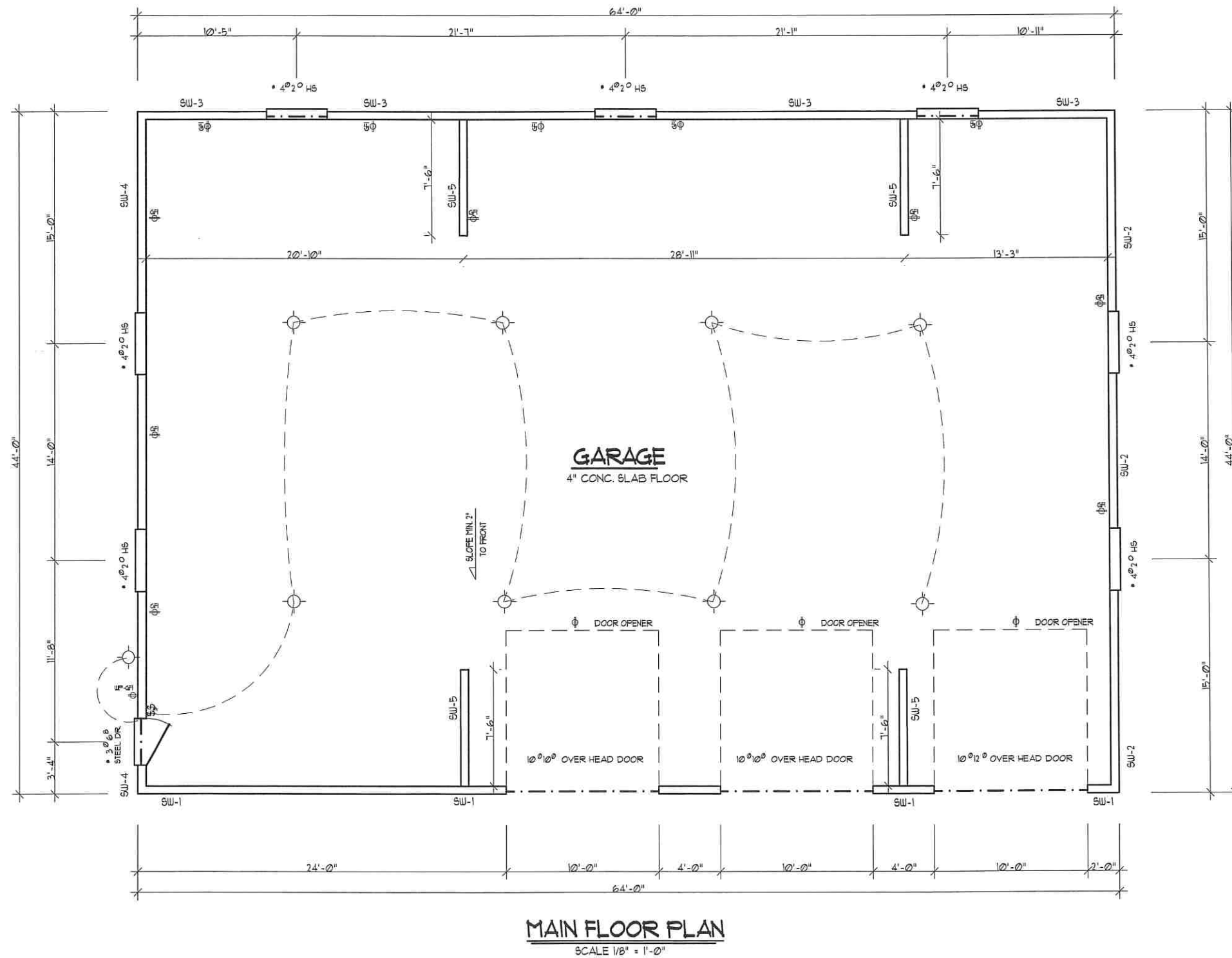

Kustom House Plans
 4157 W. 2200 S. Taylor, Utah
McGINNIS RESIDENCE

Kustom House Plans
 RESIDENTIAL / COMMERCIAL DESIGN & ENGINEERING
 NATE KARRAS P.E. (801) 786-0849 email: KustomNK@gmail.com
 NOTE THIS PLAN IS THE PROPERTY OF KUSTOM HOUSE PLANS
 DO NOT COPY WITHOUT WRITTEN PERMISSION

SCALE	1/8" = 1'-0"	11x17
	1/4" = 1'-0"	24x36
PLAN NUMBER	McGinnis A4	

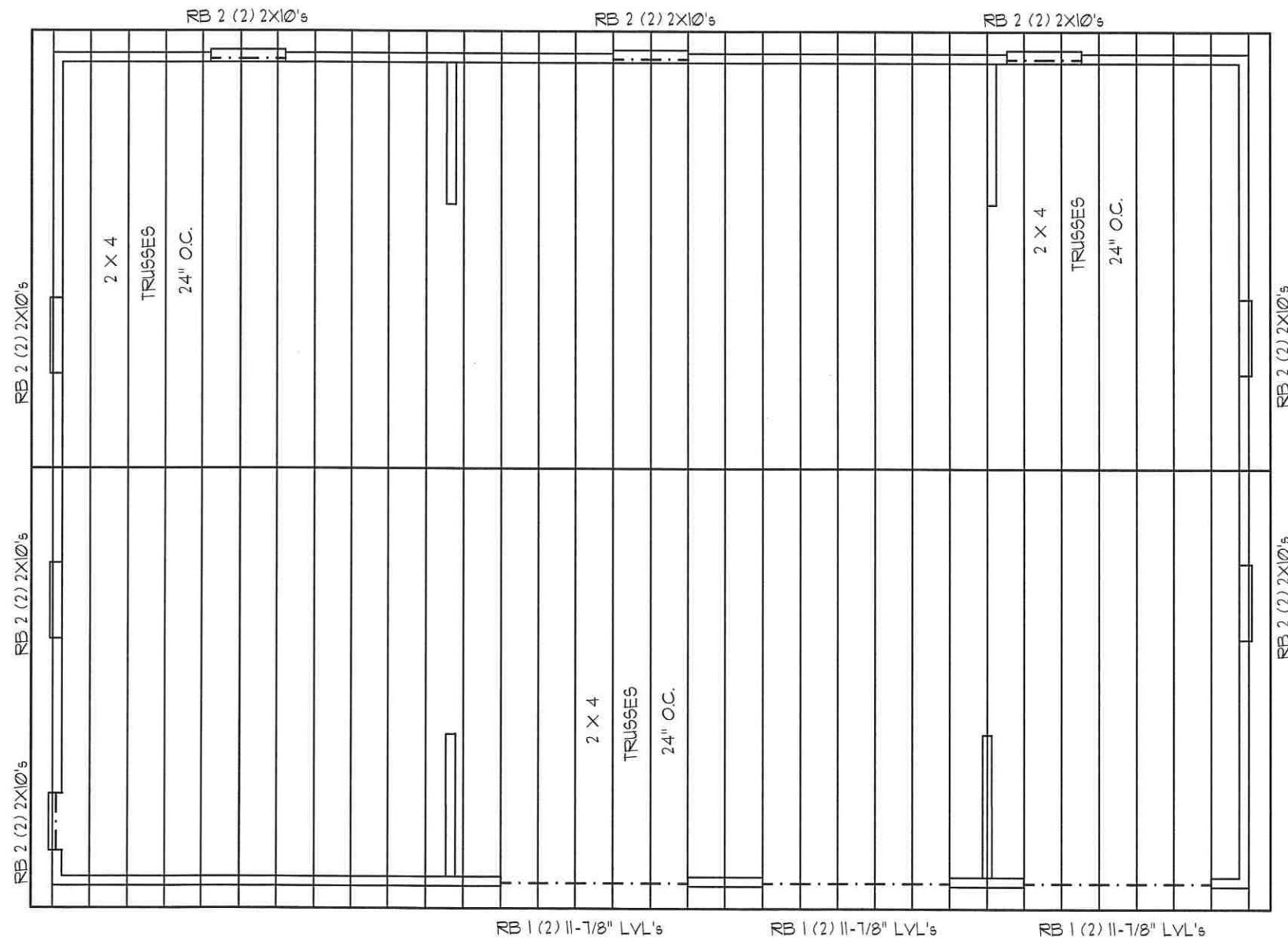

ROOF FRAMING PLAN
SCALE 1/8" = 1'-0"

NOTES: PRE-MANUFACTUR TRUSSES

PRE-MANUFACTURED TRUSSES SHALL CONFORM WITH SECTION R202.10 AND R502.11.

TRUSS MANUFACTURE SHALL PROVIDE DETAILS AND INSTRUCTION FOR HANDLING, INSTALLING, RESTRAINING, AND BRACING OF TRUSSES BEFORE AND AFTER CONSTRUCTION.

TRUSS DESIGN DRAWINGS SHALL BE PREPARED BY A REGISTERED PROFESSIONAL WHERE REQUIRED BY THE STATUES OF THE JURISDICTION IN WHICH THE PROJECT IS TO BE CONSTRUCTED IN ACCORDANCE WITH SECTION R106.1.

NO ALTERATIONS SHALL BE MADE TO THE TRUSSES OR THE TRUSS LAYOUT.

ANY CHANGES TO THE ROOF FRAMING PLAN SHALL BE BROUGHT TO THE ATTENTION OF THE DESIGN ENGINEER PRIOR TO MANUFACTURING AND OR CONSTRUCTION OF SAID TRUSSES.

TRUSS DESIGN DRAWINGS SHALL COMPLY WITH SECTION R502.11.4 + R202.10.1.

NOTES: GENERAL

1. CONTRACTOR IS TO VERIFY DESIGN DIMENSIONS AND NOTES PRIOR TO BEGINNING OF CONSTRUCTION.
2. ALL WORK IS TO BE DONE UNDER THE SUPERVISION OF A LICENSED CONTRACTOR.
3. ALL WORK IS TO BE DONE UNDER LOCAL AND STATE BUILDING CODES.
4. ELECTRICAL SHALL BE PER NATIONAL ELECTRIC CODE, LATEST EDITIONS.
5. HEATING/MECHANICAL WORK SHALL BE PER APPLICABLE CODES, LATEST EDITIONS.

NOTES: STRUCTURAL

SEE STRUCTURAL DETAILS - SHEET S-1, S-2, AND S-3



Kustom House Plans
RESIDENTIAL / COMMERCIAL DESIGN & ENGINEERING
NATE KARKAS P.E. (801) 786-0849 email: kustomhkp@gmail.com

4157 W. 2200 S. Taylor, Utah
McGINNIS RESIDENCE

NOTE THIS PLAN IS THE PROPERTY OF KUSTOM HOUSE PLANS
DO NOT COPY WITHOUT WRITTEN PERMISSION

SCALE	11x17
1/8" = 1'-0"	11x17
1/4" = 1'-0"	24x36
PLAN NUMBER	A5
McGinnis	

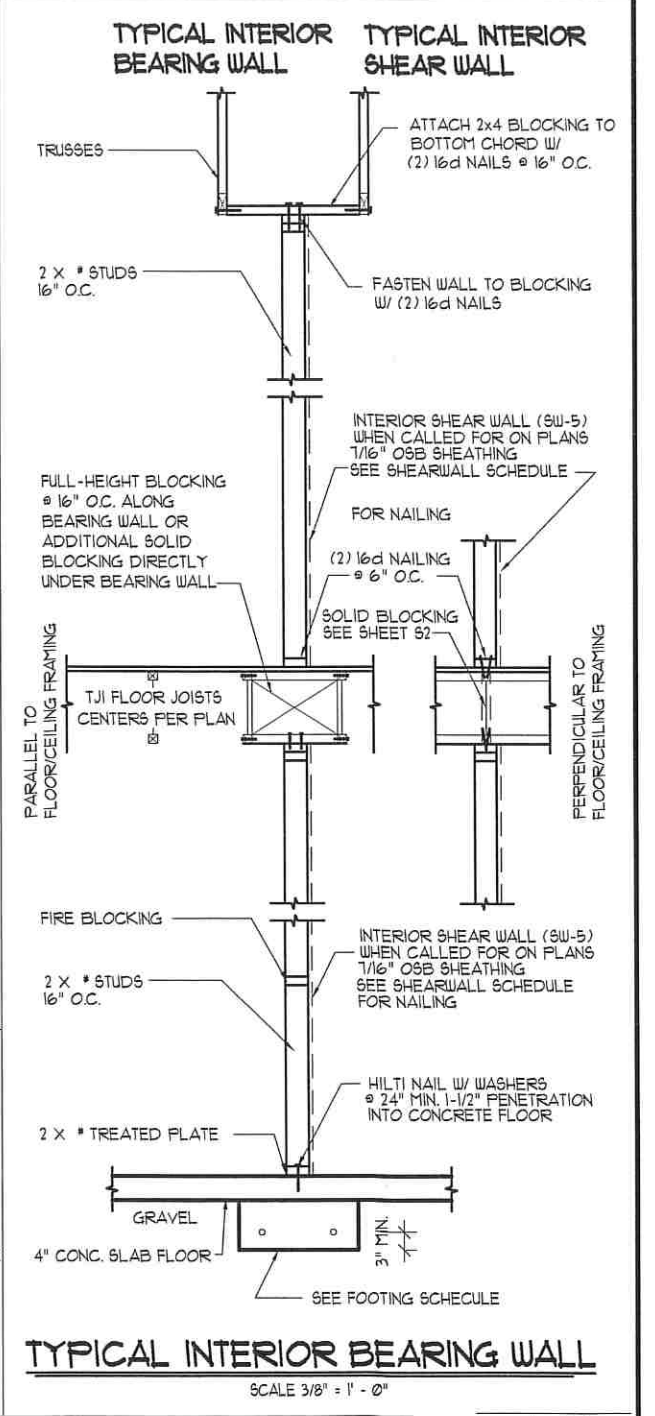
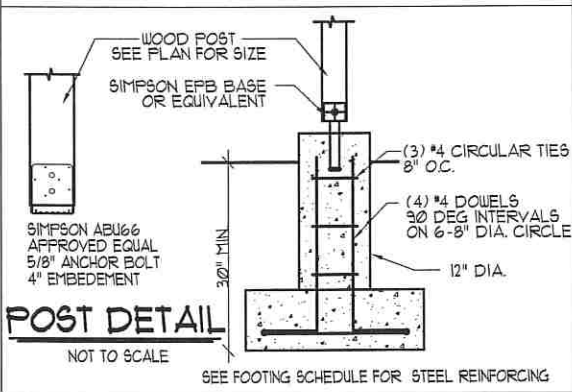
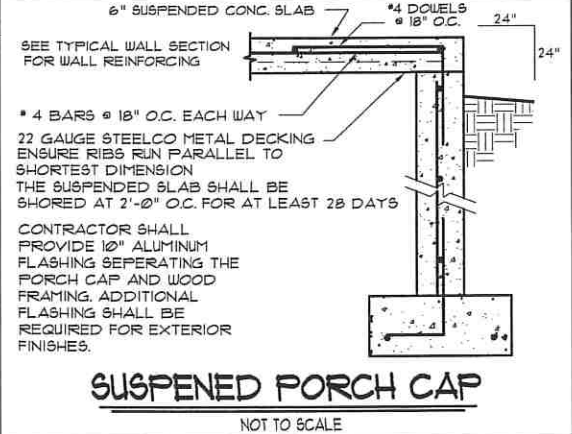
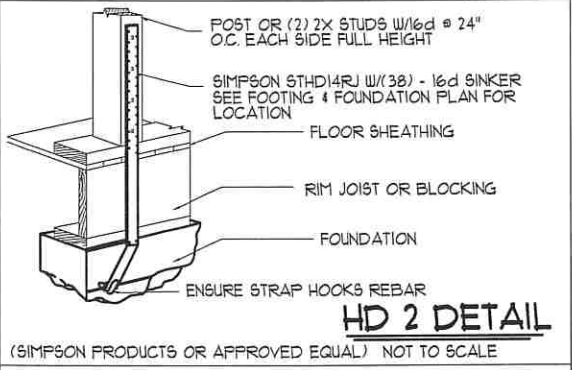
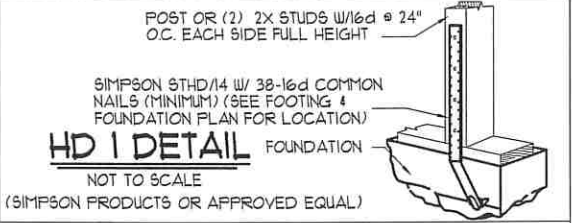
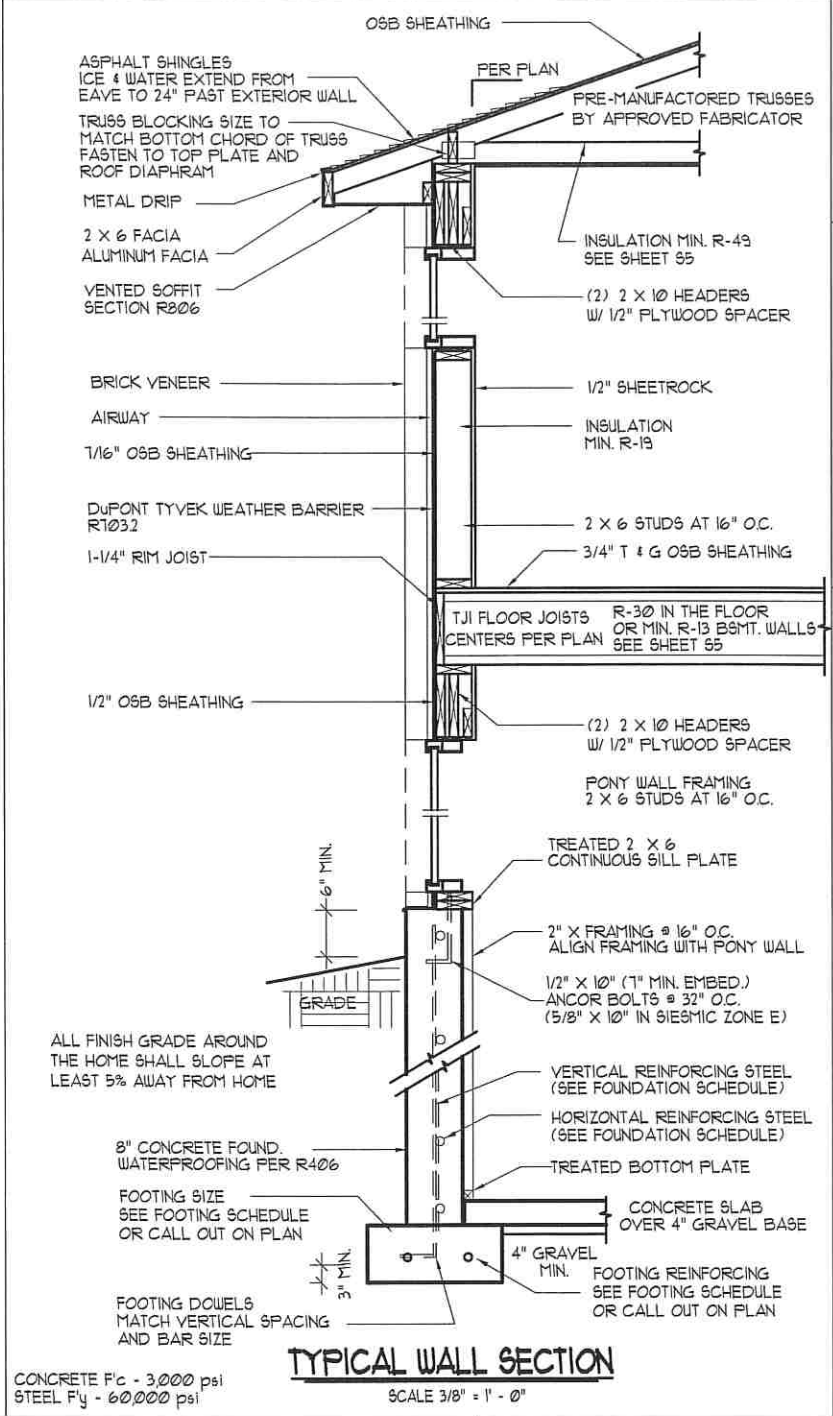
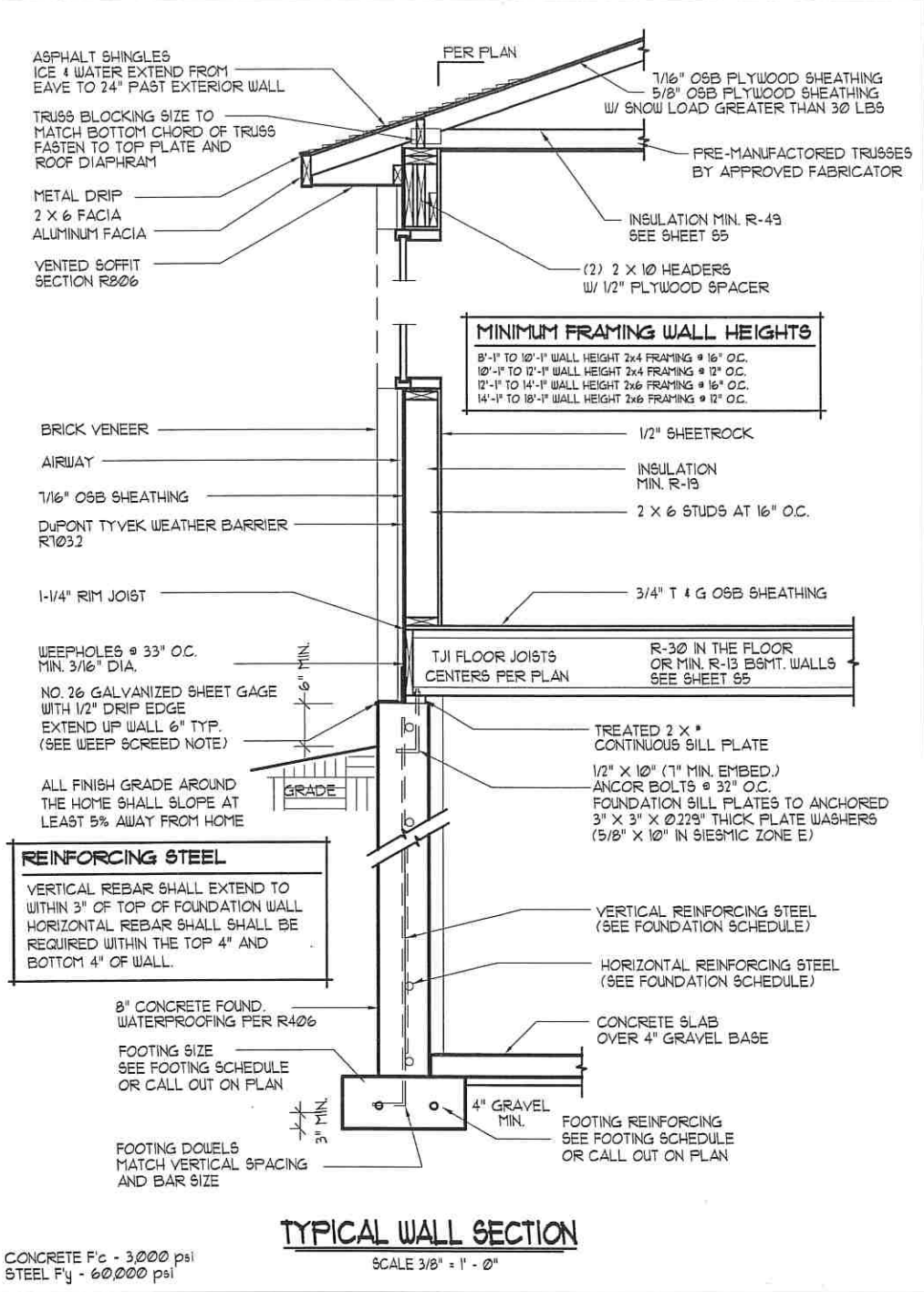

FOUNDATION WALL SCHEDULE
CONCRETE F'c - 3,000 psi
STEEL F'y - 60,000 psi

MARK	WALL HEIGHT	WIDTH	REINFORCING STEEL SPACING		NOTES	
			HORIZONTAL BAR	VERTICAL BAR		
FW-3	3'-0"	8"	* 4 BARS @ 9" O.C.	3	* 4 BARS @ 32" O.C.	PER STATE AMENDMENT (SEE WALL SECTION)
FW-4	3'-6"	8"	* 4 BARS @ 13" O.C.	4	* 4 BARS @ 24" O.C.	PER STATE AMENDMENT (SEE WALL SECTION)
FW-6	6'-0"	8"	* 4 BARS @ 18" O.C.	5	* 4 BARS @ 24" O.C.	(SEE WALL SECTION)
FW-8	8'-0"	8"	* 4 BARS @ 18" O.C.	6	* 4 BARS @ 24" O.C.	(SEE WALL SECTION)
FW-9	9'-0"	8"	* 4 BARS @ 18" O.C.	7	* 4 BARS @ 16" O.C.	(SEE WALL SECTION)

FOOTING SCHEDULE
CONCRETE F'c - 3,000 psi
STEEL F'y - 60,000 psi

MARK	NOMINAL SIZES		LENGTH	REINFORCING STEEL			NOTES
	WIDTH	THICKNESS		LENGTHWISE	# OF BARS	CROSSWISE	
F-18	18"	9"	CONT.	* 4 BARS	2	* 2F BARS	(SEE WALL TYPICAL WALL SECTION)
F-20	20"	10"	CONT.	* 4 BARS	2		(SEE WALL TYPICAL WALL SECTION)
F-24	24"	10"	CONT.	* 4 BARS	3		(SEE WALL TYPICAL WALL SECTION)
F-30	30"	10"	CONT.	* 4 BARS	3		(SEE WALL TYPICAL WALL SECTION)
F-36	36"	12"	CONT.	* 4 BARS	4		(SEE WALL TYPICAL WALL SECTION)
P-24	24"	10"	24"	* 4 BARS	3	* 4 BARS	3 (SEE POST DETAIL)
P-30	30"	10"	30"	* 4 BARS	3	* 4 BARS	3 (SEE POST DETAIL)
P-36	36"	12"	36"	* 4 BARS	4	* 4 BARS	4 (SEE POST DETAIL)
P-48	48"	12"	48"	* 4 BARS	5	* 4 BARS	5 (SEE POST DETAIL)

GENERAL NOTES

- CONTRACTOR IS TO VERIFY DESIGN, DIMENSIONS AND NOTES PRIOR TO BEGINNING OF CONSTRUCTION.
- ALL WORK IS TO BE DONE UNDER THE SUPERVISION OF A LICENSED CONTRACTOR.
- ALL WORK IS TO BE DONE UNDER LOCAL AND STATE BUILDING CODES.
- ELECTRICAL SHALL BE PER NATIONAL ELECTRIC CODE, LATEST EDITIONS.
- HEATING/MECHANICAL WORK SHALL BE PER APPLICABLE CODES, LATEST EDITIONS.

FOUNDATION WALL NOTES

- WALLS GREATER THAN 10'-0" SEE ENGINEERING
- REINFORCING STEEL SHALL BE PLACED IN CENTER OF WALL
- FOOTING DOUELS SHALL MATCH VERTICAL STEEL AND EXTEND A MIN. OF 24" INTO FOUNDATION WALL.
- MIN. SPLICE LENGTH
* 4 BAR 24" INCHES - * 5 BAR 30" INCHES
- CORNER REINFORCING - LAP 24" INCHES
- OPENINGS - BARS SHALL BE PLACED WITHIN TWO INCHES OF OPENINGS AND EXTEND 24" BEYOND THE EDGE OPENING.

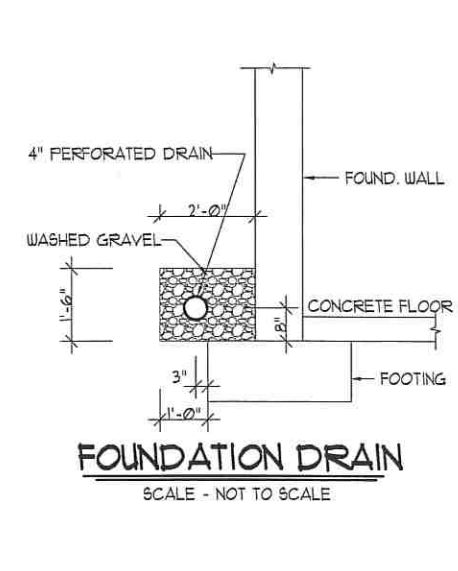

NOTES: FOUNDATION DRAINAGE - R405

LAND DRAIN - IF A LAND DRAIN IS AVAILABLE THE FOUNDATION DRAIN SYSTEM SHALL BE EXTENDED AND CONNECTED TO THE LAND DRAIN.

A SUMP SHALL BE PROVIDED TO DRAIN THE POROUS LAYER AND FOOTINGS. THE SUMP SHALL BE AT LEAST 24 INCHES IN DIAMETER OR 20 INCHES SQUARE, SHALL EXTEND AT LEAST 24 INCHES BELOW THE BOTTOM OF THE BASEMENT FLOOR AND SHALL BE CAPABLE OF POSITIVE GRAVITY OR MECHANICAL DRAINAGE TO REMOVE ANY ACCUMULATED WATER. THE DRAINAGE SYSTEM SHALL DISCHARGE INTO AN APPROVED SEWER SYSTEM OR TO DAYLIGHT.

EXCEPTION - A DRAINAGE SYSTEM IS NOT REQUIRED WHEN THE FOUNDATION IS INSTALLED ON WELL-DRAINED GROUND OR SAND GRAVEL MIXTURE SOILS ACCORDING TO THE UNITED SOIL CLASSIFICATION SYSTEM, GROUP I SOILS, AS DETAILED IN TABLE R405.1.

PORTIONS OF THE DWELLING THAT ARE BELOW GRADE SHALL BE AT A DEPTH SIMILAR TO THE SURROUNDING DWELLINGS. IF GROUND WATER IS OBSERVED AT TIME OF EXCAVATION, A GEOTECHNICAL ENGINEER SHALL EVALUATE THE SITE AND PROVIDE RECOMMENDATIONS. ALL RECOMMENDATIONS THAT ARE PROVIDED SHALL BE FOLLOWED.

GRAVEL OR CRUSHED STONE DRAINS SHALL EXTEND AT LEAST 1 FT BEYOND THE OUTSIDE EDGE OF THE FOOTING AND 6 INCHES ABOVE THE TOP OF THE FOOTING AND BE COVERED WITH AN APPROVED FILTER MEMBRANE MATERIAL. THE TOP OF OPEN JOINTS OF DRAIN TILES SHALL BE PROTECTED WITH STRIPS OF BUILDING PAPER. COVER THE WASHED GRAVEL OR CRUSHED ROCK COVERING THE DRAIN. DRAINAGE TILES OR PERFORATED PIPE SHALL BE PLACED ON A MINIMUM OF 2 IN. OF WASHED GRAVEL OR CRUSHED ROCK AT LEAST ONE SIEVE SIZE LARGER THAN THE TILE JOINT OPENING OR PERFORATION AND COVERED WITH NOT LESS THAN 6 INCHES OF THE SAME MATERIAL.

PROFESSIONAL STRUCTURAL ENGINEER
No. 353825
NATHAN JOHN KARRAS
3/24/2019
STATE OF UTAH

Karras Engineering
RESIDENTIAL / COMMERCIAL DESIGN & ENGINEERING
NATE KARRAS P.E. (801) 766-0849 email: kustomnk@gmail.com

NOTE THIS PLAN IS THE PROPERTY OF KUSTOM HOUSE PLANS
DO NOT COPY WITHOUT WRITTEN PERMISSION

SCALE
1/8" = 1'-0" 11x17
1/4" = 1'-0" 24x36
PLAN NUMBER
JAN 2019 **S1**

HD 3 DETAIL

NOT TO SCALE

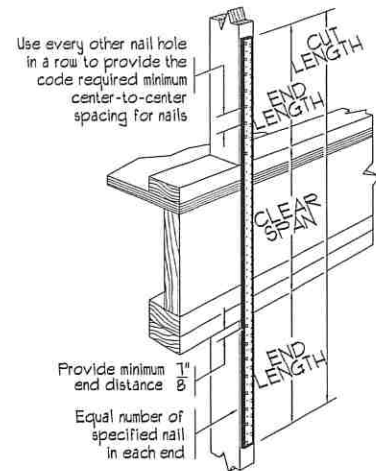

(SIMPSON PRODUCTS OR APPROVED EQUAL) SIMPSON MST48 STRAP TIE
COLUMN LOADS CANNOT BE SUPPORTED BY WOOD JOISTS

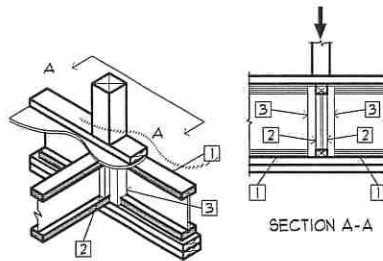

- 1] BLOCKING PANEL BY JOIST MANUFACTURER
- 2] WEB STIFFENER BY JOIST MANUFACTURER EACH SIDE OF JOIST
- 3] 2 x 4 MIN BLOCKS BY CONTR EA. SIDE OF JOIST TO SUPPORT COLUMN LOAD (LENGTH = JOIST DEPTH + 1)

SOLID BLOCKING

NOT TO SCALE

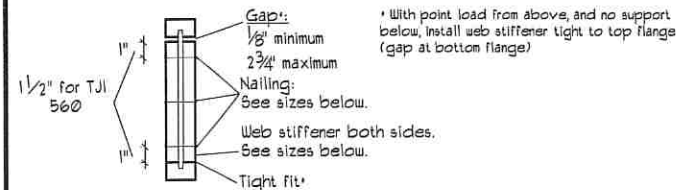

TJI Joist Series	Depth (in.)	Minimum Web Stiffener Size	Nailing Requirements	
			Type	Number Nails
110 210 230 & 360	All	3/8" x 2 5/16"	Bd (Ø113" x 2 1/2")	End
	All	3/4" x 2 5/16"		Intermediate
	All	7/8" x 2 5/16"		3
560	All	2x4	16d (Ø135" x 3 1/2")	

WEB STIFFENERS DETAIL

NOT TO SCALE

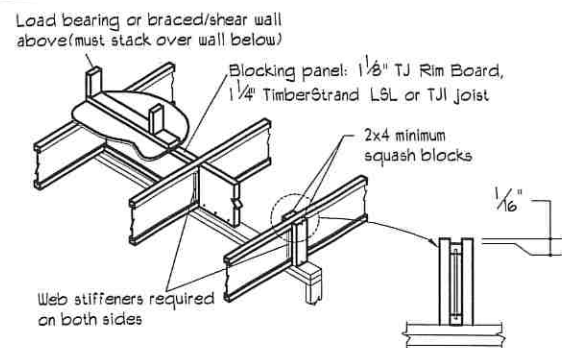

Blocking panels may be required with braced/shear walls above or below

FLOOR JOIST SOLID BLOCKING

NOT TO SCALE

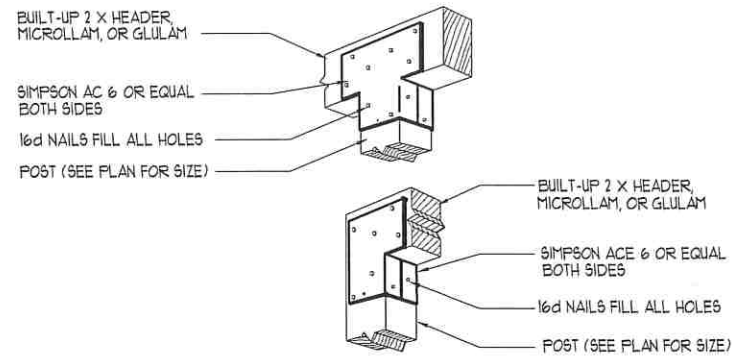

POST CAP DETAIL

NOT TO SCALE

INSTALL SIMPSON HANGER PER SPECIFICATIONS.

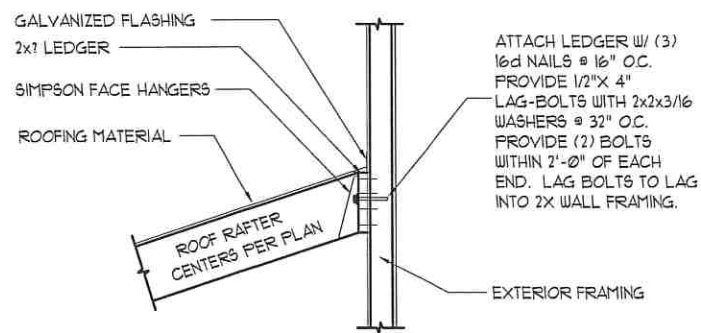

RAFTER ATTACHMENT

NOT TO SCALE

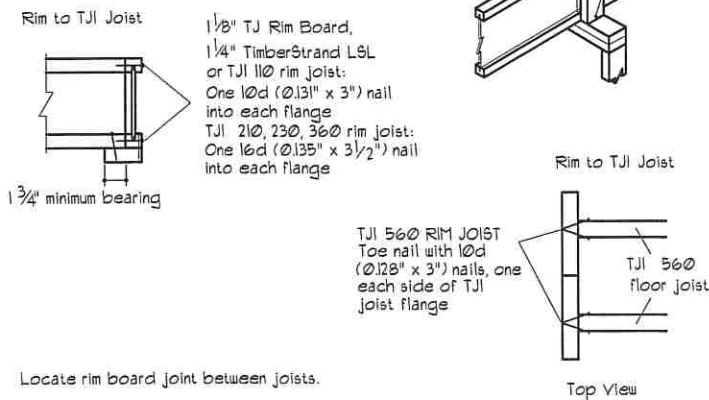
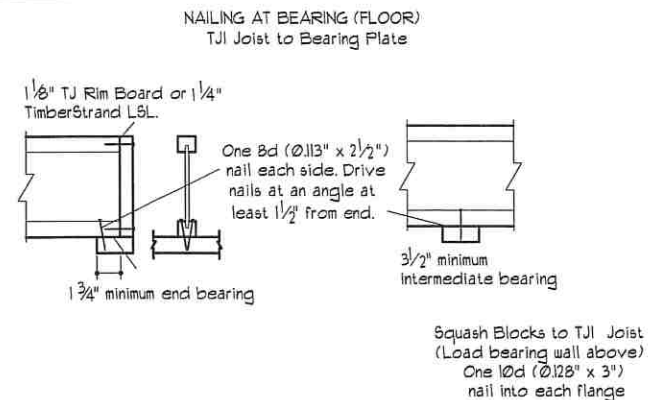

Locate rim board joint between joists.

FLOOR JOIST NAILING DETAILS

NOT TO SCALE

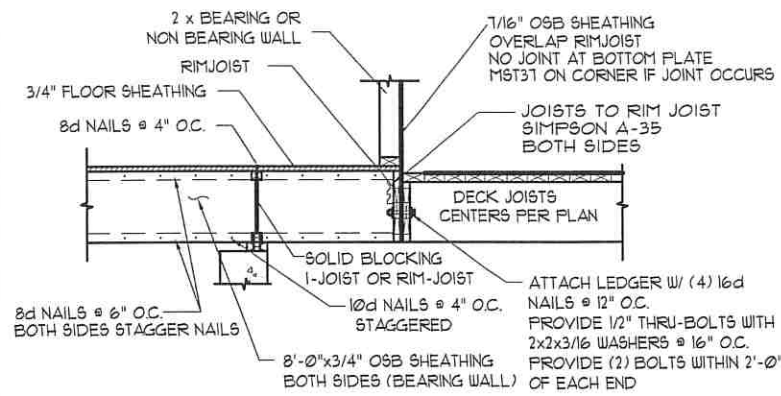

CANTILEVER / DECK DETAIL

NOT TO SCALE

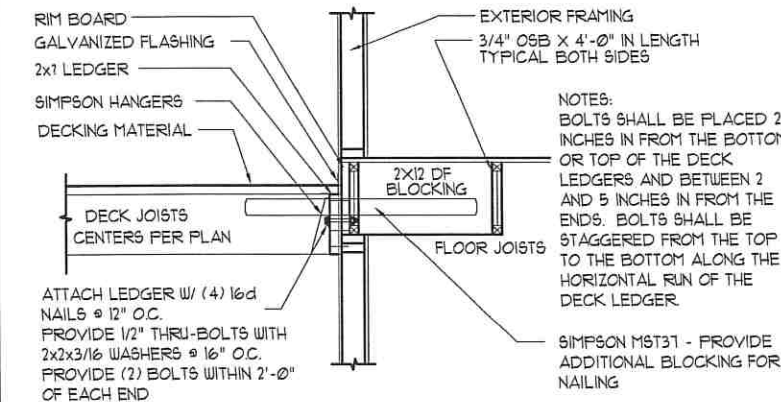

DECK ATTACHMENT

NOT TO SCALE

INSTALL SIMPSON HANGER PER SPECIFICATIONS.

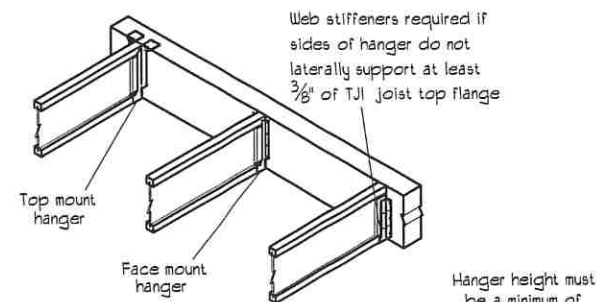

FLOOR JOIST HANGERS

NOT TO SCALE

Multiple-Member Connections for Top-Loaded Beams

Plyce Width	# of Plies	Fastener				Location
		Type ⁽¹⁾	Min. Length	# Rows	O.C. Spacing	
1 3/4"	2	10d nails	3"	3 ⁽²⁾	12"	One side
		12d-16d nails	3 3/4"	2 ⁽²⁾	12"	
	3	Screws	3 3/8" or 3 1/2"	2	24"	Both sides
		10d nails	3"	3 ⁽²⁾	12"	
1 3/4"	3	12d-16d nails	3 3/4"	2 ⁽²⁾	12"	Both sides
		Screws	3 3/8" or 3 1/2"	2	24"	
	4	10d nails ⁽³⁾	3"	3 ⁽²⁾	12"	One side (per ply)
		12d-16d nails ⁽³⁾	3 3/4"	2 ⁽²⁾	12"	
1 3/4"	4	Screws	5" or 6"	2	24"	Both sides
		Screws	6 3/4"	2	24"	

- (1) 10d nails are Ø128" diameter; 12d-16d nails are Ø148" - Ø162" diameter; screws are SDS, SDW, WS, or Truss-LCK-EWP.
- (2) An additional row of nails is required with depths of 14" or greater.
- (3) When connecting 4-ply members, nail each ply to the other and offset nail rows by 2" from the rows in the ply below.

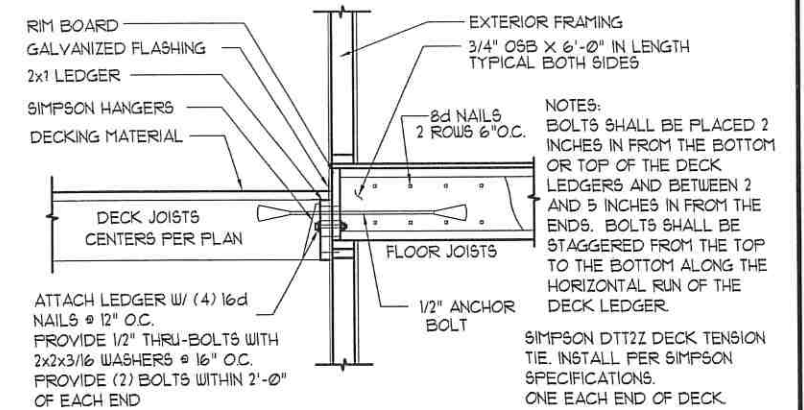

DECK ATTACHMENT

NOT TO SCALE

SIMPSON DTT2Z HOLDOWN - SPECIFICATIONS
INSTALLATION - USE ALL SPECIFIED FASTENERS. 1/2" ANCHOR BOLT, Ø-SDS 1/2"x1-1/2" SIMPSON SCREWS, STANDARD CUT WASHER INSTALLED BETWEEN THE NUT AND THE SEAT. SDS SCREWS INSTALL BEST WITH A LOW SPEED HIGH TORQUE DRILL WITH A 3/8" HEX. HEAD DRIVER. WHEN INSTALLING SCREWS PREVENT WOOD FROM SPLITTING.
HOLDOWNS-ANCHOR BOLT - DO NOT OVER-TORQUE, FINGER TIGHT PLUS 1/2 TO 1 TURN WITH A HAND WRENCH.
ATTACHMENT TO TJI FLOOR SYSTEM - INSTALL 3/4" OSB FLOOR SHEATHING BY 6'-0" WITH 8d COMMON NAILS TWO ROWS AT 6" O.C TO BOTH SIDES OF 1-JOISTS.

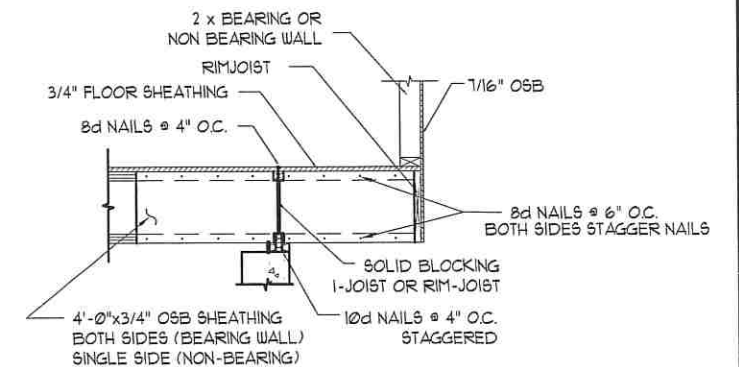

CANTILEVER DETAIL

NOT TO SCALE

When fasteners are required on both sides, stagger fasteners on the second side so they fall halfway between fasteners on the first side.

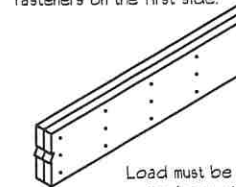

Load must be applied evenly across entire beam width. Otherwise, use connections for side-loaded beams.

Multiple pieces can be nailed or bolted together to form a header or beam of the required size, up to a maximum width of 7"



Karras Engineering
RESIDENTIAL / COMMERCIAL DESIGN & ENGINEERING
NATE KARRAS P.E. (801) 786-0849 email: kstomink@gmail.com

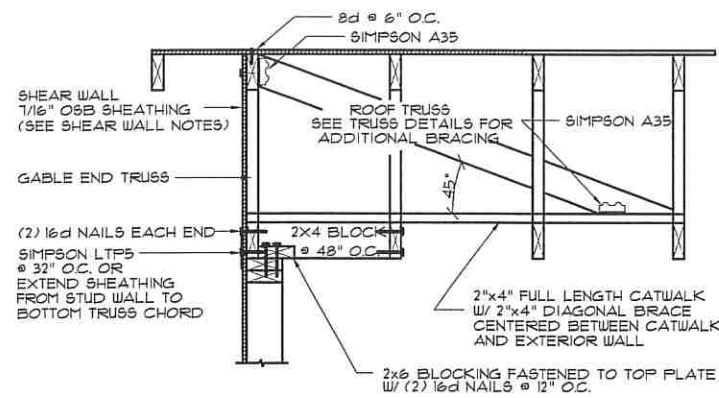

GABLE END DETAIL

NOT TO SCALE

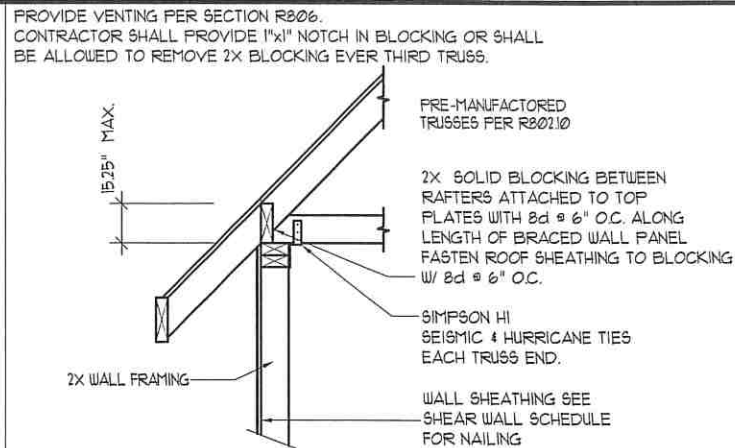

WALL TO ROOF TRUSS CONNECTION

NOT TO SCALE

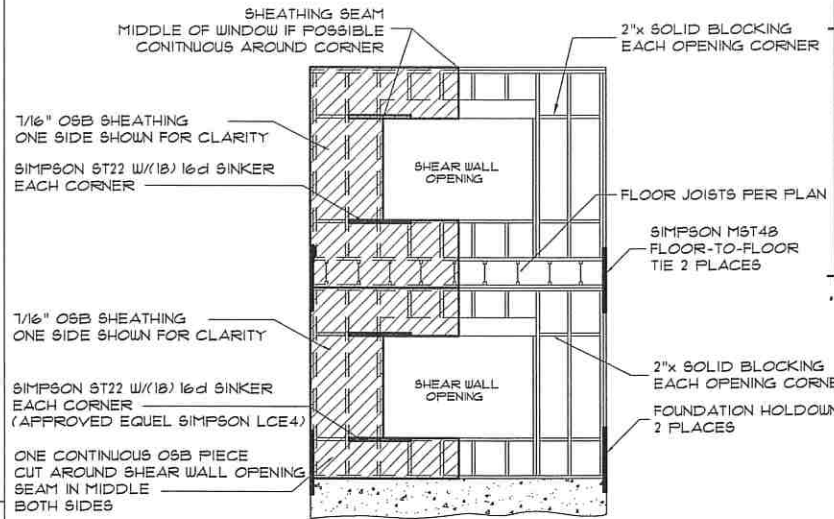

PERFORATED SHEAR WALL FRAMING DETAIL

NOT TO SCALE

SHEAR WALL SCHEDULE									
WIND	115 MPH	EXPOSURE	C	SEISMIC			ZONE = D2, R = 6		
MARK	OSB SHEATHING	SIZE	EDGE	FIELD	DIA	LENGTH	SPACING	NOTES	
SW-1	7/16"	8d	4"	12"	1/2"	10"	32"		
SW-2	7/16"	8d	4"	12"	1/2"	10"	32"		
SW-3	7/16"	8d	4"	12"	1/2"	10"	32"		
SW-4	7/16"	8d	4"	12"	1/2"	10"	32"		
SW-5	7/16"	8d	6"	12"				INTERIOR SHEARWALL	
BWP	7/16"	8d	3"	3"	5/8"	16"	TWO	NO STAPLES	
PSW	7/16"	8d	3"	12"	1/2"	10"	32"	NO STAPLES	

* FOUNDATION SILL PLATES TO ANCHORED WITH 3" X 3" X 0.225" THICK PLATE WASHERS

TABLE OF EQUIVALENT FASTENERS					
* GAUGE					
** PENETRATION					
(VALID FOR LATERAL LOADS ONLY)					
COMMON NAIL SPACING	STAPLE SPACING			T-NAIL SPACING	
	16"	15"	14"	13"	13"
	1 1/4"	1 1/4"	1 1/4"	1 1/4"	1 1/2"
*NO STAPLES EQUIVALENT FOR BWP & PSW SEE DETAILS FOR NAILING FOR BWP & PSW					
8d	4"	3 1/2"	4"	5"	4"
	6"	5"	6"	7"	5"
	8"	6 1/2"	8"	9 1/2"	7 1/2"
	10"	8 1/2"	10"	12"	10"
	12"	10"	12"	14 1/2"	14 1/2"
8d	4"	2 1/2"	3 1/2"	4"	3 1/2"
	6"	4"	6"	5"	4"
	8"	5 1/2"	6 1/2"	8"	6 1/2"
	10"	6 1/2"	8"	10"	8"
	12"	8"	10"	12"	9 1/2"

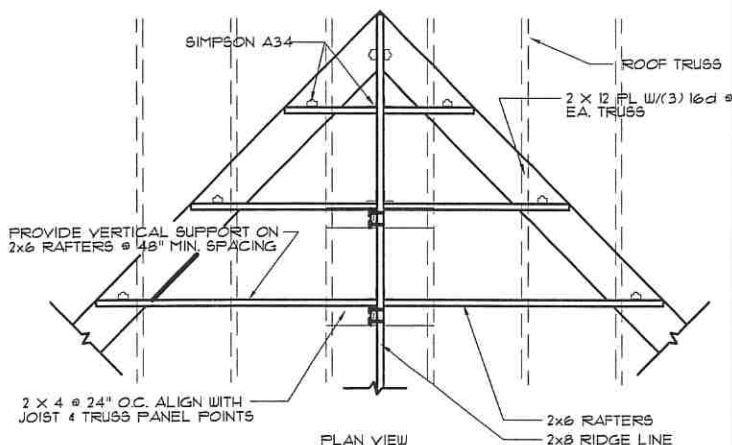

PLAN VIEW

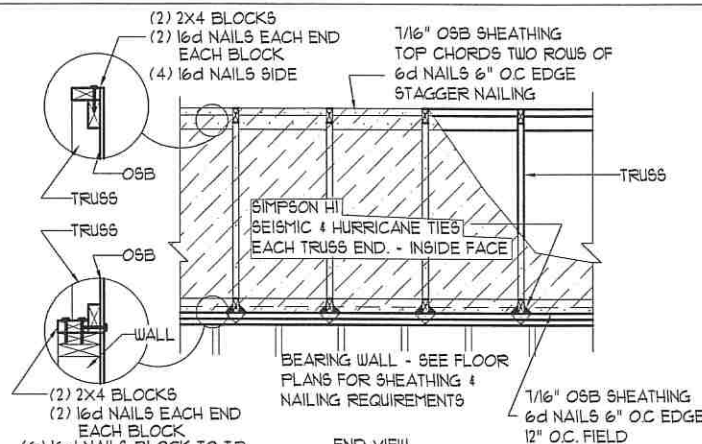

END VIEW

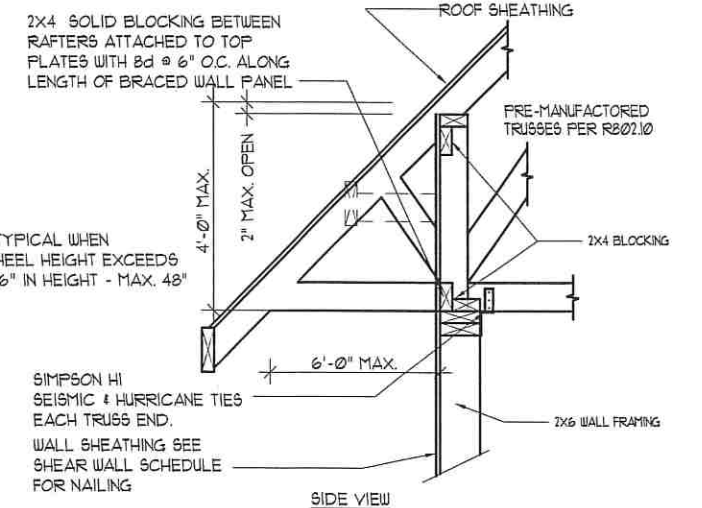

SIDE VIEW

WALL TO RAISED HEEL ROOF TRUSS CONNECTION

NOT TO SCALE

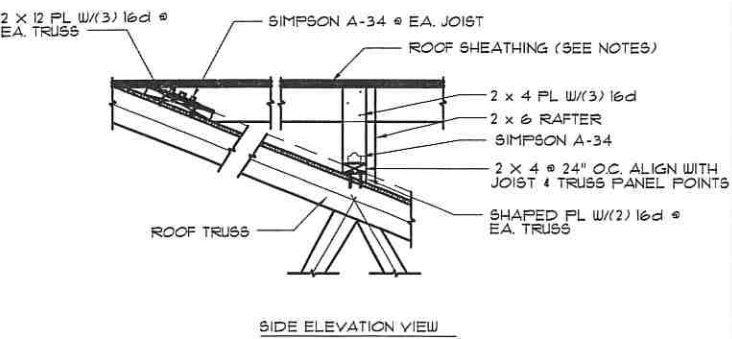

SIDE ELEVATION VIEW

OVERBUILD DETAIL

NOT TO SCALE

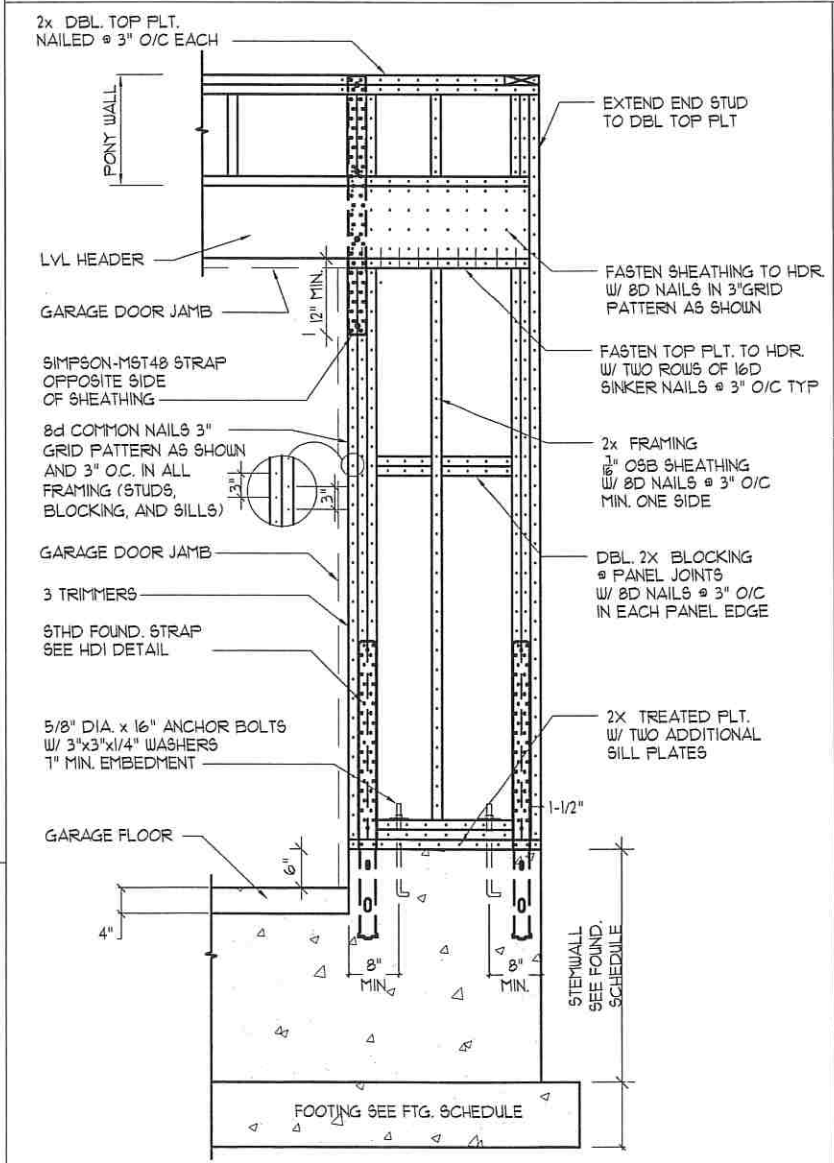

BRACED WALL PANEL DETAIL (BWP)

NOT TO SCALE

INSTALL SIMPSON HANGER PER SPECIFICATIONS.

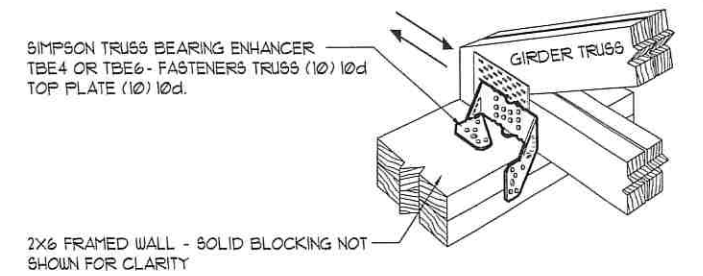

LATERAL BRACING - SIMPSON TBE4/6

NOT TO SCALE

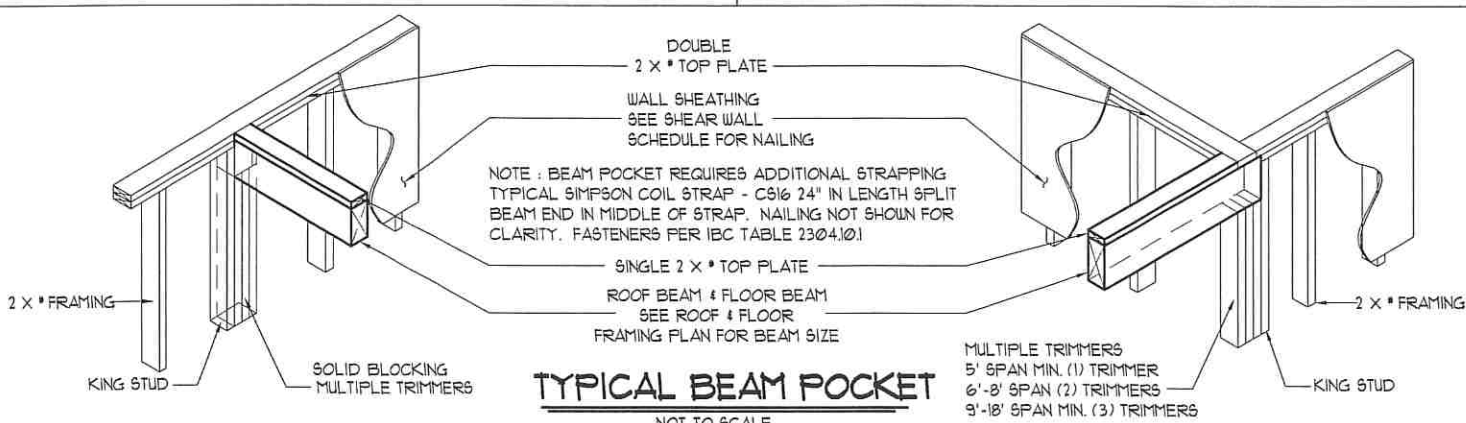

TYPICAL BEAM POCKET

NOT TO SCALE



Karras Engineering
RESIDENTIAL / COMMERCIAL DESIGN & ENGINEERING
NATE KARRAS P.E. (801) 786-0849 email: KustomNK@gmail.com

SCALE	1/8" = 1'-0"	1/4" = 1'-0"	1/2" = 1'-0"
PLAN NUMBER	11x17	24x36	
JAN 2019	S3		

2015 INTERNATIONAL BUILDING/RESIDENTIAL CODE

CONTRACTOR/OWNER SHALL COMPLY WITH BOTH IBC AND IRC BUILDING CODE REQUIREMENTS.

CONTRACTOR/OWNER SHALL COMPLY WITH UTAH ADMINISTRATIVE CODE RULE R196-56.

DESIGN CRITERIA

Table with 2 columns: Design Criteria (Governing Code, Seismic, Wind Loads, Roof Loads, Floor Loads, Deck Loads, Soil Bearing Pressure) and Values (2015 IRC, Zone D1, 5s=116.1, Fa=1.03, 115 MPH, etc.)

STRUCTURAL STEEL

- 1. FABRICATION AND CONSTRUCTION SHALL COMPLY WITH THE LATEST EDITION OF THE FOLLOWING CODES AND STANDARDS:
A. AMERICAN INSTITUTE OF STEEL CONSTRUCTION "SPECIFICATION FOR THE DESIGN, FABRICATION AND ERECTION OF STRUCTURAL STEEL FOR BUILDINGS, WITH " COMMENTARY.
B. AISC "CODE OF STANDARD PRACTICE" EXCLUDING THE FOLLOWING: SECTION 3.4, SECTION 4.4, SECTION 4.4I.
C. AISC "SPECIFICATIONS FOR STRUCTURAL JOINTS USING ASTM A325 OR A490 BOLTS"
D. AMERICAN WELDING SOCIETY (AWS) STRUCTURAL WELDING CODE (SPECIFIC ITEMS DO NOT APPLY WHEN THEY CONFLICT WITH AISC REQUIREMENTS).
E. AISC "SEISMIC PROVISION FOR STRUCTURAL STEEL BUILDINGS"

CONCRETE

- 1. ALL CONCRETE SHALL BE MIN. OF 3,000 PSI CONCRETE
2. TYPE I/II CEMENT COMPLYING WITH ASTM C-150 SHALL BE USED FOR ALL CONCRETE.
3. THE WATER/CEMENT RATIOS AND AIR ENTRAINMENT SHALL MEET THE REQUIREMENTS OF ACI 318.
4. REINFORCEMENT SHALL HAVE THE FOLLOWING CONCRETE COVER:
A. CAST IN PLACE CONCRETE. CLEAR COVER
B. CAST AGAINST PERMANENTLY EXPOSED TO EARTH. 3"
C. FORMED CONCRETE EXPOSED TO EARTH OR WEATHER:
1/2 THRU #8 BARS. 2"
#5 AND SMALLER BARS. 1-1/2"
D. CONCRETE NOT EXPOSED TO WEATHER OR IN CONTACT WITH GROUND:
SLABS, WALLS, JOISTS: #1 BARS AND SMALLER. 3/4"
BEAMS, COLUMNS: PRIMARY REINF, TIES, STIRRUPS, SPIRALS. 1 1/2"
E. REINFORCING MIN. LAP SPLICE - #4 BARS 24" - #5 BARS 30"

FOOTING & FOUNDATION R403 & R404

FOOTINGS AND FOUNDATION SHALL BE CONSTRUCTED IN ACCORDANCE TO SECTIONS R403 AND R404.

IT IS THE RESPONSIBILITY OF THE OWNER/CONTRACTOR TO VERIFY THE SITE AND GEOTECHNICAL CONDITIONS ARE IN COMPLIANCE WITH THE DESIGN CRITERIA LISTED ABOVE.

- 1. FOOTINGS HAVE BEEN DESIGNED TO THE SOIL BEARING PRESSURE SPECIFIED IN THE DESIGN CRITERIA.
2. ALL FOOTINGS ARE TO REST ON UNDISTURBED SOIL AND SHALL BE A MINIMUM OF 30", OR LOCAL FROST DEPTH, BELOW THE FINISH GRADE.
3. THE CONTRACTOR SHALL ENSURE THAT THE FOOTINGS ARE PROPERLY DRAINED AND THAT THE SOIL MOISTURE CONTENT MEETS THE IBC AND IRC REQUIREMENTS.
4. ANY ANOMALOUS SOIL CONDITION ENCOUNTERED DURING EXCAVATION, SUCH AS SLIPPAGE, HIGH MOISTURE CONTENT, IMPROPER DRAINAGE, ETC., SHALL BE BROUGHT TO THE ATTENTION OF THE ENGINEER BEFORE PROCEEDING.
5. COMPACT BACKFILL AGAINST FOUNDATION WALL TO 85% OF MODIFIED PROCTOR DRY DENSITY TO REDUCE SETTING OF FILL.
6. FOUNDATION ANCHOR BOLTS SHALL BE EMBEDDED IN AT LEAST 1" OF CONCRETE AND PLACED WITHIN 12" OF SILL PLATE END. IF MULTIPLE PLATES ARE USED, THE ANCHOR BOLTS SHALL EXTEND THROUGH ALL PLATES. THERE SHALL BE A MINIMUM OF 2 ANCHOR BOLT PER WALL SECTION. 3"x3"x0.223" SQUARE WASHERS SHALL BE USED BETWEEN ANCHOR BOLT AND PLATE. SEE CROSS SECTION FOR SIZE AND SPACING.
7. GRADE 60 REBAR SHALL BE USED FOR BOTH VERTICAL AND HORIZONTAL INSTALLATIONS.
8. HOLD-DOWNS SHALL BE EMBEDDED IN THE FOUNDATION PER MANUFACTURERS REQUIREMENTS. THE CONTRACTOR SHALL ENSURE THAT THE FASTENERS HOOK THE REBAR AND MEETS THE MINIMUM EDGE DISTANCE.

CONCRETE-ENCASED ELECTRODE E3608.12

AN ELECTRODE ENCASED BY AT LEAST 2 INCHES OF CONCRETE, LOCATED WITHIN AND NEAR THE BOTTOM OF A CONCRETE FOUNDATION OR FOOTING THAT IS IN DIRECT CONTACT WITH THE EARTH, CONSISTING OF AT LEAST 20 FEET OF ONE OR MORE BARE OR ZINC-GALVANIZED OR OTHER ELECTRICALLY CONDUCTIVE COATED STEEL REINFORCING BARS OR RODS OF NOT LESS THAN 1/2 INCH DIAMETER, OR CONSISTING OF AT LEAST 20 FEET OF BARE COPPER CONDUCTOR NOT SMALLER THAN 4 AWG SHALL BE CONSIDERED AS A GROUNDING ELECTRODE. REINFORCING BARS SHALL BE PERMITTED TO BE BONDED TOGETHER BY THE USUAL STEEL TIE WIRE OR OTHER EFFECTIVE MEANS.

FOOTINGS ON OR ADJACENT TO SLOPES R403.1.7

THE PLACEMENT OF BUILDINGS AND STRUCTURES ON OR ADJACENT TO SLOPES STEEPER THAN ONE UNIT VERTICAL IN THREE UNITS HORIZONTAL (33.3-PERCENT SLOPE) SHALL CONFORM TO SECTIONS R403.1.1 THROUGH R403.1.4.

BUILDING CLEARANCES FROM ASCENDING SLOPE SURFACES R403.1.7.1

IN GENERAL, BUILDINGS BELOW SLOPES SHALL BE SET A SUFFICIENT DISTANCE FROM THE SLOPE TO PROVIDE PROTECTION FROM SLOPE DRAINAGE, EROSION AND SHALLOW FAILURES.

FOOTING SETBACK FROM DESCENDING SLOPE SURFACES R403.1.7.2

FOOTINGS ON OR ADJACENT TO SLOPE SURFACES SHALL BE FOUNDED IN MATERIAL WITH AN EMBEDMENT AND SETBACK FROM THE SLOPE SURFACE SUFFICIENT TO PROVIDE VERTICAL AND LATERAL SUPPORT FOR THE FOOTING WITHOUT DETRIMENTAL SETTLEMENT.

FOUNDATION ELEVATION R403.1.7.3

ON GRADED SITES, THE TOP OF ANY EXTERIOR FOUNDATION SHALL EXTEND ABOVE THE ELEVATION OF THE STREET GUTTER AT POINT OF DISCHARGE OR THE INLET OF AN APPROVED DRAINAGE DEVICE A MINIMUM OF 12 INCHES (305 MM) PLUS 2 PERCENT.

STRUCTURAL FILL

STRUCTURAL FILL SHALL BE IMPORTED FILL MATERIAL.

IMPORTED FILL MATERIAL SHALL CONSIST OF WELL-GRADED SANDY GRAVELS TO SILTY SANDS WITH A MAXIMUM SIZE OF 4" AND 5 TO 20 PERCENT FINES (MATERIALS PASSING NO. 200 SIEVE). THE LIQUID LIMIT OF THE FINES SHALL NOT EXCEED 35% AND THE PLASTICITY INDEX SHALL BE BELOW 15.

CLEAN GRAVEL RANGING FROM FEA GRAVEL TO 4" WITH LESS THAN 5 PERCENT FINES AND SAND COMBINED MAY ALSO BE USED AS STRUCTURAL FILL.

ALL FILL SOILS SHALL BE FREE FROM TOPSOIL, HIGHLY ORGANIC MATERIAL, FROZEN SOIL, AND OTHER DELETERIOUS MATERIALS.

THE THICKNESS OF EACH LIFT SHALL BE APPROPRIATE FOR THE COMPACTION EQUIPMENT BEING USED. MAX. 6" LIFT FOR HAND COMPACTION. MAX. 8" FOR TRENCH COMPACTORS.

THE FULL THICKNESS OF EACH LIFT OF STRUCTURAL FILL SHALL BE COMPACTED TO AT LEAST 95 PERCENT OF THE MAXIMUM DRY DENSITY AS DETERMINED BY ASTM D-1557.

CLEAN GRAVEL FILL MAY BE PLACED IN MAX. 24" LIFTS. THE GRAVEL WILL NEED TO BE COMPACTED WITH AT LEAST 4 PASSES OF A VIBRATORY PLATE OR DRUM COMPACTOR.

WOOD - GENERAL FRAMING NOTES R502 & R602

WOOD FRAMING SHALL BE CONSTRUCTED IN ACCORDANCE TO SECTIONS R502 AND R602. FASTENERS SCHEDULE FOR STRUCTURAL MEMBERS PER TABLE R602.3(1).

- 1. FRAMING LUMBER SHALL BE #2 DOUGLAS FIR-LARCH OR BETTER UNLESS NOTED OTHER WISE.
2. ALL WOOD IN CONTACT WITH CONCRETE, MASONRY OR SOIL SHALL BE PRESURE TREATED OR BE REDWOOD.
3. ALL FRAMING ANCHORS, POST CAPS, HOLD DOWNS, COLUMN BASES, ETC. SHALL BE PROVIDED BY SIMPSON STRONG-TIE OR APPROVED EQUAL.
4. ALL WALLS SHALL HAVE A MINIMUM OF TWO TOP PLATES. SPLICES IN TOP PLATES SHALL BE STAGGERED A MINIMUM OF FOUR FEET FROM THE NEAREST SPLICE IN ADJOINING TOP PLATE.
5. ALL EXTERIOR AND LOAD BEARING WINDOW AND DOOR HEADERS SHALL HAVE (2) 2x10 DF No. 2 W/FILLER UNLESS NOTED OTHERWISE ON DRAWING.
6. ALL HEADERS SUPPORTING A GIRDER TRUSS SHALL BE A MIN. OF (2) 1-3/4"x9-1/2" LVLs UNLESS NOTED OTHERWISE ON DRAWING.
7. MULTIPLE BEAMS AND HEADERS SHALL BE NAILED TOGETHER ACCORDING TO DETAIL ON SHEET S2.
8. ALL POINT LOADS SHALL BE SOLID BLOCKED TO THE FOUNDATION. SEE SHEETS S1-S3.
9. MULTIPLE TRIMMERS - SEE TYPICAL BEAM POCKET SHEET 3.
10. USE SIMPSON OR EQUIVALENT HARDWARE TO CONNECT BEAMS 6' AND LONGER TO STUDS OR POSTS.
11. TALL WALL FRAMING SHALL BE BALLOON FRAMING - WALL FRAMING SHALL BE FULL HEIGHT AND CONTINUOUS FROM FLOOR TO CEILING. SEE TYPICAL WALL SECTION OR FLOOR PLANS FOR FRAMING MATERIAL AND SIZES.
12. MULTI LEVEL FRAMING - MULTI LEVEL FRAMING SHALL BE STAKE AND VERTICALLY ALIGNED TO CREATE DIRECT LOAD PATH.

FLOOR SHEATHING NOTES R503

- 1. TYPICAL FLOOR SHEATHING SHALL BE 3/4" T&G WAFFER BOARD NAILED W/ 8d NAILS @ 6" O.C. ON ALL EDGES, AND @ 12" O.C. ALONG INTERMEDIATE FRAMING MEMBERS.
2. SOLID JOIST BLOCKING REQUIRED AT ALL BEARING POINTS.
3. INSTALL FLOOR SHEATHING WITH FACE GRAIN AT RIGHT ANGLES TO FRAMING WITH END JOINTS STAGGERED.
4. USE DOUBLE FLOOR JOISTS UNDER ALL LOAD BEARING WALLS RUNNING PARALLEL WITH FLOOR JOISTS.
5. USE DOUBLE FLOOR JOISTS UNDER ALL SHEAR WALLS RUNNING PARALLEL WITH FLOOR JOISTS. NAIL BOTTOM PLATE TO JOISTS W/ 16d NAILS @ 3' O.C.
6. USE DOUBLE JOISTS TO SOLID BLOCK UNDER ALL SHEAR WALLS RUNNING PERPENDICULAR TO FLOOR JOISTS. NAIL BOTTOM PLATE TO BLOCKING W/ 16d NAILS @ 3' O.C.
7. FLOOR JOIST INSTALLATION PER MANUFACTURERS SPECIFICATIONS.

SHEAR WALL NOTES

- 1. AS A MINIMUM, ALL EXTERIOR WALL SHALL BE SHEATHED WITH 7/16" APA RATED C-D OR C-C SHEATHING AND NAILED WITH 8d's 4" O.C. EDGE AND 12" O.C. FIELD. IF NOT INDICATED ON PLANS. SEE SHEARWALL SCHEDULE.
2. SHEATHING SHALL EXTEND CONTINUOUS FROM MUD SILL TO TOP PLATE AND NAILED AT LEAST 1" O.C. ALONG SILL PLATE. SHEATHING SHALL EXTEND FROM FLOOR FRAMING TO HIGH ROOF FRAMING ON UPPER LEVEL EXTERIOR WALLS.
3. NAILS SHALL BE PLACED NOT LESS THAN 1/2" FROM EDGE OF PANEL AND DRIVEN FLUSH. NAIL SHALL NOT FRACTURE THE SURFACE OF THE SHEATHING.

WOOD TRUSS NOTES R202.10

PRE-MANUFACTURED TRUSSES SHALL CONFORM WITH SECTION R202.10 AND R502.11.

TRUSS MANUFACTURE SHALL PROVIDE DETAILS AND INSTRUCTION FOR HANDLING, INSTALLING, RESTRAINING, AND BRACING OF TRUSSES BEFORE AND AFTER CONSTRUCTION.

TRUSS DESIGN DRAWINGS SHALL BE PREPARED BY A REGISTERED PROFESSIONAL WHERE REQUIRED BY THE STATUES OF THE JURISDICTION IN WHICH THE PROJECT IS TO BE CONSTRUCTED IN ACCORDANCE WITH SECTION R106.1.

NO ALTERATIONS SHALL BE MADE TO THE TRUSSES OR THE TRUSS LAYOUT.

ANY CHANGES TO THE ROOF FRAMING PLAN SHALL BE BROUGHT TO THE ATTENTION OF THE DESIGN ENGINEER PRIOR TO MANUFACTURING AND OR CONSTRUCTION OF SAID TRUSSES.

TRUSS DESIGN DRAWINGS SHALL COMPLY WITH SECTION R502.11.4 & R202.10.1.

DEFERRED TRUSS DESIGN SHALL BE SUBMITTED TO KARRAS ENGINEERING AND THE BUILDING OFFICIAL FOR REVIEW AND GENERAL CONFORMANCE PRIOR TO INSTALLATION IN ACCORDANCE WITH IBC 1013.4.1.

CONTRACTOR SHALL PROVIDE MINIMUM 22" X 30" ATTIC ACCESS. - FIELD LOCATE PROVIDE WEATHER STRIPPING AROUND OPENING. R201.1.

THE CONTRACTOR SHALL BLOCK BETWEEN TRUSSES AND CONNECT EACH TRUSS TO WALL TOP PLATE WITH SIMPSON HI CONNECTORS.

GABLE ENDS SHALL HAVE SIMPSON STRONGTIE STRAPS @ 32" O.C. CONNECTING GABLE TRUSS TO WALL FRAMING.

TRUSSES TO BE INSTALLED PER MANUFACTURERS SPECIFICATIONS.

BLOCKING BETWEEN TRUSSES SHALL MATCH BOTTOM CHORD OF TRUSS.

BRACING - TRUSSES SHALL BE BRACED TO PREVENT ROTATION AND PROVIDE LATERL STABILITY.

ROOF SHEATHING NOTES R203

- 1. SHEATHING SHALL BE 7/16", 24/16, APA RATED SHEATHING. NAIL W/ 8d's @ 6" O.C. 3/8" FROM EDGE OF PANEL AT ALL PANEL ENDS, SUPPORTED EDGES, SHEARWALL TOPS, AND ALL BLOCKING. NAIL @ 12" O.C. ALONG INTERMEDIATE FRAMING MEMBERS. (5/8" SHEATHING WITH SNOW LOADS GREATER THAN 30 LBS)
2. LAY SHEATHING WITH FACE GRAIN AT RIGHT ANGLES TO FRAMING WITH STAGGERED END JOINTS.

BRICK VENEER SUPPORT / LINTELS R103.12.1

A MINIMUM 6 INCHES BY 4 INCHES BY 1/2 INCH STEEL ANGLE, WITH THE LONG LEG PLACED VERTICALLY, SHALL BE ANCHORED TO DOUBLE 2 INCHES BY 4 INCHES WOOD STUDS AT A MAXIMUM ON-CENTER SPACING OF 16 INCHES. ANCHORAGE OF THE STEEL ANGLE AT EVERY DOUBLE STUD SPACING SHALL BE A MINIMUM OF TWO 1/2" DIAMETER BY 4 INCH LAG SCREWS.

STEEL LINTELS SHALL BE SHOP COATED WITH RUST INHIBITIVE PAINT, EXCEPT FOR LINTELS MADE OF CORROSION-RESISTANT STEEL.

FASTENERS R317.3

FASTENERS AND CONNECTORS IN CONTACT WITH PRESERVATIVE - TREATED WOOD SHALL BE HOT DIPPEED ZINC-COATED GALVANIZED STEEL, STAINLESS STEEL, SILICON BRONZE OR COPPER. THE COATING WEIGHTS FOR ZINC-COATED FASTENERS SHALL BE IN ACCORDANCE WITH ASTM A 153. EXCEPTIONS 1/4" DIAMETER OR GREATER STEEL BOLTS.

DWELLING/GARAGE SEPERATION R302.6

STRUCTURAL MEMBERS SUPPORTING THE SEPARATION SHALL BE PROTECTED BY FIRE-RESISTIVE CONSTRUCTION. 1/2-INCH GYPSUM BOARD TYPICAL. 5/8-INCH TYPE X GYPSUM BOARD FOR HABITABLE ROOMS ABOVE THE GARAGE.

COMPLY WITH SECTION R302.6.

CEILING HEIGHT R305

HABITABLE SPACE, HALLWAYS, BATHROOMS, TOILET ROOMS, LAUNDRY ROOMS AND PORTIONS OF BASEMENTS CONTAINING THESE SPACES SHALL HAVE A CEILING HEIGHT OF NOT LESS THAN 7 FEET. BASEMENTS 6'-8" MIN. EXCEPTIONS UNDER BEAMS, GIRDERS, DUCTS OR OTHER OBSTRUCTIONS MAY PROJECT TO WITHIN 6'-4" OF THE FINISHED FLOOR.

WINDOW WELLS R310.2

WINDOW WELLS REQUIRED FOR EMERGENCY ESCAPE AND RESCUE SHALL HAVE HORIZ. DIMENSIONS THAT ALLOW THE DOOR OR WINDOW OF THE EMERGENCY ESCAPE AND RESCUE OPENING TO BE FULLY OPENED. THE HORIZONTAL DIMENSIONS OF THE WINDOW WELL SHALL PROVIDE A MINIMUM NET CLEAR AREA OF 9 SQUARE FEET WITH A MINIMUM HORIZONTAL PROJECTION AND WIDTH OF 36". WINDOW WELLS WITH A VERTICAL DEPTH GREATER THAN 44 INCHES SHALL BE EQUIPPED WITH A PERMANENTLY AFFIXED LADDER. COMPLY WITH SECTION R310.2.1

BASEMENT - WINDOW SILL HEIGHT R310.2.2

BASEMENT WINDOWS SHALL HAVE A SILL HEIGHT OF NO MORE THAN 44-INCHES ABOVE THE FLOOR. WHERE THE SILL HEIGHT IS BELOW GRADE THE WINDOW SHALL BE PROVIDED WITH A WINDOW WELL IN ACCORDANCE WITH R310.2.3.

WINDOW SILL HEIGHTS R312.2.1

IN DWELLING UNITS, WHERE THE OPENING OF AN OPERABLE WINDOW IS LOCATED MORE THAN 12 INCHES ABOVE THE FINISH GRADE OR SURFACE BELOW, THE LOWEST PART OF THE OPENING OF THE WINDOW SHALL BE A MINIMUM OF 24" INCHES ABOVE THE FINISHED FLOOR OF THE ROOM IN WHICH THE WINDOW IS LOCATED. OPERABLE SECTIONS OF WINDOWS SHALL NOT PERMIT OPENINGS THAT ALLOW PASSAGE OF A 4 INCH DIA. SPHERE WHERE SUCH OPENINGS ARE LOCATED WITHIN 24 INCHES OF THE FINISHED FLOOR.

MEANS OF EGRESS R311

THERE SHALL BE A LANDING OR FLOOR ON EACH SIDE OF EACH EXTERIOR DOOR. THE WIDTH OF EACH LANDING SHALL NOT BE LESS THAN THE DOOR SERVED. EVERY LANDING SHALL HAVE A MINIMUM DIMENSION OF 36 INCHES MEASURED IN THE DIRECTION OF TRAVEL. EXTERIOR LANDINGS SHALL BE PERMITTED TO HAVE A SLOPE NOT TO EXCEED 0.25 UNIT VERTICAL IN 12 UNITS. (2%)

GUARDS AND WINDOW FALL PROTECTION R312

GUARDS SHALL BE LOCATED ALONG OPEN-SIDED WALKING SURFACES, INCLUDING STAIRS, RAMPS AND LANDINGS, THAT ARE LOCATED MORE THAN 30 INCHES MEASURED VERTICALLY TO THE FLOOR OR GRADE BELOW AT ANY POINT 36 INCHES HORIZONTALLY TO THE EDGE OF THE OPEN SIDE.

OPENING LIMITATIONS - REQUIRED GUARDS SHALL NOT HAVE OPENINGS FROM THE WALKING SURFACE TO THE REQUIRED GUARD HEIGHT THAT ALLOW PASSAGE OF A SPHERE 4 INCHES IN DIAMETER.

SMOKE ALARMS R314

SMOKE ALARMS SHALL BE IN ACCORDANCE WITH SECTION R314.

ALL SMOKE ALARMS SHALL BE LISTED IN ACCORDANCE WITH UL 217 AND INSTALLED IN ACCORDANCE WITH THE PROVISIONS OF THIS CODE AND THE HOUSEHOLD FIRE WARNING EQUIPMENT PROVISIONS OF NFPA 12.

SMOKE ALARMS SHALL BE INSTALLED IN THE FOLLOWING LOCATIONS: IN EACH SLEEPING ROOM, OUTSIDE EACH SEPARATE SLEEPING AREA IN THE IMMEDIATE VICINITY OF THE BEDROOMS, ON EACH ADDITIONAL STORY OF THE DWELLING, INCLUDING BASEMENTS AND UNINHABITABLE ATTICS.

WHEN MORE THAN ONE SMOKE ALARM IS REQUIRED TO BE INSTALLED WITHIN AN INDIVIDUAL DWELLING UNIT THE ALARM DEVICES SHALL BE INTERCONNECTED IN SUCH A MANNER THAT THE ACTUATION OF ONE ALARM WILL ACTIVATE ALL OF THE ALARMS IN THE INDIVIDUAL UNIT.

CARBON MONOXIDE ALARMS R315

CARBON MONOXIDE ALARMS SHALL BE IN ACCORDANCE WITH SECTION R315.

AN APPROVED CARBON MONOXIDE ALARM SHALL BE INSTALLED ON EACH HABITABLE LEVEL WITHIN WHICH FUEL-FIRED APPLIANCES ARE INSTALLED AND IN DWELLINGS UNITS THAT HAVE ATTACHED GARAGES.

SINGLE STATION CARBON MONOXIDE ALARMS SHALL BE LISTED AS COMPLYING WITH UL 2034 AND SHALL BE INSTALLED IN ACCORDANCE WITH THIS CODE AND NFPA 720.

GLAZING R308

1. GLAZING IN DOORS AND ENCLOSURES FOR HOT TUBS, WHIRLPOOLS, SAUNAS, STEAM ROOMS, BATHTUBS AND SHOWERS. GLAZING IN ANY PART OF A BUILDING WALL ENCLOSING THESE COMPARTMENTS WHERE THE BOTTOM EXPOSED EDGE OF THE GLAZING IS LESS THAN 60 INCHES MEASURED VERTICALLY ABOVE ANY STANDING OR WALKING SURFACE.

2. GLAZING IN AN INDIVIDUAL FIXED OR OPERABLE ADJACENT TO A DOOR WHERE THE NEAREST VERTICAL EDGE IS WITHIN A 24-INCH ARC OF THE DOOR IN A CLOSED POSITION AND WHOSE BOTTOM EDGE IS LESS THAN 60 INCHES ABOVE THE FLOOR OR WALKING SURFACE.

3. GLAZING IN WALLS ENCLOSING STAIRWAY LANDING OR WITHIN 60 INCHES OF THE TOP AND BOTTOM OF STAIRWAYS WHERE THE BOTTOM EDGE OF THE GLASS IS LESS THAN 60 INCHES ABOVE THE WALKING SURFACE.

WEATHER-RESISTANT BARRIER R103.6.3

WEATHER-RESISTANT BARRIERS SHALL BE INSTALLED AS REQUIRED IN SECTION R103.2 AND, WHERE APPLIED OVER WOOD-BASED SHEATHING, SHALL INCLUDE A WEATHER-RESISTANT VAPOR PERMEABLE BARRIER WITH A PERFORMANCE AT LEAST EQUIVALENT TO TWO LAYERS OF GRADE D PAPER.

WEEP SCREDS R103.6.2.1

A MINIMUM 0.0135-INCH (NO. 26 GALVANIZED SHEET GAGE), CORROSION-RESISTANT WEEP SCREEN OR PLASTIC WEEP SCREED, WITH A MINIMUM VERTICAL ATTACHMENT FLANGE OF 3-1/2 INCHES SHALL BE PROVIDED AT OR BELOW THE FOUNDATION PLATE LINE ON EXTERIOR STUD WALLS IN ACCORDANCE WITH ASTM C 926. THE WEEP SCREED SHALL BE PLACED A MINIMUM OF 4 INCHES ABOVE THE EARTH OR 2" ABOVE PAVED AREAS AND SHALL BE OF TYPE THAT WILL ALLOW TRAPPED WATER TO DRAIN TO THE EXTERIOR OF THE BUILDING. THE WEATHER-RESISTANT BARRIER SHALL LAP THE ATTACHMENT FLANGE. THE EXTERIOR LATH SHALL COVER AND TERMINATE ON THE ATTACHMENT FLANGE OF THE WEEP SCREED.

ARC-FAULT PROTECTION E3902.12

ALL BRANCH CIRCUITS THAT SUPPLY 120-VOLT, SINGLE PHASE, 15- AND 20-AMPERE OUTLETS IN FAMILY ROOMS, DINING ROOMS, LIVING ROOMS, PARLORS, LIBRARIES, DENS, BEDROOMS, SUN-ROOMS, RECREATION ROOMS, CLOSETS, HALLWAYS, OR SIMILAR ROOMS OR AREAS SHALL BE PROTECTED BY A COMBINATION TYPE ARC-FAULT CIRCUIT INTERRUPTER INSTALLED TO PROVIDE PROTECTION OF THE ENTIRE BRANCH CIRCUIT.

TUB AND SHOWER R301

BATHTUB AND SHOWER SPACES - R301.2

BATHTUB AND SHOWER FLOORS AND WALLS ABOVE BATHTUBS WITH INSTALLED SHOWER HEADS AND IN SHOWER COMPARTMENTS SHALL BE FINISHED WITH A NONABSORBANT SURFACE. SUCH WALL SURFACES SHALL EXTEND TO HEIGHT OF NOT LESS THAN 6 FEET ABOVE THE FLOOR.

LIMIT WATER TEMPERATURE TO A MAX. 120° F. PER SECTION P210B.3 AND P213.3.

JETTED TUB ACCESS - 12"x12" ACCESS PER IRC P212.0.

GENERAL NOTES

- 1. CONTRACTOR IS TO VERIFY DESIGN, DIMENSIONS AND NOTES PRIOR TO BEGINNING OF CONSTRUCTION.
2. ALL WORK IS TO BE DONE UNDER THE SUPERVISION OF A LICENSED CONTRACTOR.
3. ALL WORK IS TO BE DONE UNDER LOCAL AND STATE BUILDING CODES.
4. ELECTRICAL SHALL BE PER NATIONAL ELECTRIC CODE, LATEST EDITIONS.
5. HEATING/MECHANICAL WORK SHALL BE PER APPLICABLE CODES, LATEST EDITIONS.



Karras Engineering
RESIDENTIAL / COMMERCIAL DESIGN & ENGINEERING
NATE KARRAS P.E. (801) 786-0849 email: KustomNK@gmail.com
SCALE
1/8" = 1'-0" 11x17
1/4" = 1'-0" 24x36
PLAN NUMBER
JAN 2019 S4

NOTE THIS PLAN IS THE PROPERTY OF KUSTOM HOUSE PLANS DO NOT COPY WITHOUT WRITTEN PERMISSION

WEATHER RESISTIVE BARRIER (RT03.2)

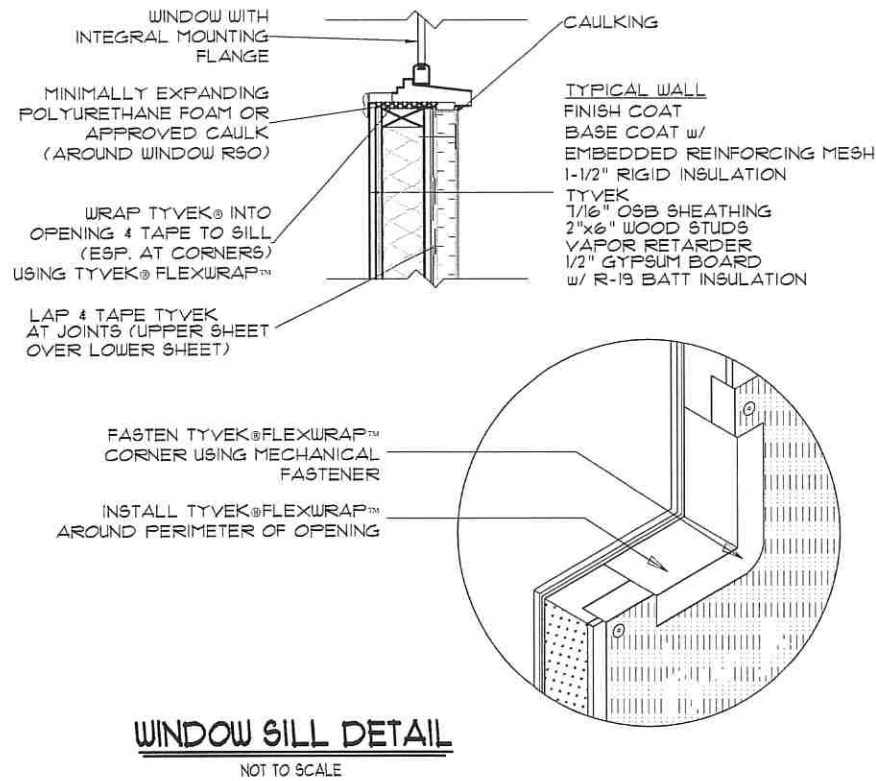

WINDOW SILL DETAIL
NOT TO SCALE

GENERAL NOTES

- SEAL ALL TYVEK JOINTS AND PENETRATIONS WITH APPROVED TAPE (ex. DUPONT CONTRACTOR TAPE)
- FASTEN TYVEK TO SHEATHING WITH LARGE HEAD NAILS OR USE NAILS WITH LARGE PLASTIC WASHER HEADS (ex. DUPONT WRAPCAPS)
- LOCAL LAWS, ZONING, AND BUILDING CODES VARY AND THEREFORE GOVERN OVER MATERIAL SELECTION AND DETAILING SHOWN BELOW
- INSTALL EIFS ACCORDING TO MANUFACTURER'S WRITTEN INSTRUCTIONS

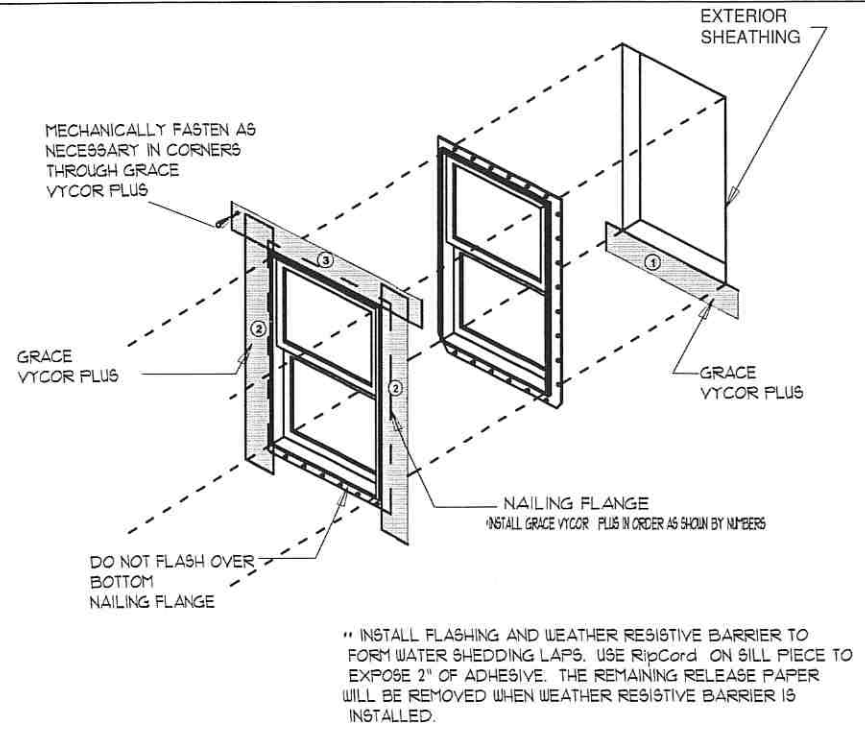

WINDOW / DOOR HEAD DETAIL
NOT TO SCALE

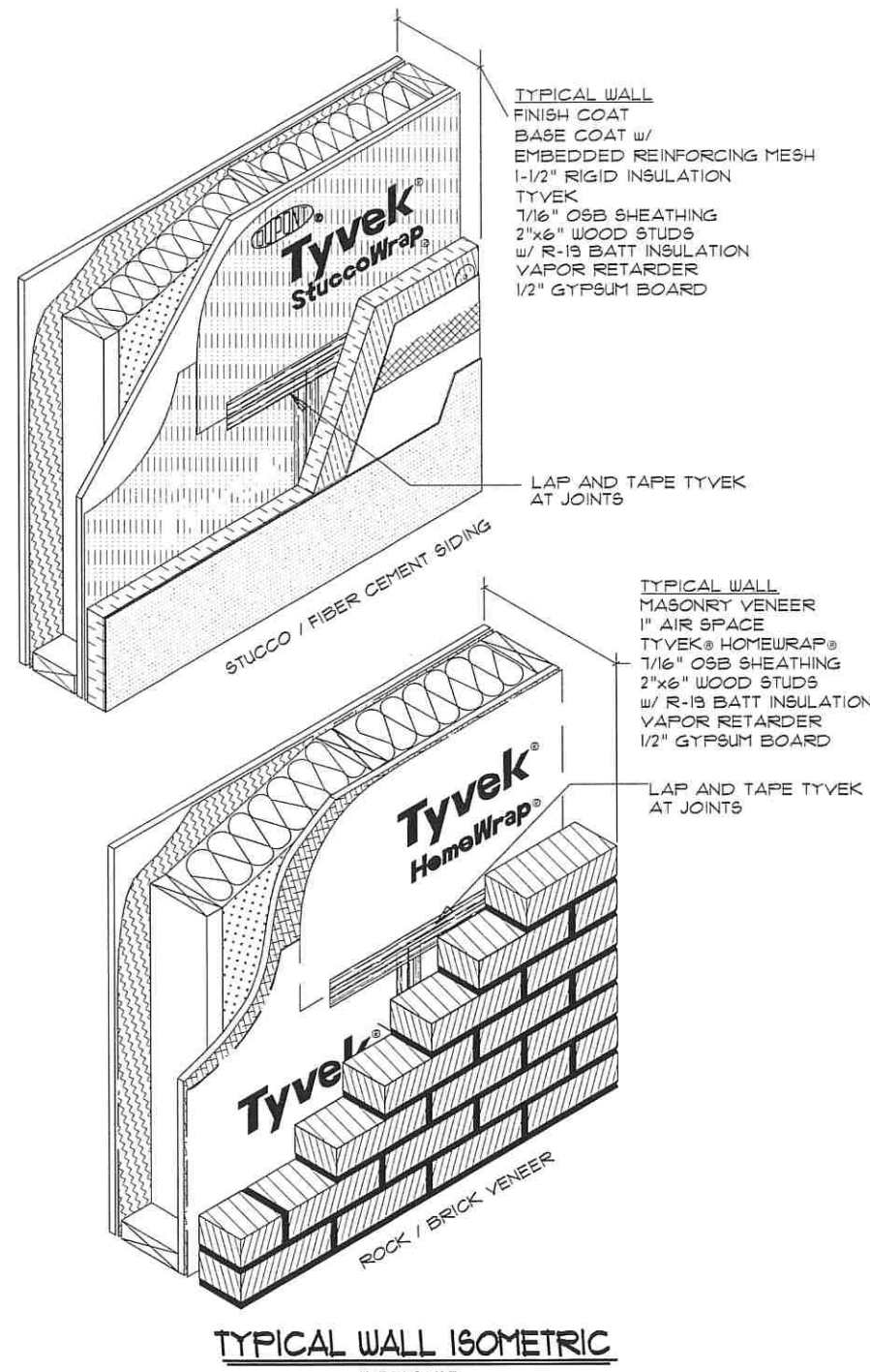

TYPICAL WALL ISOMETRIC
NOT TO SCALE

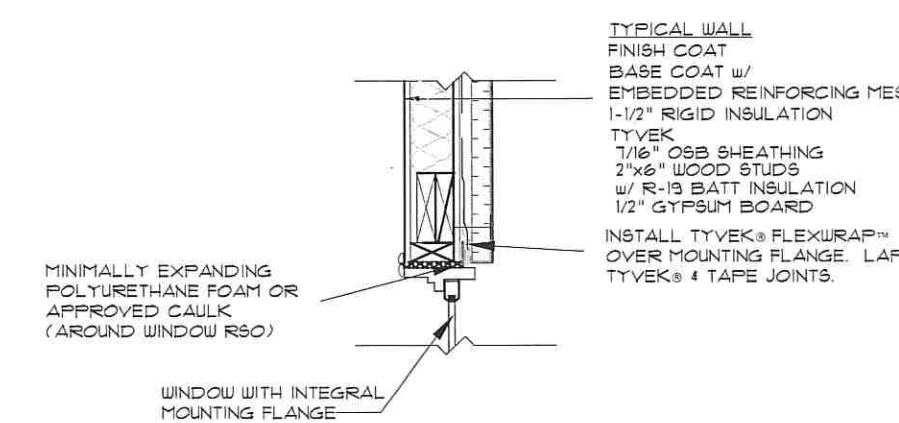

WINDOW / DOOR HEAD DETAIL
NOT TO SCALE

2015 IECC REQUIREMENTS FOR UTAH HOMES

ZONE	WINDOWS		INSULATION				FOUNDATION		
	FENESTRATION U-FACTOR	GLAZED FENESTRATION SHGC	CEILING R-VALUE	WOOD FRAME WALL R-VALUE	MASS WALL R-VALUE	FLOOR R-VALUE	BASEMENT WALL R-VALUE	SLAB R-VALUE AND DEPTH	CRAWL SPACE WALL R-VALUE
ZONE 6	0.32	NR	49	20 + 5 OR 13 + 10	15/20	30	15/20	10, 4 FT	15/19
ZONE 5	0.32	NR	49	20 OR 13 + 5	13/17	30	13/17	10, 2 FT	15/19
ZONE 3	0.32	0.25	38	20 OR 13 + 5	8/13	19	8/13	0	5/13
ZONE 3	WASHINGTON		ZONE 5	BEAVER, DAVIS, EMERY, GARFIELD, GRAND, IRON, JUAB, KANE,					
ZONE 5	MILLARD, BLUTE, SALT LAKE, SAN JUAN, SANPETE, SEVIER, TOOELE UTAH, WAYNE, WEBER								
ZONE 6	BOX ELDER, CACHE, CARBON, DAGGETT, DUCHESNE, MORGAN, RICH, SUMMIT, UTAH, WASATCH								

FENESTRATION (IECC SECTIONS R303.1.3, R402.3, R402.5)

FENESTRATION (INCLUDING ALL WINDOWS AND DOORS) AND SKYLIGHT U-FACTORS ARE MAXIMUM ACCEPTABLE LEVELS. THE GLAZED FENESTRATION SHGC MAXIMUMS APPLY TO ALL WINDOWS, SKYLIGHTS AND GLAZED DOORS. AN AREA-WEIGHTED AVERAGE OF FENESTRATION PRODUCTS IS PERMITTED TO SATISFY THESE REQUIREMENTS. (SEE IECC SECTION R402.3)

WINDOW, DOOR AND SKYLIGHT U-FACTORS AND SHGC'S MUST BE DETERMINED BY AN ACCREDITED, INDEPENDENT LABORATORY, AND LABELED AND CERTIFIED BY THE MANUFACTURER, IN ACCORDANCE WITH A NATIONAL FENESTRATION RATING COUNCIL (NFR) RATING. PRODUCTS WITHOUT AN NFR LABEL MUST USE THE DEFAULT VALUES IN IECC SECTION R303.1.3

WINDOWS, SKYLIGHTS, AND SLIDING GLASS DOORS MUST BE LABELED TO SHOW THAT THEY MEET THE IECC'S AIR INFILTRATION REQUIREMENTS.

UP TO 15 SQUARE FEET OF GLAZED FENESTRATION IS PERMITTED TO BE EXEMPT FROM THE U-FACTOR AND SHGC REQUIREMENTS. ONE SIDE HINGED OPAQUE DOOR ASSEMBLY UP TO 24 SQUARE FEET IS EXEMPT FROM THE FENESTRATION U-FACTOR REQUIREMENTS IN THERMALLY ISOLATED SUNROOMS. (IECC SECTION R402.3.5)

INSULATION (IECC SECTIONS R303.1.4 AND R402.2)

INSULATION R-VALUES ARE MINIMUM ACCEPTABLE LEVELS AND MUST BE DETERMINED ACCORDING TO FEDERAL TRADE COMMISSION RULE.

R-VALUES FOR WALLS REPRESENT THE SUM OF CAVITY INSULATION PLUS INSULATED SHEATHING, IF ANY. THE SECOND R-VALUE FOR MASS WALLS APPLIES WHEN MORE THAN HALF THE INSULATION IS ON THE INTERIOR OF THE MASS WALL.

THE INSULATION FOR BASEMENT WALLS MUST BE FROM THE TOP OF THE WALL DOWN 10 FEET BELOW GRADE OR TO THE BASEMENT FLOOR, WHICHEVER IS LESS. BASEMENT WALL INSULATION IS NOT REQUIRED IN WARM-HUMID LOCATIONS AS DEFINED IN IECC FIGURE R301.1. INSULATION REQUIREMENTS FOR CRAWL SPACE WALLS ARE FURTHER SPECIFIED IN IECC SECTION R402.2.11

FLOOR INSULATION MUST BE INSTALLED TO MAINTAIN CONTACT WITH THE UNDERSIDE OF THE SUBFLOOR DECKING. REFER TO THE CODE FOR DETAILS ALLOWING INSULATION TO BE INSTALLED ON THE LOWER SIDE OF THE CEILING CAVITY.

ACCESS DOORS FROM CONDITIONED SPACES (EG. ATTICS AND CRAWL SPACES) TO UNCONDITIONED SPACES SHALL BE WEATHER STRIPPED AND INSULATED TO A LEVEL EQUIVALENT TO THE INSULATION ON THE SURROUNDING SURFACES. VERTICAL ACCESS DOORS ARE PERMITTED TO MEET THE FENESTRATION REQUIREMENTS.

INSULATION REQUIREMENTS FOR SLAB ON GRADE FLOORS ARE FURTHER SPECIFIED IN IECC SECTION R402.2.10. R-5 SHALL BE ADDED TO THE REQUIRED SLAB EDGE R-VALUES FOR HEATED SLABS.

SPECIAL INSULATION EXCEPTIONS RELATED TO CEILINGS WITH OR WITHOUT ATTIC SPACES, MASONRY VENEER AND THERMALLY ISOLATED SUNROOMS ARE SET FORTH IN IECC SECTION R402.

DUCTS (IECC SECTION R403.3)

DUCTS MUST BE TESTED AND VERIFIED TO HAVE TOTAL LEAKAGE OF NO MORE THAN 4cfm/100 SQ. FT. (OR 3cfm IF AIR HANDLER IS NOT INSTALLED), EXCEPT WHERE AIR HANDLER AND ALL DUCTS ARE LOCATED INSIDE CONDITIONED SPACE. AIR HANDLERS AND FILTER BOXES MUST ALSO BE PROPERLY SEALED.

SUPPLY AND RETURN DUCTS SHALL BE SEALED AND INSULATED AS FOLLOWS:

DUCT LOCATION	LESS THAN 3 INCHES IN DIAMETER	GREATER THAN 3 INCHES IN DIAMETER
ATTIC	R-6	R-8
OTHER PORTIONS OF THE BUILDING	R-4.2	R-6
COMPLETELY INSIDE CONDITIONED SPACE	EXEMPT	EXEMPT

AIR SEALING (IECC SECTION R402.4)

THE BUILDING ENVELOPE IS REQUIRED TO BE PROPERLY SEALED AND TESTED, AND VERIFIED AS HAVING AN AIR LEAKAGE RATE NO HIGHER THAN 3 ACH AT 0.2 INCH WG. (50 PASCAL) IN CLIMATE ZONES 3, 5 AND 6. RECESSED LIGHTING MUST ALSO BE SEALED TO LIMIT AIR LEAKAGE.

DOCUMENTATION (IECC SECTIONS R103, R303.3, R401.3)

THE APPROPRIATE CONSTRUCTION DOCUMENTS AND PREVENTATIVE MAINTENANCE INFORMATION MUST BE PROVIDED, ALONG WITH A PERMANENT CERTIFICATE LISTING CERTAIN INSULATION, WINDOW AND HVAC PERFORMANCE INFORMATION.

SYSTEMS (IECC SECTION R403)

HVAC SYSTEM MUST BE PROPERLY SIZED IN ACCORDANCE WITH ACCA MANUAL S BASED ON BUILDING LOADS CALCULATED IN ACCORDANCE WITH ACCA MANUAL J OR OTHER APPROVED METHODOLOGIES. NEW OR REPLACEMENT HEATING AND COOLING EQUIPMENT MUST MEET OR EXCEED FEDERAL MINIMUM EFFICIENCY REQUIREMENTS FOR GEOGRAPHIC LOCATION IN WHICH IT IS INSTALLED.

TEMPERATURE CONTROLS MUST BE INSTALLED, INCLUDING A PROGRAMMABLE THERMOSTAT WHERE REQUIRED.

MECHANICAL SYSTEM PIPING MUST BE INSULATED TO A MINIMUM OF R-3. HOT WATER PIPING MUST BE INSULATED TO R-3, WITH CERTAIN EXCEPTIONS.

SPECIFIC REQUIREMENTS APPLY TO CIRCULATING HOT WATER SYSTEMS, MECHANICAL VENTILATION, SNOW MELT SYSTEMS, AND POOLS.

LIGHTING (IECC SECTIONS R202 AND R404.1)

A MINIMUM OF 75% OF LAMPS IN PERMANENTLY INSTALLED FIXTURES MUST BE HIGH-EFFICACY AS DEFINED IN THE IECC.



Karras Engineering
RESIDENTIAL / COMMERCIAL DESIGN & ENGINEERING
NATE KARRAS P.E. (801) 786-0849 email: KustonnK@gmail.com