

NETWORK VISION MMBS LAUNCH  
**HUNTSVILLE**  
**SL54XC068**  
**MONOPOLE**  
 750 N. 7200 E  
 HUNTSVILLE, UT 84137  
 COUNTY OF WEBER  
 LATITUDE: 41.271340 / 41° 16' 16.824" N (NAD 83)  
 LONGITUDE: -111.771219 / 111° 46' 16.3884" W (NAD 83)  
**UTAH MARKET**



**GENERAL DYNAMICS**  
 Information Technology

1171 WEST 2400 SOUTH  
 WEST VALLEY CITY, UT 84119

**Technology Associates  
 EC Inc.**

**UTAH MARKET OFFICE**  
 9847 SOUTH 500 WEST  
 SANDY, UTAH 84070  
 (801) 463-1020

ALL WORK AND MATERIALS SHALL BE PERFORMED AND INSTALLED IN ACCORDANCE WITH THE CURRENT EDITIONS OF THE FOLLOWING CODES AS ADOPTED BY THE LOCAL GOVERNING AUTHORITIES. NOTHING IN THESE PLANS IS TO BE CONSTRUCTED TO PERMIT WORK NOT CONFORMING TO THESE CODES.

BUILDING/DWELLING CODE IBC 2009 (UTAH UNIFORM BUILDING STANDARD ACT RULES, RULE R156-56-701)

STRUCTURAL CODE IBC 2009 (UTAH UNIFORM BUILDING STANDARD ACT RULES, RULE R156-56-701)  
 PLUMBING CODE IPC 2009 (UTAH UNIFORM BUILDING STANDARD ACT RULES, RULE R156-56-701)  
 MECHANICAL CODE IMC 2009 (UTAH UNIFORM BUILDING STANDARD ACT RULES, RULE R156-56-701)  
 ELECTRICAL CODE NEC 2008 (UTAH UNIFORM BUILDING STANDARD ACT RULES, RULE R156-56-701)  
 FIRE/LIFE SAFETY CODE IFC 2009 (NFPA 101 LIFE SAFETY CODE 2006)

ACCESSIBILITY REQUIREMENTS:  
 FACILITY IS UNMANNED AND NOT FOR HUMAN HABITATION. HANDICAPPED ACCESS REQUIREMENTS ARE NOT REQUIRED IN ACCORDANCE WITH THE 2009 IBC BUILDING CODE.

**CODE BLOCK**



**APPLICANT:**  
 GENERAL DYNAMICS ON BEHALF OF SPRINT  
 1171 WEST 2400 SOUTH  
 WEST VALLEY, UT 84119  
 CONTACT: MATTHEW T. SCHUTJER  
 PHONE #: (801) 736-5096

**PROPERTY INFORMATION:**  
 PROPERTY OWNER: FRANK CLAWSON  
 ADDRESS: 6862 E. BONANZA RD.  
 LAS VEGAS, NV 89110  
 CONTACT: VINCE STOUT  
 PHONE #: 303-573-3332

**TOWER OWNER:** AT&T WIRELESS  
**SITE ID #:** HUNTSVILLE UT2-045

**ZONING CLASSIFICATION:** AV-3  
**CONSTRUCTION TYPE:** V  
**OCCUPANCY:** B  
**JURISDICTION:** WEBER COUNTY  
**CURRENT USE:** UNMANNED CELLULAR FACILITY  
**NEW USE:** UNMANNED CELLULAR FACILITY

**AMSL / AGL:** 5076' / 111'      **PARCEL NUMBER (S):** 21-008-0029 & 21-008-0036

**LEASE AREA:** (E) 370 SQ FT.

**PROJECT SUMMARY**

**DO NOT SCALE DRAWINGS**

CONTRACTOR SHALL VERIFY ALL PLANS & EXISTING LOCATIONS. CONDITIONS ON THE JOB SITE & SHALL IMMEDIATELY NOTIFY THE ENGINEER IN WRITING OF ANY DISCREPANCIES BEFORE PROCEEDING WITH THE WORK OR BE RESPONSIBLE FOR SAME

SHEET	DESCRIPTION
T-1	TITLE SHEET
T-2	GENERAL NOTES
T-3	GENERAL NOTES
T-4	GENERAL NOTES
A-1	OVERALL SITE PLAN
A-2	ENLARGED SITE PLAN
A-3	EQUIPMENT PLANS
A-4	ANTENNA PLANS
A-5	WEST ELEVATION
A-6	NORTH ELEVATION
A-7	DETAILS
A-8	DETAILS
E-1	ONE-LINE DIAGRAM & POWER PANEL SCHEDULE
G-1	GROUNDING PLANS
G-2	GROUNDING DETAILS

SPRINT PROPOSES TO MODIFY AN EXISTING UNMANNED TELECOMMUNICATIONS FACILITY

- REMOVE (6) EXISTING PANEL ANTENNAS (2 PER SECTOR)
- INSTALL (3) NEW PANEL ANTENNAS (1 PER SECTOR)
- REMOVE (3) EQUIPMENT CABINET
- INSTALL (1) NEW MMBS CABINET
- INSTALL (1) NEW SBU CABINET
- REMOVE ALL EXISTING SPRINT ANTENNA COAXIAL CABLES
- INSTALL (3) NEW HYBRIFLEX FIBER OPTIC CABLES USING EXISTING COAX ROUTE (1 PER SECTOR)
- INSTALL (9) NEW RRU'S

**PROJECT DESCRIPTION**



**ARCHITECT:**  
 TECHNOLOGIES ASSOCIATES  
 9847 SOUTH 500 WEST  
 SANDY, UT 84070  
 CONTACT: JEFF VANDERVEEN  
 PHONE #: (801) 910-2965  
 EMAIL: jeff.vanderveen@taec.net

**RF ENGINEER:**  
 STA NETWORK SERVICES  
 CONTACT: DENIS A. SEQUEIRA  
 PHONE #: (972) 375-2494  
 EMAIL: d.sequeira@sta.samsung.com

**STRUCTURAL ENGINEER:**  
 TECHNOLOGIES ASSOCIATES  
 9847 SOUTH 500 WEST  
 SANDY, UT 84070  
 CONTACT: JEFF VANDERVEEN  
 PHONE #: (801) 910-2965  
 EMAIL: jeff.vanderveen@taec.net

**ELECTRICAL COMPANY:**  
 ROCKY MOUNTAIN POWER  
 201 SOUTH MAIN ST. STE. 2300  
 SALT LAKE CITY, UT 84111  
 CONTACT: CUSTOMER SERVICE  
 PHONE #: 1-800-469-3981

**SITE ACQ. PROJECT MANAGER:**  
 GENERAL DYNAMICS WIRELESS SERVICES  
 CONTACT: MATTHEW T. SCHUTJER  
 PHONE #: (206) 518-4605  
 EMAIL: matt.schutjer@gdit.com

**TELCO COMPANY:**  
 QWEST  
 CONTACT: CUSTOMER SERVICE  
 PHONE #: 1-800-475-7526

**CONSTRUCTION MANAGER:**  
 GENERAL DYNAMICS WIRELESS SERVICES  
 1171 WEST 2400 SOUTH  
 WEST VALLEY CITY, UT 84119  
 CONTACT: RICK STAHL  
 PHONE #: (425) 213-3028  
 EMAIL: richard.stahl@gdit.com

**STARTING FROM SPRINT OFFICE: 4393 RIVERBOAT RD., TAYLORSVILLE, UT 84123:**

- HEAD SOUTH ON RIVERBOAT RD TOWARD W 4500 S
- TAKE THE 1ST LEFT ONTO W 4500 S
- TURN LEFT TO MERGE ONTO I-15 N
- SLIGHT RIGHT ONTO U.S. 89 N (SIGNS FOR I-84 E/SO. OGDEN)
- MERGE ONTO I-84 E VIA THE RAMP TO MORGANEVANSTON
- TAKE EXIT 82 FOR UT-167 TOWARD MOUNTAIN GREENHUNTSVILLE
- TURN LEFT ONTO UT-167 NIN 6300 W CONTINUE TO FOLLOW UT-167 N
- TURN LEFT ONTO UT-167 NTRAPPERS LOOP RD
- TURN LEFT ONTO UT-167 NTRAPPERS LOOP RD CONTINUE TO FOLLOW UT-167 N
- TURN RIGHT ONTO UT-39 EUT-39 SCENIC E/E 600 S/OGDEN CANYON CONTINUE TO FOLLOW UT-39 EUT-39 SCENIC E
- CONTINUE ONTO N 7800 E/STATE ROUTE 166 CONTINUE TO FOLLOW STATE ROUTE 166
- TURN RIGHT ONTO E 1075 N

**DRIVING DIRECTIONS**

APPROVAL	SIGNATURE	DATE
SITE ACQUISITION MANAGER		
CONSTRUCTION MANAGER		
A&E MANAGER		
PLANNING CONSULTANT		
RF MANAGER		
RF ENGINEER		
PROPERTY OWNER		
SPRINT REPRESENTATIVE		
AAV MANAGER		

**SIGNATURE BLOCK**

REV	DATE	DESCRIPTION	BY
C	02/07/2013	ISSUED FOR 90% REVIEW	AC
B	01/21/2013	ISSUED FOR 90% REVIEW	JAA
A	12/03/2012	ISSUED FOR 90% REVIEW	JAA

IT IS A VIOLATION OF LAW FOR ANY PERSON, UNLESS THEY ARE ACTING UNDER THE DIRECTION OF A LICENSED PROFESSIONAL ENGINEER, TO ALTER THIS DOCUMENT.

NETWORK VISION MMBS LAUNCH  
**HUNTSVILLE**  
**SL54XC068**  
 750 N. 7200 E.  
 HUNTSVILLE, UT 84137

SHEET TITLE  
**TITLE SHEET**

SHEET NUMBER  
**T-1**

**DIG ALERT** 811 Know what's below. CALL before you dig.

CALL AT LEAST TWO WORKING DAYS BEFORE YOU DIG

NOTE: THE ORIGINAL SIZE OF THIS PLAN IS 24" X 36". SCALE RATIO IS NOT VALID FOR REDUCED OR ENLARGED SHEET SIZES

**GENERAL CONSTRUCTION NOTES**

- FOR THE PURPOSE OF CONSTRUCTION DRAWINGS, THE FOLLOWING DEFINITIONS SHALL APPLY:  
OWNER - SPRINT  
SUBCONTRACTOR - CONTRACTOR (CONSTRUCTION)
- ALL SITE WORK SHALL BE COMPLETED AS INDICATED ON THE DRAWINGS AND SPRINT PROJECT SPECIFICATIONS.
- GENERAL CONTRACTOR AND SUBCONTRACTOR SHALL VISIT THE SITE AND SHALL FAMILIARIZE HIMSELF WITH ALL CONDITIONS AFFECTING THE PROPOSED WORK AND SHALL MAKE PROVISIONS GENERAL CONTRACTOR AND SUBCONTRACTOR SHALL BE RESPONSIBLE FOR FAMILIARIZING HIMSELF WITH ALL CONTRACT DOCUMENTS, FIELD CONDITIONS, DIMENSIONS, AND CONFIRMING THAT THE WORK MAY BE ACCOMPLISHED AS SHOWN PRIOR TO PROCEEDING WITH CONSTRUCTION, ANY DISCREPANCIES SHALL BE BROUGHT TO THE ATTENTION OF THE ARCHITECT / ENGINEER PRIOR TO THE COMMENCEMENT OF WORK.
- ALL MATERIALS FURNISHED AND INSTALLED SHALL BE IN STRICT ACCORDANCE WITH ALL APPLICABLE CODES, REGULATIONS, AND ORDINANCES, GENERAL CONTRACTOR SHALL ISSUE ALL APPROPRIATE NOTICES AND COMPLY WITH ALL LAWS, ORDINANCES, RULES REGULATIONS, AND LAWFUL ORDERS OF ANY PUBLIC AUTHORITY REGARDING THE PERFORMANCE OF WORK.
- ALL WORK CARRIED OUT SHALL COMPLY WITH ALL APPLICABLE MUNICIPAL AND UTILITY COMPANY SPECIFICATIONS AND LOCAL JURISDICTIONAL CODES, ORDINANCES, AND APPLICABLE REGULATIONS.
- UNLESS OTHERWISE, THE WORK SHALL INCLUDE FURNISHING, MATERIALS, EQUIPMENT, APPURTENANCES, AND LABOR NECESSARY TO COMPLETE ALL INSTALLATIONS AS INDICATED ON THE DRAWINGS.
- PLANS ARE NOT TO BE SCALED, THESE PLANS ARE INTENDED TO BE A DIAGRAMMATIC OUTLINE ONLY UNLESS OTHERWISE NOTED. DIMENSIONS SHOWN ARE TO BE FINISH SURFACES UNLESS OTHERWISE NOTED. SPACING BETWEEN EQUIPMENT IS THE MINIMUM REQUIRED CLEARANCE. THEREFORE, IT IS CRITICAL TO FIELD VERIFY DIMENSIONS, SHOULD THERE BE ANY QUESTIONS REGARDING THE CONTRACT DOCUMENTS, THE SUBCONTRACTOR SHALL BE RESPONSIBLE FOR OBTAINING A CLARIFICATION FROM THE ARCHITECT / ENGINEER PRIOR TO PROCEEDING WITH THE WORK. DETAILS ARE INTENDED TO SHOWN DESIGN INTENT. MODIFICATIONS MAY BE REQUIRED TO SUIT JOB DIMENSIONS OR CONDITIONS AND SUCH MODIFICATIONS SHALL BE INCLUDED AS PART OF WORK AND PREPARED BY THE ARCHITECT / ENGINEER PRIOR TO PROCEEDING WITH WORK.
- THE SUBCONTRACTOR SHALL INSTALL ALL EQUIPMENT AND MATERIALS IN ACCORDANCE WITH MANUFACTURER'S RECOMMENDATIONS UNLESS SPECIFICALLY STATED OTHERWISE.
- IF THE SPECIFIED EQUIPMENT CANNOT BE INSTALLED AS SHOWN ON THESE DRAWINGS, THE SUBCONTRACTOR SHALL PROPOSE AN ALTERNATIVE SPACE FOR APPROVAL BY THE ARCHITECT / ENGINEER PRIOR TO PROCEEDING.
- GENERAL CONTRACTOR SHALL BE RESPONSIBLE FOR THE SAFETY OF WORK AREA, ADJACENT AREAS AND BUILDING OCCUPANTS THAT ARE LIKELY TO BE AFFECTED BY THE WORK UNDER THIS CONTRACT. WORK SHALL CONFORM TO ALL OSHA REQUIREMENTS AND THE LOCAL JURISDICTION.
- GENERAL CONTRACTOR SHALL COORDINATE WORK AND SCHEDULE WORK ACTIVITIES WITH OTHER DISCIPLES.
- ERECTION SHALL BE DONE IN A WORKMANLIKE MANNER BY COMPETENT EXPERIENCED WORKMAN IN ACCORDANCE WITH APPLICABLE CODES AND THE BEST ACCEPTED PRACTICE. ALL MEMBERS SHALL BE LAID PLUMB AND TRUE AS INDICATED ON THE DRAWINGS.
- SEAL PENETRATIONS THROUGH FIRE RATED AREAS WITH UL LISTED MATERIALS APPROVED BY LOCAL JURISDICTION. SUBCONTRACTOR SHALL KEEP AREA CLEAN, HAZARD FREE, AND DISPOSE OF ALL DEBRIS.
- WORK PREVIOUSLY COMPLETED IS REPRESENTED BY LIGHT SHADED LINES AND NOTES. THE SCOPE OF WORK FOR THIS PROJECT IS REPRESENTED BY DARK SHADED LINES AND NOTES. SUBCONTRACTOR SHALL NOTIFY THE GENERAL CONTRACTOR OF ANY EXISTING CONDITIONS THAT DEViate FROM THE DRAWING PRIOR TO THE BEGINNING CONSTRUCTION.
- SUBCONTRACTOR SHALL PROVIDE WRITTEN NOTICE TO THE CONSTRUCTION MANAGER 48 HOURS PRIOR TO COMMENCEMENT OF WORK.
- THE SUBCONTRACTOR SHALL PROTECT EXISTING IMPROVEMENTS, PAVEMENTS, CURBS, LANDSCAPING AND STRUCTURES. ANY DAMAGED PART SHALL BY REPAIRED AT THE SUBCONTRACTOR'S EXPENSE TO THE SATISFACTION OF THE OWNER.
- THE SUBCONTRACTOR SHALL CONTACT UTILITY LOCATING SERVICES PRIOR TO THE START OF CONSTRUCTION.
- GENERAL CONTRACTOR SHALL COORDINATE AND MAINTAIN ACCESS FOR ALL TRADES AND SUBCONTRACTORS TO THE SITE AND / OR BUILDING.
- THE GENERAL CONTRACTOR SHALL BE RESPONSIBLE FOR SECURITY OF THE SITE FOR THE DURATION OF CONSTRUCTION UNTIL JOB COMPLETION.
- THE GENERAL CONTRACTOR SHALL MAINTAIN, IN GOOD CONDITION, ONE COMPLETE SET OF PLANS WITH ALL REVISIONS, ADDENDA, AND CHANGE ORDERS ON THE PREMISES AT ALL TIMES.
- THE GENERAL CONTRACTOR AND SUBCONTRACTOR SHALL PROVIDE PORTABLE FIRE EXTINGUISHERS WITH A RATING OF NOT LESS THAN 2-A TO 2-A-10B-C AND SHALL BE WITHIN 75 FEET OF TRAVEL DISTANCE TO ALL PORTIONS OF WHERE THE WORK IS BEING COMPLETED DURING CONSTRUCTION.
- ALL EXISTING ACTIVE SEWER, WATER, GAS, ELECTRIC, AND OTHER UTILITIES SHALL BE PROTECTED AT ALL TIMES, AND WHERE REQUIRED FOR THE PROPER EXECUTION OF THE WORK, SHALL BE RELOCATED AS DIRECTED BY THE ARCHITECT / ENGINEER. EXTREME CAUTION SHOULD BE USED BY THE SUBCONTRACTOR WHEN EXCAVATING OR DRILLING PIERS AROUND OR NEAR UTILITIES. SUBCONTRACTOR SHALL PROVIDE SAFETY TRAINING FOR THE WORKING CREW. THIS SHALL INCLUDE, BUT NOT BE LIMITED, TO: A) FALL PROTECTION, B) CONFINED SPACE, C) ELECTRICAL SAFETY, D) TRENCHING & EXCAVATION.
- ALL EXISTING INACTIVE SEWER, WATER, GAS, ELECTRIC, AND OTHER UTILITIES, WHICH INTERFERE WITH THE EXECUTION OF THE WORK, SHALL BE REMOVED, CAPPED, PLUGGED OR OTHERWISE DISCONNECTED AT POINTS WHICH WILL NOT INTERFERE WITH THE EXECUTION OF THE WORK, AS DIRECTED BY THE RESPONSIBLE ARCHITECT / ENGINEER, AND SUBJECT TO THE APPROVAL OF THE OWNER AND / OR LOCAL UTILITIES.
- THE AREAS OF THE OWNER'S PROPERTY DISTURBED BY THE WORK AND NOT COVERED BY THE TOWER, EQUIPMENT OF DRIVEWAY, SHALL BY GRADED TO A UNIFORM SLOPE, AND STABILIZED TO PREVENT EROSION.
- SUBCONTRACTOR SHALL MINIMIZE DISTURBANCE TO THE EXISTING SITE DURING CONSTRUCTION, EROSION CONTROL MEASURES, IF REQUIRED DURING CONSTRUCTION, SHALL BE IN CONFORMANCE WITH THE FEDERAL AND LOCAL JURISDICTION FOR EROSION AND SEDIMENT CONTROL.
- NO FILL OR EMBANKMENT MATERIAL SHALL BY PLACED ON FROZEN GROUND. FROZEN MATERIALS, SNOW OR ICE SHALL NOT BE PLAGE IN ANY FILL OR EMBANKMENT.
- THE SUBGRADE SHALL BE BROUGHT TO A SMOOTH GRADE AND COMPACTED TO 95 PERCENT STANDARD PROCTOR DENSITY UNDER PAVEMENT AND STRUCTURES AND 80 PERCENT STANDARD PROCTOR DENSITY IN OPEN SPACE. ALL TRENCHES IN PUBLIC RIGHT OF WAY SHALL BY BACKFILLED WITH FLOWABLE FILL OR OTHER MATERIAL. PRE-APPROVED BY THE LOCAL JURISDICTION.
- ALL NECESSARY RUBBISH, STUMPS, DEBRIS, STICKS, STONES AND OTHER REFUSE SHALL BE REMOVED FROM THE SITE AND DISPOSED OF IN A LAWFUL MANNER.
- ALL BROCHURES, OPERATING AND MAINTENANCE MANUALS, CATALOGS, SHOP DRAWINGS, AND OTHER DOCUMENTS SHALL BE TURNED OVER TO THE GENERAL CONTRACTOR AT COMPLETION OF CONSTRUCTION AND PRIOR TO PAYMENT.
- SUBCONTRACTOR SHALL SUBMIT A COMPLETE SET OF AS-BUILT REDLINES TO THE GENERAL CONTRACTOR UPON COMPLETION OF PROJECT AND PRIOR TO FINAL PAYMENT.
- SUBCONTRACTOR SHALL LEAVE PREMISES IN A CLEAN CONDITION.
- THE PROPOSED FACILITY WILL BE UNMANNED AND DOES NOT REQUIRE POTABLE WATER OR SEWER SERVICE, AND IS NOT FOR HUMAN HABITAT (NO HANDICAP ACCESS REQUIRED).
- OCCUPANCY IS LIMITED TO PERIODIC MAINTENANCE AND INSPECTION, APPROXIMATELY 2 TIMES PER MONTH, BY SPRINT TECHNICIANS.
- NO OUTDOOR STORAGE OR SOLID WASTE CONTAINERS ARE PROPOSED.
- ALL MATERIAL SHALL BE FURNISHED AND WORK SHALL BE PERFORMED IN ACCORDANCE WITH THE LATEST REVISION SPRINT MOBILITY GROUNDING STANDARD 'TECHNICAL SPECIFICATION FOR CONSTRUCTION OF WIRELESS SITES' AND 'TECHNICAL SPECIFICATION FOR FACILITY GROUNDING.' IN CASE OF A CONFLICT BETWEEN THE CONSTRUCTION SPECIFICATION AND THE DRAWINGS, THE DRAWINGS SHALL GOVERN.
- SUBCONTRACTORS SHALL BE RESPONSIBLE FOR OBTAINING ALL PERMITS AND INSPECTIONS REQUIRED FOR CONSTRUCTION. IF SUBCONTRACTOR CANNOT OBTAIN A PERMIT, THEY MUST NOTIFY THE GENERAL CONTRACTOR IMMEDIATELY.
- SUBCONTRACTOR SHALL REMOVE ALL TRASH AND DEBRIS FROM THE SITE ON A DAILY BASIS.
- INFORMATION SHOWN ON THESE DRAWINGS WAS OBTAINED FROM SITE VISITS AND/OR DRAWINGS PROVIDED BY THE SITE OWNER. CONTRACTORS SHALL NOTIFY THE ENGINEER OF ANY DISCREPANCIES PRIOR TO ORDERING MATERIAL OF PROCEEDING WITH CONSTRUCTION.
- NO WHITE STROBIC LIGHTS ARE PERMITTED. LIGHTING, IF REQUIRED, WILL MEET FAA STANDARDS AND REQUIREMENTS.
- ALL COAXIAL CABLE INSTALLATIONS TO FOLLOW MANUFACTURER'S INSTRUCTIONS AND RECOMMENDATIONS.
- NO NOISE, SMOKE, DUST, OR VIBRATION WILL RESULT FROM THIS FACILITY. (DISREGARD THIS NOTE IF THIS SITE HAS A GENERATOR)
- NO ADDITIONAL PARKING TO BE PROPOSED. EXISTING ACCESS AND PARKING TO REMAIN, UNLESS NOTED OTHERWISE.
- NO LANDSCAPING IS PROPOSED AT THIS SITE, UNLESS NOTED OTHERWISE.

**SITE WORK & DRAINAGE**

**PART 1 - GENERAL**

CLEARING, GRUBBING, STRIPPING, EROSION CONTROL, SURVEY, LAYOUT, SUBGRADE PREPARATION AND FINISH GRADING AS REQUIRED TO COMPLETE THE PROPOSED WORK SHOWN IN THESE PLANS.

**1.1 REFERENCES:**

- DOT (STATE DEPARTMENT OF TRANSPORTATION STANDARD SPECIFICATIONS FOR HIGHWAY CONSTRUCTION - CURRENT EDITION).
- ASTM (AMERICAN SOCIETY FOR TESTING AND MATERIALS).
- OSHA (OCCUPATION SAFETY AND HEALTH ADMINISTRATION).

**1.2 INSPECTION AND TESTING:**

- FIELD TESTING OF EARTHWORK COMPACTION AND CONCRETE CYLINDERS SHALL BE PERFORMED BY SUBCONTRACTORS INDEPENDENT TESTING LAB, THIS WORK IS TO BE COORDINATED BY THE SUBCONTRACTOR.
  - ALL WORK SHALL BY INSPECTED AND RELEASED BY THE GENERAL CONTRACTOR WHO SHALL CARRY OUT THE GENERAL INSPECTION OF THE WORK WITH SPECIFIC CONCERN TO PROPER PERFORMANCE OF THE WORK AS SPECIFIED AND / OR CALLED FOR ON THE DRAWINGS. IT IS THE SUBCONTRACTOR'S RESPONSIBILITY TO REQUEST TIMELY INSPECTIONS PRIOR TO PROCEEDING WITH FURTHER WORK THAT WOULD MAKE PARTS OF WORK INACCESSIBLE OR DIFFICULT TO INSPECT.
- 1.3 SITE MAINTENANCE AND PROTECTION:**
- PROVIDE ALL NECESSARY JOB SITE MAINTENANCE FROM COMMENCEMENT OF WORK UNTIL COMPLETION OF THE SUBCONTRACT.
  - AVOID DAMAGE TO THE SITE AND TO EXISTING FACILITIES, STRUCTURES, TREES, AND SHRUBS DESIGNATED TO REMAIN. TAKE PROTECTIVE MEASURES TO PREVENT EXISTING FACILITIES THAT ARE NOT DESIGNATED FOR REMOVAL FROM BEING DAMAGED BY THE WORK.
  - KEEP SITE FREE OF ALL PONDING WATER.
  - PROVIDE EROSION CONTROL MEASURES IN ACCORDANCE WITH STATE DOT AND EPA REQUIREMENTS.
  - PROVIDE AND MAINTAIN ALL TEMPORARY FENCING, BARRICADES, WARNING SIGNALS, AND SIMILAR DEVICES NECESSARY TO PROTECT AGAINST THEFT FROM PROPERTY DURING THE ENTIRE PERIOD OF CONSTRUCTION. REMOVE ALL SUCH DEVICES UPON COMPLETION OF THE WORK.
  - EXISTING UTILITIES: DO NOT INTERRUPT EXISTING SERVING FACILITIES OCCUPIED BY THE OWNER OR OTHERS, EXCEPT WHEN PERMITTED IN WRITING BY THE ENGINEER AND THEN ONLY AFTER ACCEPTABLE TEMPORARY UTILITY SERVICES HAVE BEEN PROVIDED.
  - PROVIDE A MINIMUM 48-HOUR NOTICE TO THE ENGINEER AND RECEIVE WRITTEN NOTICE TO PROCEED BEFORE INTERRUPTING ANY UTILITY SERVICE.

**PART 2 - PRODUCTS**

- SUITABLE BACKFILL: ASTM D2321 (CLASS I, II, III OR IVA) FREE FROM FROZEN LUMPS, REFUSE, STONES, OR ROCKS LARGER THAN 3 INCHES IN ANY DIMENSION OR OTHER MATERIAL THAT MAY MAKE THE INORGANIC MATERIAL UNSUITABLE FOR BACKFILL.
- NON-POROUS GRANULAR EMBANKMENT AND BACKFILL: ASTM D2321 (CLASS III, IVA OR IVB) COARSE AGGREGATE, FREE FROM FROZEN LUMPS, REFUSE, STONES OR ROCKS LARGER THAN 3 INCHES IN ANY DIMENSION OR OTHER MATERIAL THAT MAY MAKE THE INORGANIC MATERIAL UNSUITABLE FOR BACKFILL.
- POROUS GRANULAR EMBANKMENT AND BACKFILL: ASTM 52321 (CLASS IA, IB OR II) COARSE AGGREGATE FREE FROM FROZEN LUMPS, REFUSE STONES OR ROCKS LARGER THAN 3 INCHES IN ANY DIMENSION OR OTHER MATERIAL THAT MAY MAKE THE INORGANIC MATERIAL UNSUITABLE FOR BACKFILL.
- SELECT STRUCTURAL FILL: GRANULAR FILL MATERIAL MEETING THE REQUIREMENTS OF ASTM E850-95, FOR USE AROUND UNDER STRUCTURES WHERE STRUCTURAL FILL MATERIAL ARE REQUIRED.
- GRANULAR BEDDING AND TRENCH BACKFILL: WELL - GRADED SAND MEETING THE GRADATION REQUIREMENTS OF ASTM D2487 (SE OR SW-SM).
- COARSE AGGREGATE FOR ACCESS ROAD SUB-BASE COURSE SHALL CONFORM ASTM D2940.
- UNSUITABLE MATERIAL: HIGH AND MODERATELY PLASTIC SILTS AND CLAYS (LL-45), MATERIAL CONTAINING REFUSE, FROZEN LUMPS, DEMOLISHED BITUMINOUS MATERIAL, VEGETATIVE MATTER, WOOD, STONES IN EXCESS OF 3 INCHES IN ANY DIMENSIONS AND DEBRIS AS DETERMINED BY THE CONSTRUCTION MANAGER. TYPICALLY WILL BE SOILS CLASSIFIED BY ASTM AS PT, MH, CH, OH, ML, AND OL.
- GEOTEXTILE FABRIC: MIRAFI 500X OR APPROVED EQUAL.
- PLASTIC MARKING TAPE: SHALL BE ACID AND ALKALI RESISTANT POLYETHYLENE FILM SPECIFICALLY MANUFACTURED FOR MARKING THE LOCATIONS OF UTILITIES 6 INCHES WIDE WITH A MINIMUM THICKNESS OF 0.004 INCHES. TAPE SHALL HAVE MINIMUM STRENGTH OF 1500 PSI IN BOTH DIRECTIONS AND MANUFACTURED WITH INTEGRAL CONDUCTORS, FOIL BACKING OR OTHER MEANS TO ENABLE DETECTION BY A METAL DETECTOR WHEN BURIED UP TO 3 FEET DEEP. THE METALLIC CORE OF THE TAPE SHALL BE ENCASED IN A PROTECTIVE JACKET OR PROVIDED WITH OTHER MEANS TO PROTECT IT FROM CORROSION. TAPE COLOR SHALL BE RED FOR ELECTRIC UTILITIES AND ORANGE FOR TELECOMMUNICATION UTILITIES.

**PART 3 - EXECUTION**

**3.1 GENERAL:**

- BEFORE START GENERAL SITE PREPARATION ACTIVITIES, INSTALL EROSION AND SEDIMENT CONTROL MEASURES. THE WORK AREA SHALL BE CONSTRUCTED AND MAINTAINED IN SUCH CONDITION THAT IN THE EVENT OF RAIN THE SITE WILL BE DRAINED AT ANY TIME.
- BEFORE ALL SURVEY, LAYOUT, STAKING, AND MARKING, ESTABLISH AND MAINTAIN ALL LINE, GRADES, ELEVATIONS AND BENCHMARKS NEEDED FOR EXECUTION OF THE WORK.
- CLEAR AND GRUB THE AREA WITHIN THE LIMITS OF THE SITE. REMOVE TREES, BRUSH, STUMPS, RUBBISH, OTHER DEBRIS, AND VEGETATION RESTING ON OR PROTRUDING THROUGH THE SURFACE OF THE SITE AREA TO BE CLEARED.
  - REMOVE THE FOLLOWING MATERIALS TO A DEPTH OF NO LESS THAN 12 INCHES BELOW THE ORIGINAL GROUND SURFACE: ROOTS, STUMPS, AND OTHER DEBRIS, BRUSH AND REFUSE EMBEDDED IN OR PROTRUDING THROUGH THE GROUND SURFACE, RAKE, DISK, OR PLOW THE AREA TO A DEPTH OF NO LESS THAN 6 INCHES, AND REMOVE TO A DEPTH OF 12 INCHES ALL ROOTS AND OTHER DEBRIS THEREBY EXPOSED.
  - REMOVE TOPSOIL MATERIAL COMPLETELY FROM THE SURFACE UNTIL THE SOIL NO LONGER MEETS THE DEFINITION OF TOPSOIL. AVOID MIXING TOPSOIL WITH SUBSOIL OR OTHER UNDESIRABLE MATERIALS.
  - EXCEPT WHERE EXCAVATION TO GREATER DEPTH IS INDICATED TILL DEPRESSIONS RESULTING FROM CLEARING, GRUBBING, AND DEMOLITION WORK COMPLETELY WITH SUITABLE FILL.
- REMOVE FROM THE SITE AND DISPOSE IN AN AUTHORIZED LANDFILL ALL DEBRIS RESULTING FROM CLEARING AND GRUBBING OPERATIONS. BURNING WILL NOT BE PERMITTED.
- PRIOR TO EXCAVATING, THOROUGHLY EXAMINE THE AREA TO BE EXCAVATED AND / OR TRENCHED TO VERIFY THE LOCATIONS OF FEATURES ON THE DRAWINGS AND TO ASCERTAIN THE EXISTENCE AND LOCATION OF ANY STRUCTURE, UNDERGROUND STRUCTURE, OR OTHER ITEM THAT MIGHT INTERFERE WITH THE PROPOSED CONSTRUCTION. NOTIFY THE CONSTRUCTION MANAGER OF ANY OBSTRUCTIONS THAT WILL PREVENT ACCOMPLISHMENT OF THE WORK AS INDICATED ON THE DRAWINGS.
- SEPARATE AND STOCK PILE ALL EXCAVATED MATERIALS SUITABLE FOR BACKFILL. ALL EXCESS EXCAVATED AND UNSUITABLE MATERIALS SHALL BE DISPOSED OF OFF-SITE IN A LEGAL MANNER.

**3.2 BACKFILL:**

- AS SOON AS PRACTICAL, AFTER COMPLETING CONSTRUCTION OF THE RELATED STRUCTURE, INCLUDING EXPIRATION OF THE SPECIFIED MINIMUM CURING PERIOD FOR CAST-IN-PLACE CONCRETE, BACKFILL THE EXCAVATION WITH APPROVED MATERIAL TO RESTORE THE REQUIRED FINISHED GRADE.
  - PRIOR TO PLACING BACKFILL AROUND STRUCTURES, ALL FORMS SHALL BE REMOVED AND THE EXCAVATION CLEANED OF ALL TRASH, DEBRIS AND UNSUITABLE MATERIALS.
  - BACKFILL BY PLACING AND COMPACTING SUITABLE BACKFILL MATERIAL OR SELECT GRANULAR BACKFILL MATERIAL WHEN REQUIRED IN UNIFORM HORIZONTAL LAYERS OF NO GREATER THAN 8-INCHES LOOSE THICKNESS AND COMPACTED, WHERE HAND OPERATED COMPACTORS ARE USED, THE FILL MATERIAL SHALL BE PLACED IN LIFTS NOT TO EXCEED 4 INCHES IN LOOSE DEPTH AND COMPACTED.
  - WHENEVER THE DENSITY TESTING INDICATES THAT THE CONTRACTOR HAS NOT OBTAINED THE SPECIFIED DENSITY, THE SUCCEEDING LAYER SHALL NOT BE PLACED UNTIL THE SPECIFICATION REQUIREMENTS ARE MET UNLESS OTHERWISE AUTHORIZED BY THE GEOTECHNICAL ENGINEER. THE CONTRACTOR SHALL TAKE WHATEVER APPROPRIATE ACTION IS NECESSARY, SUCH AS DISKING AND DRYING, ADDING WATER, OR INCREASING THE COMPACTIVE EFFORT TO MEET THE MINIMUM COMPACTION REQUIREMENTS.
- THOROUGHLY COMPACT EACH LAYER OF BACKFILL TO A MINIMUM OF 95% OF THE MAXIMUM DRY DENSITY AS PROVIDED BY THE STANDARD PROCTOR TEST, ASTM D 698.

**3.3 TRENCH EXCAVATION:**

- UTILITY TRENCHES SHALL BE EXCAVATED TO THE LINES AND GRADES SHOWN ON THE DRAWINGS OR AS DIRECTED BY THE GENERAL CONTRACTOR. PROVIDE SHORING, SHEETING AND BRACING AS REQUIRED TO PREVENT CAVING OR SLOUGHING OF THE TRENCH WALLS.
- EXTEND THE TRENCH WIDTH A MINIMUM OF 7 INCHES BEYOND THE OUTSIDE EDGE OF THE OUTERMOST CONDUIT.
- WHEN SORE YIELDING, OR OTHERWISE UNSTABLE SOIL CONDITIONS ARE ENCOUNTERED, BACKFILL AT THE REQUIRED TRENCH TO A DEPTH OF NO LESS THAN 12 INCHES BELOW THE REQUIRED ELEVATION AND BACKFILL WITH GRANULAR BEDDING MATERIAL.

**3.4 TRENCH BACKFILL:**

- PROVIDE GRANULAR BEDDING MATERIAL IN ACCORDANCE WITH THE DRAWING AND THE UTILITY REQUIREMENTS.
- NOTIFY THE GENERAL CONTRACTOR 24 HOURS IN ADVANCE OF BACKFILLING.
- CONDUCT UTILITY CHECK TESTS BEFORE BACKFILLING. BACKFILL AND COMPACT TRENCH BEFORE ACCEPTANCE TESTING.
- PLACE GRANULAR TRENCH BACKFILL UNIFORMLY ON BOTH SIDES OF THE CONDUITS IN 6-INCHES UNCOMPACTED LIFTS UNTIL 12 INCHES OVER THE CONDUITS. SOLIDLY RAM AND TAMP BACKFILL INTO SPACE AROUND CONDUITS.
- PROTECT CONDUIT FROM LATERAL MOVEMENT, IMPACT DAMAGE OR UNBALANCED LOADING.
- ABOVE THE CONDUIT EMBEDMENT ZONE, PLACE AND COMPACT SATISFACTORY BACKFILL MATERIAL IN 8-INCH MAXIMUM LOOSE THICKNESS LIFTS TO RESTORE THE REQUIRED FINISHED SURFACE GRADE.
- COMPACT FINAL TRENCH BACKFILL TO A DENSITY EQUAL TO OR GRATER THAT THAT OF THE EXISTING UNDISTURBED MATERIAL IMMEDIATELY ADJACENT TO THE TRENCH BUT NO LESS THAT A MINIMUM OF 95% OF THE MAXIMUM DRY DENSITY AS PROVIDED BY THE STANDARD PROCTOR TEST, ASTM D 698.

**3.5 AGGREGATE ACCESS ROAD:**

- CLEAR, GRUB, STRIP AND EXCAVATE FOR THE ACCESS ROAD TO THE LINES AND GRADES INDICATED ON THE DRAWINGS, SCARIFY TO A DEPTH OF 6 INCHES AND PROOF-ROLL. ALL HOLES, RUTS, SOFT PLACES AND OTHER DEFECTS SHALL BE CORRECTED.
- THE ENTIRE SUBGRADE SHALL BE COMPACTED TO NOT LESS THAN 95 PERCENT OF THE MAXIMUM DRY DENSITY AS PROVIDED BY THE STANDARD PROCTOR TEST, ASTM D 1557.
- AFTER PREPARATION OF THE SUBGRADE IS COMPLETE THE GEOTEXTILE FABRIC (MIRAFI 500X) SHALL BE INSTALLED TO THE LIMITS INDICATED ON THE DRAWINGS BY ROLLING THE FABRIC OUT LONGITUDINALLY ALONG THE ROADWAY THE FABRIC SHALL NOT BE DRAGGED ACROSS THE SUBGRADE. PLACE THE ENTIRE ROLL IN A SINGLE OPERATION, ROLLING OUT AS SMOOTHLY AS POSSIBLE.
  - OVERLAPS PARALLEL TO THE ROADWAY WILL BE PERMITTED AT THE CENTERLINE AND AT LOCATIONS BEYOND THE ROADWAY SURFACE WIDTH (I.E. WITHIN THE SHOULDER WIDTH) ONLY. NO LONGITUDINAL OVERLAPS SHALL BE LOCATED BETWEEN THE CENTERLINE AND THE SHOULDER. PARALLEL OVERLAPS SHALL BE A MINIMUM OF 3 FEET WIDE.
  - TRANSVERSE (PERPENDICULAR TO THE ROADWAY) OVERLAPS AT THE END OF A ROLL. SHALL OVERLAP IN THE DIRECTION OF THE AGGREGATE PLACEMENT (PREVIOUS ROLL ON TOP) AND SHALL HAVE A MINIMUM LENGTH OF 3 FEET.
  - ALL OVERLAPS SHALL BE PINNED WITH STAPLES OF NAILS A MINIMUM OF 10 INCHES LONG TO INSURE POSITIONING DURING PLACEMENT OF AGGREGATE. PIN LONGITUDINAL SEAMS AT 25 FOOT CENTERS AND TRANSVERSE SEAMS EVERY 5 FEET.
- THE AGGREGATE BASE AND SURFACE COURSES SHALL BE CONSTRUCTED IN LAYERS NOT MORE THAN 4 INCH (COMPACTED) THICKNESS. AGGREGATE TO BE PLACED ON GEOTEXTILE FABRIC SHALL BE END - DUMPED ON THE FABRIC FROM THE FREE END OF THE FABRIC OR OVER PREVIOUSLY PLACED AGGREGATE. THE FIRST LIFT SHALL BE BLADED DOWN TO A THICKNESS OF 8 INCHES PRIOR TO COMPACTION. AT NO TIME SHALL EQUIPMENT, EITHER TRANSPORTING THE AGGREGATE OR GRADING THE AGGREGATE, BE PERMITTED ON THE ROADWAY WITH LESS THAN 4 INCHES OF MATERIAL COVERING THE FABRIC.
- THE AGGREGATE SHALL BE IMMEDIATELY COMPACTED TO NOT LESS THAN 95 PERCENT OF THE MAXIMUM DRY DENSITY AS PROVIDED BY THE PROCTOR TEST, ASTM D 1557 WITH A TAMPING ROLLER, OR WITH A PNEUMATIC - TIRE ROLLER, OR WITH A VIBRATORY MACHINE OR ANY COMBINATION OF THE ABOVE. THE TOP LAYER SHALL BE GIVEN A FINAL ROLLING WITH A THREE-WHEEL OR TANDEM ROLLER.

**3.6 FINISH GRADING:**

- PERFORM ALL GRADING TO PROVIDE POSITIVE DRAINAGE AWAY FROM STRUCTURES AND SMOOTH, EVEN SURFACE DRAINAGE OF THE ENTIRE AREA WITHIN THE LIMITS OF CONSTRUCTION, GRADING SHALL BE COMPATIBLE WITH ALL SURROUNDING TOPOGRAPHY AND STRUCTURES.
  - UTILIZE SATISFACTORY FILL MATERIAL, RESULTING FROM THE EXCAVATION WORK IN THE CONSTRUCTION OF FILLS, EMBANKMENTS AND FOR REPLACEMENTS OF REMOVED UNSUITABLE MATERIALS.
  - ACHIEVE FINISHED GRADE BY PLACING A MINIMUM OF 4 INCHES OF 1/2" - 3/4" CRUSHED STONE ON TOP SOIL STABILIZER FABRIC.
  - REPAIR ALL ACCESS ROADS AND SURROUND AREAS USED DURING THE COURSE OF THIS WORK TO THEIR ORIGINAL CONDITION.
- 3.7 ASPHALT PAVING ROAD:**
- DIVISION 600 - KDOT FLEXIBLE PAVEMENT (UPDATE PER LOCAL DOT)
  - SECTION 403 - MODOT ASPHALT CONCRETE PAVEMENT.



**GENERAL DYNAMICS**  
Information Technology

1171 WEST 2400 SOUTH  
WEST VALLEY CITY, UT 84119

**Technology Associates  
EC Inc.**

**UTAH MARKET OFFICE**  
9847 SOUTH 500 WEST  
SANDY, UTAH 84070  
(801) 463-1020

REV	DATE	DESCRIPTION	BY
C	02/07/2013	ISSUED FOR 90% REVIEW	AC
B	01/21/2013	ISSUED FOR 90% REVIEW	JAA
A	12/03/2012	ISSUED FOR 90% REVIEW	JAA

IT IS A VIOLATION OF LAW FOR ANY PERSON, UNLESS THEY ARE ACTING UNDER THE DIRECTION OF A LICENSED PROFESSIONAL ENGINEER, TO ALTER THIS DOCUMENT.

NETWORK VISION MMBS LAUNCH  
**HUNTSVILLE**  
SL54XC068  
750 N. 7200 E.  
HUNTSVILLE, UT 84137

SHEET TITLE  
**GENERAL  
NOTES**

SHEET NUMBER  
**T-2**

NOTE: THE ORIGINAL SIZE OF THIS PLAN IS 24" X 36". SCALE RATIO IS NOT VALID FOR REDUCED OR ENLARGED SHEET SIZES

**ELECTRICAL NOTES:**

**PART 1 - GENERAL**

**1.1 GENERAL CONDITIONS:**

- A. CONTRACTOR SHALL INSPECT THE EXISTING SITE CONDITIONS PRIOR TO SUBMITTING BIDS. ANY QUESTIONS ARISING DURING THE BID PERIOD IN REGARDS TO THE SUBCONTRACTORS FUNCTIONS, THE SCOPE OF WORK, OR ANY OTHER ISSUE RELATED TO THIS PROJECT SHALL BE BROUGHT UP DURING THE BID PERIOD WITH THE PROJECT MANAGER FOR CLARIFICATION, NOT AFTER THE CONTRACT HAS BEEN AWARDED.
- B. THE SUBCONTRACTOR SHALL OBTAIN PERMITS, LICENSES, MAKE ALL DEPOSITS, AND PAY ALL FEES REQUIRED FOR THE CONSTRUCTION PERFORMANCE FOR THE WORK UNDER THIS SECTION.
- C. DRAWINGS SHOW THE GENERAL ARRANGEMENT OF ALL SYSTEMS AND COMPONENTS COVERED UNDER THIS SECTION. THE SUBCONTRACTOR SHALL VERIFY ALL DIMENSIONS. DRAWINGS SHALL NOT BE SCALED TO DETERMINED DIMENSIONS

**1.2 LAWS, REGULATIONS, ORDINANCES, STATUTES AND CODES.**

- A. ALL WORK SHALL BE INSTALLED IN ACCORDANCE WITH THE LATEST EDITION OF THE NATIONAL ELECTRICAL CODE, AND ALL APPLICABLE LOCAL LAWS, REGULATIONS, ORDINANCES, STATUTES AND CODES. CONDUIT BENDS SHALL BE THE RADIUS BEND FOR THE TRADE SIZE OF CONDUIT IN COMPLIANCE WITH THE LATEST EDITIONS OF NEC.

**1.3 REFERENCES:**

- A. THE PUBLICATIONS LISTED BELOW ARE PART OF THIS SPECIFICATION. EACH PUBLICATION SHALL BE THE LATEST REVISION AND ADDENDUM IN EFFECT ON THE DATE. THIS SPECIFICATION IS ISSUED FOR CONSTRUCTION UNLESS OTHERWISE NOTED. EXCEPT AS MODIFIED BY THE REQUIREMENT SPECIFIED HEREIN OR THE DETAILS OF THE DRAWINGS, WORK INCLUDED IN THIS SPECIFICATION SHALL CONFORM TO THE APPLICABLE PROVISION OF THESE PUBLICATIONS.

1. ANS/IEEE (AMERICAN NATIONAL STANDARDS INSTITUTE)
2. ASTM (AMERICAN SOCIETY FOR TESTING AND MATERIALS)
3. ICE (INSULATED CABLE ENGINEERS ASSOCIATION)
4. NEMA (NATIONAL ELECTRICAL MANUFACTURER'S ASSOCIATION)
5. NEPA (NATIONAL FIRE PROTECTION ASSOCIATION)
6. OSHA (OCCUPATIONAL SAFETY AND HEALTH ADMINISTRATION)
7. UL (UNDERWRITERS LABORATORIES, INC.)
8. SPRINT GROUNDING STANDARDS

**1.4 SCOPE OF WORK:**

- A. WORK UNDER THIS SECTION SHALL CONSIST OF FURNISHING ALL LABOR, MATERIAL, AND ASSOCIATED SERVICES REQUIRED TO COMPLETE REQUIRED CONSTRUCTION AND BE OPERATIONAL.
- B. ALL ELECTRICAL EQUIPMENT UNDER THIS CONTRACT SHALL BE PROPERLY TESTED, ADJUSTED, AND ALIGNED BY THE SUBCONTRACTOR.
- C. THE SUBCONTRACTOR SHALL BE RESPONSIBLE FOR ALL EXCAVATING, DRAINING, TRENCHING, BACKFILLING, AND REMOVAL OR EXCESS DIRT.
- D. THE SUBCONTRACTOR SHALL FURNISH TO THE OWNER WITH CERTIFICATES OF A FINAL INSPECTION AND APPROVAL FROM THE INSPECTION AUTHORITIES HAVING JURISDICTION.
- E. THE SUBCONTRACTOR SHALL PREPARE A COMPLETE SET OF AS-BUILT DRAWINGS, DOCUMENT ALL WIRING EQUIPMENT CONDITIONS, AND CHANGES WHILE COMPLETING THIS CONTRACT. THE AS-BUILT DRAWINGS SHALL BE SUBMITTED AT COMPLETION OF THE PROJECT.

**PART 2 - PRODUCTS**

**2.1 GENERAL:**

- A. ALL MATERIALS AND EQUIPMENT SHALL BE UL LISTED, NEW AND FREE FROM DEFECTS.
- B. ALL ITEMS OF MATERIALS AND EQUIPMENT SHALL BE ACCEPTABLE TO THE AUTHORITY HAVING JURISDICTION AS SUITABLE FOR THE USE INTENDED.
- C. ALL EQUIPMENT SHALL BEAR THE UNDERWRITERS LABORATORIES LABEL OR APPROVAL, AND SHALL CONFORM TO REQUIREMENT OF THE NATIONAL ELECTRICAL CODE.
- D. ALL OVER CURRENT DEVICES HAVE AN INTERRUPTING CURRENT RATING EQUAL TO OR GREATER THAN THE SHORT CIRCUIT CURRENT TO WHICH THEY ARE SUBJECTED, 10,000 AIC MINIMUM. VERIFY AVAILABLE SHORT CIRCUIT CURRENT DOES NOT EXCEED THE RATING OF ELECTRICAL EQUIPMENT.

**2.2 MATERIALS AND EQUIPMENT:**

- A. CONDUIT:
  1. RIGID METAL CONDUIT (RMC) SHALL BE HOT - DIPPED GALVANIZED INSIDE AND OUTSIDE INCLUDING ENDS AND THREADS AND ENAMELED OR LACQUERED IN ADDITION TO GALVANIZING.
  2. LIQUID TIGHT FLEXIBLE METAL CONDUIT SHALL BE UL LISTED.
  3. CONDUIT CLAMPS, STRAPS AND SUPPORTS SHALL BE STEEL OR MALLEABLE IRON. ALL FITTINGS SHALL BE COMPRESSION AND CONCRETE TIGHT TYPE. GROUNDING BUSHINGS WITH INSULATED PIVOTS SHALL BE INSTALLED ON ALL CONDUIT TERMINATIONS.
  4. NON-METALLIC CONDUIT AND FITTINGS SHALL BE SCHEDULE 40 PVC. INSTALL USING SOLVENT - CEMENT - TYPE JOINTS AS RECOMMENDED BY THE MANUFACTURER.
- B. CONDUCTORS AND CABLE:
  1. CONDUCTORS AND CABLE SHALL BE FLAME - RETARDANT, MOISTURE AND HEAT RESISTANT THERMOPLASTIC, SINGLE CONDUCTOR, COPPER, TYPE THHN/THWN-2, 600 VOLT, SIZE AS INDICATED, 12 AWG SHALL BE THE MINIMUM SIZE CONDUCTOR USED.
  2. 10 AWG AND SMALLER CONDUCTOR SHALL BE SOLID OR STRANDED AND 8 AWG AND LARGER CONDUCTOR SHALL BE STRANDED.
  3. SOLDERLESS, COMPRESSION - TYPE CONNECTORS SHALL BE USED FOR TERMINATION OF ALL STRANDED CONDUCTORS.
  4. STRAIN-RELIEF SUPPORTS GRIPS SHALL BE HUBBELL KELLEMS OR APPROVED EQUAL. CABLES SHALL BE SUPPORTED IN ACCORDANCE WITH THE NEC AND CABLE MANUFACTURER'S RECOMMENDATIONS.
  5. ALL CONDUCTORS SHALL BE TAGGED AT BOTH ENDS OF THE CONDUCTOR, AT ALL PULL BOXES, J-BOXES, EQUIPMENT AND CABINETS AND SHALL BE IDENTIFIED WITH APPROVED PLASTIC TAGS (ACTION CRAFT, BRADY, OR APPROVED EQUAL).

**C. DISCONNECT SWITCHES:**

- 1. DISCONNECT SWITCHES SHALL BE HEAVY DUTY, DEAD - FRONT, QUICK - MAKE, QUICK - BREAK, EXTERNALLY OPERABLE, HANDLE LOCKABLE AND INTERLOCK WITH COVER IN CLOSED POSITION, RATING AS INDICATED, UL LABELED FURNISHED IN NEMA 3R ENCLOSURE, SQUARE - D OR APPROVED EQUAL.

**D. CHEMICAL ELECTROLYTIC GROUNDING SYSTEM:**

1. INSTALL CHEMICAL GROUNDING AS REQUIRED. THE SYSTEM SHALL BE ELECTROLYTIC MAINTENANCE FREE ELECTRODE CONSISTING OF RODS WITH A MINIMUM OF 2 AWG CU EXOTHERMALLY WELDED PIGTAIL, PROTECTIVE BOXES, AND BACKFILL MATERIAL. MANUFACTURER SHALL BE LYNCOLE XIT GROUNDING ROD TYPES K2 - (\*)CS OR K2L-(\*)CS (\*) LENGTH AS REQUIRED.
2. GROUND ACCESS BOX SHALL BE A POLY-PLASTIC BOX FOR NON-TRAFFIC APPLICATIONS, INCLUDING BOLT DOWN FLUSH COVER WITH "BREATHER" HOLES. XIT MODEL #XB-22. ALL DISCONNECT SWITCHES AND CONTROLLING DEVICES SHALL BE PROVIDED WITH ENGRAVED LAMICOID NAMEPLATES INDICATING EQUIPMENT CONTROLLED, BRANCH CIRCUITS ID NUMBERING, AND THE ELECTRICAL POWER SOURCE.
3. BACKFILL MATERIAL SHALL BE LYNCONITE AND LYNCOLE GROUNDING GRAVEL.

**E. SYSTEM GROUNDING:**

1. ALL GROUNDING COMPONENTS SHALL BE TINNED AND GROUNDING CONDUCTOR SHALL BE 2 AWG BARE, SOLID, TINNED, COPPER, ABOVE GRADE GROUNDING CONDUCTORS SHALL BE INSULATED WHERE NOTED.
2. GROUNDING BUSES SHALL BE BARE, TINNED, ANNEALED COPPER BARS OF RECTANGULAR CROSS SECTION. STANDARD BUS BARS MGB, SHALL BE FURNISHED AND INSTALLED BY THE SUBCONTRACTOR. THEY SHALL NOT BE FABRICATED OR MODIFIED IN THE FIELD. ALL GROUNDING BUSES SHALL BE IDENTIFIED WITH MINIMUM 3/4" LETTERS BY WAY OF STENCILING OR DESIGNATION PLATE.
3. CONNECTORS SHALL BE HIGH - CONDUCTIVITY, HEAVY DUTY, LISTED AND LABELED AS GROUNDING CONNECTORS FOR THE MATERIALS USED. USE TWO - HOLD COMPRESSION LUGS WITH HEAT SHRINK FOR MECHANICAL CONNECTIONS.
4. EXOTHERMIC WELDED CONNECTIONS SHALL BE PROVIDED IN KIT FORM AND SELECTED FOR THE SPECIFIC TYPES, SIZES AND COMBINATIONS OF CONDUCTORS AND OTHER ITEMS TO BE CONNECTED.
5. GROUND RODS SHALL BE COPPER - CLAD STEEL WITH HIGH - STRENGTH STEEL CORE AND ELECTROLYTIC - GRADE COPPER OUTER SHEATH, MOLTEN WELDED TO CORE, 5/8" X 10'-0". ALL GROUNDING RODS SHALL BE INSTALLED WITH INSPECTION SLEEVES.
6. INSTALL AN EQUIPMENT GROUNDING CONDUCTOR IN ALL CONDUITS IN COMPLIANCE WITH THE SPECIFICATIONS AND NEC. THE EQUIPMENT GROUNDING CONDUCTORS SHALL BE BONDED AT ALL JUNCTION BOXES, DISCONNECT SWITCHES, STARTERS, AND EQUIPMENT CABINETS.

**F. OTHER MATERIALS:**

1. THE SUBCONTRACTOR SHALL PROVIDE OTHER MATERIALS, THOUGH NOT SPECIFICALLY DESCRIBED, WHICH ARE REQUIRED FOR A COMPLETELY OPERATIONAL SYSTEM AND PROPER INSTALLATION OF THE WORK.
2. PROVIDE PULL BOXES AND JUNCTION BOXES WHERE SHOWN OR REQUIRED BY NEC.

**G. PANELS AND LOAD CENTERS:**

1. ALL PANEL DIRECTORIES SHALL BE TYPEWRITTEN.

**PART 3 - EXECUTION**

**3.1 GENERAL**

- A. ALL MATERIAL AND EQUIPMENT SHALL BE INSTALLED IN STRICT ACCORDANCE WITH THE MANUFACTURER'S RECOMMENDATIONS.
- B. EQUIPMENT SHALL BE TIGHTLY COVERED AND PROTECTED AGAINST DIRT OR WATER, AND AGAINST CHEMICAL OR MECHANICAL INJURY DURING INSTALLATION AND CONSTRUCTION PERIODS.

**3.2 LABOR AND WORKMANSHIP:**

- A. ALL LABOR FOR THE INSTALLATION OF MATERIALS AND EQUIPMENT FURNISHED FOR THE ELECTRICAL SYSTEM SHALL BE INSTALLED BY EXPERIENCED WIRE MEN, IN A NEAT AND WORKMANLIKE MANNER.
- B. ALL ELECTRICAL EQUIPMENT SHALL BE ADJUSTED, ALIGNED AND TESTED BY THE SUBCONTRACTOR AS REQUIRED TO PRODUCE THE INTENDED PERFORMANCE.
- C. UPON COMPLETION OF WORK, THE SUBCONTRACTOR SHALL THOROUGHLY CLEAN ALL EXPOSED EQUIPMENT, REMOVE ALL LABELS AND ANY DEBRIS, CRATING, OR CARTONS AND LEAVE THE INSTALLATION FINISHED AND READY FOR OPERATION.

**3.3 COORDINATION:**

- A. THE SUBCONTRACTOR SHALL COORDINATE THE INSTALLATION OF ELECTRICAL ITEMS WITH THE OWNER - FURNISHED EQUIPMENT DELIVERY SCHEDULE TO PREVENT UNNECESSARY DELAYS IN THE TOTAL WORK.

**3.4 INSTALLATION:**

- A. CONDUIT:
  1. ALL ELECTRICAL WIRING SHALL BE INSTALLED IN CONDUIT AS SPECIFIED. NO CONDUIT OR TUBING OF LESS THAN 3/4 INCH TRADE SIZE.
  2. PROVIDE RIGID PVC SCHEDULE 80 CONDUITS FOR ALL RISERS, RMC OTHERWISE NOTED. EMT MAY BE INSTALLED FOR EXTERIOR CONDUITS WHERE NOT SUBJECT TO PHYSICAL DAMAGE.
  3. THE INSTALLATION OF SCHEDULE 40 PVC AND RMC CONDUITS SHALL BE 24 INCHES MINIMUM DEPTH. ALL 90 DEGREE BENDS SHALL BE RMC. EXPANSION JOINTS ARE REQUIRED ON ALL CONDUIT RISERS.
  4. USE GALVANIZED FLEXIBLE STEEL CONDUIT WHERE DIRECT CONNECTION TO EQUIPMENT WITH MOVEMENT, VIBRATION, OR FOR EASE OF MAINTENANCE. USE LIQUID TIGHT, FLEXIBLE METAL CONDUIT FOR OUTDOOR APPLICATIONS. INSTALL GALVANIZED FLEXIBLE STEEL CONDUIT AT ALL POINTS OF CONNECTION TO EQUIPMENT MOUNTED ON SUPPORT TO ALLOW FOR EXPANSION AND CONTRACTION.
  5. A RUN OF CONDUIT BETWEEN BOXES OR EQUIPMENT SHALL NOT CONTAIN MORE THAN THE EQUIVALENT OF THREE QUARTER-BENDS. CONDUIT BEND SHALL BE MADE WITH THE UL LISTED BENDER OR FACTORY 90 DEGREE ELBOWS MAY BE USED.
  6. FIELD FABRICATED CONDUITS SHALL BE CUT SQUARE WITH A CONDUIT CUTTING TOOL AND REAMED TO PROVIDE A SMOOTH INSIDE SURFACE.
  7. PROVIDE INSULATED GROUNDING BUSHING FOR ALL CONDUITS.
  8. SUBCONTRACTOR IS RESPONSIBLE FOR PROTECTING ALL CONDUITS DURING CONSTRUCTION. TEMPORARY OPENING IN THE CONDUIT SYSTEM SHALL BE PLUGGED OR CAPPED TO PREVENT ENTRANCE OF MOISTURE OR FOREIGN MATTER. SUBCONTRACTOR SHALL REPLACE ANY CONDUITS CONTAINING FOREIGN MATERIALS THAT CANNOT BE REMOVED.
  9. ALL CONDUITS SHALL BE SWABBED CLEAN BY PULLING AN APPROPRIATE SIZE MANDREL THROUGH THE CONDUIT BEFORE INSTALLATION OF CONDUCTORS OR CABLES. CONDUIT SHALL BE FREE OF DIRT AND DEBRIS.
  10. INSTALL PULL STRINGS IN ALL CLEAN EMPTY CONDUITS. IDENTIFY PULL STRINGS AT EACH END.
  11. INSTALL 2" HIGHLY VISIBLE AND DETECTABLE TAPE 12" ABOVE ALL UNDERGROUND CONDUITS AND CONDUCTORS.
  12. CONDUITS SHALL BE INSTALLED IN SUCH A MANNER AS TO INSURE AGAINST COLLECTION OF TRAPPED CONDENSATION.
  13. PROVIDE CORE DRILLING AS NECESSARY FOR PENETRATIONS TO ALLOW FOR RACEWAYS AND CABLES TO BE ROUTED THROUGH THE BUILDING. DO NOT PENETRATE STRUCTURAL MEMBERS. SLEEVES AND/OR PENETRATIONS IN FIRE RATED CONSTRUCTION SHALL BE EFFECTIVELY SEALED WITH FIRE RATED MATERIAL WHICH SHALL MAINTAIN THE FIRE RATING OF THE WALL OR STRUCTURE. FIRE STOPS AT FLOOR PENETRATIONS SHALL PREVENT PASSAGE OF WATER, SMOKE, FIRE, AND FUMES. ALL MATERIAL SHALL BE UL APPROVED FOR THIS PURPOSE.

**B. CONDUCTORS AND CABLE:**

1. ALL POWER WIRING SHALL BE COLOR CODED AS FOLLOWS:
 

<u>DESCRIPTION</u>	<u>208/240/120 VOLT SYSTEMS</u>
PHASE A .....	BLACK
PHASE B .....	RED
PHASE C .....	BLUE
NEUTRAL .....	WHITE
GROUNDING .....	GREEN
2. SPLICES SHALL BE MADE ONLY AT OUTLETS, JUNCTION BOXES, OR ACCESSIBLE RACEWAY CONDULETS APPROVED FOR THIS PURPOSE.
3. PULLING LUBRICANTS SHALL BE UL APPROVED. SHALL USE NYLON OR HEMP ROPE FOR PULLING CONDUCTOR OR CABLES INTO THE CONDUIT.
4. CABLES SHALL BE NEATLY TRAINED, WITHOUT INTERLACING, AND BE OF SUFFICIENT LENGTH IN ALL BOXES & EQUIPMENT TO PERMIT MAKING A NEAT ARRANGEMENT. CABLES SHALL BE SECURED IN A MANNER TO AVOID TENSION ON CONDUCTORS OF TERMINALS. CONDUCTORS SHALL BE PROTECTED FROM MECHANICAL INJURY AND MOISTURE. SHARP BENDS OVER CONDUIT BUSHINGS ARE PROHIBITED. DAMAGED CABLES SHALL BE REMOVED AND REPLACED AT THE SUBCONTRACTOR'S EXPENSE.

**C. DISCONNECT SWITCHES**

1. INSTALL DISCONNECT SWITCHES LEVEL AND PLUMB. CONNECT TO WIRING SYSTEM AND GROUNDING SYSTEM AS INDICATED.

**D. GROUNDING:**

1. ALL METALLIC PARTS OF ELECTRICAL EQUIPMENT WHICH DO NOT CARRY CURRENT SHALL BE GROUNDED IN ACCORDANCE WITH THE REQUIREMENTS OF THE BUILDING MANUFACTURER, SPRINT GROUNDING STANDARDS, AND THE NATIONAL ELECTRICAL CODE.
2. PROVIDE ELECTRICAL GROUNDING AND BONDING SYSTEM INDICATED WITH ASSEMBLY OF MATERIALS, INCLUDING GROUNDING ELECTRODES, BONDING JUMPERS AND ADDITIONAL ACCESSORIES AS REQUIRED FOR A COMPLETE INSTALLATION.
3. ALL GROUNDING CONDUCTORS SHALL PROVIDE A STRAIGHT DOWNWARD PATH TO GROUND WITH GRADUAL BEND AS REQUIRED. GROUNDING CONDUCTORS SHALL NOT BE LOOPED OR SHARPLY BENT. ROUTE GROUNDING CONNECTIONS AND CONDUCTORS TO GROUND IN THE SHORTEST AND STRAIGHTEST PATHS POSSIBLE TO MINIMIZE TRANSIENT VOLTAGE RISES.
4. BUILDINGS AND/OR NEW TOWERS GREATER THAN 75 FEET IN HEIGHT AND WHERE THE MAIN GROUNDING CONDUCTORS ARE REQUIRED TO BE ROUTED TO GRADE, THE SUBCONTRACTOR SHALL ROUTE TWO GROUNDING CONDUCTORS FROM THE ROOFTOP, TOWERS, AND WATER TOWERS GROUNDING RING, TO THE EXISTING GROUNDING SYSTEM, THE GROUNDING CONDUCTORS SHALL NOT BE SMALLER THAN 2/0 AWG COPPER. ROOFTOP GROUNDING RING SHALL BE BONDED TO THE EXISTING GROUNDING SYSTEM, THE BUILDING STEEL COLUMNS LIGHTNING PROTECTION SYSTEM, AND BUILDING MAIN WATER LINE (FERROUS OR NONFERROUS METAL PIPING ONLY).
5. TIGHTEN GROUNDING AND BONDING CONNECTORS, INCLUDING SCREWS, BOLTS, IN ACCORDANCE WITH MANUFACTURER'S PUBLISHED TORQUE TIGHTENING VALUES FOR CONNECTORS AND BOLTS. WHERE MANUFACTURER'S TORQUING REQUIREMENTS ARE NOT AVAILABLE, TIGHTEN CONNECTIONS TO COMPLY WITH TIGHTENING TORQUE VALUES SPECIFIED IN UL TO ASSURE PERMANENT AND EFFECTIVE GROUNDING.
6. SUBCONTRACTOR SHALL VERIFY THE LOCATIONS OF GROUNDING TIE-IN-POINTS TO THE EXISTING GROUNDING SYSTEM. ALL UNDERGROUND GROUNDING CONNECTIONS SHALL BE MADE BY THE EXOTHERMICWELD PROCESS AND INSTALLED IN ACCORDANCE WITH THE MANUFACTURER'S INSTRUCTIONS.
7. ALL GROUNDING CONNECTIONS SHALL BE INSPECTED FOR TIGHTNESS, EXOTHERMIC WELDED CONNECTIONS SHALL BE APPROVED BY THE INSPECTOR HAVING JURISDICTION BEFORE BEING PERMANENTLY CONCEALED.
8. APPLY CORROSION-RESISTANCE FINISH TO FIELD CONNECTIONS AND PLACES WHERE FACTORY APPLIED PROTECTIVE COATINGS HAVE BEEN DESTROYED. USE KOPR-SHIELD ANTI-OXIDATION COMPOUND ON ALL COMPRESSION GROUNDING CONNECTIONS.
9. A SEPARATE, CONTINUOUS, INSULATED EQUIPMENT GROUNDING CONDUCTOR SHALL BE INSTALLED IN ALL FEEDER AND BRANCH CIRCUITS.
10. BOND ALL INSULATED GROUNDING BUSHING WITH A BARE 6 AWG GROUNDING CONDUCTOR TO A GROUND BAR.
11. DIRECT BURIED GROUNDING CONDUCTORS SHALL BE INSTALLED AT A NOMINAL DEPTH OF 36" MINIMUM BELOW GRADE, OR 6" BELOW THE FROST LINE, USE GREATER OF THE TWO DISTANCES.
12. ALL GROUNDING CONDUCTORS EMBEDDED IN OR PENETRATING CONCRETE SHALL BE INSTALLED IN SCHEDULE 40 PVC CONDUIT.
13. THE INSTALLATION OF CHEMICAL ELECTROLYTIC GROUNDING SYSTEM IN STRICT ACCORDANCE WITH MANUFACTURER'S INSTRUCTIONS. REMOVE SEALING TAPE FROM LEACHING AND BREATHER HOLES. INSTALL PROTECTIVE BOX FLUSH WITH GRADE.
14. DRIVE GROUND RODS UNTIL TOPS ARE A MINIMUM DISTANCE OF 36" DEPTH OR 6" BELOW FROST LINE, USING THE GREATER OF THE TWO DISTANCES.
15. IF COAX ON THE ICE BRIDGE IS MORE THAN 6 FT. FROM THE GROUNDING BAR AT THE BASE OF THE TOWER, A SECOND GROUNDING BAR WILL BE NEEDED AT THE END OF THE ICE BRIDGE, TO GROUND THE COAX CABLE GROUNDING KITS AND IN-LINE ARRESTERS.
16. SUBCONTRACTORS SHALL REPAIR, AND/OR REPLACE EXISTING GROUNDING SYSTEM COMPONENTS DAMAGED DURING CONSTRUCTION AT THE SUBCONTRACTORS EXPENSE.

**3.5 ACCEPTANCE TESTING**

- A. CERTIFIED PERSONNEL USING CERTIFIED EQUIPMENT SHALL PERFORM REQUIRED TESTS AND SUBMIT WRITTEN TEST REPORTS UPON COMPLETION.
- B. WHEN MATERIAL AND/OR WORKMANSHIP IS FOUND NOT TO COMPLY WITH THE SPECIFIED REQUIREMENTS, THE NON-COMPLYING ITEMS SHALL BE REMOVED FROM THE PROJECT SITE AND REPLACED WITH ITEMS COMPLYING WITH THE SPECIFIED REQUIREMENTS PROMPTLY AFTER RECEIPT OF NOTICE FOR NON-COMPLIANCE.
- C. TEST PROCEDURES:
  1. ALL FEEDERS SHALL HAVE INSULATION TESTED AFTER INSTALLATION, BEFORE CONNECTION TO DEVICES. THE CONDUCTORS SHALL TEST FREE FROM SHORT CIRCUITS AND GROUNDS. TESTING SHALL BE FOR ONE MINUTE USING 1000V DC. PROVIDE WRITTEN DOCUMENTATION FOR ALL TESTS LISTED TO SUBCONTRACTOR.
  2. PRIOR TO ENERGIZING CIRCUITRY, TEST WIRING DEVICES FOR ELECTRICAL CONTINUITY AND PROPER POLARITY CONNECTIONS.
  3. MEASURE AND RECORD VOLTAGES BETWEEN PHASES AND BETWEEN PHASE CONDUCTORS AND NEUTRALS. SUBMIT A REPORT OF MAXIMUM AND MINIMUM VOLTAGES.
  4. PERFORM GROUNDING TEST TO MEASURE GROUNDING RESISTANCE OF GROUNDING SYSTEM USING THE IEEE STANDARD 3-POINT "FALL-OF-POTENTIAL" METHOD. PROVIDE PLOTTED TEST VALUES AND LOCATION SKETCH. NOTIFY THE ENGINEER IMMEDIATELY IF MEASURED VALUE IS OVER 5 OHMS.



**GENERAL DYNAMICS**  
Information Technology

1171 WEST 2400 SOUTH  
WEST VALLEY CITY, UT 84119

**Technology Associates  
EC Inc.**

**UTAH MARKET OFFICE**  
9847 SOUTH 500 WEST  
SANDY, UTAH 84070  
(801) 463-1020

REV	DATE	DESCRIPTION	BY
C	02/07/2013	ISSUED FOR 90% REVIEW	AC
B	01/21/2013	ISSUED FOR 90% REVIEW	JAA
A	12/03/2012	ISSUED FOR 90% REVIEW	JAA

IT IS A VIOLATION OF LAW FOR ANY PERSON, UNLESS THEY ARE ACTING UNDER THE DIRECTION OF A LICENSED PROFESSIONAL ENGINEER, TO ALTER THIS DOCUMENT.

NETWORK VISION MMBS LAUNCH

**HUNTSVILLE**  
**SL54XC068**  
750 N. 7200 E.  
HUNTSVILLE, UT 84137

SHEET TITLE  
**GENERAL  
NOTES**

SHEET NUMBER  
**T-3**

NOTE: THE ORIGINAL SIZE OF THIS PLAN IS 24" X 36". SCALE RATIO IS NOT VALID FOR REDUCED OR ENLARGED SHEET SIZES

**GENERAL NOTES**

- THIS FACILITY IS EXEMPT FROM HANDICAP REQUIREMENTS PER 2010 CBC SECTION 1105B.3.4 EXCEPTION #1. THIS FACILITY IS NON-OCCUPIABLE SPACE AND ENTERED ONLY BY SERVICE PERSONNEL. THIS SPACE IS NOT FOR HUMAN OCCUPANCY.
- THE CONTRACTOR SHALL VERIFY ALL EXISTING CONDITIONS AND DIMENSIONS PRIOR TO SUBMITTING HIS BID. ANY DISCREPANCIES, CONFLICTS OR OMISSIONS SHALL BE REPORTED TO THE ENGINEER PRIOR TO SUBMITTING BIDS, AND PROCEEDING WITH ANY WORK.
- THE CONTRACTOR SHALL NOTIFY ENGINEER OF ANY ERRORS, OMISSIONS, OR DISCREPANCIES AS THEY MAY BE DISCOVERED IN THE PLANS, SPECIFICATIONS, & NOTES PRIOR TO STARTING CONSTRUCTION. INCLUDING BUT NOT LIMITED BY DEMOLITION. THE CONTRACTOR SHALL BE RESPONSIBLE FOR CORRECTING ANY ERRORS, OMISSION, OR INCONSISTENCY AFTER THE START OF CONSTRUCTION WHICH HAS NOT BEEN BROUGHT TO THE ATTENTION OF THE ARCHITECT/ENGINEER AND SHALL INCUR ANY EXPENSES TO RECTIFY THE SITUATION. THE METHOD OF CORRECTION SHALL BE APPROVED BY THE ARCHITECT OR THE ENGINEER RESPONSIBLE OF THE PROJECT.
- PRIOR TO STARTING CONSTRUCTION, THE CONTRACTOR HAS THE RESPONSIBILITY TO LOCATE ALL EXISTING UTILITIES, WHETHER OR NOT SHOWN ON THE PLANS, AND TO PROTECT THEM FROM DAMAGE. THE CONTRACTOR OR SUBCONTRACTOR SHALL BEAR THE EXPENSE OF REPAIRING OR REPLACING ANY DAMAGE TO THE UTILITIES CAUSED DURING THE EXECUTION OF THE WORK. CONTACT USA DIG ALERT @ 811
- PRIOR TO STARTING CONSTRUCTION, THE CONTRACTOR SHALL PROTECT ALL AREAS FROM DAMAGE WHICH MAY OCCUR DURING CONSTRUCTION. ANY DAMAGE TO NEW OR EXISTING SURFACES, STRUCTURES OR EQUIPMENT SHALL BE IMMEDIATELY REPAIRED OR REPLACED TO THE SATISFACTION OF THE PROPERTY OWNER. THE CONTRACTOR SHALL BEAR THE EXPENSE OF REPAIRING OR REPLACING ANY DAMAGED AREAS.
- A COPY OF THE APPROVED PLANS SHALL BE KEPT IN A PLACE SPECIFIED BY THE GOVERNING AGENCY, AND BY LAW SHALL BE AVAILABLE FOR INSPECTION AT ALL TIMES. IT IS THE CONTRACTOR'S RESPONSIBILITY TO ENSURE ALL CONSTRUCTION SETS REFLECT THE SAME INFORMATION AS THE APPROVED PLANS. THE CONTRACTOR SHALL ALSO MAINTAIN ONE SET OF PLANS AT THE SITE FOR THE PURPOSE OF DOCUMENTING ALL AS-BUILT CHANGES, REVISIONS, ADDENDA, OR CHANGE ORDERS. THE CONTRACTOR SHALL FORWARD THE AS-BUILT/THIRD DRAWINGS TO THE ARCHITECT OR THE ENGINEER RESPONSIBLE OF THE PROJECT AT THE CONCLUSION OF THE PROJECT.
- THE CONTRACTOR SHALL BE RESPONSIBLE FOR THE COMPLETE SECURITY OF THE SITE WHILE THE WORK IS IN PROGRESS UNTIL THE JOB IS COMPLETE.
- THE CONTRACTOR IS RESPONSIBLE TO PROVIDE TEMPORARY POWER, WATER, AND TOILET FACILITIES AS REQUIRED BY THE PROPERTY OWNER OR GOVERNING AGENCY.
- ALL CONSTRUCTION THROUGH THE PROJECT SHALL CONFORM TO THE LATEST C.B.C. AND ALL OTHER GOVERNING CODES, INCLUDING THE CALIFORNIA ADMINISTRATIVE CODES TITLE 8, 19, AND 24. THE MOST RESTRICTIVE CODE SHALL GOVERN.
- THE CONTRACTOR AND SUBCONTRACTOR SHALL COMPLY WITH ALL LOCAL AND STATE REGULATIONS INCLUDING ALL OSHA REQUIREMENTS.
- WHEN REQUIRED STORAGE OF MATERIALS OCCURS, THEY SHALL BE EVENLY DISTRIBUTED OVER THE FLOOR OR ROOF SO AS NOT TO EXCEED THE DESIGNED LIVE LOADS FOR THE STRUCTURE. TEMPORARY SHORING OR BRACING SHALL BE PROVIDED WHERE THE STRUCTURE OR SOIL HAS NOT ATTAINED THE DESIGN STRENGTH FOR THE CONDITIONS PRESENT.
- THE CONTRACTOR SHALL SUPERVISE AND COORDINATE ALL WORK, USING HIS PROFESSIONAL KNOWLEDGE AND SKILLS. HE IS SOLELY RESPONSIBLE FOR ALL CONSTRUCTION MEANS, METHODS, TECHNIQUES, PROCEDURES AND SEQUENCING AND COORDINATING ALL PORTIONS OF THE WORK UNDER THE PROJECT.
- THE CONTRACTOR SHALL BE RESPONSIBLE TO OBTAIN AND PAY FOR ALL PERMITS, LICENSES AND INSPECTIONS WITH RESPECT TO THE WORK TO COMPLETE THE PROJECT. BUILDING PERMIT APPLICATIONS SHALL BE FILED BY THE OWNER OR AUTHORIZED AGENT. CONTRACTOR SHALL OBTAIN THE PERMIT AND MAKE FINAL PAYMENT OF SAID DOCUMENT.
- ALL DIMENSIONS TAKE PRECEDENCE OVER SCALE. DRAWINGS ARE NOT TO BE SCALED UNDER ANY CIRCUMSTANCES.
- THE CONTRACTOR SHALL PROVIDE ALL NECESSARY BLOCKING, BACKING, FRAMING, HANGERS, OR SUPPORTS FOR INSTALLATION OF ITEMS INDICATED ON THE DRAWINGS.
- THE CONTRACTOR SHALL PROVIDE THE FIRE MARSHALL OR U.L. APPROVED MATERIALS TO FILL/SEAL PENETRATIONS THROUGH FIRE RATED ASSEMBLIES.
- NEW CONSTRUCTION ADDED TO EXISTING CONSTRUCTION SHALL BE MATCHED IN FORM, TEXTURE, MATERIAL AND PAINT COLOR EXCEPT AS NOTED IN THE PLANS.
- THE CONTRACTOR IS TO PROVIDE PORTABLE FIRE EXTINGUISHERS HAVING A MINIMUM 2A:10-B-C RATING WITHIN 75FT. OF TRAVEL TO ALL PORTIONS OF THE CONSTRUCTION AREA. (2010 CFC SECTION 906.1-1 & 7 AND SECTION 906.3.1)
- MATERIALS TESTING SHALL BE TO THE LATEST STANDARDS AVAILABLE AS REQUIRED BY THE LOCAL GOVERNING AGENCY RESPONSIBLE FOR APPROVING THE RESULTS.
- ALL GENERAL NOTES AND STANDARD DETAILS ARE THE MINIMUM REQUIREMENTS TO BE USED IN CONDITIONS WHICH ARE NOT SPECIFICALLY SHOWN OTHERWISE.
- ALL DEBRIS AND REFUSE IS TO BE REMOVED FROM THE PROJECT. PREMISES SHALL BE LEFT IN A CLEAN BROOM FINISHED CONDITION AT ALL TIMES.
- BUILDING INSPECTORS AND/OR OTHER BUILDING OFFICIALS ARE TO BE NOTIFIED PRIOR TO ANY GRADING AND CONSTRUCTION EFFORT AS MANDATED BY THE GOVERNING AGENCY.
- ALL SYMBOLES AND ABBREVIATIONS ARE CONSIDERED CONSTRUCTION INDUSTRY STANDARDS. IF A CONTRACTOR HAS A QUESTION REGARDING THEIR EXACT MEANING THE ARCHITECT OR THE ENGINEER RESPONSIBLE OF THE PROJECT SHALL BE NOTIFIED FOR CLARIFICATIONS.

**GENERAL FIRE NOTES:**

- BUILDINGS UNDERGOING CONSTRUCTION, ALTERATION, OR DEMOLITION SHALL BE IN ACCORDANCE WITH 2010 CFC SECTION 1401 AND ALL GOVERNING CODES.
- ADDRESS SHALL BE PROVIDED FOR ALL NEW AND EXISTING BUILDINGS IN A POSITION AS TO BE PLAINLY VISIBLE AND LEGIBLE FROM THE STREET OR ROAD FRONTING THE PROPERTY. (2010 CFC SECTION 505.1)
- DECORATIVE MATERIALS SHALL BE MAINTAINED IN A FLAME-RETARDANT CONDITION. (2010 CFC SECTION 807-1.2)
- PORTABLE FIRE EXTINGUISHERS: AT LEAST ONE FIRE EXTINGUISHER WITH A MINIMUM RATING OF 2-A-10B-C SHALL BE PROVIDED WITHIN 75 FEET MAXIMUM TRAVEL DISTANCE FOR EACH 6,000 SQUARE FEET OR PORTION THEREOF ON EACH FLOOR. (2010 CFC SECTION 906.1.1 & 7 AND SECTION 906.3.1)

**ABBREVIATION**

A.B.  
ABV.  
ACCA  
ADD'L  
A.F.F.  
A.F.G.  
ALLUM.  
ALT.  
ANT.  
APPRX.  
ARCH.  
AWG.  
BLDG.  
BLK.  
BLKG.  
BM.  
B.N.  
BTCW.  
B.O.F.  
B/U  
CAB.  
CANT.  
C.I.P.  
CLG.  
CLR.  
COL.  
CONC.  
CONN.  
CONST.  
CONT.  
d  
DBL  
DEPT.  
D.F.  
DIA.  
DIAG.  
DIM.  
DWG.  
DWL.  
EA.  
EL.  
ELEC.  
ELEV.  
EMT.  
E.N.  
ENG.  
EQ.  
EXP.  
EXST.(E)  
EXT.

**DEFINITION**

ANCHOR BOLT  
ABOVE  
ANTENNA CABLE COVER ASSEMBLY  
ADDITIONAL  
ABOVE FINISHED FLOOR  
ABOVE FINISHED GRADE  
ALUMINIUM  
ALTERNATE  
ANTENNA  
APPROXIMATE(LY)  
ARCHITECT(URAL)  
AMERICAN WIRE GAUGE  
BUILDING  
BLOCK  
BLOCKING  
BEAM  
BOUNDARY NAILING  
BARE TINNED COPPER WIRE  
BOTTOM OF FOOTING  
BACK-UP CABINET  
CABINET  
CANTILEVER(ED)  
CAST IN PLACE  
CEILING  
CLEAR  
COLUMN  
CONCRETE  
CONNECTION(OR)  
CONSTRUCTION  
CONTINUOUS  
PENNY (NAILS)  
DOUBLE  
DEPARTMENT  
DOUGLAS FIR  
DIAMETER  
DIAGONAL  
DIMENSION  
DRAWING(S)  
DOWEL(S)  
EACH  
ELEVATION  
ELECTRICAL  
ELEVATOR  
ELECTRICAL METALLIC TUBING  
EDGE NAIL  
ENGINEER  
EQUAL  
EXPANSION  
EXISTING  
EXTERIOR

**ABBREVIATION**

FAB.  
F.F.  
F.G.  
FIN.  
FLR.  
FND.  
F.O.C.  
F.O.M.  
F.O.S.  
F.O.W.  
F.S.  
FT.(#)  
FTG.  
G.  
GA.  
GL.  
G.F.I.  
GLB.(GLU-LAM)  
GPS  
GRND.  
HDR.  
HGR.  
HT.  
ICGB.  
IN.(#)  
INT.  
LB.(#)  
L.B.  
L.F.  
L.  
MAS.  
MAX.  
M.B.  
MECH.  
MFR.  
MIN.  
MISC.  
MTL.  
(N)  
NO.(#)  
N.T.S.  
O.C.  
OPNG.  
P/C  
PCS  
PLY.  
PPC  
PRC  
P.S.F.  
P.S.I.  
P.T.

**DEFINITION**

FABRICATION(OR)  
FINISH FLOOR  
FINISH GRADE  
FINISH(ED)  
FLOOR  
FOUNDATION  
FACE OF CONCRETE  
FACE OF MASONRY  
FACE OF STUD  
FACE OF WALL  
FINISH SURFACE  
FOOT(FEET)  
FOOTING  
GROWTH (CABINET)  
GAUGE  
GALVANIZE(D)  
GROUND FAULT CIRCUIT INTERRUPTER  
GLUE LAMINATED BEAM  
GLOBAL POSITIONING SYSTEM  
GROUND  
HEADER  
HANGER  
HEIGHT  
ISOLATED COPPER GROUND BUS  
INCH(ES)  
INTERIOR  
POUND(S)  
LAG BOLTS  
LINEAR FEET (FOOT)  
LONG(ITUODINAL)  
MASONRY  
MAXIMUM  
MACHINE BOLT  
MECHANICAL  
MANUFACTURER  
MINIMUM  
MISCELLANEOUS  
METAL  
NEW  
NUMBER  
NOT TO SCALE  
ON CENTER  
OPENING  
PRECAST CONCRETE  
PERSONAL COMMUNICATION SERVICES  
PLYWOOD  
POWER PROTECTION CABINET  
PRIMARY RADIO CABINET  
POUNDS PER SQUARE FOOT  
POUNDS PER SQUARE INCH  
PRESSURE TREATED

**ABBREVIATION**

PWR.  
QTY.  
RAD.(R)  
REF.  
REINF.  
REQ'D.  
RGS.  
RRU.  
SCH.  
SHT.  
SIM.  
SPEC.  
SQ.  
S.S.  
STD.  
STL.  
STRUC.  
TEMP.  
THK.  
TMA  
T.N.  
T.O.A.  
T.O.C.  
T.O.F.  
T.O.P.  
T.O.S.  
T.O.W.  
TYP.  
U.G.  
U.L.  
U.N.O.  
V.I.F.  
W  
W/P.  
WT.  
E

**DEFINITION**

POWER (CABINET)  
QUANTITY  
RADIUS  
REFERENCE  
REINFORCEMENT(ING)  
REQUIRED  
RIGID GALVANIZED STEEL  
RADIO REMOTE UNIT  
SCHEDULE  
SHEET  
SIMILAR  
SPECIFICATION(S)  
SQUARE  
STAINLESS STEEL  
STANDARD  
STEEL  
STRUCTURAL  
TEMPORARY  
THICK(NESS)  
TOWER MOUNTED AMPLIFIER  
TOE NAIL  
TOP OF ANTENNA  
TOP OF CURB  
TOP OF FOUNDATION  
TOP OF PLATE (PARAPET)  
TOP OF STEEL  
TOP OF WALL  
TYPICAL  
UNDER GROUND  
UNDERWRITERS LABORATORY  
UNLESS NOTED OTHERWISE  
VERIFY IN FIELD  
WIDE(WIDTH)  
WITH  
WOOD  
WEATHERPROOF  
WEIGHT  
CENTERLINE  
PLATE

**ABBREVIATIONS**

	NEW ANTENNA		GRID REFERENCE		CENTERLINE
	EXISTING ANTENNA		DETAIL REFERENCE		PROPERTY/LEASE LINE
	GROUND ROD		ELEVATION REFERENCE		MATCH LINE
	GROUND BUS BAR		SECTION REFERENCE		WORK POINT
	MECHANICAL GRND. CONN.		GROUT OR PLASTER		GROUND CONDUCTOR
	CADWELD		(E) BRICK		TELEPHONE CONDUIT
	GROUND ACCESS WELL		(E) MASONRY		ELECTRICAL CONDUIT (POWER)
	ELECTRIC BOX		CONCRETE		COAXIAL CABLE
	TELEPHONE BOX		EARTH		OVERHEAD SERVICE CONDUCTORS
	LIGHT POLE		GRAVEL		CHAIN LINK FENCING
	FND. MONUMENT		PLYWOOD		
	SPOT ELEVATION		SAND		
	SET POINT		WOOD CONT.		
	REVISION		WOOD BLOCKING		
			STEEL		

2



**GENERAL DYNAMICS**  
Information Technology

1171 WEST 2400 SOUTH  
WEST VALLEY CITY, UT 84119

**Technology Associates**  
**EC Inc.**

**UTAH MARKET OFFICE**  
9847 SOUTH 500 WEST  
SANDY, UTAH 84070  
(801) 463-1020

REV	DATE	DESCRIPTION	BY
C	02/07/2013	ISSUED FOR 90% REVIEW	AC
B	01/21/2013	ISSUED FOR 90% REVIEW	JAA
A	12/03/2012	ISSUED FOR 90% REVIEW	JAA

IT IS A VIOLATION OF LAW FOR ANY PERSON, UNLESS THEY ARE ACTING UNDER THE DIRECTION OF A LICENSED PROFESSIONAL ENGINEER, TO ALTER THIS DOCUMENT.

NETWORK VISION MMBS LAUNCH  
**HUNTSVILLE**  
**SL54XC068**  
750 N. 7200 E.  
HUNTSVILLE, UT 84137

SHEET TITLE  
**GENERAL**  
**NOTES**

SHEET NUMBER  
**T-4**

NOTE: THE ORIGINAL SIZE OF THIS PLAN IS 24" X 36". SCALE RATIO IS NOT VALID FOR REDUCED OR ENLARGED SHEET SIZES

NOTE: THE ORIGINAL SIZE OF THIS PLAN IS 24" X 36". SCALE RATIO IS NOT VALID FOR REDUCED OR ENLARGED SHEET SIZES

EXISTING RAWLAND

EXISTING RAWLAND

N. 5475 E.

EXISTING ACCESS ROAD (TYP.)

EXISTING RAWLAND

**DISCLAIMER**  
 THESE DRAWINGS WERE PRODUCED WITHOUT THE BENEFIT OF A CURRENT LAND SURVEY. ALL PROPERTY LINES, EASEMENTS, AND SETBACKS SHALL BE VERIFIED PRIOR TO START OF CONSTRUCTION. TAIC DOES NOT GUARANTEE THE ACCURACY OF SAID PROPERTY LINES, EASEMENTS, ROADS AND SETBACKS.

SITE INFORMATION	
LATITUDE	41.27143 / 41° 16' 17.148" N
LONGITUDE	-111.77127 / 111° 46' 16.572" W
PARCEL NUMBER	21-008-0029 & 21-008-0036
AMSL / AGL	5076' / 111'-0"

1  
A-6

EXISTING SPRINT EQUIPMENT & ANTENNA AREA, FOR ENLARGED SITE PLAN SEE:

1  
A-2

1  
A-5

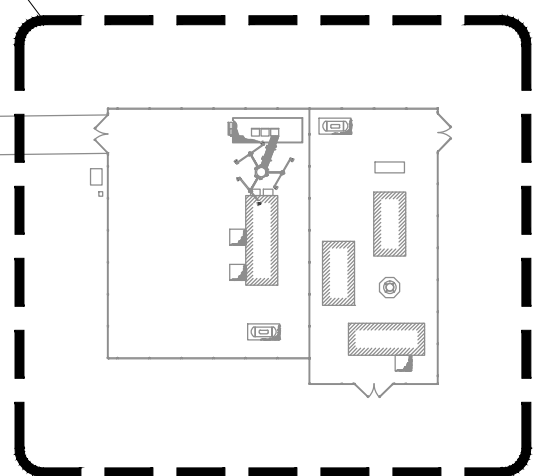

**GENERAL DYNAMICS**  
 Information Technology

1171 WEST 2400 SOUTH  
 WEST VALLEY CITY, UT 84119

**Technology Associates  
 EC Inc.**

**UTAH MARKET OFFICE**  
 9847 SOUTH 500 WEST  
 SANDY, UTAH 84070  
 (801) 463-1020

REV	DATE	DESCRIPTION	BY
C	02/07/2013	ISSUED FOR 90% REVIEW	AC
B	01/21/2013	ISSUED FOR 90% REVIEW	JAA
A	12/03/2012	ISSUED FOR 90% REVIEW	JAA

IT IS A VIOLATION OF LAW FOR ANY PERSON, UNLESS THEY ARE ACTING UNDER THE DIRECTION OF A LICENSED PROFESSIONAL ENGINEER, TO ALTER THIS DOCUMENT.

NETWORK VISION MMBS LAUNCH  
**HUNTSVILLE**  
 SL54XC068  
 750 N. 7200 E.  
 HUNTSVILLE, UT 84137

SHEET TITLE  
**OVERALL  
 SITE PLAN**

SHEET NUMBER  
**A-1**

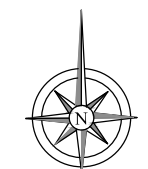

30' 0 15' 30' SCALE: 1" = 30'-0" (24x36)  
 (OR) 1/2" = 30'-0" (11x17)

1

**OVERALL SITE PLAN**



**GENERAL DYNAMICS**  
Information Technology

1171 WEST 2400 SOUTH  
WEST VALLEY CITY, UT 84119

**Technology Associates  
EC Inc.**

**UTAH MARKET OFFICE**  
9847 SOUTH 500 WEST  
SANDY, UTAH 84070  
(801) 463-1020

REV	DATE	DESCRIPTION	BY
C	02/07/2013	ISSUED FOR 90% REVIEW	AC
B	01/21/2013	ISSUED FOR 90% REVIEW	JAA
A	12/03/2012	ISSUED FOR 90% REVIEW	JAA

IT IS A VIOLATION OF LAW FOR ANY PERSON,  
UNLESS THEY ARE ACTING UNDER THE DIRECTION  
OF A LICENSED PROFESSIONAL ENGINEER,  
TO ALTER THIS DOCUMENT.

NETWORK VISION MMBS LAUNCH  
**HUNTSVILLE**  
SL54XC068  
750 N. 7200 E.  
HUNTSVILLE, UT 84137

SHEET TITLE  
**ENLARGED  
SITE PLAN**

SHEET NUMBER  
**A-2**

SITE INFORMATION	
LATITUDE	41.27143 / 41° 16' 17.148" N
LONGITUDE	-111.77127 / 111° 46' 16.572" W
PARCEL NUMBER	21-008-0029 & 21-008-0036
AMSL / AGL	5076' / 111'-0"

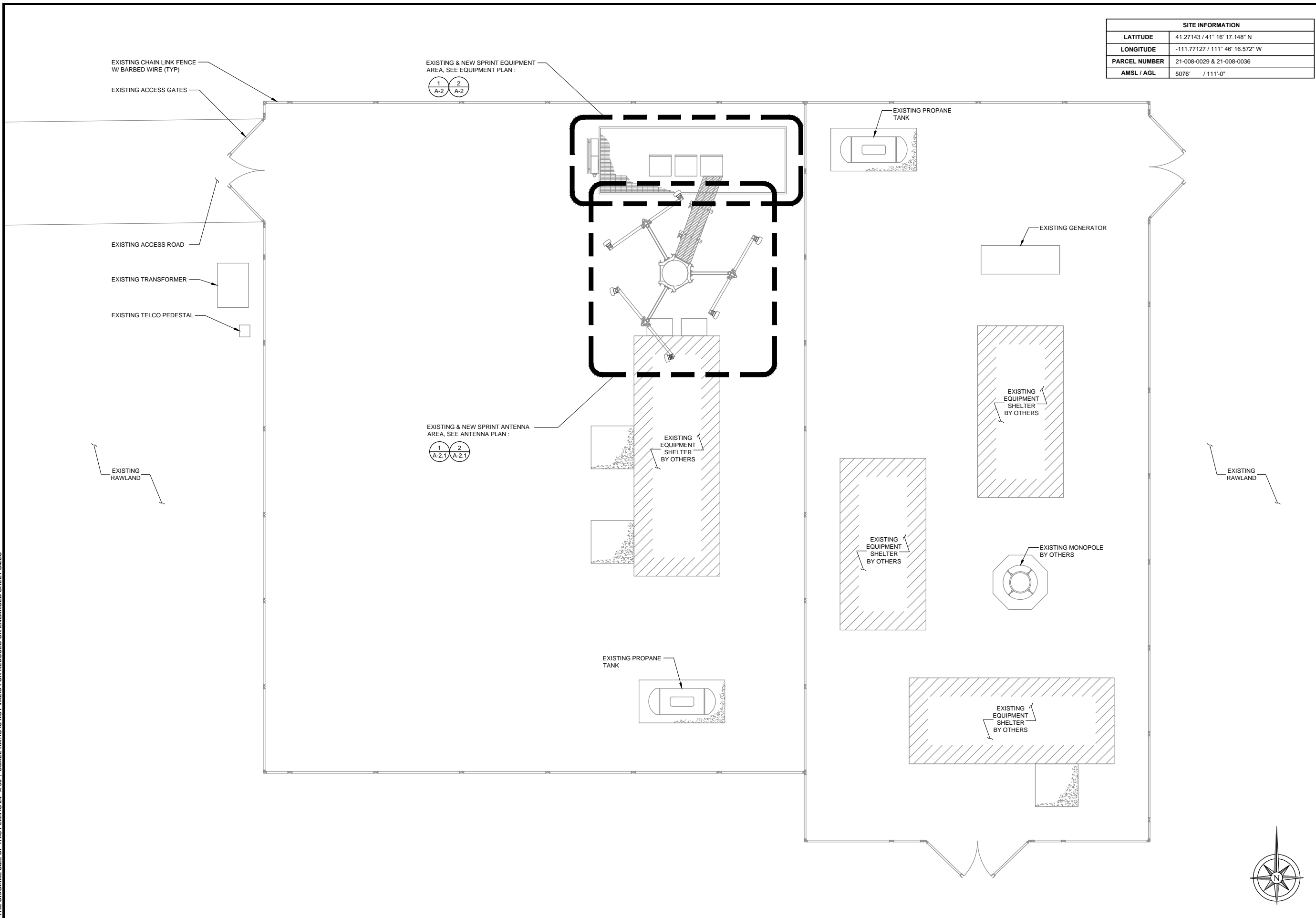

NOTE: THE ORIGINAL SIZE OF THIS PLAN IS 24" X 36". SCALE RATIO IS NOT VALID FOR REDUCED OR ENLARGED SHEET SIZES

**ENLARGED SITE PLAN**

0 2' 4' 8' SCALE: 1/8" = 1'-0" (24x36)  
(OR) 1/16" = 1'-0" (11x17)

1



NOTE: THE ORIGINAL SIZE OF THIS PLAN IS 24" X 36". SCALE RATIO IS NOT VALID FOR REDUCED OR ENLARGED SHEET SIZES

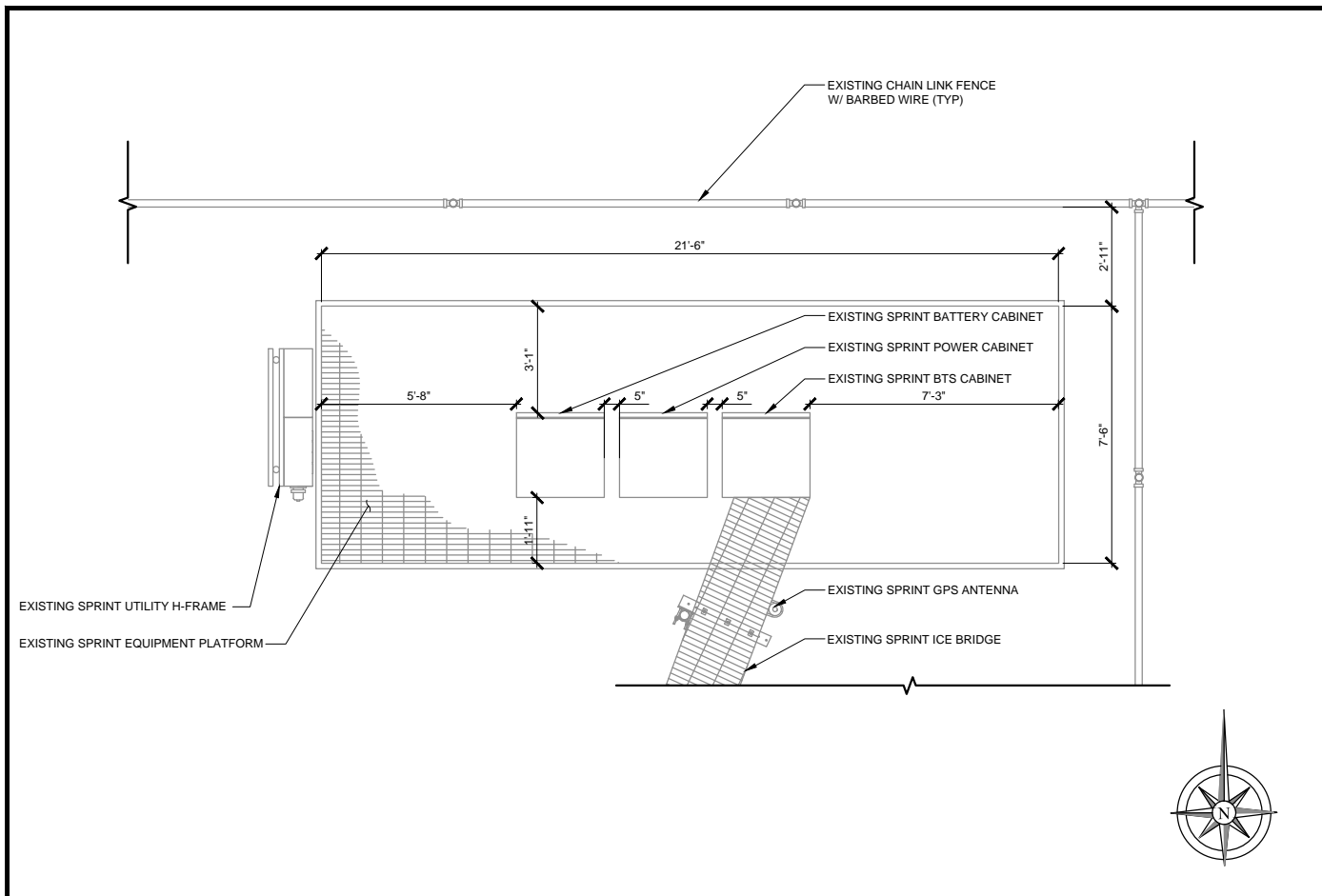

**EQUIPMENT PLAN (EXISTING)** SCALE: 3/8" = 1'-0" (24x36)  
(OR) 3/16" = 1'-0" (11x17) 1

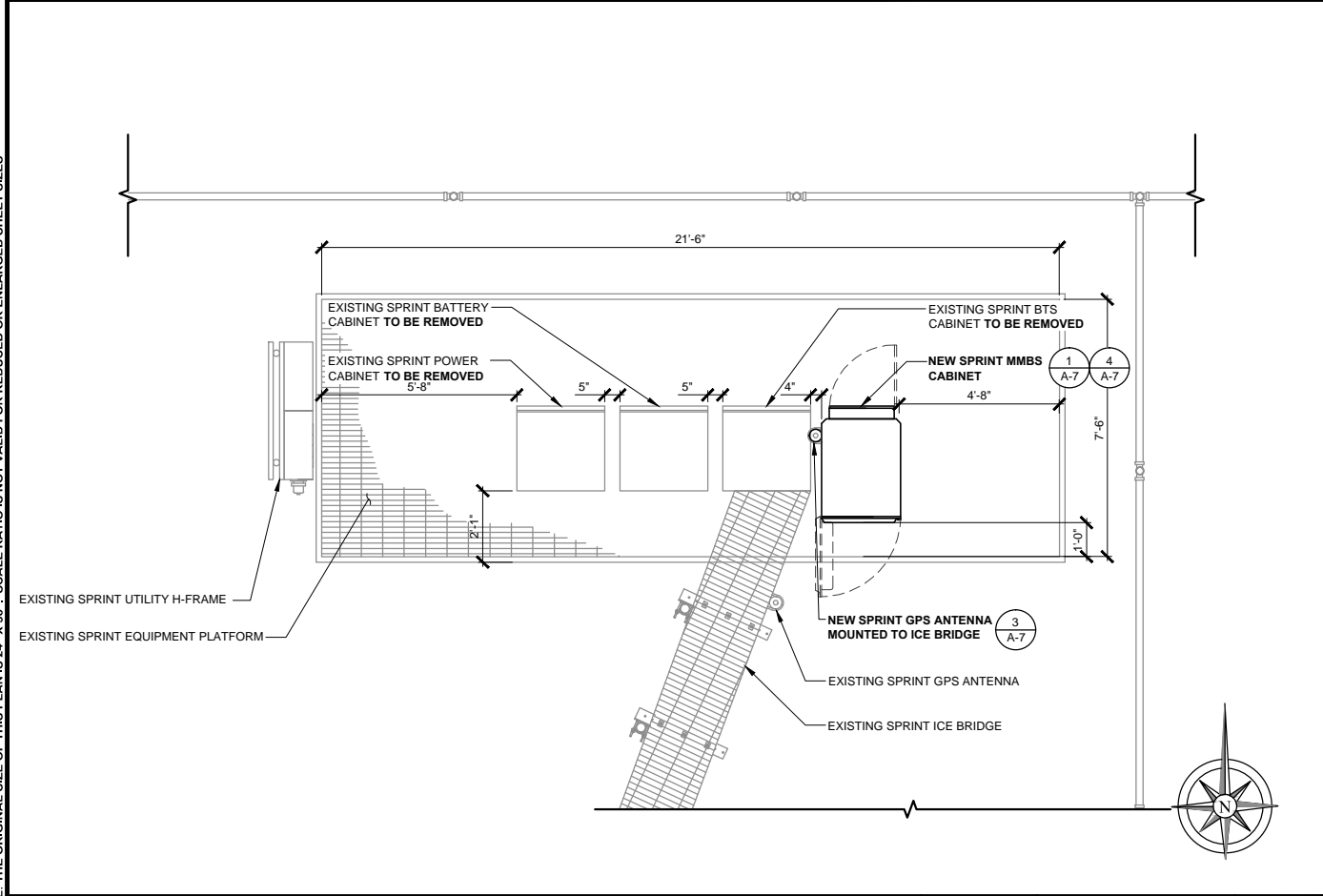

**EQUIPMENT PLAN (INTERIM)** SCALE: 3/8" = 1'-0" (24x36)  
(OR) 3/16" = 1'-0" (11x17) 2

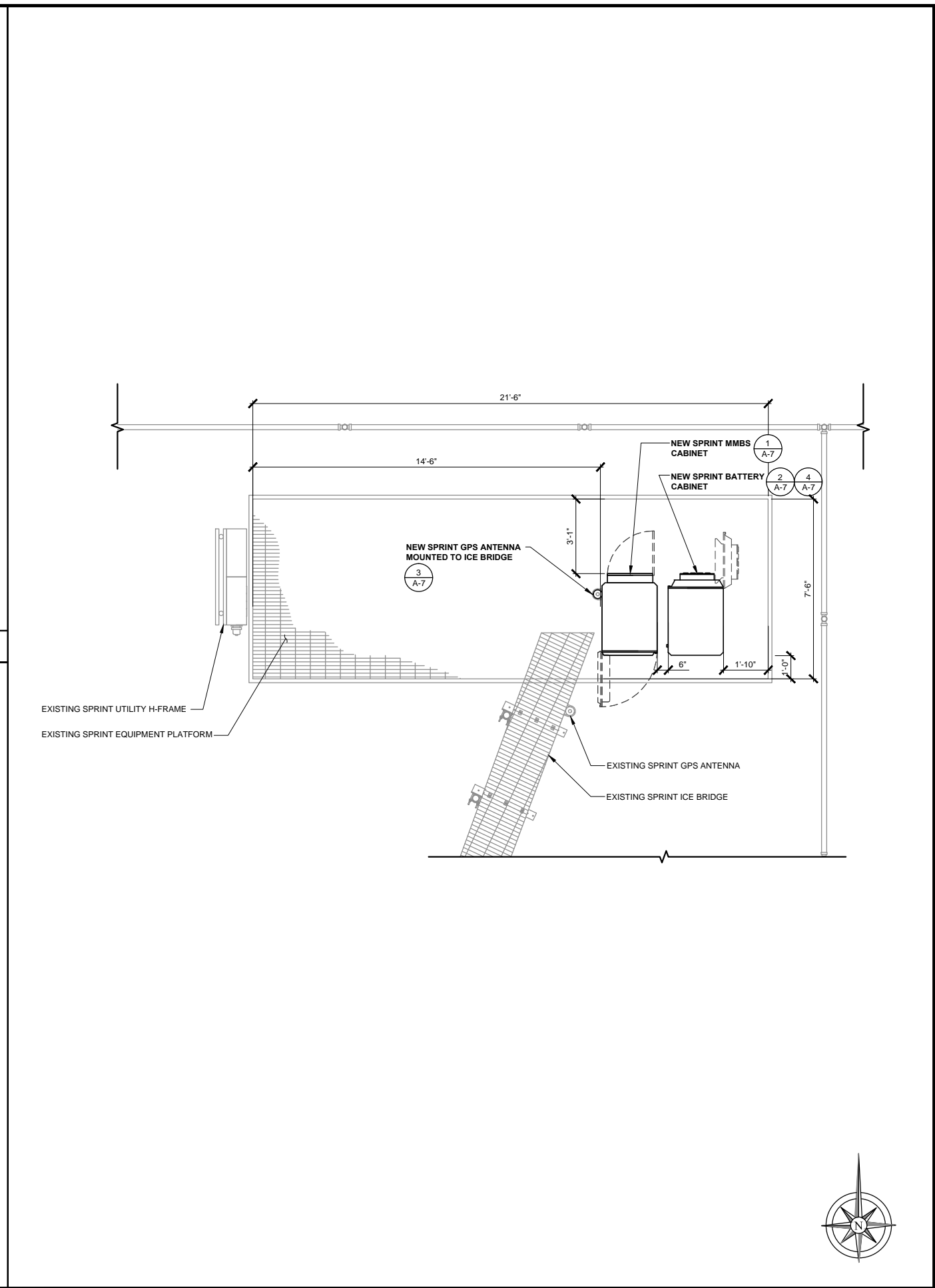

**EQUIPMENT PLAN (FINAL)** SCALE: 3/8" = 1'-0" (24x36)  
(OR) 3/16" = 1'-0" (11x17) 3

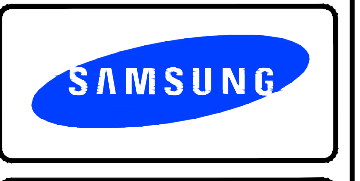

**GENERAL DYNAMICS**  
Information Technology  
  
1171 WEST 2400 SOUTH  
WEST VALLEY CITY, UT 84119

**Technology Associates  
EC Inc.**  
  
**UTAH MARKET OFFICE**  
9847 SOUTH 500 WEST  
SANDY, UTAH 84070  
(801) 463-1020

REV	DATE	DESCRIPTION	BY
C	02/07/2013	ISSUED FOR 90% REVIEW	AC
B	01/21/2013	ISSUED FOR 90% REVIEW	JAA
A	12/03/2012	ISSUED FOR 90% REVIEW	JAA

IT IS A VIOLATION OF LAW FOR ANY PERSON, UNLESS THEY ARE ACTING UNDER THE DIRECTION OF A LICENSED PROFESSIONAL ENGINEER, TO ALTER THIS DOCUMENT.

NETWORK VISION MMBS LAUNCH  
**HUNTSVILLE**  
SL54XC068  
750 N. 7200 E.  
HUNTSVILLE, UT 84137

SHEET TITLE  
**EQUIPMENT  
PLANS**

SHEET NUMBER  
**A-3**

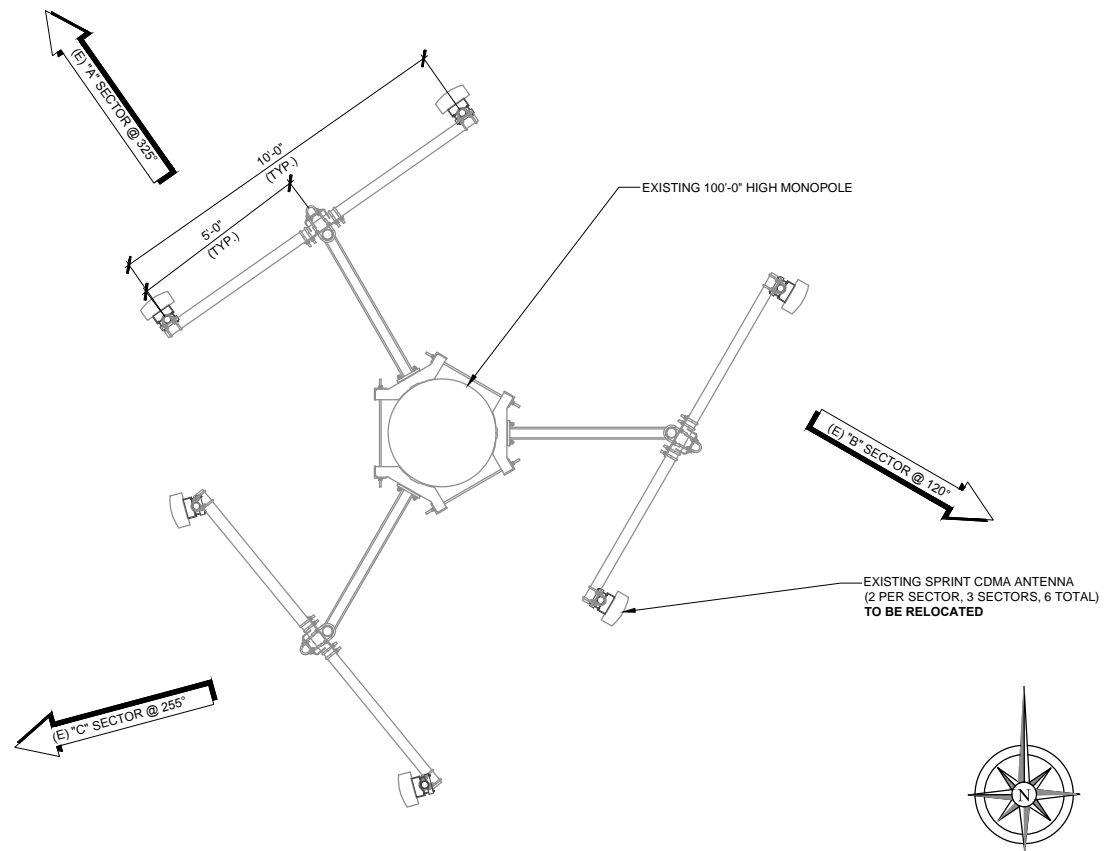

ANTENNA PLAN (EXISTING)

0 1' 2' 3' SCALE: 3/8" = 1'-0" (24x36)  
(OR) 3/16" = 1'-0" (11x17) 1

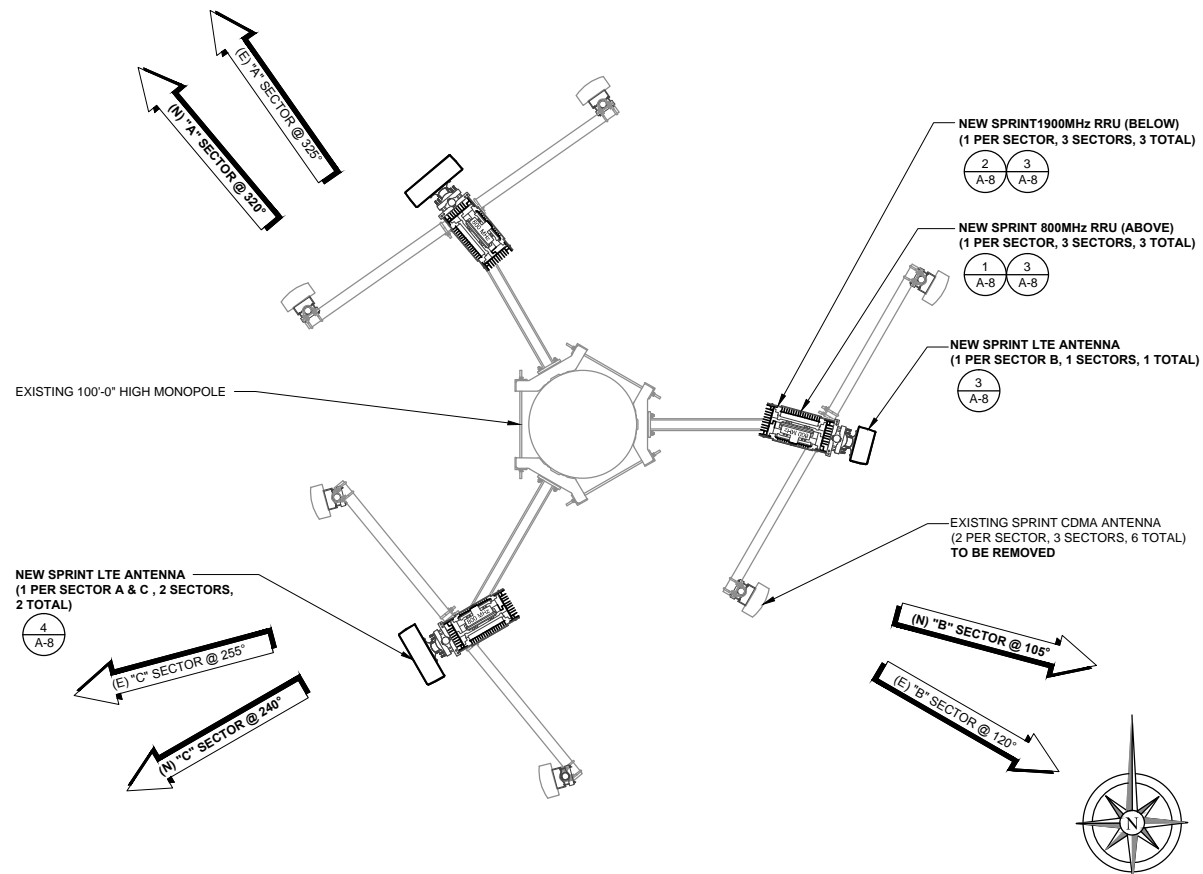

ANTENNA PLAN (INTERIM)

0 1' 2' 3' SCALE: 3/8" = 1'-0" (24x36)  
(OR) 3/16" = 1'-0" (11x17) 2

ANTENNA SCHEDULE										
SECTOR	ANTENNA FREQUENCY	ANTENNA MANUFACTURER	ANTENNA MODEL	ANTENNA QUANTITY	AZIMUTH	RAD CENTER	ANTENNA SIZE	1900 ELECT. TILT	800 ELECT. TILT	MECH. TILT
ALPHA	800/1900 MHz	POWERWAVE	P40-16-XLPP-RR	1 (PER SECTOR)	320°	85'-0"	4'-6"	0°	0°	0°
BETA	800/1900 MHz	RFS	APXV9ERR18-C-120	1 (PER SECTOR)	105°	85'-0"	6'-0"	-2°	-1°	-1°
GAMMA	800/1900 MHz	POWERWAVE	P40-16-XLPP-RR	1 (PER SECTOR)	240°	85'-0"	4'-6"	-2°	0°	0°

RRU / HYBRID CABLE SCHEDULE									
SECTOR	RRU MODEL	RRU FREQUENCY	HYBRID CABLE LENGTH & TYPE & QTY.	JUMPER SIZE	JUMPER LENGTH	RET LENGTH	RET CABLE MANUFACTURER	RET CABLE MODEL NUMBER	
ALPHA	RRU-C2A & RRU-P4	(1)800MHz & (1)1900MHz	150' / 2 / 1	1/2"	6'	9.8'	COMMSCOPE	iRET AISGv1.1	
BETA	RRU-C2A & RRU-P4	(1)800MHz & (1)1900MHz	150' / 2 / 1	1/2"	6'	9.8'	COMMSCOPE	iRET AISGv1.1	
GAMMA	RRU-C2A & RRU-P4	(1)800MHz & (1)1900MHz	150' / 2 / 1	1/2"	6'	9.8'	COMMSCOPE	iRET AISGv1.1	

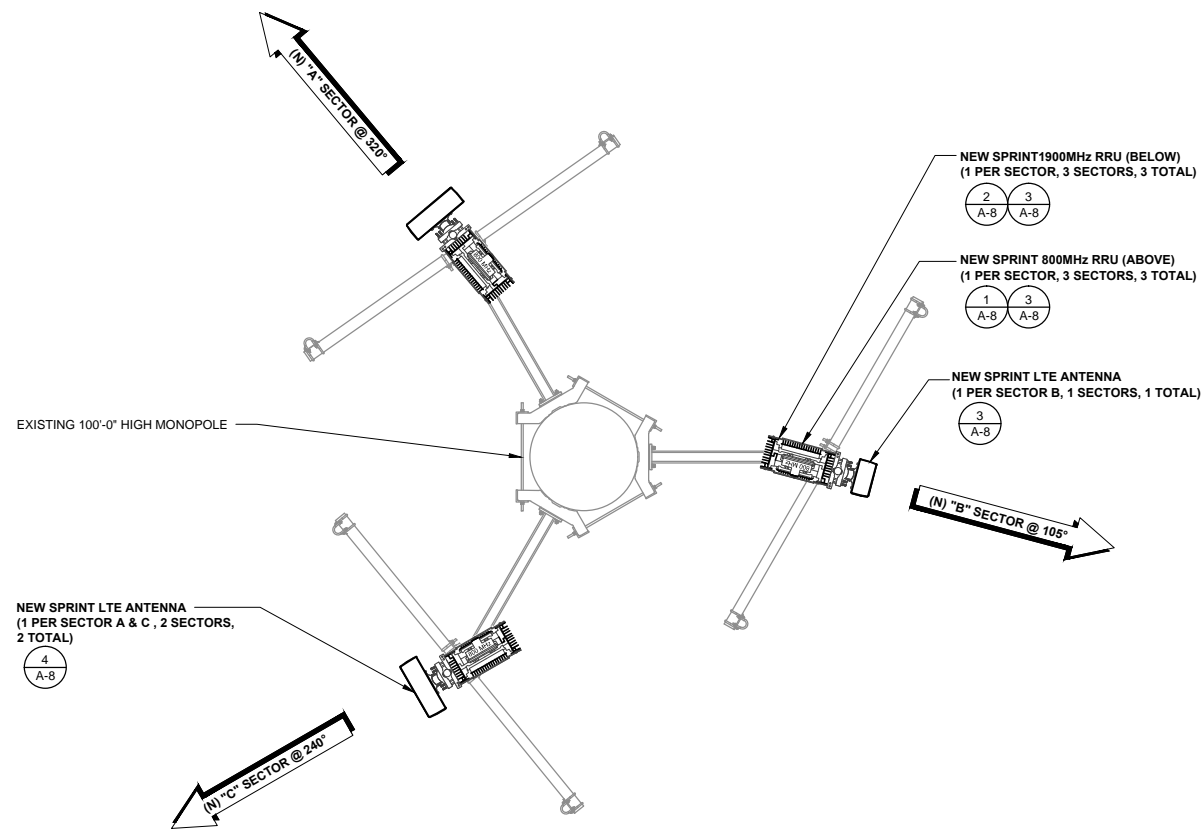

ANTENNA PLAN (FINAL)

3



GENERAL DYNAMICS  
Information Technology

1171 WEST 2400 SOUTH  
WEST VALLEY CITY, UT 84119

Technology Associates  
EC Inc.

UTAH MARKET OFFICE

9847 SOUTH 500 WEST  
SANDY, UTAH 84070  
(801) 463-1020

REV	DATE	DESCRIPTION	BY
C	02/07/2013	ISSUED FOR 90% REVIEW	AC
B	01/21/2013	ISSUED FOR 90% REVIEW	JAA
A	12/03/2012	ISSUED FOR 90% REVIEW	JAA

IT IS A VIOLATION OF LAW FOR ANY PERSON,  
UNLESS THEY ARE ACTING UNDER THE DIRECTION  
OF A LICENSED PROFESSIONAL ENGINEER,  
TO ALTER THIS DOCUMENT.

NETWORK VISION MMBS LAUNCH

HUNTSVILLE

SL54XC068

750 N. 7200 E.  
HUNTSVILLE, UT 84137

SHEET TITLE  
ANTENNA  
PLANS

SHEET NUMBER

A-4

NOTE: THE ORIGINAL SIZE OF THIS PLAN IS 24" X 36". SCALE RATIO IS NOT VALID FOR REDUCED OR ENLARGED SHEET SIZES





GENERAL DYNAMICS  
Information Technology

1171 WEST 2400 SOUTH  
WEST VALLEY CITY, UT 84119

Technology Associates  
EC Inc.

UTAH MARKET OFFICE  
9847 SOUTH 500 WEST  
SANDY, UTAH 84070  
(801) 463-1020

REV	DATE	DESCRIPTION	BY
C	02/07/2013	ISSUED FOR 90% REVIEW	AC
B	01/21/2013	ISSUED FOR 90% REVIEW	JAA
A	12/03/2012	ISSUED FOR 90% REVIEW	JAA

IT IS A VIOLATION OF LAW FOR ANY PERSON,  
UNLESS THEY ARE ACTING UNDER THE DIRECTION  
OF A LICENSED PROFESSIONAL ENGINEER,  
TO ALTER THIS DOCUMENT.

NETWORK VISION MMBS LAUNCH  
HUNTSVILLE  
SL54XC068  
750 N. 7200 E.  
HUNTSVILLE, UT 84137

SHEET TITLE  
WEST  
ELEVATION

SHEET NUMBER  
A-5

NOTE:  
EXISTING & FINAL CONFIGURATIONS ARE SHOWN; FOR  
TEMPORARY / INTERIM CONFIGURATIONS SEE ANTENNA PLANS.

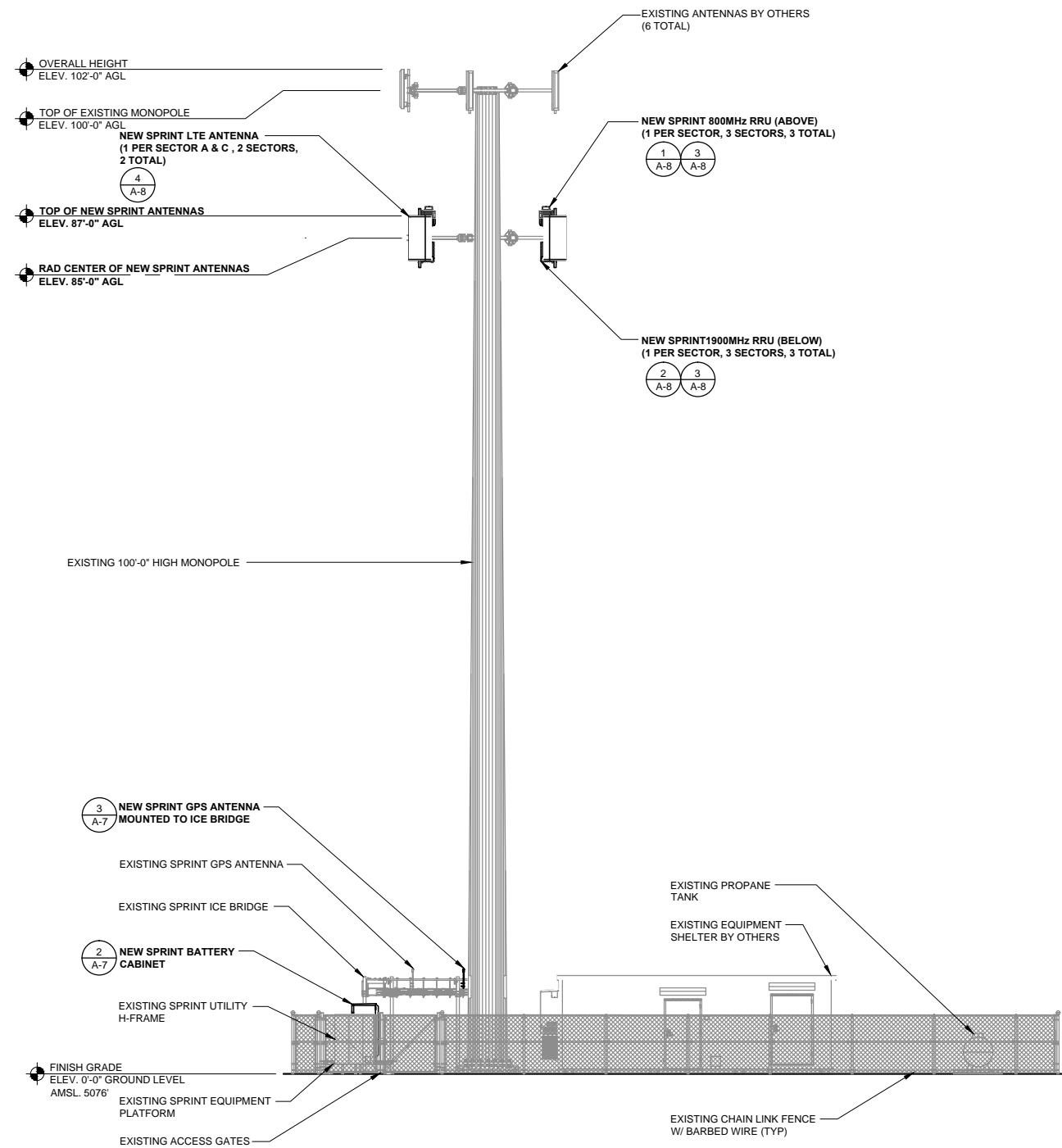
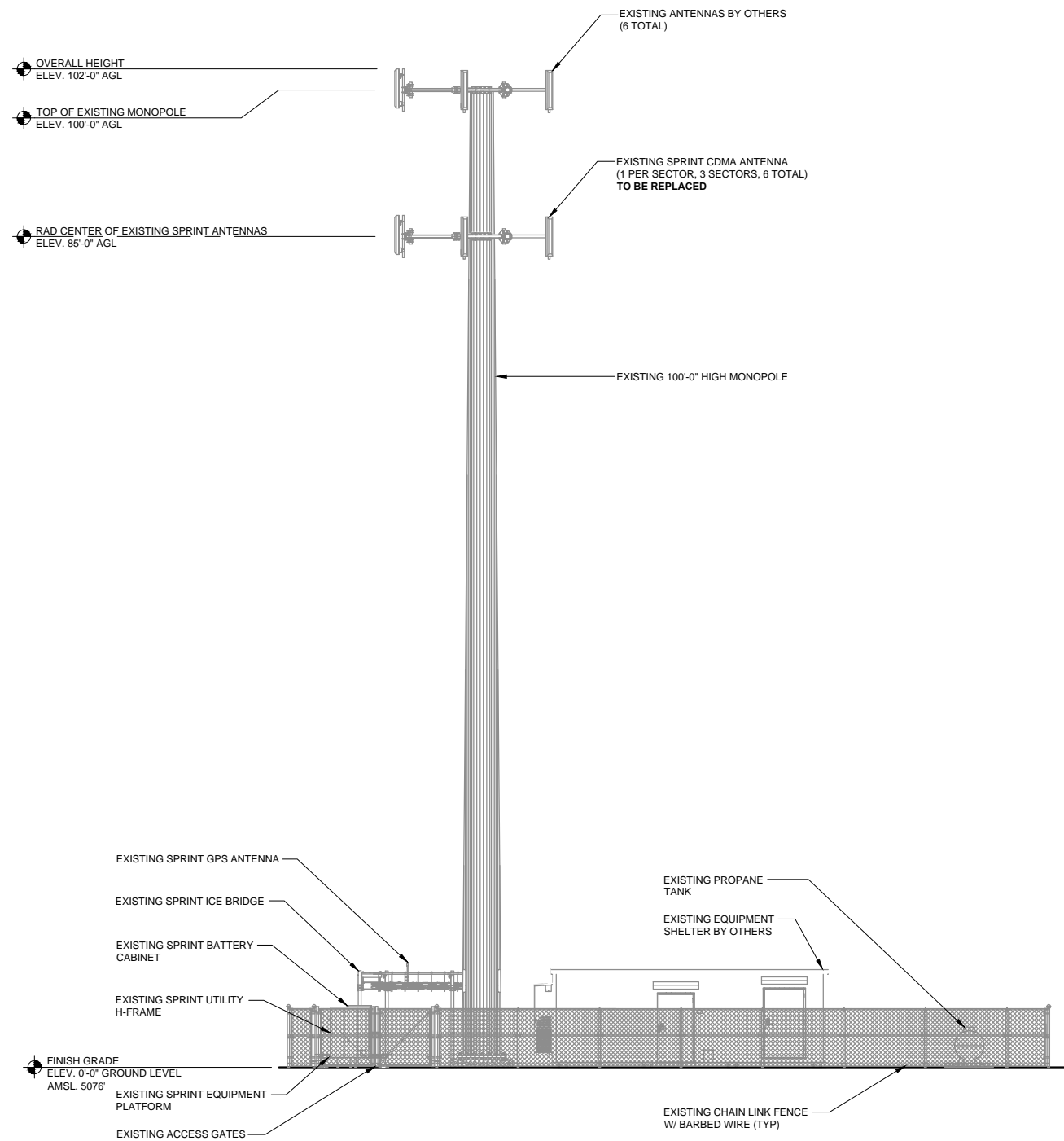

NOTE: THE ORIGINAL SIZE OF THIS PLAN IS 24" X 36". SCALE RATIO IS NOT VALID FOR REDUCED OR ENLARGED SHEET SIZES

WEST ELEVATION (EXISTING)

SCALE: 1/8" = 1'-0" (24x36)  
(OR) 1/16" = 1'-0" (11x17)

1

WEST ELEVATION (FINAL)

SCALE: 1/8" = 1'-0" (24x36)  
(OR) 1/16" = 1'-0" (11x17)

2



GENERAL DYNAMICS  
Information Technology

1171 WEST 2400 SOUTH  
WEST VALLEY CITY, UT 84119

Technology Associates  
EC Inc.

UTAH MARKET OFFICE

9847 SOUTH 500 WEST  
SANDY, UTAH 84070  
(801) 463-1020

REV	DATE	DESCRIPTION	BY
C	02/07/2013	ISSUED FOR 90% REVIEW	AC
B	01/21/2013	ISSUED FOR 90% REVIEW	JAA
A	12/03/2012	ISSUED FOR 90% REVIEW	JAA

IT IS A VIOLATION OF LAW FOR ANY PERSON,  
UNLESS THEY ARE ACTING UNDER THE DIRECTION  
OF A LICENSED PROFESSIONAL ENGINEER,  
TO ALTER THIS DOCUMENT.

NETWORK VISION MMBS LAUNCH

HUNTSVILLE  
SL54XC068  
750 N. 7200 E.  
HUNTSVILLE, UT 84137

SHEET TITLE  
NORTH  
ELEVATION

SHEET NUMBER  
**A-6**

NOTE:  
EXISTING & FINAL CONFIGURATIONS ARE SHOWN; FOR  
TEMPORARY / INTERIM CONFIGURATIONS SEE ANTENNA PLANS.

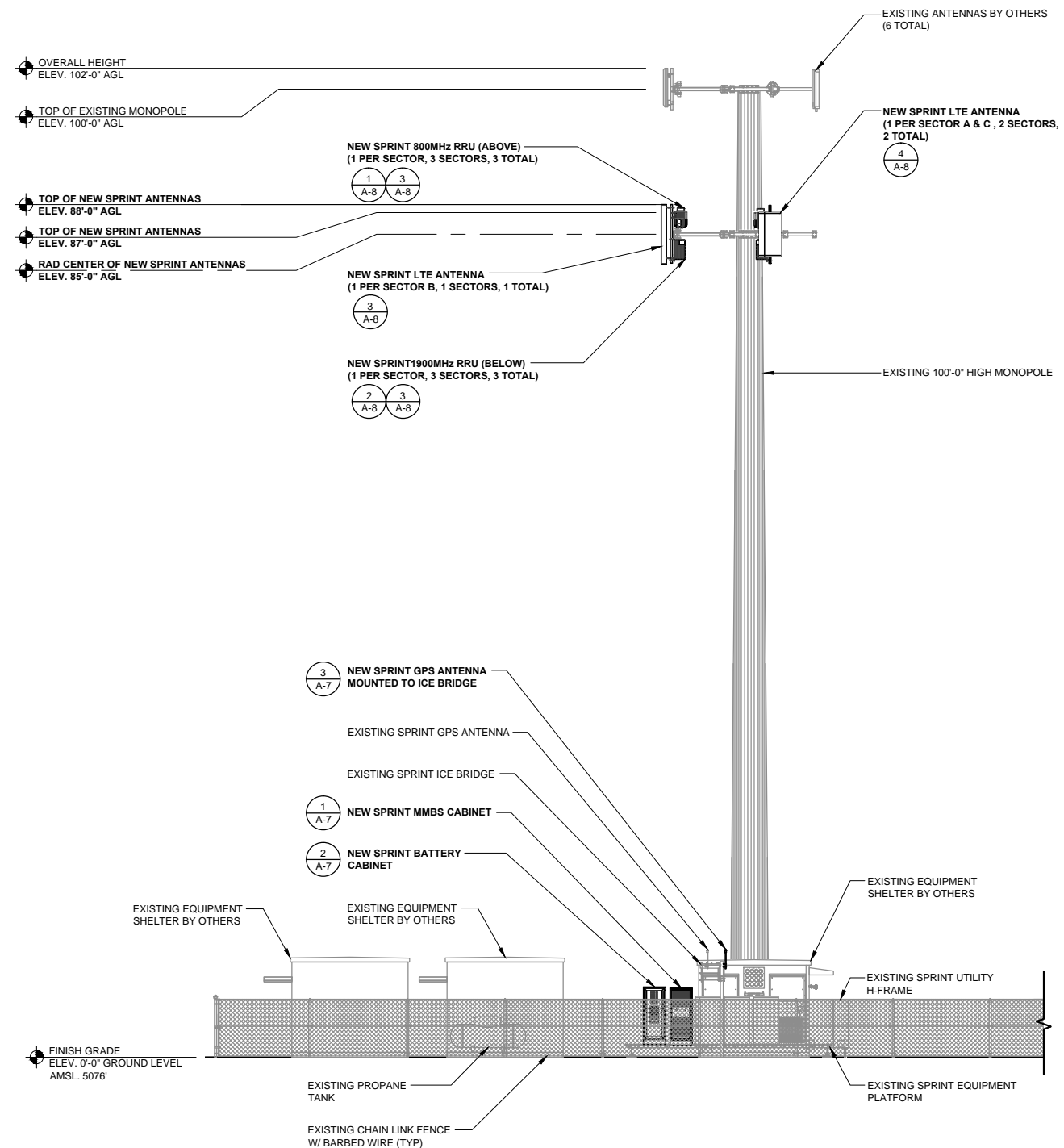
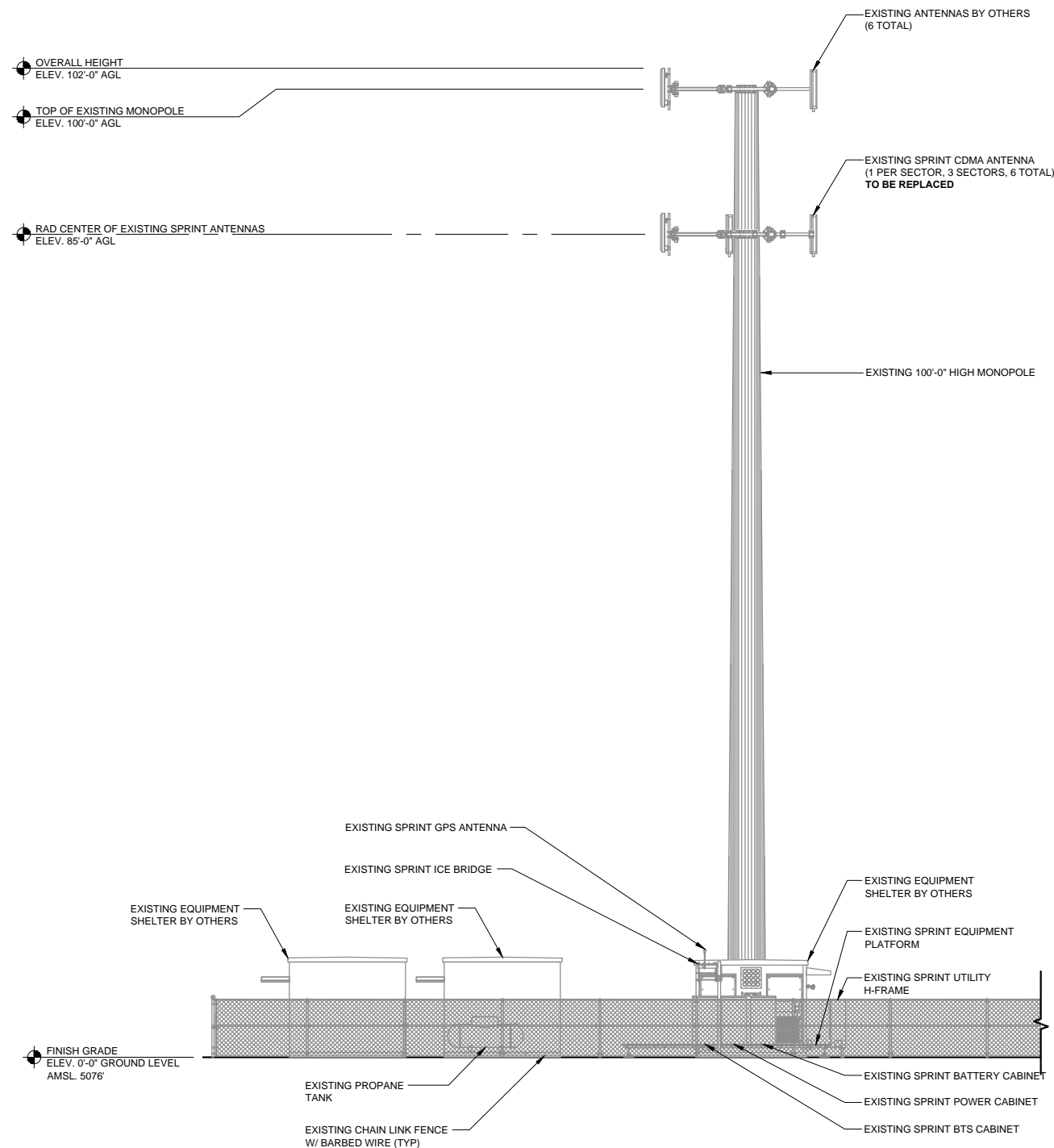

NOTE: THE ORIGINAL SIZE OF THIS PLAN IS 24" X 36". SCALE RATIO IS NOT VALID FOR REDUCED OR ENLARGED SHEET SIZES

**NORTH ELEVATION (EXISTING)**

SCALE: 1/8" = 1'-0" (24x36)  
(OR) 1/16" = 1'-0" (11x17)

1

**NORTH ELEVATION (FINAL)**

SCALE: 1/8" = 1'-0" (24x36)  
(OR) 1/16" = 1'-0" (11x17)

2

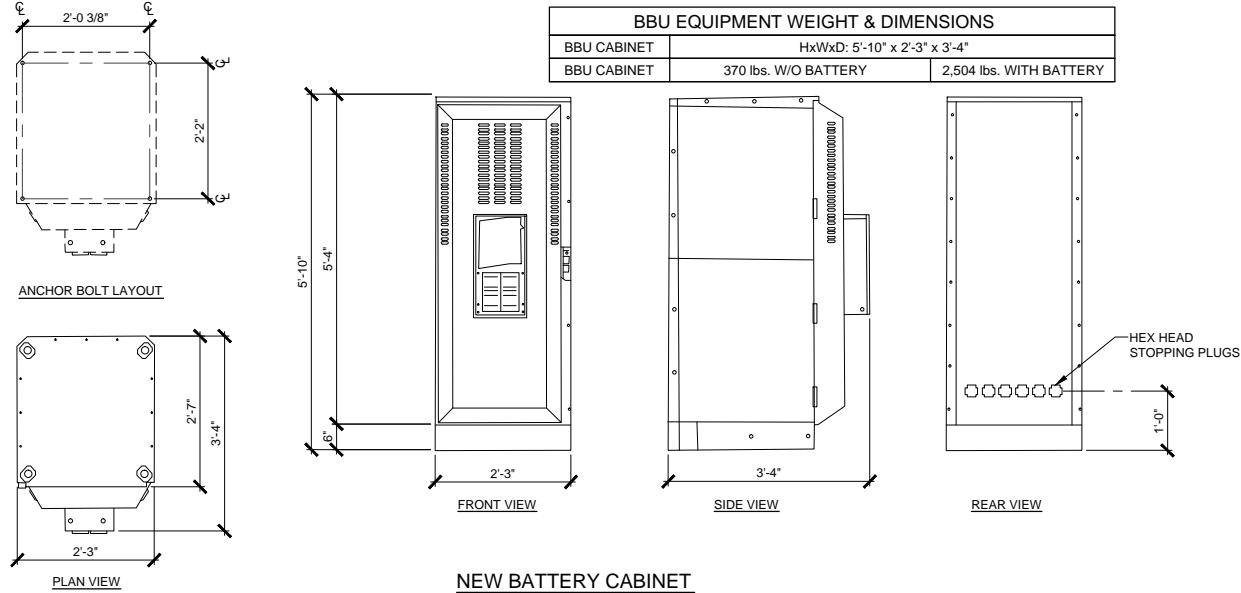
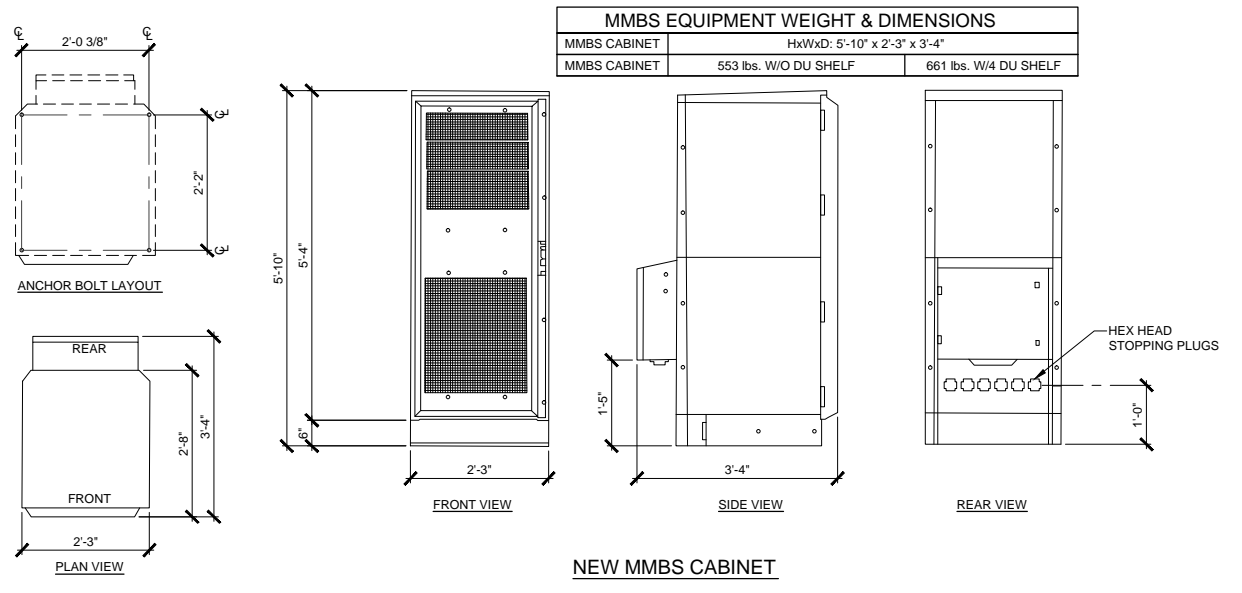

**BATTERY CABINET SPECIFICATIONS** SCALE N.T.S. 2

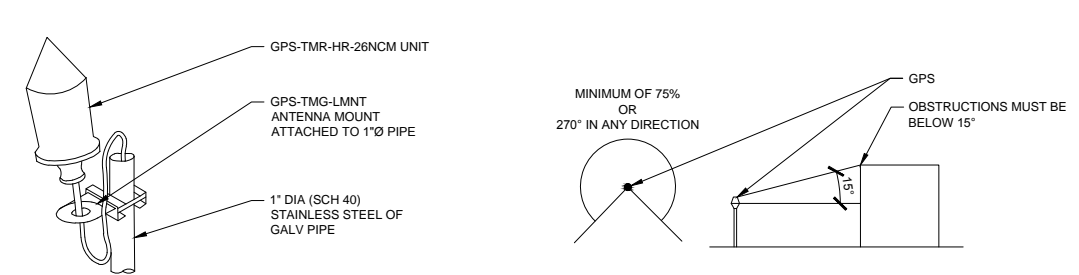

- NOTES**
- THE GPS ANTENNA MOUNT IS DESIGNED TO FASTEN TO A STANDARD 1", SCH. 40, GALVANIZED STEEL OF STAINLESS STEEL PIPE. THE PIPE MUST NOT BE THREADED AT THE ANTENNA MOUNT END. THE PIPE SHALL BE CUT TO THE REQUIRED LENGTH (MIN. OF 18", 8" IF MOUNTING TO NEW MMBS-BBU) USING A HAND OR ROTARY PIPE CUTTER TO ASSURE A SMOOTH AND PERPENDICULAR CUT. A HACK SAW SHALL NOT BE USED. THE CUT PIPE END SHALL BE DEBURRED.
  - IT IS CRITICAL THAT THE GPS ANTENNA IS MOUNTED SUCH THAT IT IS WITHIN 2 DEGREES OF VERTICAL AND THE BASE OF THE ANTENNA IS WITHIN 2" OF LEVEL.
  - DO NOT SWEEP TEST GPS ANTENNA
  - ATTACH GPS MOUNTING PIPE TO NEW MMBS-BBU USING (4) 8MMx15MM SS BOLTS AND (4) 1" PIPE STRAPS. GPS TO BE MOUNTED A MIN. OF 2'-0" ABOVE MMBS-BBU CABINET.

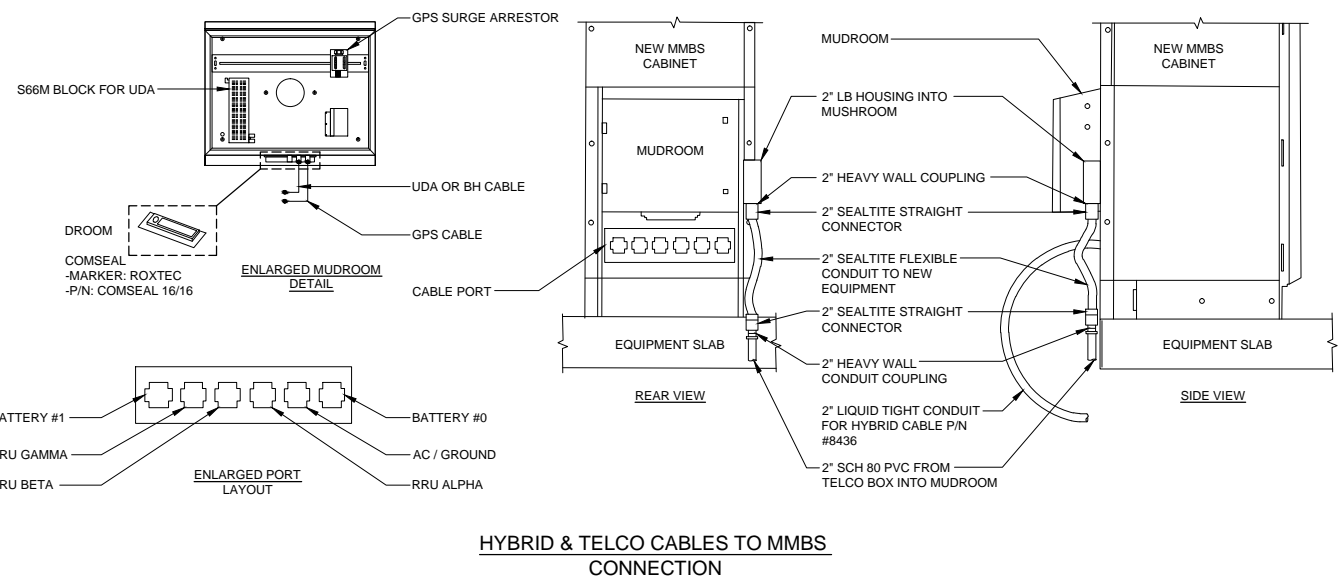

**MMBS CABINET SPECIFICATIONS** SCALE N.T.S. 1

**GPS MOUNTING DETAIL** SCALE N.T.S. 3

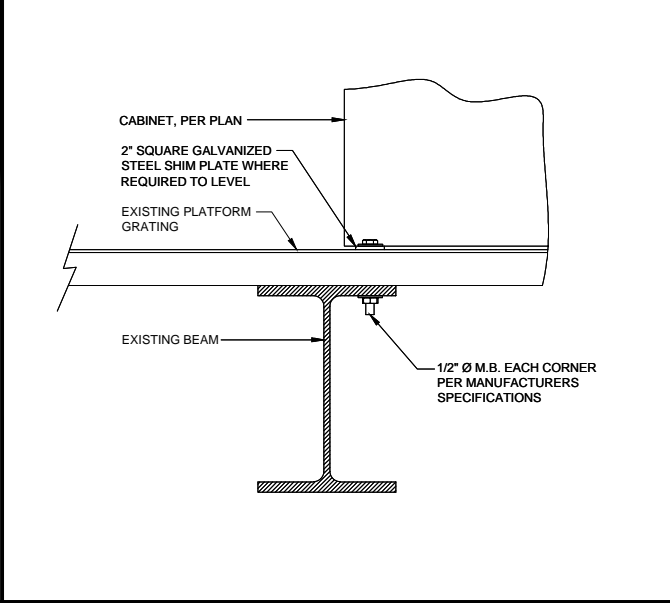
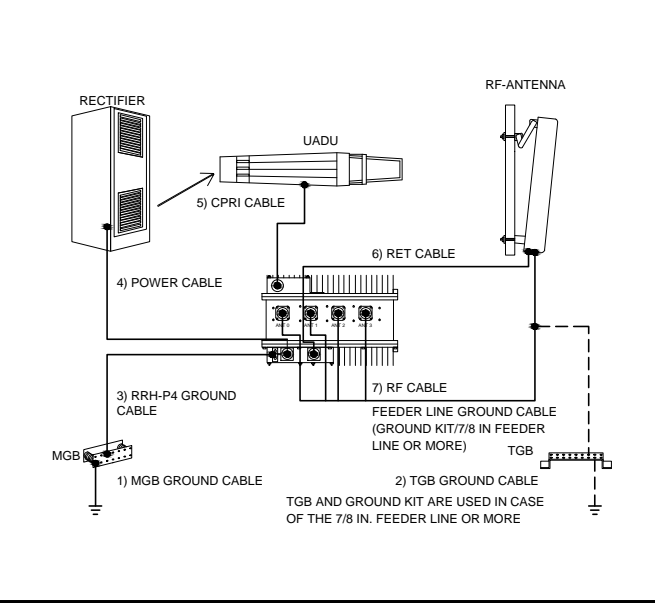

**SAMSUNG MMBS WIRING DIAGRAM** SCALE N.T.S. 4

**CABINET ANCHOR DETAIL** SCALE N.T.S. 5

**NOT USED** SCALE N.T.S. 6

**NOT USED** SCALE N.T.S. 7

**GENERAL DYNAMICS**  
Information Technology

1171 WEST 2400 SOUTH  
WEST VALLEY CITY, UT 84119

**Technology Associates EC Inc.**

**UTAH MARKET OFFICE**  
9847 SOUTH 500 WEST  
SANDY, UTAH 84070  
(801) 463-1020

REV	DATE	DESCRIPTION	BY
C	02/07/2013	ISSUED FOR 90% REVIEW	AC
B	01/21/2013	ISSUED FOR 90% REVIEW	JAA
A	12/03/2012	ISSUED FOR 90% REVIEW	JAA

IT IS A VIOLATION OF LAW FOR ANY PERSON, UNLESS THEY ARE ACTING UNDER THE DIRECTION OF A LICENSED PROFESSIONAL ENGINEER, TO ALTER THIS DOCUMENT.

NETWORK VISION MMBS LAUNCH

**HUNTSVILLE**  
SL54XC068  
750 N. 7200 E.  
HUNTSVILLE, UT 84137

SHEET TITLE  
**DETAILS**

SHEET NUMBER  
**A-7**

NOTE: THE ORIGINAL SIZE OF THIS PLAN IS 24" X 36". SCALE RATIO IS NOT VALID FOR REDUCED OR ENLARGED SHEET SIZES

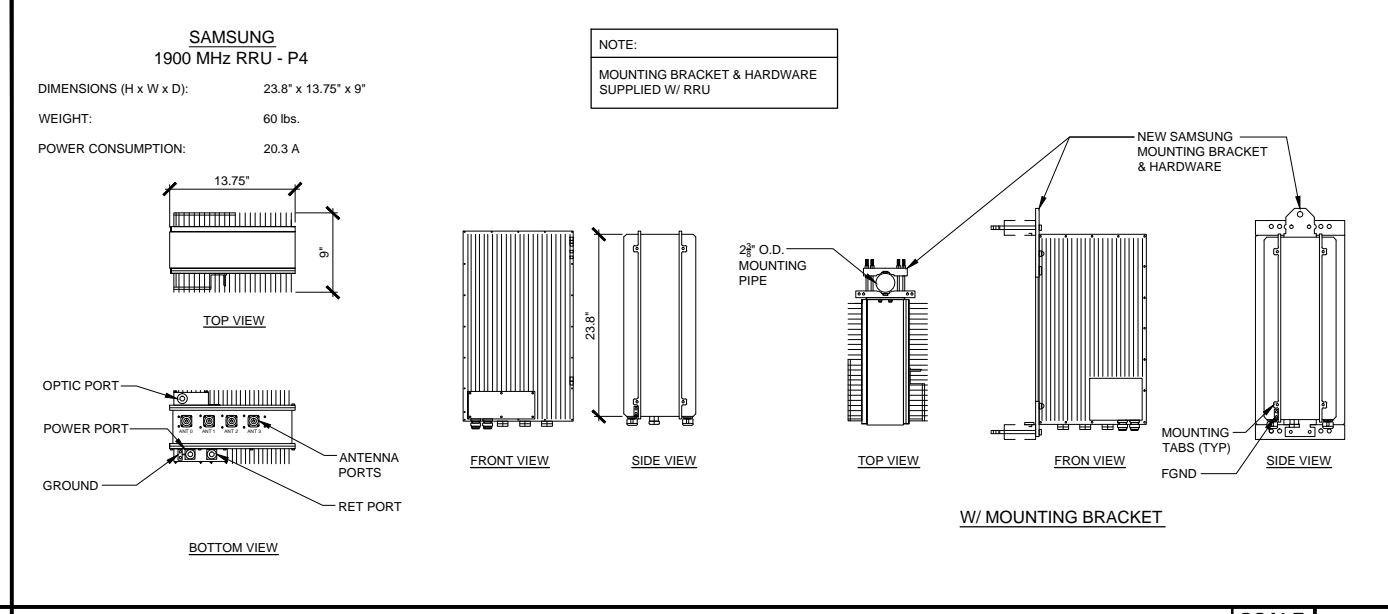
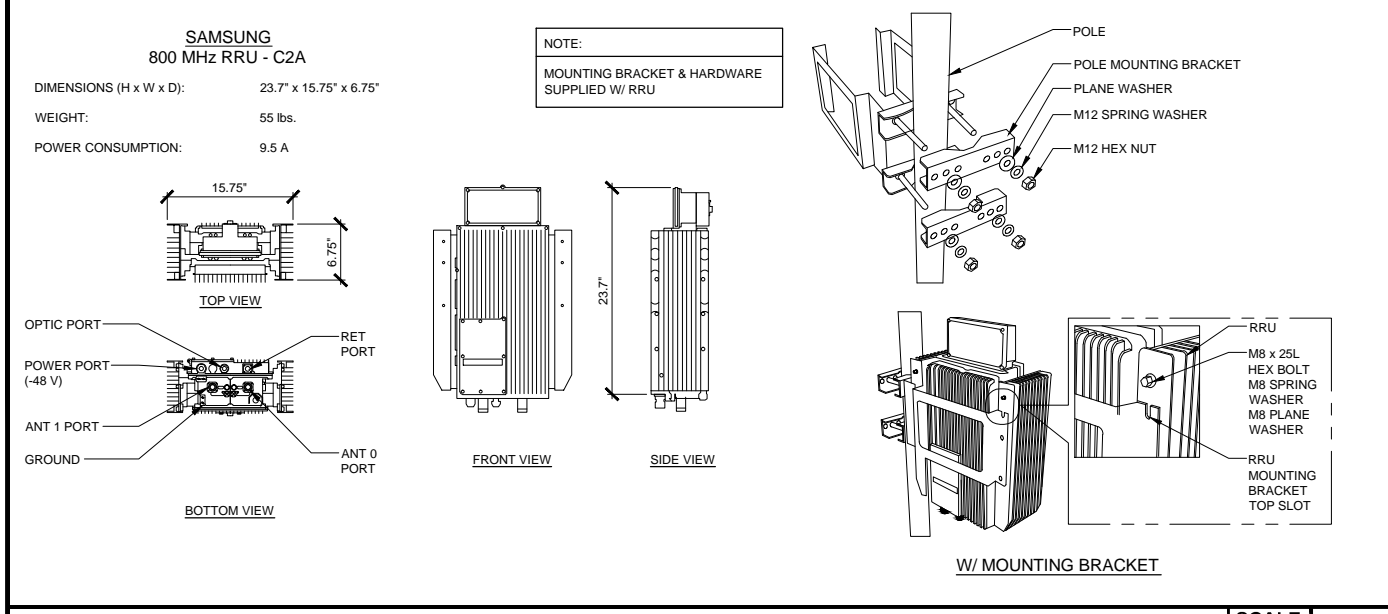

**800MHz RRU SPECIFICATIONS** SCALE N.T.S. 1

**1900MHz RRU SPECIFICATIONS** SCALE N.T.S. 2

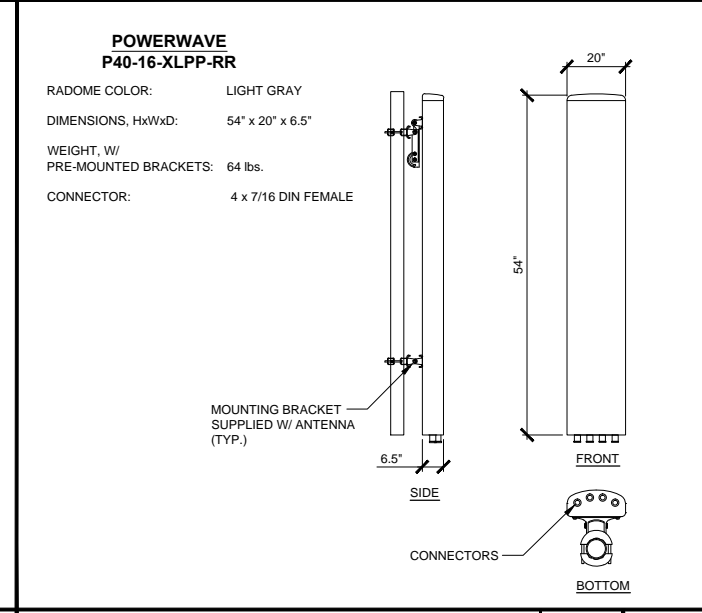
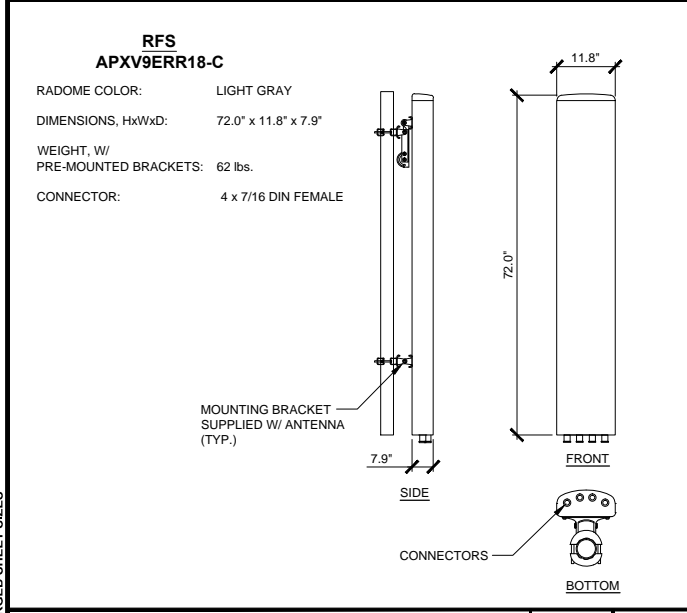

**ANTENNA SPECIFICATIONS** SCALE N.T.S. 3

**ANTENNA SPECIFICATIONS** SCALE N.T.S. 4

**NOT USED** SCALE N.T.S. 5

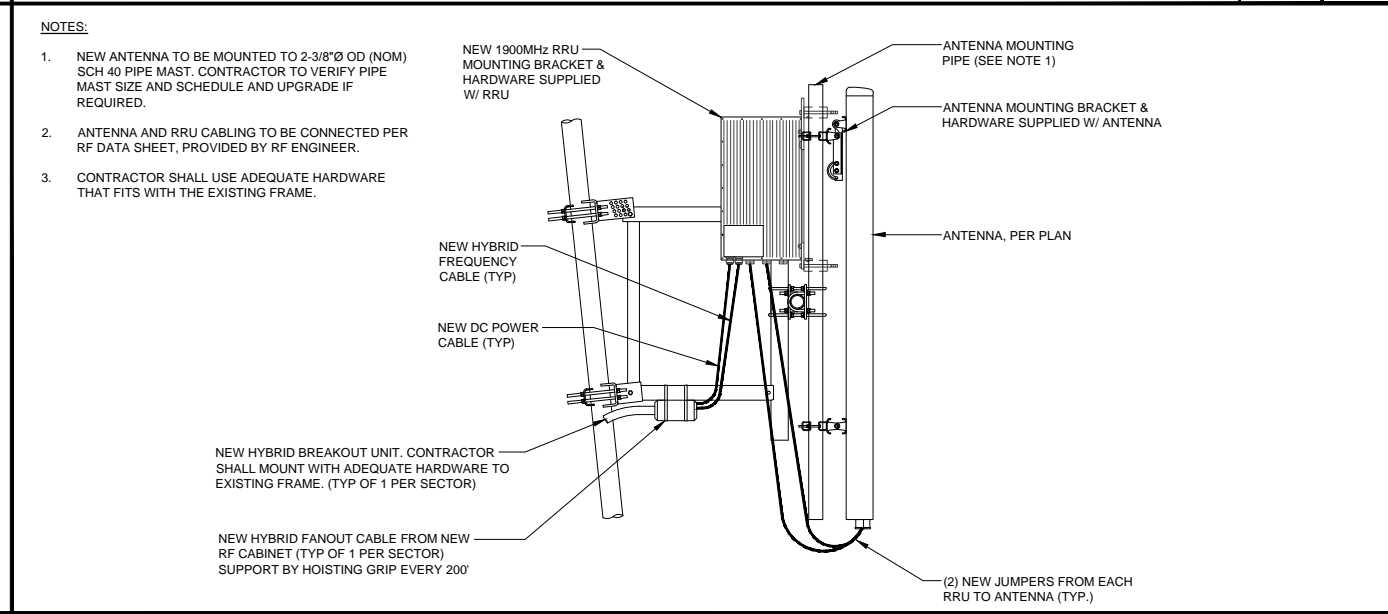
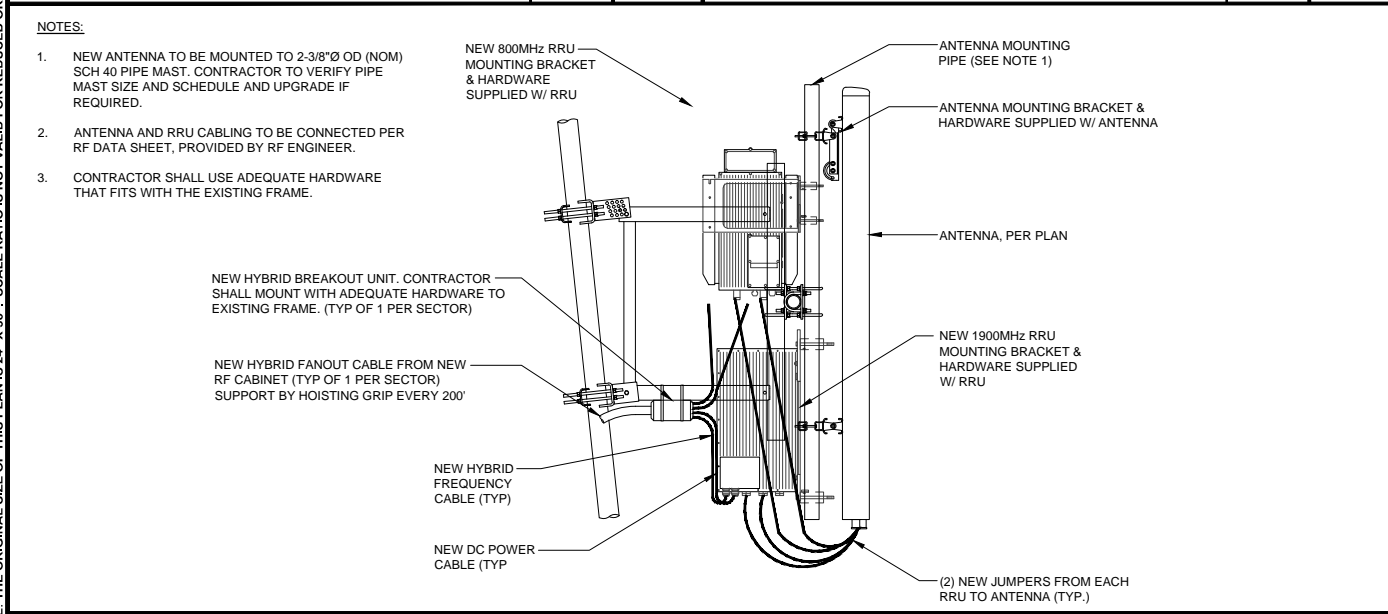

**ANTENNA & RRU MOUNTING** SCALE N.T.S. 6

**ANTENNA & RRU MOUNTING** SCALE N.T.S. 7

**Sprint**

**SAMSUNG**

**GENERAL DYNAMICS**  
Information Technology

1171 WEST 2400 SOUTH  
WEST VALLEY CITY, UT 84119

**Technology Associates**  
EC Inc.

**UTAH MARKET OFFICE**  
9847 SOUTH 500 WEST  
SANDY, UTAH 84070  
(801) 463-1020

REV	DATE	DESCRIPTION	BY
C	02/07/2013	ISSUED FOR 90% REVIEW	AC
B	01/21/2013	ISSUED FOR 90% REVIEW	JAA
A	12/03/2012	ISSUED FOR 90% REVIEW	JAA

IT IS A VIOLATION OF LAW FOR ANY PERSON, UNLESS THEY ARE ACTING UNDER THE DIRECTION OF A LICENSED PROFESSIONAL ENGINEER, TO ALTER THIS DOCUMENT.

NETWORK VISION MMBS LAUNCH

**HUNTSVILLE**  
SL54XC068  
750 N. 7200 E.  
HUNTSVILLE, UT 84137

SHEET TITLE  
**DETAILS**

SHEET NUMBER  
**A-8**

NOTE: THE ORIGINAL SIZE OF THIS PLAN IS 24" x 36". SCALE RATIO IS NOT VALID FOR REDUCED OR ENLARGED SHEET SIZES

**ELECTRICAL NOTES**

- ALL ELECTRICAL WORK SHALL BE DONE IN ACCORDANCE WITH CURRENT NATIONAL ELECTRICAL CODES AND ALL LOCAL AND STATE CODE, LAWS, AND ORDINANCES. PROVIDE ALL COMPONENTS AND WIRING SIZES AS REQUIRED TO MEET NEC STANDARDS.
- CONTRACTOR SHALL COORDINATE WITH LOCAL POWER COMPANY FOR REQUIREMENTS OF POWER SERVICE LINE TO THE METER BASE. WHEN REQUIRED, POWER SERVICE REQUIREMENT IS COMMERCIAL. AC NOMINAL 120/208 VOLT OR 120/240 VOLT, SINGLE PHASE WITH 200 AMP RATING.
- CONTRACTOR SHALL COORDINATE WITH LOCAL TELEPHONE COMPANY FOR SERVICE LINE REQUIREMENTS TO TERMINATE AT THE PPC CABINET.
- CONTRACTOR SHALL FURNISH AND INSTALL ELECTRIC METER BASE AND 200A DISCONNECT SWITCH PER SITE PLAN DETAIL DRAWINGS AND PER LOCAL UTILITY COMPANIES SPECIFICATION, WHEN REQUIRED. THE METER BASE SHOULD BE LOCATED IN A MANNER WHERE ACCESSIBLE BY THE LOCAL POWER COMPANY.
- LOCAL POWER COMPANY SHALL PROVIDE 200 AMP ELECTRIC METER. CONTRACTOR SHALL COORDINATE INSTALLATION OF METER WITH LOCAL POWER COMPANY.
- UNDERGROUND POWER AND TELCO SERVICE LINES SHALL BE ROUTED IN A COMMON TRENCH. ALL UNDERGROUND CONDUIT SHALL BE PVC SCHEDULE 40 AND CONDUIT EXPOSED ABOVE GROUND SHALL BE GALVANIZED RIGID STEEL TUBING UNLESS OTHERWISE INDICATED.
- ALL TELCO CONDUIT LINES SHALL BE 4" SCH. 40 PVC CONDUIT UNLESS OTHERWISE INDICATED. THE TELCO CONDUIT FROM THE PPC SHALL BE ROUTED AND TERMINATED AT DESIGNATED TELCO DEMARCATION OR 2-FEET OUTSIDE FENCED AREA, NEAR UTILITY POLE (IN FENCED AREA), OR END CAP OFF AND PROVIDE MARKER STAKE PAINTED BRIGHT ORANGE WITH DESIGNATION FOR TELCO SERVICE.
- CONDUITS INSTALLED AT PCS EQUIPMENT ENDS PRIOR TO THE EQUIPMENT INSTALLATION SHALL BE STUBBED AND CAPPED AT 6" ABOVE GRADE OR PLATFORM. IF SERVICE LINES CAN'T BE INSTALLED INITIALLY, PROVIDE NYLON PULL CORD IN CONDUITS.
- THE SPRINT CABINET, INCLUDING 200 AMP LOAD PANEL AND TELCO PANEL, SHALL BE PROVIDED BY OWNER AND INSTALLED BY THE CONTRACTOR. CONTRACTOR IS TO INSTALL BREAKER(S) NOT PROVIDED BY MANUFACTURER. SEE PANEL SCHEDULE ON THIS SHEET FOR BREAKER REQUIREMENTS.
- LOCATION OF ELECTRIC METER AND DISCONNECT SWITCH TO BE PROVIDED BY GENERAL CONTRACTOR.
- #2 WIRE TO BE UTILIZED IN ELECTRIC SERVICE RUNS EXCEEDING 100'.
- CONTRACTOR SHALL INSPECT THE EXISTING CONDITIONS PRIOR TO SUBMITTING BID. ANY QUESTIONS ARISING DURING THE BID PERIOD IN REGARDS TO THE CONTRACTORS FUNCTIONS, THE SCOPE OF WORK, OR ANY OTHER ISSUE RELATED TO THIS PROJECT SHALL BE BROUGHT UP DURING THE BID PERIOD WITH THE PROJECT MANAGER FOR CLARIFICATION, NOT AFTER THE CONTRACT HAS BEEN AWARDED.
- LOCATION OF EQUIPMENT, CONDUIT AND DEVICES SHOWN ON THE DRAWINGS ARE APPROXIMATE AND SHALL BE COORDINATED WITH FIELD CONDITIONS PRIOR TO ROUGH-IN.
- THE CONDUIT RUNS AS SHOWN ON THE PLANS ARE APPROXIMATE. EXACT LOCATION AND ROUTING SHALL BE PER EXISTING FIELD CONDITIONS.

- PROVIDE PULL BOXES AND JUNCTION BOXES WHERE SHOWN OR REQUIRED BY NEC.
- ALL CONDUITS SHALL BE MET WITH BENDS MADE IN ACCORDANCE WITH NEC TABLE 346-10. NO RIGHT ANGLE DEVICE OTHER THAN STANDARD CONDUIT ELBOWS WITH 12" MINIMUM INSIDE SWEEPS FOR ALL CONDUITS 2" OR LARGER.
- ALL CONDUIT TERMINATIONS SHALL BE PROVIDED WITH PLASTIC THROAT INSULATING GROUNDING BUSHINGS.
- ALL WIRE SHALL BE "TYPE THWN, SOLID, ANNEALED COPPER UP TO SIZE 1/10 AWG (18 AND LARGER SHALL BE CONCENTRIC STRANDED) 75 DEGREE C, (167 DEGREES F), 98" CONDUCTIVITY, MINIMUM #12.
- ALL WIRES SHALL BE TAGGED AT ALL PULL BOXES, J-BOXES, EQUIPMENT BOXES AND CABINETS WITH APPROVED PLASTIC TAGS, ACTION CRAFT, BRADY, OR APPROVED EQUAL.
- ALL NEW MATERIAL SHALL HAVE A U.L. LABEL.
- CONDUIT ROUGH-IN SHALL BE COORDINATED WITH THE MECHANICAL EQUIPMENT TO AVOID LOCATION TO CONFLICTS. VERIFY WITH MECHANICAL CONTRACTOR AND COMPLY AS REQUIRED.
- ALL PANEL DIRECTORIES SHALL BE TYPEWRITTEN NOT HAND WRITTEN.
- INSTALL AN EQUIPMENT GROUNDING CONDUCTOR IN ALL CONDUITS PER THE SPECIFICATIONS AND NEC. THE EQUIPMENT GROUNDING CONDUCTORS SHALL BE BONDED AT ALL JUNCTION BOXES, PULLBOXES, AND ALL DISCONNECT SWITCHES, STARTERS, AND EQUIPMENT CABINETS.
- THE CONTRACTOR SHALL PREPARE AS-BUILT DRAWINGS. DOCUMENT ANY AND ALL WIRING AND EQUIPMENT CONDITIONS AND CHANGES WHILE COMPLETING THIS CONTRACT. SUBMIT AT SUBSTANTIAL COMPLETION.
- ALL DISCONNECT SWITCHES AND OTHER CONTROLLING DEVICES SHALL BE PROVIDED WITH ENGRAVED PHENOLIC NAMEPLATES INDICATING EQUIPMENT CONTROLLED, BRANCH CIRCUITS INSTALLED ON, AND PANEL FIELD LOCATIONS FED FROM (NO EXCEPTIONS.) PROVIDE SAMPLE FOR CONSTRUCTION MANAGER'S APPROVAL.
- ALL ELECTRICAL DEVICES AND INSTALLATIONS OF THE DEVICES SHALL COMPLY WITH (ADA) AMERICANS WITH DISABILITIES ACT AS ADOPTED BY THE APPLICABLE STATE.
- PROVIDE CORE DRILLING AS NECESSARY FOR PENETRATIONS OR RISERS THROUGH BUILDING. DO NOT PENETRATE STRUCTURAL MEMBERS WITHOUT CONSTRUCTION MANAGERS APPROVAL. SLEEVES AND/OR PENETRATIONS IN FIRE RATED CONSTRUCTION SHALL BE PACKED WITH FIRE RATED MATERIAL WHICH SHALL MAINTAIN THE FIRE RATING OF THE WALL OR STRUCTURE. FILL FOR FLOOR PENETRATIONS SHALL PREVENT PASSAGE OF WATER, SMOKE, FIRE AND FUMES. ALL MATERIAL SHALL BE UL APPROVED FOR THIS PURPOSE.
- ELECTRICAL CHARACTERISTICS OF ALL EQUIPMENT (NEW AND EXISTING) SHALL BE FIELD VERIFIED WITH THE OWNER'S REPRESENTATIVE AND EQUIPMENT SUPPLIER PRIOR TO ROUGH-IN OF CONDUIT AND WIRE. ALL EQUIPMENT SHALL BE PROPERLY CONNECTED ACCORDING TO THE NAMEPLATE DATA FURNISHED ON THE EQUIPMENT (THE DESIGN OF THESE PLANS ARE BASED UPON BEST AVAILABLE INFORMATION AT THE TIME OF DESIGN AND SOME EQUIPMENT CHARACTERISTICS MAY VARY FROM DESIGN AS SHOWN ON THESE DRAWINGS).
- LOCATION OF ALL OUTLET, BOXES, ETC., AND THE TYPE OF CONNECTION (PLUG OR DIRECT) SHALL BE CONFIRMED WITH THE OWNER'S REPRESENTATIVE PRIOR TO ROUGH-IN.

**ELECTRICAL ONE-LINE DIAGRAM**

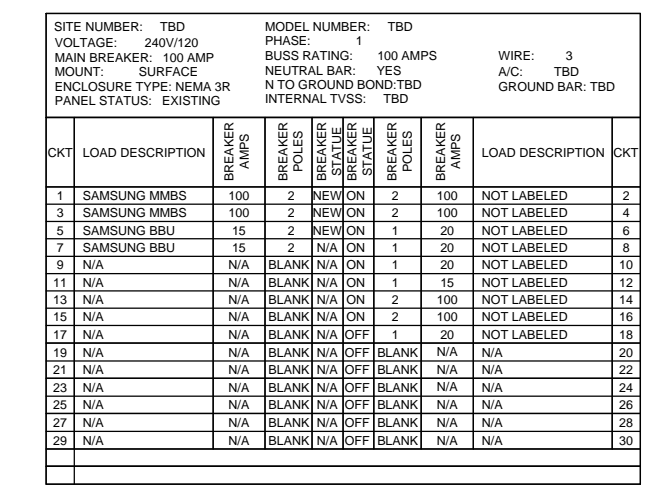

SITE NUMBER: TBD		MODEL NUMBER: TBD	
VOLTAGE: 240V/120		PHASE: 1	
MAIN BREAKER: 100 AMP		BUSS RATING: 100 AMPS	
MOUNT: SURFACE		NEUTRAL BAR: YES	
ENCLOSURE TYPE: NEMA 3R		N TO GROUND BOND: TBD	
PANEL STATUS: EXISTING		INTERNAL TVSS: TBD	
		WIRE: 3	
		A/C: TBD	
		GROUND BAR: TBD	

CKT	LOAD DESCRIPTION	BREAKER AMPS	BREAKER POLES	BREAKER STATUS	BREAKER POLES	BREAKER AMPS	LOAD DESCRIPTION	CKT
1	SAMSUNG MMBS	100	2	NEW	ON	2	100	NOT LABELED
2	SAMSUNG MMBS	100	2	NEW	ON	2	100	NOT LABELED
3	SAMSUNG BBU	15	2	NEW	ON	1	20	NOT LABELED
4	SAMSUNG BBU	15	2	N/A	ON	1	20	NOT LABELED
5	N/A	N/A	BLANK	N/A	ON	1	20	NOT LABELED
6	N/A	N/A	BLANK	N/A	ON	1	15	NOT LABELED
7	N/A	N/A	BLANK	N/A	ON	2	100	NOT LABELED
8	N/A	N/A	BLANK	N/A	ON	2	100	NOT LABELED
9	N/A	N/A	BLANK	N/A	OFF	1	20	NOT LABELED
10	N/A	N/A	BLANK	N/A	OFF	BLANK	N/A	N/A
11	N/A	N/A	BLANK	N/A	OFF	BLANK	N/A	N/A
12	N/A	N/A	BLANK	N/A	OFF	BLANK	N/A	N/A
13	N/A	N/A	BLANK	N/A	OFF	BLANK	N/A	N/A
14	N/A	N/A	BLANK	N/A	OFF	BLANK	N/A	N/A
15	N/A	N/A	BLANK	N/A	OFF	BLANK	N/A	N/A
16	N/A	N/A	BLANK	N/A	OFF	BLANK	N/A	N/A
17	N/A	N/A	BLANK	N/A	OFF	BLANK	N/A	N/A
18	N/A	N/A	BLANK	N/A	OFF	BLANK	N/A	N/A
19	N/A	N/A	BLANK	N/A	OFF	BLANK	N/A	N/A
20	N/A	N/A	BLANK	N/A	OFF	BLANK	N/A	N/A
21	N/A	N/A	BLANK	N/A	OFF	BLANK	N/A	N/A
22	N/A	N/A	BLANK	N/A	OFF	BLANK	N/A	N/A
23	N/A	N/A	BLANK	N/A	OFF	BLANK	N/A	N/A
24	N/A	N/A	BLANK	N/A	OFF	BLANK	N/A	N/A
25	N/A	N/A	BLANK	N/A	OFF	BLANK	N/A	N/A
26	N/A	N/A	BLANK	N/A	OFF	BLANK	N/A	N/A
27	N/A	N/A	BLANK	N/A	OFF	BLANK	N/A	N/A
28	N/A	N/A	BLANK	N/A	OFF	BLANK	N/A	N/A
29	N/A	N/A	BLANK	N/A	OFF	BLANK	N/A	N/A
30	N/A	N/A	BLANK	N/A	OFF	BLANK	N/A	N/A

NOTES:  
 1. CONTRACTOR TO INSTALL NEW 66 BLOCK IN EXISTING HOFFMAN BOX AT SITES MAIN TELCO DEMARC.  
 2. CONTRACTOR SHALL INSTALL RJ-45 ENDS ON ALL (6) RUNS OF CAT5e INTO MMBS-BBU MUDROOM  
 3. CONTRACTOR TO INSTALL NEW 66 BLOCK IN EXISTING TELCO BOX NEXT TO EXISTING PPC CABINET.

**ELECTRICAL NOTES**

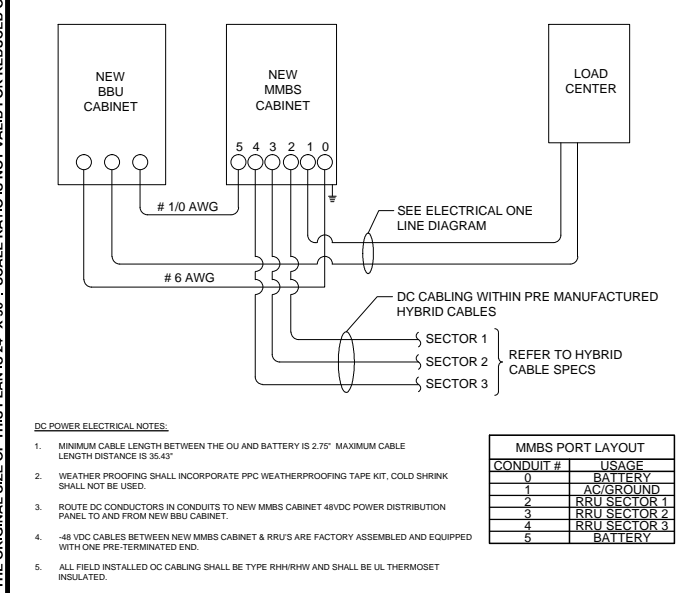

**DC POWER DIAGRAM** SCALE N.T.S. 5

**1 PANEL SCHEDULE**

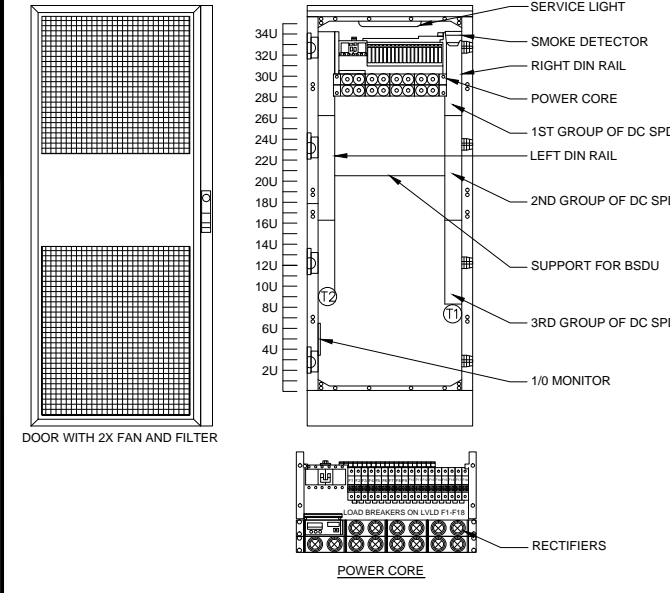

**MMBS-BBU ELECTRICAL** SCALE N.T.S. 6

**3 MUDROOM ELECTRICAL**

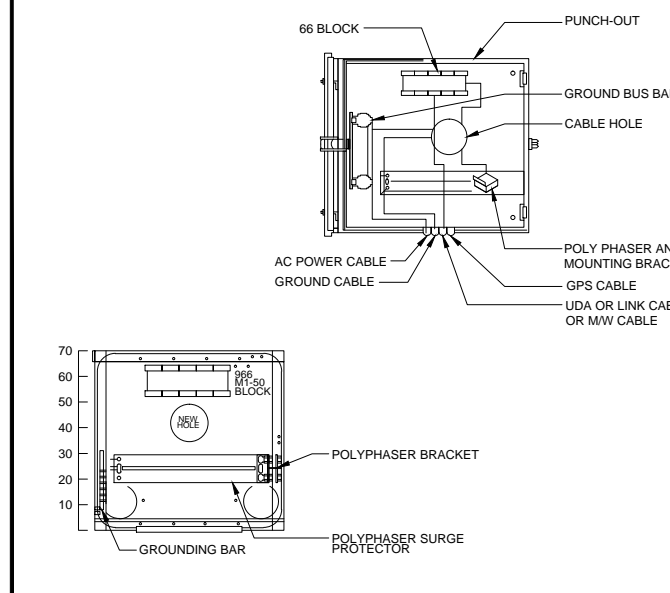

**MUDROOM ELECTRICAL** SCALE N.T.S. 7

**4 TELCO RISER DIAGRAM** SCALE N.T.S. 4

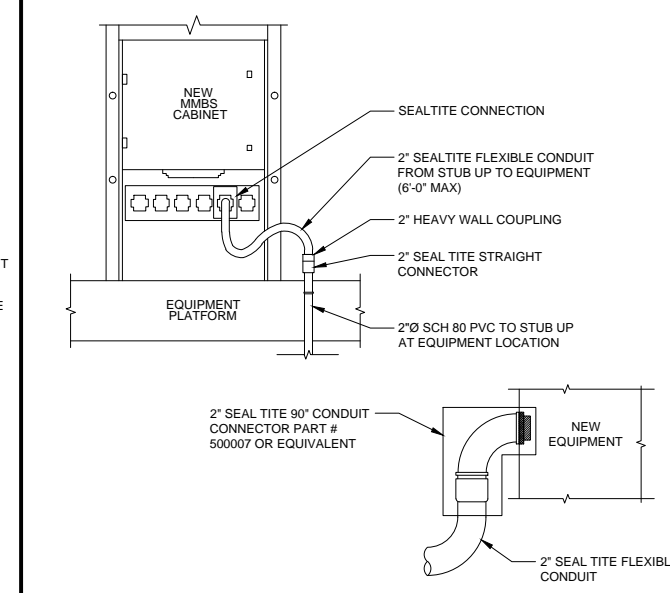

**CONDUIT CONNECTION** SCALE N.T.S. 8

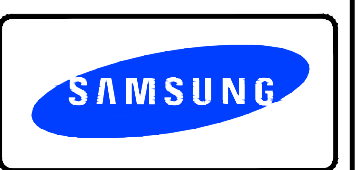

**GENERAL DYNAMICS**  
 Information Technology  
 1171 WEST 2400 SOUTH  
 WEST VALLEY CITY, UT 84119

**Technology Associates EC Inc.**  
**UTAH MARKET OFFICE**  
 9847 SOUTH 500 WEST  
 SANDY, UTAH 84070  
 (801) 463-1020

REV	DATE	DESCRIPTION	BY
C	02/07/2013	ISSUED FOR 90% REVIEW	AC
B	01/21/2013	ISSUED FOR 90% REVIEW	JAA
A	12/03/2012	ISSUED FOR 90% REVIEW	JAA

IT IS A VIOLATION OF LAW FOR ANY PERSON, UNLESS THEY ARE ACTING UNDER THE DIRECTION OF A LICENSED PROFESSIONAL ENGINEER, TO ALTER THIS DOCUMENT.

NETWORK VISION MMBS LAUNCH  
**HUNTSVILLE**  
**SL54XC068**  
 750 N. 7200 E.  
 HUNTSVILLE, UT 84137

SHEET TITLE  
**ONE-LINE DIAGRAM & POWER PANEL SCHEDULE**

SHEET NUMBER  
**E-1**

NOTE: THE ORIGINAL SIZE OF THIS PLAN IS 24" X 36". SCALE RATIO IS NOT VALID FOR REDUCED OR ENLARGED SHEET SIZES

**GENERAL GROUNDING NOTES:**

- ALL DETAILS ARE SHOWN IN GENERAL TERMS. ACTUAL INSTALLATION AND CONSTRUCTION MAY VARY DUE TO SITE SPECIFIC CONDITIONS.
- GROUND ALL ANTENNA BASES, FRAMES, CABLE RUNS, AND OTHER METALLIC COMPONENTS USING GROUND WIRES AND CONNECT TO SURFACE MOUNTED BUS BARS. FOLLOW ANTENNA AND BTS MANUFACTURERS PRACTICES FOR GROUNDING REQUIREMENTS. GROUND COAX SHIELD AT BOTH ENDS AND EXIT FROM TOWER OR POLE USING MFR'S PRACTICES.
- ALL GROUND CONNECTIONS SHALL BE EXOTHERMIC. ALL WIRES SHALL BE COPPER THHN/THWN. ALL GROUND WIRE SHALL BE GREEN INSULATED WIRE ABOVE GROUND.
- CONTRACTOR TO VERIFY AND TEST GROUND TO SOURCE. GROUNDING AND OTHER OPERATIONAL TESTING WILL BE WITNESSED BY SPRINT REPRESENTATIVE.
- REFER TO DIVISION 16 GENERAL ELECTRIC; GENERAL ELECTRICAL PROVISION AND COMPLY WITH ALL REQUIREMENTS OF GROUNDING STANDARDS.
- ELECTRICAL CONTRACTOR TO PROVIDE DETAILED DESIGN OF GROUNDING SYSTEM PER SPRINT STANDARD GROUNDING METHOD, AND RECEIVE APPROVAL OF DESIGN BY AUTHORIZED SPRINT REPRESENTATIVE, PRIOR TO INSTALLATION OF GROUNDING SYSTEM. PHOTO DOCUMENT ALL EXOTHERMIC AND GROUND RING.
- NOTIFY CONSTRUCTION MANAGER IF THERE ARE ANY DIFFICULTIES INSTALLING GROUNDING SYSTEM DUE TO SITE SOIL CONDITIONS.
- ALL EXISTING GROUND BARS, WIRES & CONNECTIONS SHALL BE FIELD VERIFIED. ANY DEFICIENT ITEMS SHALL BE REPLACED AS REQUIRED TO ACHIEVE ADEQUATE GROUNDING REQUIRED BY SPRINT.

**GROUNDING NOTES:**

- EXOTHERMIC WELDS (2) 2 AWG BARE TINNED SOLID COPPER CONDUCTORS TO GROUNDING BAR. ROUTE CONDUCTORS TO BURIED GROUNDING RING AND PROVIDE PARALLEL EXOTHERMIC WELD.
- G.C. SHALL USE PERMANENT MARKER TO DRAW THE LINES BETWEEN EACH SECTION AND LABEL EACH SECTION ("P", "A", "N", "Y") WITH 1" HIGH LETTERS.
- ALL HARDWARE 18-8 STAINLESS STEEL, INCLUDING LOCK WASHERS, COAT ALL SURFACES WITH AN ANTI-OXIDANT COMPOUND BEFORE MATING. ALL HARDWARE SHALL BE STAINLESS STEEL 3/8 INCH DIAMETER OR LARGER.
- FOR GROUND BOND TO STEEL ONLY: INSERT A CADMIUM FLAT WASHER BETWEEN LUG AND STEEL, COAT ALL SURFACES WITH AN ANTI-OXIDANT COMPOUND BEFORE MATING.
- NUT & WASHER SHALL BE PLACED ON THE FRONT SIDE OF THE GROUNDING BAR AND BOLTED ON THE BACK SIDE. INSTALL BLACK HEAT-SHRINKING TUBE, 600 VOLT INSULATION ON ALL GROUNDING TERMINATIONS. THE INTENT IS TO WEATHERPROOF THE COMPRESSION CONNECTION.
- NUMBER OF GROUNDING BARS MAY VARY DEPENDING ON THE TYPE OF TOWER, ANTENNA LOCATION, AND CONNECTION ORIENTATION. PROVIDE AS REQUIRED.
- GROUNDING KIT SHALL BE TYPE AND PART NUMBER AS SUPPLIED OR RECOMMENDED BY CABLE MANUFACTURER.
- WEATHERPROOFING SHALL BE TYPE AND PART NUMBER AS SUPPLIED OR RECOMMENDED BY CABLE MANUFACTURER.
- WEATHERPROOFING SHALL BE SUPPLIED AND INSTALLED BY CONTRACTOR.
- WHEN THE SCOPE OF WORK REQUIRES THE ADDITION OF A GROUNDING BAR TO AN EXISTING TOWER, THE SUBCONTRACTOR SHALL OBTAIN APPROVAL FROM THE TOWER OWNER PRIOR TO MOUNTING THE GROUNDING BAR TO THE TOWER.
- EXTEND TWO (2) 2 AWG TINNED CU CONDUCTOR FROM BURIED GROUNDING RING AND CONNECT TO THE PROPOSED TOWER. FOLLOW MANUFACTURERS RECOMMENDATIONS FOR GROUNDING CONNECTIONS TO THE TOWER. (APPLICABLE TO NEW TOWERS ONLY.)
- NUMBER OF GROUNDING BARS MAY VARY DEPENDING ON THE TYPE OF TOWER, ANTENNA LOCATION, AND CONNECTION ORIENTATION. THE SUBCONTRACTOR SHALL BE RESPONSIBLE FOR INSTALLING ADDITIONAL GROUNDING BARS AS REQUIRED, PROVIDING 50% SPARE CONNECTION POINTS.
- EXPOSED GROUND WIRES TO BE NON METALLIC LIQUID TIGHT.

LEGEND	
	EXOTHERMIC CONNECTION
	MECHANICAL CONNECTION
	EQUIPMENT GROUND BAR
	ANTENNA GROUND BAR (AS REQUIRED)
	#2 AWG GROUND LEAD (AS REQUIRED)

**NOTE:**

- CONTRACTOR TO REPLACE ALL MISSING GROUND BARS AND GROUNDING CONNECTIONS AS REQUIRED.

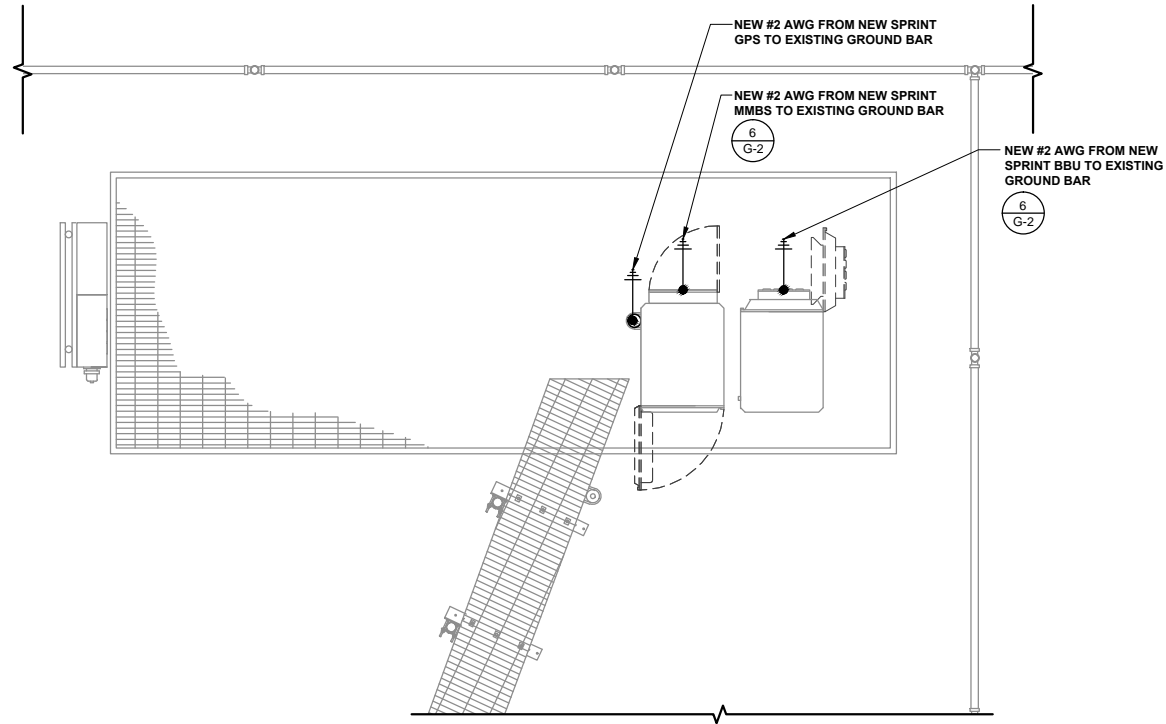

**EQUIPMENT GROUNDING (FINAL)**

SCALE N.T.S. 2

REV	DATE	DESCRIPTION	BY
C	02/07/2013	ISSUED FOR 90% REVIEW	AC
B	01/21/2013	ISSUED FOR 90% REVIEW	JAA
A	12/03/2012	ISSUED FOR 90% REVIEW	JAA

IT IS A VIOLATION OF LAW FOR ANY PERSON, UNLESS THEY ARE ACTING UNDER THE DIRECTION OF A LICENSED PROFESSIONAL ENGINEER, TO ALTER THIS DOCUMENT.

NETWORK VISION MMBS LAUNCH  
**HUNTSVILLE**  
 SL54XC068  
 750 N. 7200 E.  
 HUNTSVILLE, UT 84137

SHEET TITLE  
**GROUNDING PLAN**

SHEET NUMBER  
**G-1**

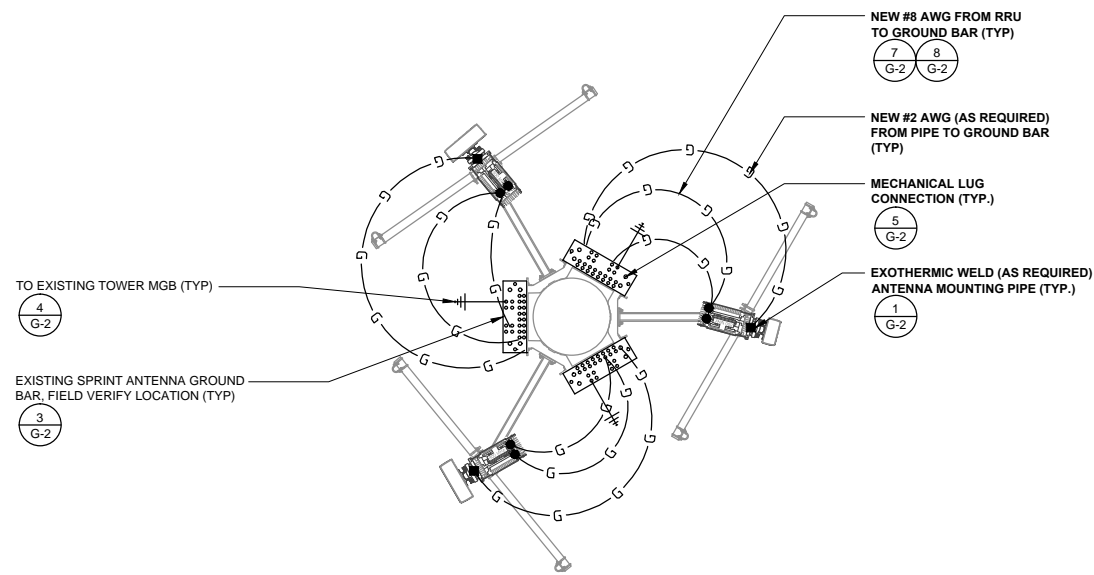

**NOTE:**

- CONTRACTOR TO REPLACE ALL MISSING GROUND BARS AND GROUNDING CONNECTIONS AS REQUIRED.



**NOTES & LEGEND**

1

**ANTENNA GROUNDING (FINAL)**

SCALE N.T.S. 3

NOTE: THE ORIGINAL SIZE OF THIS PLAN IS 24" X 36". SCALE RATIO IS NOT VALID FOR REDUCED OR ENLARGED SHEET SIZES.

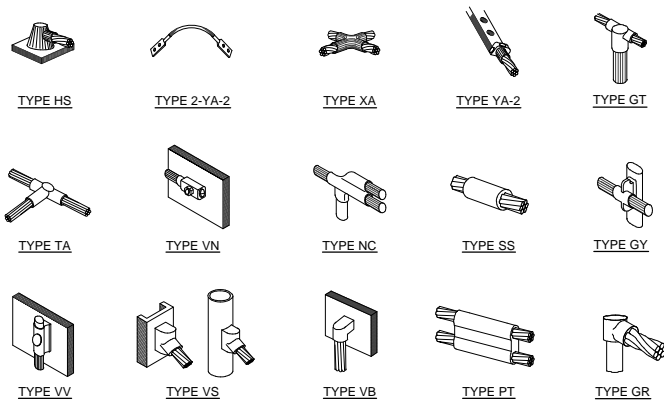

**NOTE:**  
 ERICO EXOTHERMIC "MOLD TYPES" SHOWN HERE ARE EXAMPLES. CONSULT WITH PROJECT MANAGER FOR SPECIFIC MOLDS TO BE USED FOR THIS PROJECT.

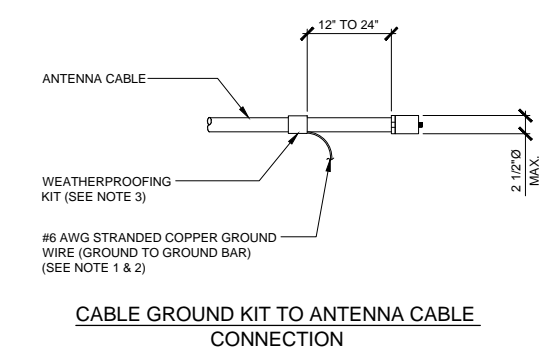
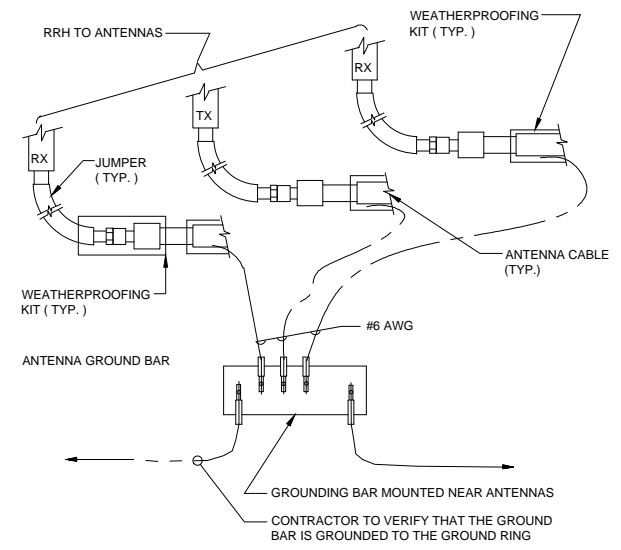

- NOTES:**
- DO NOT INSTALL CABLE GROUND KIT AT A BEND AND ALWAYS DIRECT GROUND WIRE DOWN TO GROUND BAR.
  - GROUNDING KIT SHALL BE WITH TWO-HOLE LUG.
  - WEATHERPROOFING SHALL INCORPORATE PPC WEATHERPROOFING TAPE KIT, COLD SHRINK SHALL NOT BE USED.

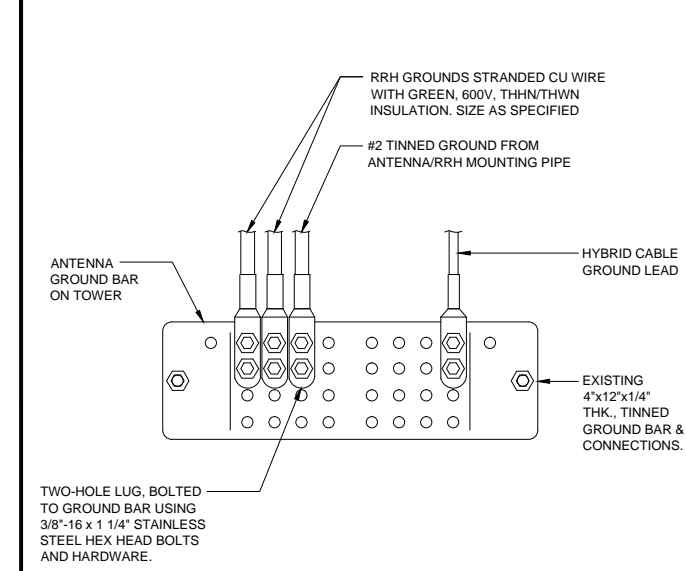

**EXOTHERMIC WELDING**

SCALE  
N.T.S. 1

**CABLE GROUNDING**

SCALE  
N.T.S. 2

**SECTOR GROUND BAR**

SCALE  
N.T.S. 3

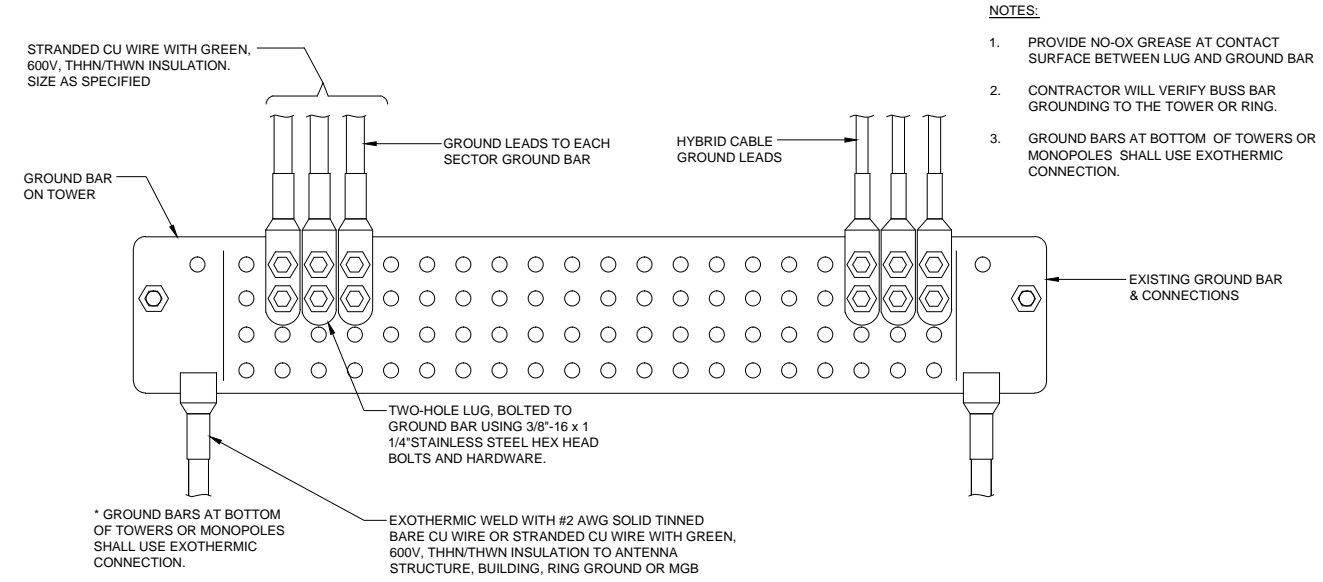

- NOTES:**
- PROVIDE NO-OX GREASE AT CONTACT SURFACE BETWEEN LUG AND GROUND BAR.
  - CONTRACTOR WILL VERIFY BUSS BAR GROUNDING TO THE TOWER OR RING.
  - GROUND BARS AT BOTTOM OF TOWERS OR MONOPOLES SHALL USE EXOTHERMIC CONNECTION.

WIRE SIZE	BURNDY LUG	BOLT SIZE
#6 AWG GREEN INSULATED	YA6C-2TC38	3/8" - 16 NC S 2 BOLT
#2 AWG SOLID TINNED	YA3C-2TC38	3/8" - 16 NC S 2 BOLT
#2 AWG STRANDED	YA2C-2TC38	3/8" - 16 NC S 2 BOLT
#2/0 AWG STRANDED	YA26-2TC38	3/8" - 16 NC S 2 BOLT
#4/0 AWG STRANDED	YA28-2N	1/2" - 16 NC S 2 BOLT

- NOTES:**
- ALL HARDWARE BOLTS, NUTS, LOCK WASHERS SHALL BE STAINLESS STEEL. ALL HARDWARE ARE TO BE AS FOLLOWS: BOLT, FLAT WASHER, GROUND BAR, GROUND LUG, FLAT WASHER AND NUT.
  - COPPER SHIELD, ANTI-OX, CR NO-OX OR EQUIVALENT SHALL BE PLACE WHERE ALL DISSIMILAR METALS CONNECT.
  - ALL LUGS ARE TO BE INSTALLED PER MANUFACTURER'S SPECIFICATIONS.

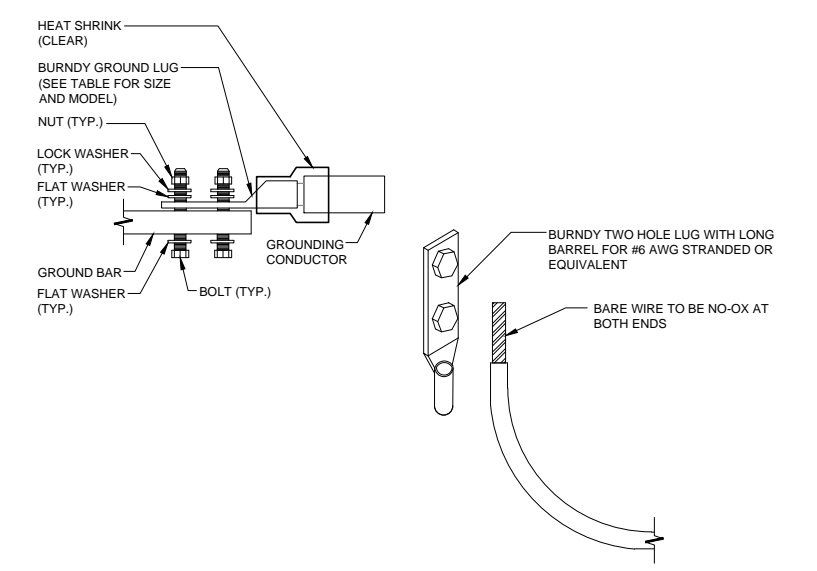

**TOWER MASTER GROUND BAR**

SCALE  
N.T.S. 4

**MECHANICAL LUG CONNECTION**

SCALE  
N.T.S. 5

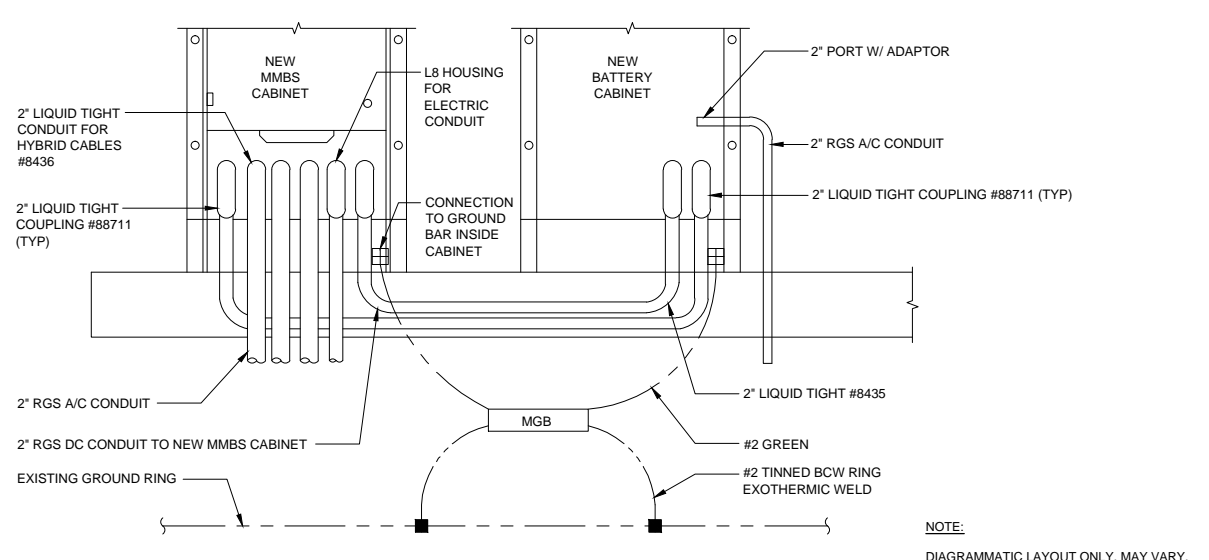

**NOTE:**  
 DIAGRAMATIC LAYOUT ONLY. MAY VARY.

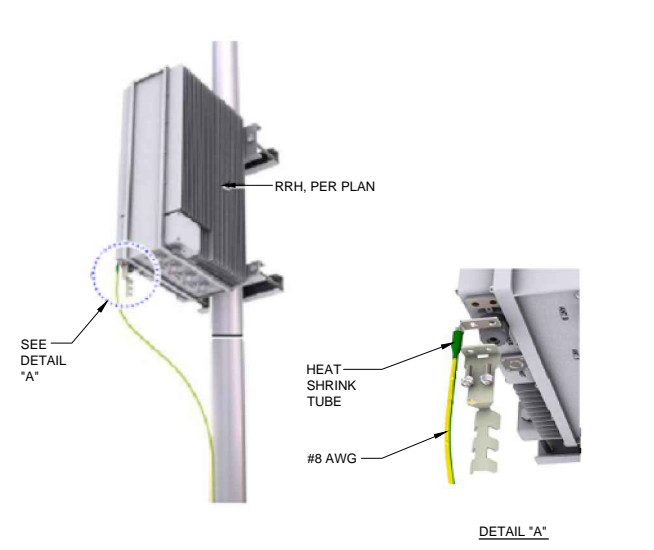
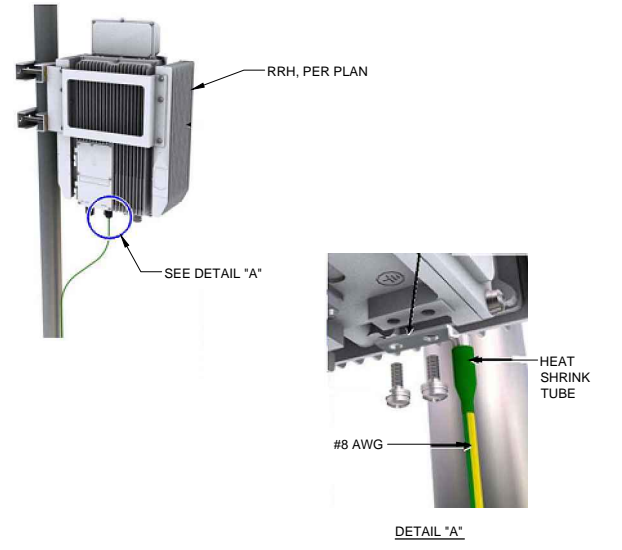

**CABINET GROUNDING**

SCALE  
N.T.S. 6

**800MHz RRH GROUNDING**

SCALE  
N.T.S. 7

**1900MHz RRH GROUNDING**

SCALE  
N.T.S. 8



**GENERAL DYNAMICS**  
 Information Technology

1171 WEST 2400 SOUTH  
 WEST VALLEY CITY, UT 84119

**Technology Associates  
 EC Inc.**

**UTAH MARKET OFFICE**  
 9847 SOUTH 500 WEST  
 SANDY, UTAH 84070  
 (801) 463-1020

REV	DATE	DESCRIPTION	BY
C	02/07/2013	ISSUED FOR 90% REVIEW	AC
B	01/21/2013	ISSUED FOR 90% REVIEW	JAA
A	12/03/2012	ISSUED FOR 90% REVIEW	JAA

IT IS A VIOLATION OF LAW FOR ANY PERSON, UNLESS THEY ARE ACTING UNDER THE DIRECTION OF A LICENSED PROFESSIONAL ENGINEER, TO ALTER THIS DOCUMENT.

NETWORK VISION MMBS LAUNCH  
**HUNTSVILLE**  
**SL54XC068**  
 750 N. 7200 E.  
 HUNTSVILLE, UT 84137

SHEET TITLE  
**GROUNDING  
 DETAILS**

SHEET NUMBER  
**G-2**

NOTE: THE ORIGINAL SIZE OF THIS PLAN IS 24" X 36". SCALE RATIO IS NOT VALID FOR REDUCED OR ENLARGED SHEET SIZES.

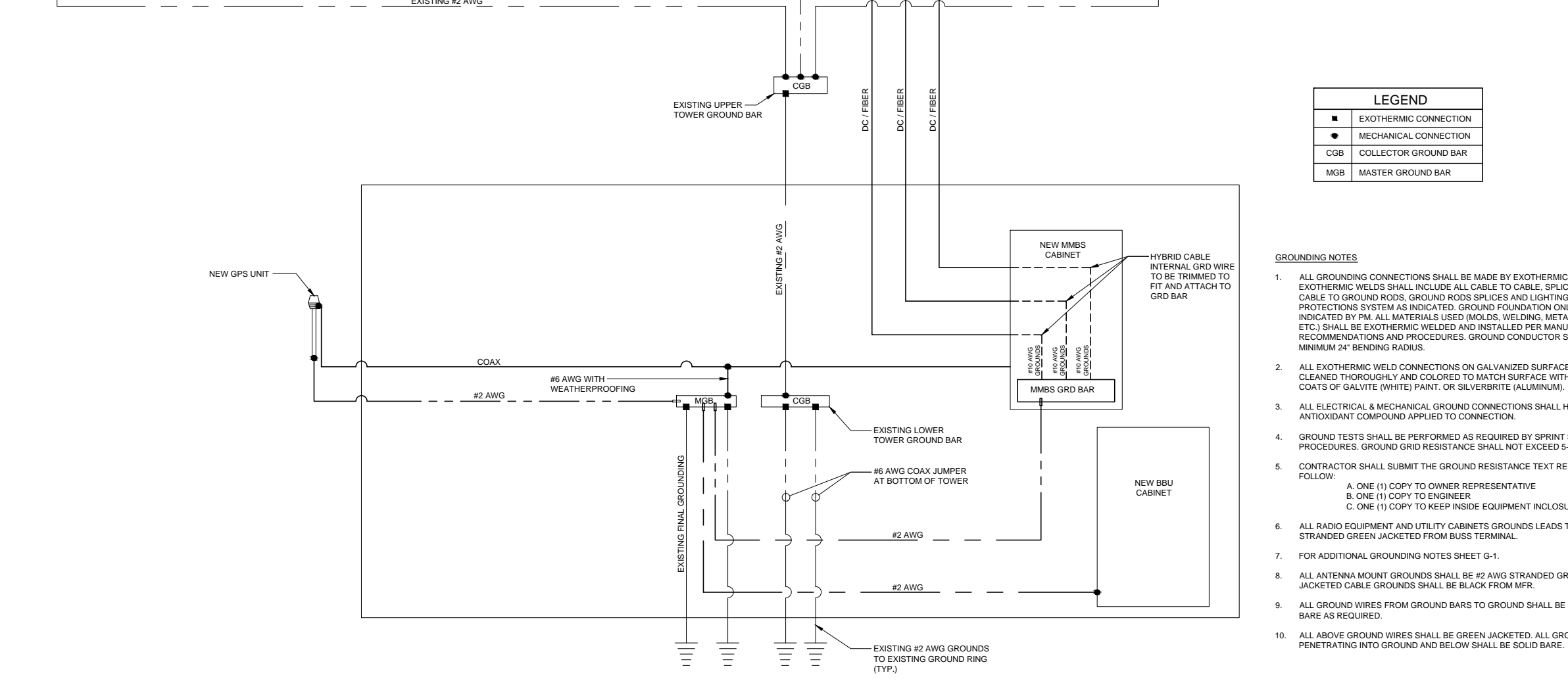
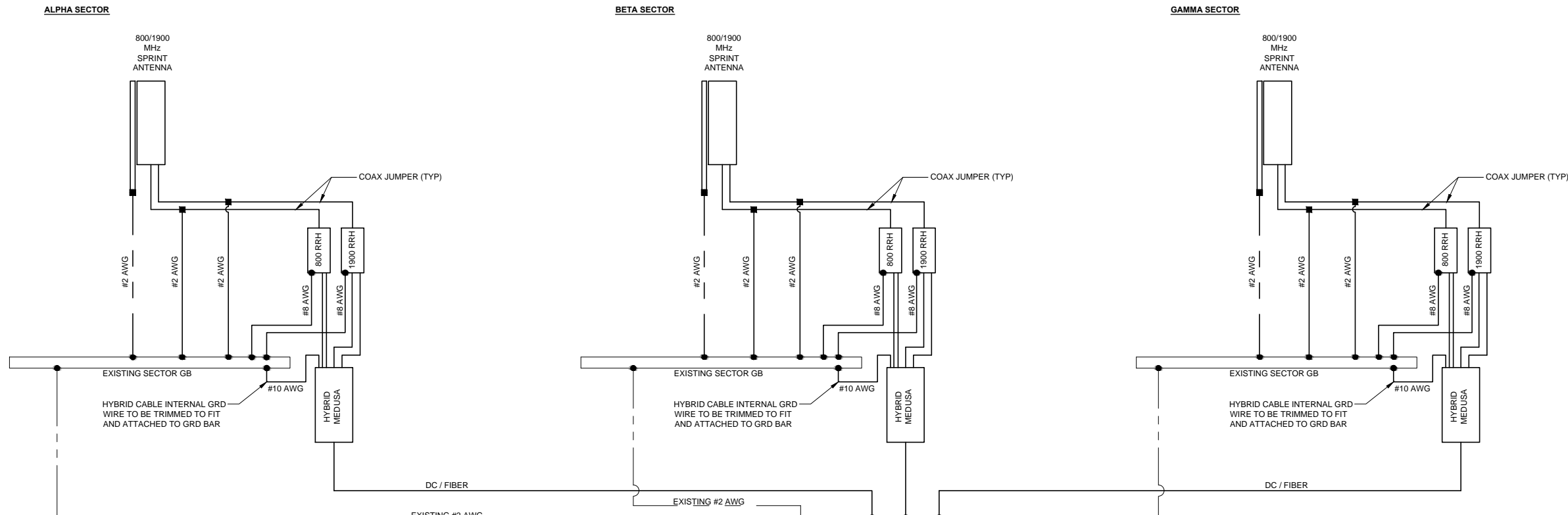

LEGEND	
■	EXOTHERMIC CONNECTION
●	MECHANICAL CONNECTION
CGB	COLLECTOR GROUND BAR
MGB	MASTER GROUND BAR

**GROUNDING NOTES**

- ALL GROUNDING CONNECTIONS SHALL BE MADE BY EXOTHERMIC WELDS. EXOTHERMIC WELDS SHALL INCLUDE ALL CABLE TO CABLE, SPLICES, ETC. ALL CABLE TO GROUND RODS, GROUND RODS SPLICES AND LIGHTING PROTECTIONS SYSTEM AS INDICATED. GROUND FOUNDATION ONLY AS INDICATED BY PM. ALL MATERIALS USED (MOLDS, WELDING, METAL, TOOLS, ETC.) SHALL BE EXOTHERMIC WELDED AND INSTALLED PER MANUFACTURERS RECOMMENDATIONS AND PROCEDURES. GROUND CONDUCTOR SHALL HAVE A MINIMUM 24" BENDING RADIUS.
- ALL EXOTHERMIC WELD CONNECTIONS ON GALVANIZED SURFACES SHALL BE CLEANED THOROUGHLY AND COLORED TO MATCH SURFACE WITH (2) TWO COATS OF GALVITE (WHITE) PAINT, OR SILVERBRITE (ALUMINUM).
- ALL ELECTRICAL & MECHANICAL GROUND CONNECTIONS SHALL HAVE ANTIOXIDANT COMPOUND APPLIED TO CONNECTION.
- GROUND TESTS SHALL BE PERFORMED AS REQUIRED BY SPRINT STANDARD PROCEDURES. GROUND GRID RESISTANCE SHALL NOT EXCEED 5-OHMS.
- CONTRACTOR SHALL SUBMIT THE GROUND RESISTANCE TEXT REPORT AS FOLLOW:
  - ONE (1) COPY TO OWNER REPRESENTATIVE
  - ONE (1) COPY TO ENGINEER
  - ONE (1) COPY TO KEEP INSIDE EQUIPMENT INCLOSURE
- ALL RADIO EQUIPMENT AND UTILITY CABINETS GROUNDS LEADS TO BE #2 AWG STRANDED GREEN JACKETED FROM BUSS TERMINAL.
- FOR ADDITIONAL GROUNDING NOTES SHEET G-1.
- ALL ANTENNA MOUNT GROUNDS SHALL BE #2 AWG STRANDED GREEN JACKETED CABLE GROUNDS SHALL BE BLACK FROM MFR.
- ALL GROUND WIRES FROM GROUND BARS TO GROUND SHALL BE #2 AWG SOLID BARE AS REQUIRED.
- ALL ABOVE GROUND WIRES SHALL BE GREEN JACKETED. ALL GROUND WIRE'S PENETRATING INTO GROUND AND BELOW SHALL BE SOLID BARE.



**GENERAL DYNAMICS**  
Information Technology

1171 WEST 2400 SOUTH  
WEST VALLEY CITY, UT 84119

**Technology Associates**  
**EC Inc.**

**UTAH MARKET OFFICE**  
9847 SOUTH 500 WEST  
SANDY, UTAH 84070  
(801) 463-1020

REV	DATE	DESCRIPTION	BY
C	02/07/2013	ISSUED FOR 90% REVIEW	AC
B	01/21/2013	ISSUED FOR 90% REVIEW	JAA
A	12/03/2012	ISSUED FOR 90% REVIEW	JAA

IT IS A VIOLATION OF LAW FOR ANY PERSON, UNLESS THEY ARE ACTING UNDER THE DIRECTION OF A LICENSED PROFESSIONAL ENGINEER, TO ALTER THIS DOCUMENT.

NETWORK VISION MMBS LAUNCH

**HUNTSVILLE**  
**SL54XC068**  
750 N. 7200 E.  
HUNTSVILLE, UT 84137

SHEET TITLE  
**GROUNDING**  
**DIAGRAM**

SHEET NUMBER  
**G-3**

NOTE: THE ORIGINAL SIZE OF THIS PLAN IS 24" X 36". SCALE RATIO IS NOT VALID FOR REDUCED OR ENLARGED SHEET SIZES



TYPICAL HYBRID CABLE COLOR CODE			
SECTOR	FIRST RING	SECOND RING	THIRD RING
A	GREEN	NO TAPE	NO TAPE
B	GREEN	GREEN	NO TAPE
G	GREEN	GREEN	GREEN

FREQUENCY COLOR CODE FOR PAIRS AND FIBER CABLES OF HYBRID CABLE		
FREQUENCY COLOR CODE	FIRST RING	SECOND RING
800 MHz	YELLOW	GREEN
1900 MHz	YELLOW	RED

TYPICAL JUMPER CABLE COLOR CODE			
TYPE	PORT	COLOR CODE	FREQ. CODE
RRH-C2(800M) RRH-C2A(800M)	PORT#A	GREEN	YELLOW/GREEN
	PORT#B	BLUE	YELLOW/GREEN
	POWER	GREEN	YELLOW/GREEN
	RET	NO CODING	NO CODING
RRH-P4(1.9G)	PORT#0	GREEN	YELLOW/RED
	PORT#1	BLUE	YELLOW/RED
	PORT#2	BROWN	YELLOW/RED
	PORT#3	WHITE	YELLOW/RED
	RET	NO CODING	NO CODING
	POWER	GREEN	YELLOW/RED

COLOR CODE TABLE

SUPPLIER	SAMSUNG FIBEROPTICS				ASIA TAI				
	LENGTH (FT)	TOTAL WEIGHT (KG)	TOTAL WEIGHT (LBS)	WEIGHT/LF (KG)	WEIGHT/LF (LBS)	TOTAL WEIGHT (KG)	TOTAL WEIGHT (LBS)	WEIGHT/LF (KG)	WEIGHT/LF (LBS)
TYPE 1	80	13	28	0.2	0.5	19	41	0.3	0.7
	75	16	35	0.2	0.5	22	49	0.3	0.7
	90	19	42	0.2	0.5	26	57	0.3	0.7
	105	30	66	0.3	0.6	29	65	0.3	0.7
	120	34	75	0.3	0.6	33	73	0.3	0.7
TYPE 2	135	38	85	0.3	0.6	46	101	0.3	0.7
	150	43	94	0.3	0.6	51	112	0.3	0.7
	165	47	104	0.3	0.6	55	122	0.3	0.7
	180	69	151	0.4	0.8	72	160	0.3	0.7
	195	75	164	0.4	0.8	78	173	0.3	0.7
TYPE 3	210	80	177	0.4	0.8	85	187	0.3	0.7
	225	89	196	0.4	0.9	102	224	0.3	0.7
TYPE 4	240	95	209	0.4	0.9	109	239	0.3	0.7
	255	101	222	0.4	0.9	115	254	0.3	0.7
	270	133	293	0.5	1.1	122	270	0.3	0.7
TYPE 5	285	141	310	0.5	1.1	152	335	0.3	0.7
	300	148	326	0.5	1.1	160	353	0.3	0.7
	315	155	342	0.5	1.1	168	371	0.3	0.7
	330	163	359	0.5	1.1	176	388	0.3	0.7

	TYPE 1	TYPE 2	TYPE 3	TYPE 4	TYPE 5	TYPE 6	TYPE 7
TOTAL LENGTH	-114'-9.95"	-180'-5.35"	-213'-3.05"	-262'-5.60"	-328'-1"	-420'-0"	-550'-0"
HYBRID POWER CABLE CONFIGURATION	AWG 10 1 PAIR, AWG 12 3 PAIR	AWG 8 1 PAIR, AWG 10 3 PAIR	AWG 6 1 PAIR, AWG 8 1 PAIR, AWG 10 2 PAIR	AWG 6 1 PAIR, AWG 8 3 PAIR	AWG 4 1 PAIR, AWG 6 1 PAIR, AWG 8 2 PAIR	AWG 4 1 PAIR, AWG 6 3 PAIR	AWG 2 1 PAIR, AWG 4 3 PAIR
CABLE DIAMETER	0.98"	1.06"	1.18"	1.18"/1.25"	1.25"	1.56"	1.69"
BENDING RADIUS	11.81"	12.99"	15.35"	17.71"	17.71"	18.00"/30.00"	21.00"/35.00"
OPTIC CABLE	LC/PC-to-LC/PC, SINGLE MODE						
DU CABINET (POWER CABLE TERMINAL MAX SIZE AWG 4)	2 PAIR POWER AND OPTIC CABLE WITH PE PIPE						
RRU POWER CABLE SPEC	AWG 8, 0.57"-0.60" AWG 10, 0.45"-0.48"					8 AWG CABLES 4 PAIRS	
NON USE POWER AND OPTIC CABLE PROTECTION	2 PAIR POWER AND OPTIC CABLE WITH PE PIPE	2 PAIR POWER AND OPTIC CABLE WITH PE PIPE	2 PAIR POWER AND OPTIC CABLE WITH PE PIPE	2 PAIR POWER AND OPTIC CABLE WITH PE PIPE	2 PAIR POWER AND OPTIC CABLE WITH PE PIPE	2 PAIR POWER AND OPTIC CABLE WITH PE PIPE	2 PAIR POWER AND OPTIC CABLE WITH PE PIPE

SUPPLIER	TESSCO	
	LENGTH (FT)	TOTAL WEIGHT (LBS)
TYPE 6	1000	732
	420	402
TYPE 7	1000	1006
	550	553

CABLE TYPE TABLE

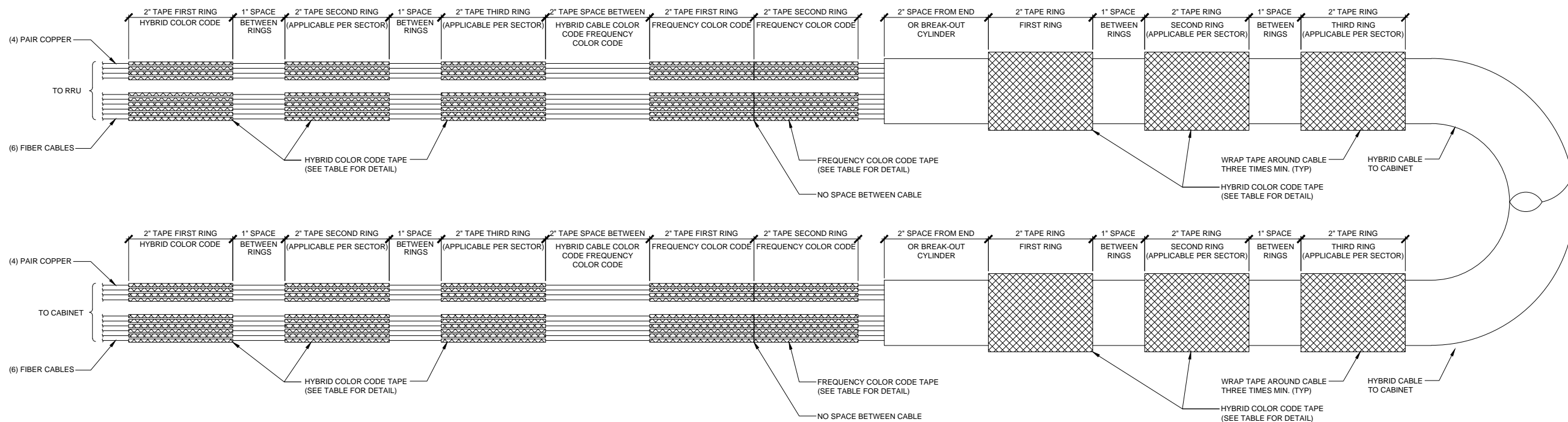

NOTE:

- ALL CABLES SHALL BE MARKED AT THE TOP AND BOTTOM WITH 2" COLORED TAPE OR STENCIL TAG. COLOR TAPE SHALL BE OBTAINED FROM GRAYBAR ELECTRIC.
- THE FIRST RING SHALL BE CLOSEST TO THE END OF THE CABLE AND SPACED APPROXIMATELY 2" FROM AN END CONNECTOR, WEATHERPROOFING, OR BREAK-OUT CYLINDER, WITH 1" SPACE BETWEEN EACH RING.
- THE HYBRID CABLE COLOR SHALL BE APPLIED IN ACCORDANCE WITH THE "TYPICAL HYBRID CABLE COLOR CODE" TABLE ABOVE FOR THE RESPECTIVE SECTOR.
- INDIVIDUAL POWER PAIRS AND FIBER CABLES SHALL BE LABELED WITH BOTH THE HYBRID CABLE COLOR FOR THE RESPECTIVE SECTOR AND A FREQUENCY COLOR CODE IN ACCORDANCE WITH THE "FREQUENCY COLOR CODE FOR PAIRS AND FIBER CABLES OF HYBRID CABLE" TABLE ABOVE.
- A 2" GAP SHALL SEPARATE THE HYBRID CABLE COLOR CODE FROM THE FREQUENCY COLOR CODE.
- THE 2" COLOR RINGS FOR THE FREQUENCY CODE SHALL BE PLACED NEXT TO EACH OTHER WITH NO SPACES.
- THE 2" COLORED TAPE(S) SHALL EACH BE WRAPPED A MINIMUM OF 3 TIMES AROUND THE HYBRID CABLE OR INDIVIDUAL CABLES, AND THE TAPE SHALL BE KEPT IN THE SAME LOCATION AS MUCH AS POSSIBLE.
- COLOR BAND ON JUMPERS SHALL BE 2" WIDE WITH A 2" SPACE.



JUMPER CABLE CONNECTION AT RRU AND ANTENNA



GENERAL DYNAMICS  
Information Technology

1171 WEST 2400 SOUTH  
WEST VALLEY CITY, UT 84119

Technology Associates  
EC Inc.

UTAH MARKET OFFICE  
9847 SOUTH 500 WEST  
SANDY, UTAH 84070  
(801) 463-1020

REV	DATE	DESCRIPTION	BY
C	02/07/2013	ISSUED FOR 90% REVIEW	AC
B	01/21/2013	ISSUED FOR 90% REVIEW	JAA
A	12/03/2012	ISSUED FOR 90% REVIEW	JAA

IT IS A VIOLATION OF LAW FOR ANY PERSON, UNLESS THEY ARE ACTING UNDER THE DIRECTION OF A LICENSED PROFESSIONAL ENGINEER, TO ALTER THIS DOCUMENT.

NETWORK VISION MMS LAUNCH

HUNTSVILLE  
SL54XC068  
750 N. 7200 E.  
HUNTSVILLE, UT 84137

SHEET TITLE  
COLOR CODE  
DETAILS

SHEET NUMBER  
RF-1

NOTE: THE ORIGINAL SIZE OF THIS PLAN IS 24" X 36". SCALE RATIO IS NOT VALID FOR REDUCED OR ENLARGED SHEET SIZES