



Land Use Permit

Weber County Planning Commission

2380 Washington Blvd. STE 240
Ogden, UT 84401
Phone: (801) 399-8791 FAX: (801) 399-8862
webercountyutah.gov/planning

Permit Number: LUP361-2019

Permit Type: Structure
Permit Date: 11/04/2019

Applicant

Name: Derek White
Business:
Address: 1335 N 5900 E
Eden, UT 84310
Phone: 8013883127

Owner

Name: Same as applicant
Business:
Address: , UT
Phone:

Parcel

Parcel: 200020022
Zoning: S-1 **Area:** 9.09 **Sq Ft:** **Lot(s):** **Subdivision:**
Address: 1335 N 5900 E EDEN, UT 84310 **T - R - S - QS: 6N - 1E - 02 - SW**
*If Zoned S-1, See Specific Height Requirements

Proposal

Proposed Structure: 4 ft fence **Building Footprint:** 0
Proposed Structure Height: 4 **Max Structure Height in Zone:** 4
of Dwelling Units: 1 **# of Accessory Bldgs:**
Off Street Parking Reqd: 0 ***Is Structure > 1,000 Sq. Ft?** No
*If True Need Certif. Statement

Permit Checklist

Access Type: Across front lot line **Alternative Access File #** N/A
Greater than 4218 ft above sea level? Yes **Wetlands/Flood Zone?** No
Additional Setback Reqd. ? N/A **Meet Zone Area Frontage?** N/A
> 200 ft from paved Road? N/A **Hillside Review Reqd?** N/A
Culinary Water District: N/A **Waste Water System:** N/A

Comments

Permit issued for a fence not exceeding 4 ft in height, located 33 ft back from centerline of 5900 E.



Land Use Permit

Structure Setback Graphic: New Dwelling, Addition, Etc.

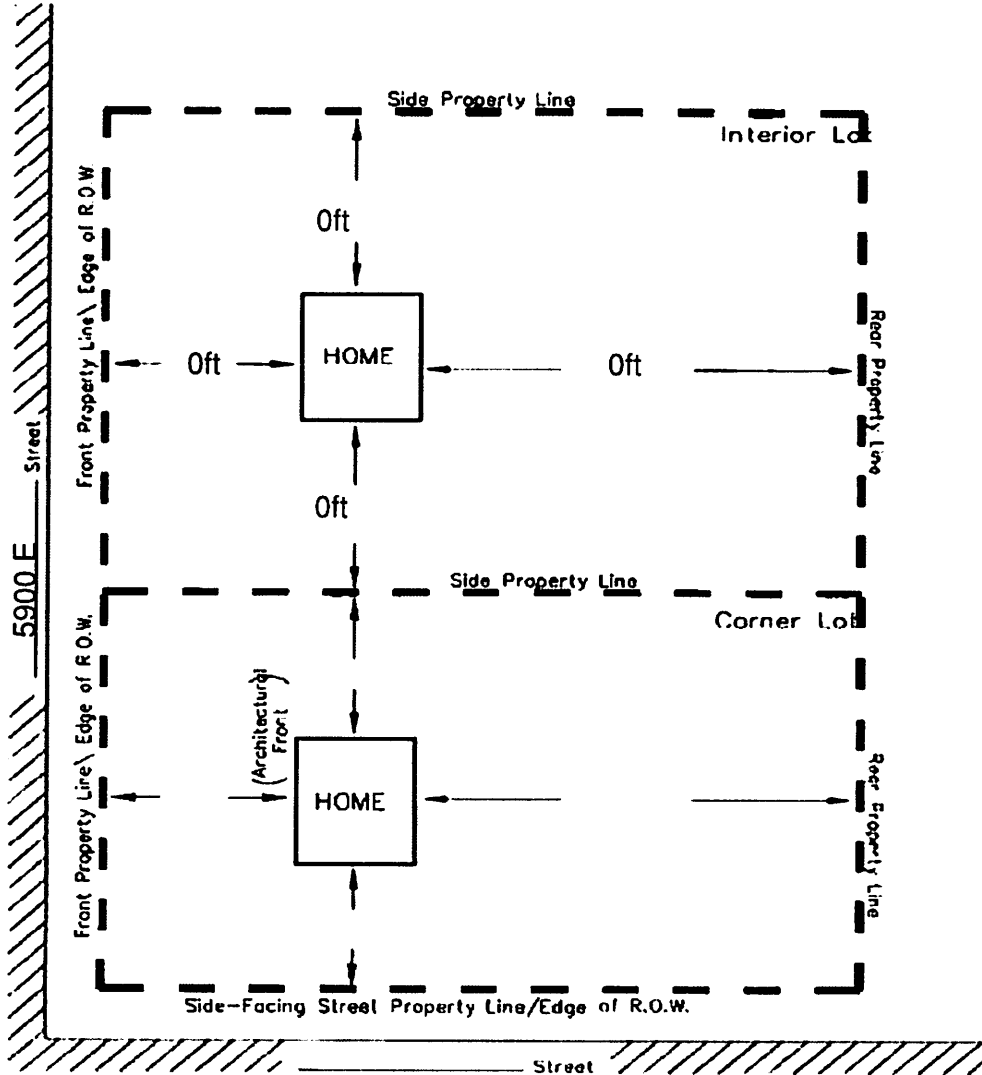

MINIMUM YARD SETBACKS New Dwelling, Addition, Etc.

NOTICE FOR APPLICANT (Please Read Before Signing)

Proposals for the installation of an individual water supply and for a sanitary waste disposal system (septic tank) for any structure designed for human occupation must be approved by Weber County Health Department prior to installation.

Steven Burton 11/04/2019
Planning Dept. Signature of Approval Date

I hereby certify that I have read and examined this application and know the same to be true and correct. All provisions of laws and ordinances governing this land use will be complied with whether specified herein or not. I make this statement under penalty of perjury.

Contractor/Owner Signature of Approval Date