

**POLE PATCH PHASE 3**  
 LOCATED IN THE SOUTHEAST QUARTER OF SECTION 7,  
 TOWNSHIP 7 NORTH, RANGE 1 WEST, SALT LAKE BASE AND MERIDIAN,  
 WEBER COUNTY, UTAH, DECEMBER 2019

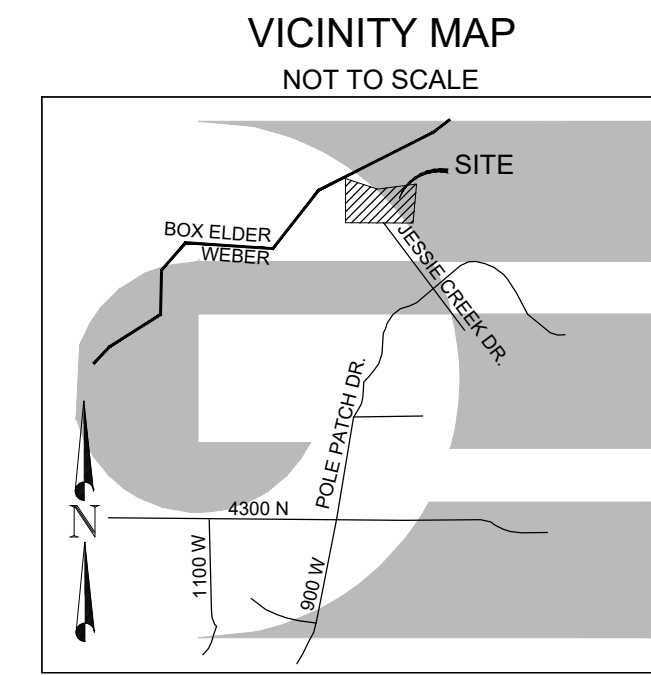

**BOUNDARY DESCRIPTION**

A PART OF THE SOUTHEAST QUARTER OF SECTION 7, TOWNSHIP 7 NORTH, RANGE 1 WEST OF THE SALT LAKE BASE AND MERIDIAN, MORE PARTICULARLY DESCRIBED AS FOLLOWS: BEGINNING AT THE SOUTHEAST CORNER OF SAID SECTION 7; RUNNING THENCE NORTH 89°47'17" WEST 1332.39 FEET ALONG THE SOUTH LINE OF SAID SECTION 7; THENCE NORTH 0°00'00" EAST 586.95 FEET; THENCE SOUTH 72°02'01" EAST 414.96 FEET; THENCE NORTH 7°20'28" WEST 372.80 TO THE WEBER BOX ELDER LINE; THENCE ALONG SAID WEBER BOX ELDER LINE NORTH 55°06'51" EAST 777.75 FEET; THENCE SOUTH 62°04'20" EAST 393.37 FEET; THENCE SOUTH 0°00'00" EAST 1094.30 FEET TO THE POINT OF BEGINNING. CONTAINING 28.93 ACRES.

**SURVEYOR'S CERTIFICATE**

I, KLINT H. WHITNEY, DO HEREBY CERTIFY THAT I AM A LICENSED PROFESSIONAL LAND SURVEYOR IN THE STATE OF UTAH AND THAT I HOLD CERTIFICATE NO. 8227228 IN ACCORDANCE WITH TITLE 58, CHAPTER 22, OF THE PROFESSIONAL ENGINEERS AND LAND SURVEYORS ACT. I FURTHER CERTIFY THAT BY AUTHORITY OF THE OWNERS I HAVE COMPLETED A SURVEY OF THE PROPERTY AS SHOWN AND DESCRIBED ON THIS PLAT, AND HAVE SUBDIVIDED SAID PROPERTY INTO LOTS AND STREETS, TOGETHER WITH EASEMENTS, HEREAFTER TO BE KNOWN AS POLE PATCH PHASE 3 IN ACCORDANCE WITH SECTION 17-23-17 AND HAVE VERIFIED ALL MEASUREMENTS; THAT THE REFERENCE MONUMENTS SHOWN HEREON ARE LOCATED AS INDICATED AND ARE SUFFICIENT TO RETRACE OR REESTABLISH THIS SURVEY; THAT ALL LOTS MEET THE REQUIREMENTS OF THE LAND USE CODE; AND THAT THE INFORMATION SHOWN HEREIN IS SUFFICIENT TO ACCURATELY ESTABLISH THE LATERAL BOUNDARIES OF THE HEREIN DESCRIBED TRACT OF REAL PROPERTY, AND THAT I HAVE PLACED MONUMENTS AS REPRESENTED ON THIS PLAT.

SIGNED THIS \_\_\_\_\_ DAY OF \_\_\_\_\_, 2019.



KLINT H. WHITNEY, PLS NO. 8227228

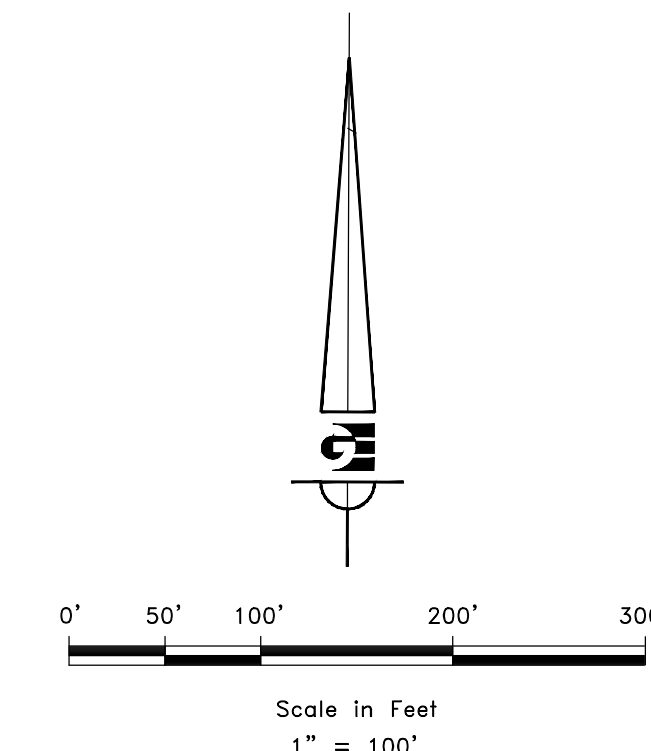

**LEGEND**

- ◆ WEBER COUNTY MONUMENT AS NOTED
- SET 24" REBAR AND CAP MARKED GARDNER ENGINEERING
- SUBDIVISION BOUNDARY
- LOT LINE
- - - ADJACENT PARCEL
- - - SECTION LINE
- - - EXISTING UTILITY EASEMENT
- - - PUBLIC UTILITY EASEMENT
- - - EXISTING ACCESS AND UTILITY EASEMENT
- - - EXISTING FENCE LINE
- ▨ PRIVATE ACCESS EASEMENT

**OWNER'S DEDICATION**

I THE UNDERSIGNED OWNER OF THE HEREON DESCRIBED TRACT OF LAND, HEREBY SET APART AND SUBDIVIDE THE SAME INTO LOTS, PARCELS AND STREETS AS SHOWN ON THIS PLAT AND NAME SAID TRACT:

**POLE PATCH PHASE 3**

AND HEREBY DEDICATE, GRANT AND CONVEY AND RESERVE UNTO THEMSELVES, THEIR HEIRS, THEIR GRANTEEES AND ASSIGNS, A RIGHT-OF-WAY TO BE USED IN COMMON WITH ALL OTHERS WITHIN SAID SUBDIVISION (AND THOSE ADJOINING SUBDIVISIONS THAT MAY BE SUBDIVIDED BY THE UNDERSIGNED OWNERS, THEIR SUCCESSORS, OR ASSIGNS) ON OVER AND ACROSS ALL THOSE PORTIONS OR PARTS OF SAID TRACT OF LAND DESIGNATED ON SAID PLAT AS PRIVATE STREETS (PRIVATE RIGHTS-OF-WAY) AS ACCESS TO THE INDIVIDUAL LOTS, TO BE MAINTAINED BY A LOT OWNERS ASSOCIATION WHOSE MEMBERSHIP CONSISTS OF SAID OWNERS, THEIR GRANTEEES, SUCCESSORS, OR ASSIGNS, AND ALSO GRANT AND DEDICATE A PERPETUAL EASEMENT OVER, UPON AND UNDER THE LANDS DESIGNATED ON THE PLAT AS PUBLIC UTILITY, THE SAME TO BE USED FOR THE INSTALLATION, MAINTENANCE AND OPERATION OF PUBLIC UTILITY SERVICE LINES, STORM DRAINAGE FACILITIES OR FOR THE PERPETUAL PRESERVATION OF WATER DRAINAGE CHANNELS IN THEIR NATURAL STATE WHICHEVER IS APPLICABLE AS MAY BE AUTHORIZED BY WEBER COUNTY, UTAH, WITH NO BUILDINGS OR STRUCTURES BEING ERRECTED WITHIN SUCH EASEMENTS, AND ALSO GRANT DEDICATE AND CONVEY TO THE OWNERS OF PARCEL #160040007 THEIR SUCCESSORS AND ASSIGNS A PRIVATE ACCESS EASEMENT FOR THE PURPOSES OF INGRESS AND EGRESS OVER AND UPON THE LANDS SHOWN AND DESCRIBED HERON AS PRIVATE ACCESS EASEMENT, AND ALSO DEDICATE, GRANT AND CONVEY TO WEBER COUNTY A TEMPORARY TURN AROUND EASEMENT AS SHOWN HEREON TO BE USED BY WEBER COUNTY AND ANY OTHER GOVERNMENTAL OR QUASI GOVERNMENTAL BODY HAVING JURISDICTION OVER SUCH LAND, A PERPETUAL EASEMENT OF AND ACROSS TEMPORARY TURN AROUND EASEMENT FOR THE PURPOSE OF PROVIDING POLICE AND FIRE PROTECTION PROVIDING EMERGENCY MEDICAL SERVICES AND PROVIDING ANY OTHER GOVERNMENTAL OR MUNICIPAL SERVICE UNTIL SUCH TIME THAT THE ROAD IS EXTENDED. THE TEMPORARY TURN AROUND EASEMENT SHALL BE REVOKED AND NULLIFIED AT THE EVENT OF THE EXTENSION OF THE ROAD WITHOUT FURTHER WRITTEN DOCUMENT AND THE ENCUMBERED LAND WITHIN THE AFFECTED PROPERTY SHALL BE RELEASED FOR THE FULL AND EXCLUSIVE USE AND BENEFIT OF THE PROPERTY OWNERS.

SIGNED THIS \_\_\_\_\_ DAY OF \_\_\_\_\_, 2019.

WADMAN INVESTMENTS

PRINTED NAME/TITLE

SIGNATURE

**ACKNOWLEDGEMENT**

STATE OF UTAH )  
 COUNTY OF WEBER )  
 On this \_\_\_\_\_ day of \_\_\_\_\_, 2019, personally appeared before me \_\_\_\_\_, whose identity is personally known to me (or proven on the basis of satisfactory evidence) and who by me duly sworn/affirmed, did say that he is the \_\_\_\_\_ of WADMAN INVESTMENTS, and that said document was signed by him/her in behalf of said "Corporation by Authority of its Bylaws, or (Resolution of its Board of Directors), and said \_\_\_\_\_ acknowledged to me that said "Corporation executed the same.

STAMP

NOTARY PUBLIC

**NOTES**

- CURRENT ZONING - WEBER COUNTY A-1
- SUBJECT PROPERTY FALLS WITHIN FEMA FLOOD ZONE "X" - AREAS DETERMINED TO BE OUTSIDE THE 0.2% ANNUAL CHANCE FLOODPLAIN, PER FEMA MAP NO. 49057C0205F WITH AN EFFECTIVE DATE OF JUNE 2, 2015
- IF ALTERNATE ACCESS IS APPROVED, THE LANDOWNER OF RECORD OR AUTHORIZED REPRESENTATIVE SHALL AGREE TO PAY A PROPORTIONATE AMOUNT OF THE COSTS ASSOCIATED WITH DEVELOPING A STREET IF, AT ANY TIME IN THE FUTURE, THE COUNTY DEEMS IT NECESSARY TO HAVE THE LANDOWNER REPLACE THE PRIVATE RIGHT OF WAY/EASEMENT WITH A STREET THAT WOULD SERVE AS A REQUIRED ACCESS TO ADDITIONAL LOTS. THE AGREEMENT SHALL BE IN THE FORM CONSIDERED APPROPRIATE AND ACCEPTABLE TO THE OFFICE OF THE WEBER COUNTY RECORDER AND SHALL RECITE AND EXPLAIN ALL MATTERS OF FACT, INCLUDING A LOT/PARCEL BOUNDARY DESCRIPTION, WHICH ARE NECESSARY TO MAKE THE AGREEMENT INTELLIGIBLE AND SHOW ITS SUCCESSIVE NATURE.

AGRICULTURAL NOTE:  
 AGRICULTURE IS THE PREFERRED USE IN THE AGRICULTURE ZONES. AGRICULTURE OPERATIONS AS SPECIFIED IN THE ZONING ORDINANCE FOR A PARTICULAR ZONE ARE PERMITTED AT ANY TIME INCLUDING THE OPERATION OF FARM MACHINERY AND NO ALLOWED AGRICULTURE USE SHALL BE SUBJECT TO RESTRICTION ON THAT IT INTERFERES WITH ACTIVITIES OF FUTURE RESIDENTS OF THIS SUBDIVISION.

**NARRATIVE**

THE PURPOSE OF THIS SURVEY WAS TO CREATE A THREE LOT SUBDIVISION OF THE PROPERTY AS SHOWN AND DESCRIBED HEREON. THE SURVEY WAS ORDERED BY SPENCER BRADLEY ON BEHALF OF WADMAN INVESTMENTS. THE CONTROL USED TO ESTABLISH THE BOUNDARY WAS THE EXISTING WEBER COUNTY SURVEY MONUMENTATION AND FOUND PROPERTY CORNERS AS SHOWN AND NOTED HEREON. THE BASIS OF BEARING IS THE SOUTH LINE OF THE SOUTHEAST QUARTER OF SECTION 7, TOWNSHIP 7 NORTH, RANGE 1 WEST, OF THE SALT LAKE BASE AND MERIDIAN WHICH BEARS NORTH 89°47'17" WEST WEBER COUNTY, UTAH NORTH, NAD 83 STATE PLANE GRID BEARING. PROPERTY BOUNDARY WAS DETERMINED BY RECORD OF SURVEY #3448, FOUND PROPERTY CORNERS WITHIN THE POLE PATCH DEVELOPMENT AND EXISTING WEBER COUNTY SURVEY MONUMENTATION. OWNERSHIP WAS DETERMINED BY QUIT CLAIM DEED RECORDED AS ENTRY NUMBER 2539143.

**TYPICAL ACCESS EASEMENT CROSS SECTION (N.T.S.)**

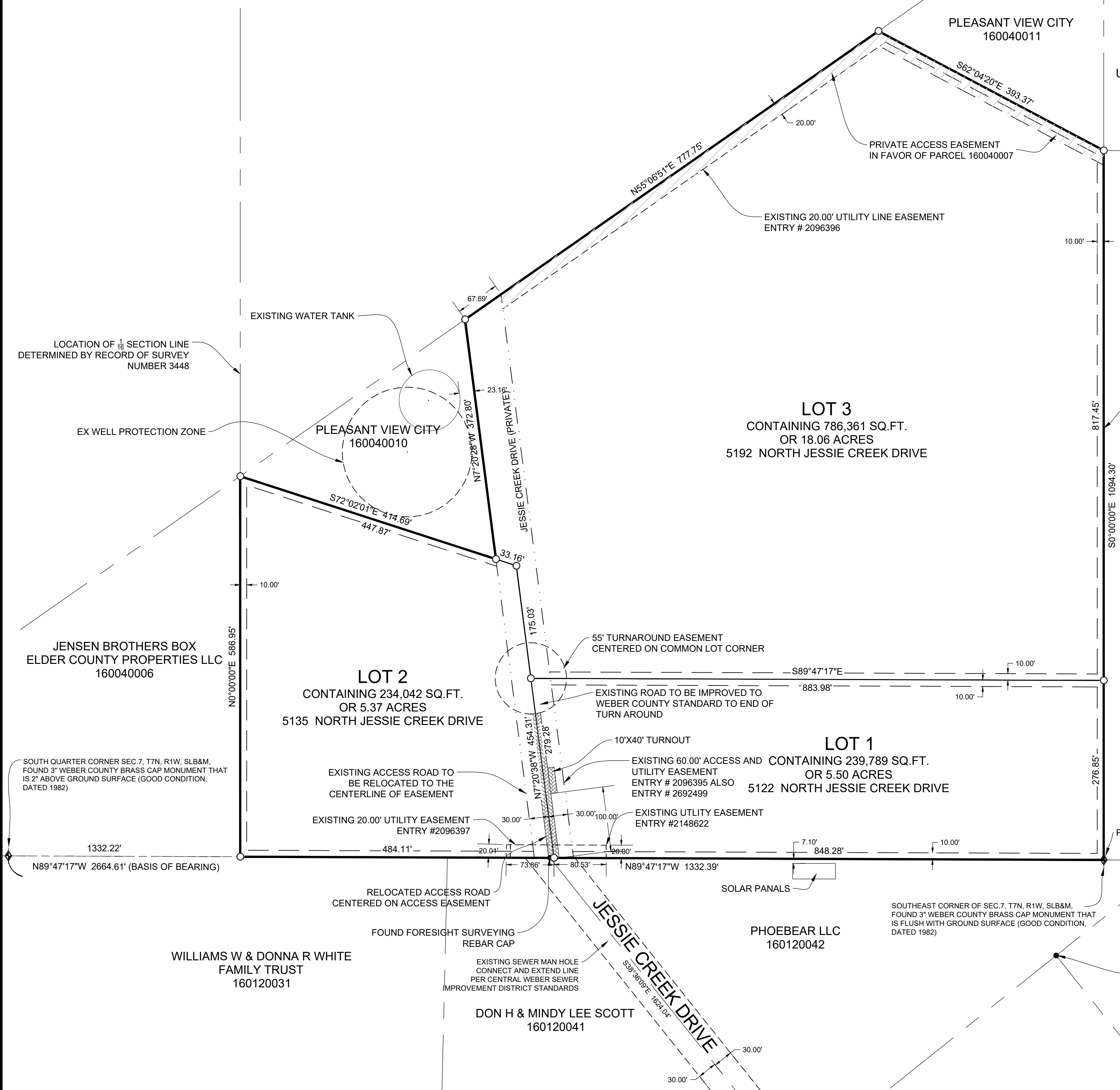
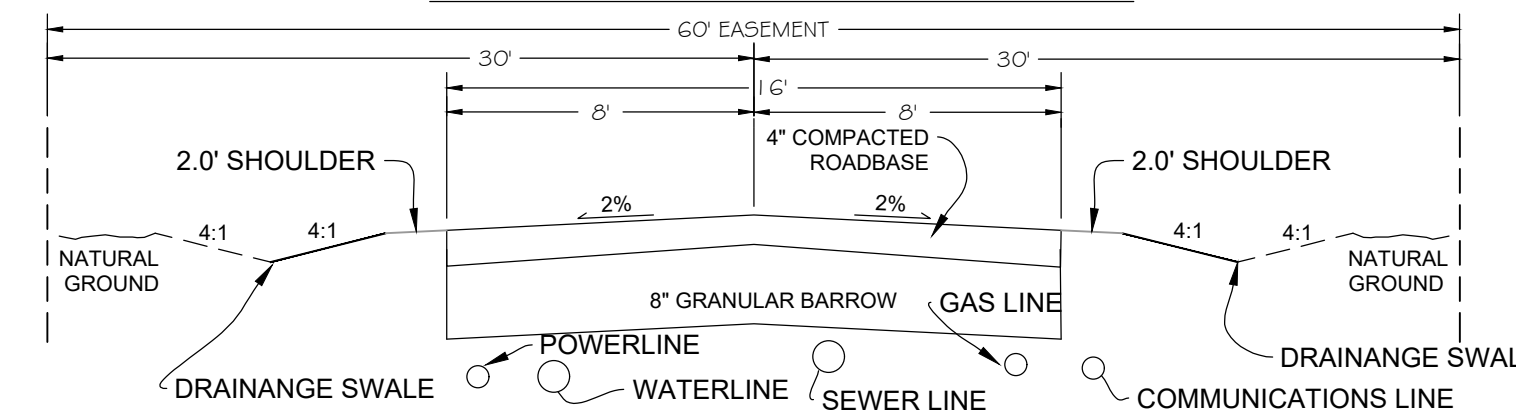

<p><b>WEBER COUNTY SURVEYOR</b></p> <p>I HEREBY CERTIFY THAT THE WEBER COUNTY SURVEYORS OFFICE HAS REVIEWED THIS PLAT AND ALL CONDITIONS FOR APPROVAL BY THIS OFFICE HAVE BEEN SATISFIED. THE APPROVAL OF THIS PLAT BY THE WEBER COUNTY SURVEYOR DOES NOT RELIEVE THE LICENSED LAND SURVEYOR WHO EXECUTED THIS PLAT FROM THE RESPONSIBILITIES AND/OR LIABILITIES ASSOCIATED THEREWITH.</p> <p>SIGNED THIS _____ DAY OF _____, 2019.</p> <p>_____                  COUNTY SURVEYOR</p>	<p><b>WEBER COUNTY ATTORNEY</b></p> <p>I HAVE EXAMINED THE FINANCIAL GUARANTEE AND OTHER DOCUMENTS ASSOCIATED WITH THIS SUBDIVISION PLAT AND IN MY OPINION THEY CONFORM WITH THE COUNTY ORDINANCE APPLICABLE THERETO AND NOW IN FORCE AND EFFECT.</p> <p>SIGNED THIS _____ DAY OF _____, 2019.</p> <p>_____                  COUNTY ATTORNEY</p>	<p><b>WEBER COUNTY ENGINEER</b></p> <p>I HEREBY CERTIFY THAT THE REQUIRED PUBLIC IMPROVEMENT STANDARDS AND DRAWINGS FOR THIS SUBDIVISION CONFORM WITH COUNTY STANDARDS AND THE AMOUNT OF THE FINANCIAL GUARANTEE IS SUFFICIENT FOR THE INSTALLATION OF THESE IMPROVEMENTS.</p> <p>SIGNED THIS _____ DAY OF _____, 2019.</p> <p>_____                  COUNTY ENGINEER</p>	<p><b>WEBER COUNTY COMMISSION ACCEPTANCE</b></p> <p>THIS IS TO CERTIFY THAT THIS SUBDIVISION PLAT, THE DEDICATION OF STREETS AND OTHER PUBLIC WAYS AND FINANCIAL GUARANTEE OF PUBLIC IMPROVEMENTS ASSOCIATED WITH THIS SUBDIVISION THEREON ARE HEREBY APPROVED AND ACCEPTED BY THE COMMISSIONERS OF WEBER COUNTY, UTAH.</p> <p>SIGNED THIS _____ DAY OF _____, 2019.</p> <p>CHAIRMAN, WEBER COUNTY COMMISSION</p> <p>ATTEST: _____                  NAME/TITLE</p>	<p><b>WEBER COUNTY PLANNING COMMISSION APPROVAL</b></p> <p>THIS IS TO CERTIFY THAT THIS SUBDIVISION WAS DULY APPROVED BY THE WEBER COUNTY PLANNING COMMISSION.</p> <p>SIGNED THIS _____ DAY OF _____, 2019.</p> <p>CHAIRMAN, WEBER COUNTY PLANNING COMMISSION</p>
---	--	---	--	---

DEVELOPER: WADMAN INVESTMENTS SPENCER BRADLEY 2920 S 925 W OGDEN, UTAH 801-621-4185	<b>S1</b> <b>1</b>	COUNTY RECORDER ENTRY NO. _____ FEE PAID _____ FILED FOR AND RECORDED _____ AT _____ IN BOOK _____ OF OFFICIAL _____ RECORDS, PAGE _____ RECORDED _____ FOR _____ COUNTY RECORDER _____ BY: _____
		<p><b>GARDNER ENGINEERING</b>                  CIVIL • LAND PLANNING                  MUNICIPAL • LAND SURVEYING                  5150 SOUTH 875 EAST OGDEN, UT                  OFFICE: 801-476-0202 FAX: 801-476-0066</p>

P:\2027 - WADMAN\1801 - 5 LOT AT POLE PATCH\REVISED\SUBDIVISION PLAT.DWG