

TAYLOR ANDERSON SUBDIVISION

LOCATED IN THE SOUTHWEST QUARTER OF SECTION 36,
TOWNSHIP 7 NORTH, RANGE 3 WEST, SALT LAKE BASE AND MERIDIAN,
WEBER COUNTY, UTAH
JUNE 2019

BOUNDARY DESCRIPTION

A PART OF LOT 4 "PLAT OF SECTION 36" LOCATED IN THE SOUTHWEST QUARTER OF SECTION 36, TOWNSHIP 7 NORTH, RANGE 3 WEST, SALT LAKE BASE AND MERIDIAN, MORE PARTICULARLY DESCRIBED AS FOLLOWS:
BEGINNING AT A POINT ON THE WEST LINE OF SAID LOT 4 ALSO BEING ON THE WEST LINE OF THE SOUTHWEST QUARTER OF SAID SECTION 36 BEING LOCATED NORTH 00°11'27" EAST 2224.94 FEET ALONG SAID WEST LINE FROM THE SOUTHWEST CORNER OF SAID SECTION; RUNNING THENCE ALONG SAID WEST LINE NORTH 00°11'27" EAST 150.00 FEET; THENCE SOUTH 89°48'33" EAST 373.75 FEET; THENCE SOUTH 00°04'35" WEST 366.11 FEET TO THE SOUTH LINE OF SAID LOT 4; THENCE ALONG SAID SOUTH LINE NORTH 89°54'17" WEST 168.32 FEET; THENCE NORTH 00°11'27" EAST 214.50 FEET; THENCE NORTH 89°17'05" WEST 206.17 FEET TO THE POINT OF BEGINNING. CONTAINING 92,634 SQUARE FEET.

SURVEYOR'S CERTIFICATE

I, KLINT H. WHITNEY, DO HEREBY CERTIFY THAT I AM A LICENSED PROFESSIONAL LAND SURVEYOR IN THE STATE OF UTAH AND THAT I HOLD CERTIFICATE NO. 8227228 IN ACCORDANCE WITH TITLE 58, CHAPTER 22, OF THE PROFESSIONAL ENGINEERS AND LAND SURVEYORS ACT; I FURTHER CERTIFY THAT BY AUTHORITY OF THE OWNERS I HAVE COMPLETED A SURVEY OF THE PROPERTY AS SHOWN AND DESCRIBED ON THIS PLAT, AND HAVE SUBDIVIDED SAID PROPERTY INTO LOTS AND STREETS, TOGETHER WITH EASEMENTS, HEREAFTER TO BE KNOWN AS TAYLOR ANDERSON SUBDIVISION IN ACCORDANCE WITH SECTION 17-23-17 AND HAVE VERIFIED ALL MEASUREMENTS; THAT THE REFERENCE MONUMENTS SHOWN HEREON ARE LOCATED AS INDICATED AND ARE SUFFICIENT TO RETRACE OR REESTABLISH THIS SURVEY; THAT ALL LOTS MEET THE REQUIREMENTS OF THE LAND USE CODE; AND THAT THE INFORMATION SHOWN HEREIN IS SUFFICIENT TO ACCURATELY ESTABLISH THE LATERAL BOUNDARIES OF THE HEREIN DESCRIBED TRACT OF REAL PROPERTY.

SIGNED THIS _____ DAY OF _____, 2019.

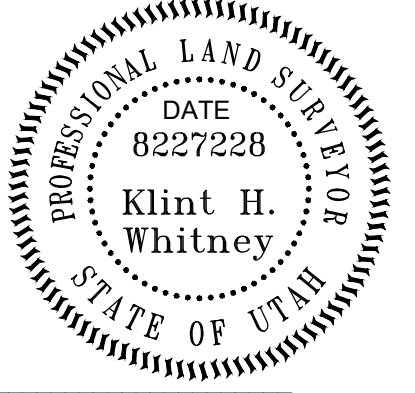

KLINT H. WHITNEY, PLS NO. 8227228

OWNER'S DEDICATION

I THE UNDERSIGNED OWNER OF THE HEREON DESCRIBED TRACT OF LAND, HEREBY SET APART AND SUBDIVIDE THE SAME INTO LOTS, PARCELS AND STREETS AS SHOWN ON THIS PLAT AND NAME SAID TRACT:

TAYLOR ANDERSON SUBDIVISION

AND HEREBY DEDICATE, GRANT AND CONVEY TO WEBER COUNTY, UTAH ALL THOSE PARTS OR PORTIONS OF SAID TRACT OF LAND DESIGNATED AS ROADWAY DEDICATION, THE SAME TO BE USED AS PUBLIC THOROUGHFARES FOREVER, AND ALSO GRANT AND DEDICATE A PERPETUAL EASEMENT OVER, UPON AND UNDER THE LANDS DESIGNATED ON THE PLAT AS PUBLIC UTILITY, THE SAME TO BE USED FOR THE INSTALLATION, MAINTENANCE AND OPERATION OF PUBLIC UTILITY SERVICE LINES, STORM DRAINAGE FACILITIES OR FOR THE PERPETUAL PRESERVATION OF WATER DRAINAGE CHANNELS IN THEIR NATURAL STATE WHICHEVER IS APPLICABLE AS MAY BE AUTHORIZED BY WEBER COUNTY, UTAH, WITH NO BUILDINGS OR STRUCTURES BEING ERECTED WITHIN SUCH EASEMENTS.

SIGNATURE _____ DATE: _____
EDWARD H. HARBERTSON, JR. AS TO AN UNDIVIDED 3/6THS INTEREST

SIGNATURE _____ DATE: _____
STACEY LEE ADAMS AS TO AN UNDIVIDED 1/6TH INTEREST

SIGNATURE _____ DATE: _____
DOUGLAS JAMES HARBERTSON AS TO AN UNDIVIDED 1/6TH INTEREST

SIGNATURE _____ DATE: _____
GUY PAUL HARBERTSON AS TO AN UNDIVIDED 1/6TH INTEREST

ACKNOWLEDGEMENT

STATE OF UTAH)
COUNTY OF WEBER)

On this _____ day of _____, 2019, before me _____, A Notary Public, personally appeared
EDWARD H. HARBERTSON, JR. Proved on the basis of satisfactory evidence to be the person(s) whose name(s) (is/are) subscribed to this instrument, and acknowledged (he/she/they) executed the same. Witness my hand and official seal.

ACKNOWLEDGEMENT

STATE OF UTAH)
COUNTY OF WEBER)

On this _____ day of _____, 2019, before me _____, A Notary Public, personally appeared
STACEY LEE ADAMS. Proved on the basis of satisfactory evidence to be the person(s) whose name(s) (is/are) subscribed to this instrument, and acknowledged (he/she/they) executed the same. Witness my hand and official seal.

STAMP _____ NOTARY PUBLIC

ACKNOWLEDGEMENT

STATE OF UTAH)
COUNTY OF WEBER)

On this _____ day of _____, 2019, before me _____, A Notary Public, personally appeared
DOUGLAS JAMES HARBERTSON. Proved on the basis of satisfactory evidence to be the person(s) whose name(s) (is/are) subscribed to this instrument, and acknowledged (he/she/they) executed the same. Witness my hand and official seal.

STAMP _____ NOTARY PUBLIC

ACKNOWLEDGEMENT

STATE OF UTAH)
COUNTY OF WEBER)

On this _____ day of _____, 2019, before me _____, A Notary Public, personally appeared
GUY PAUL HARBERTSON. Proved on the basis of satisfactory evidence to be the person(s) whose name(s) (is/are) subscribed to this instrument, and acknowledged (he/she/they) executed the same. Witness my hand and official seal.

STAMP _____ NOTARY PUBLIC

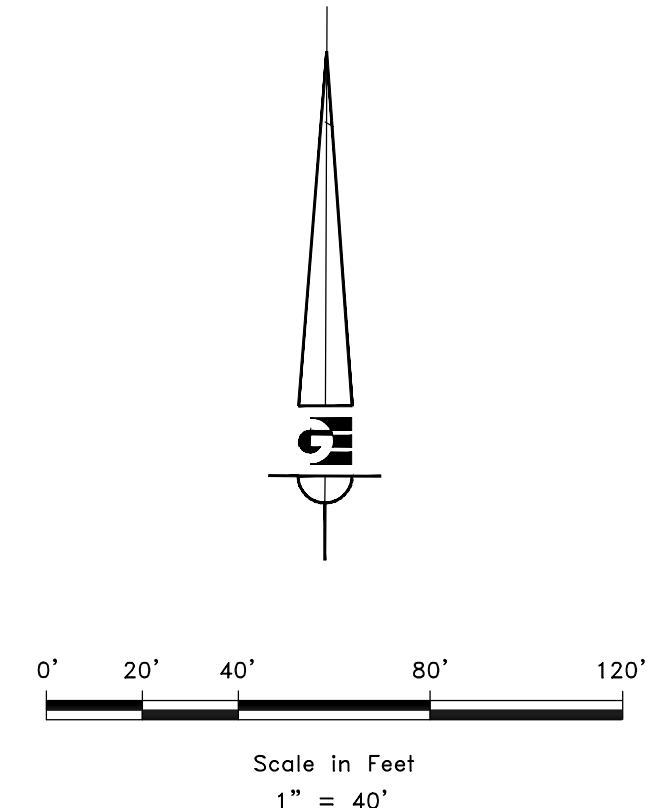
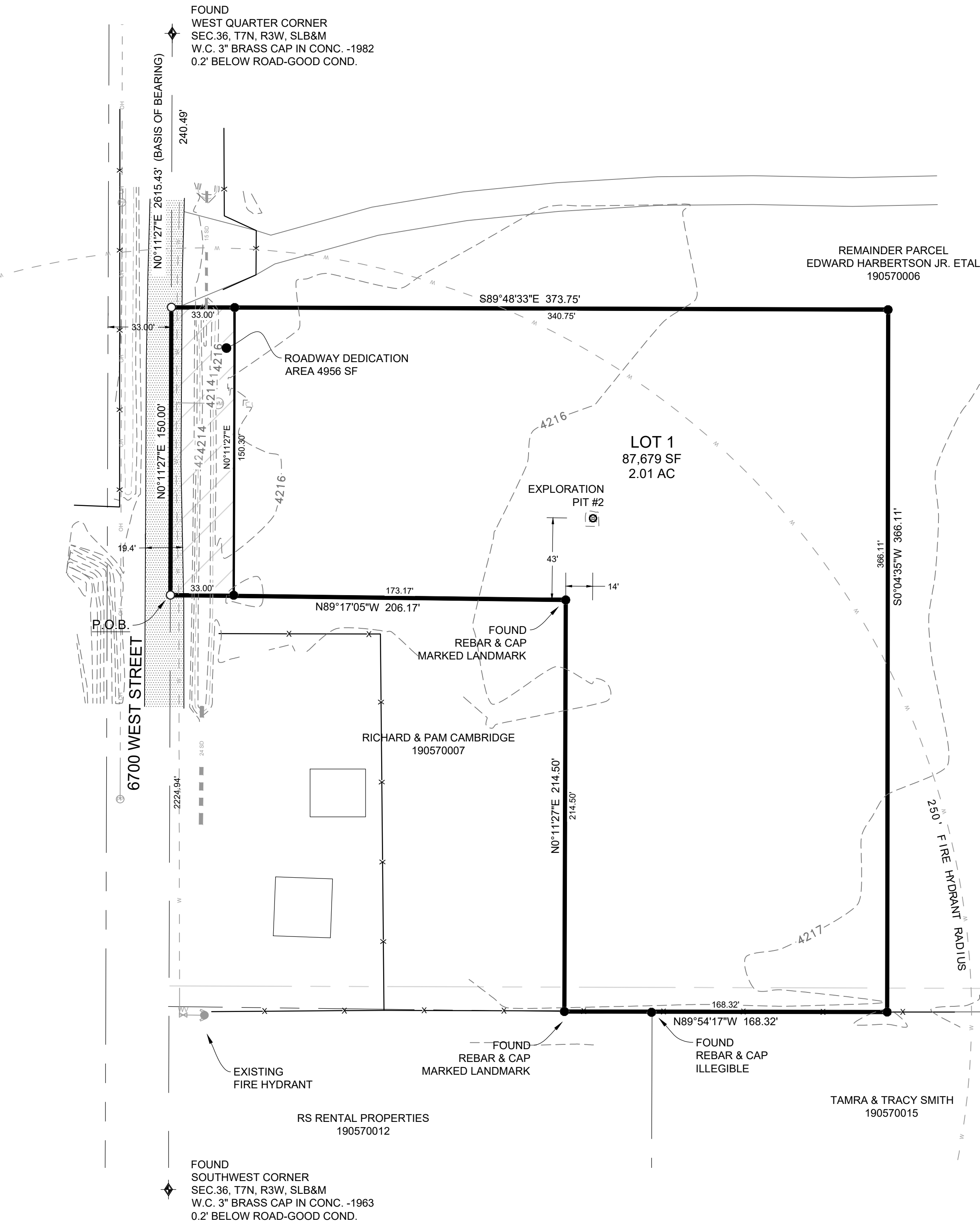

LEGEND

- ◆ WEBER COUNTY MONUMENT AS NOTED
- SET 24" REBAR AND CAP MARKED GARDNER ENGINEERING
- FOUND REBAR AND CAP MARKED GARDNER ENGINEERING (UNLESS OTHERWISE NOTED)
- SUBDIVISION BOUNDARY
- LOT LINE
- - - ADJACENT PARCEL
- - - SECTION LINE
- - - EASEMENT
- x - EXISTING FENCE LINE
- - - EXISTING WATER LINE
- - - EXISTING STORM DRAIN
- - - EXISTING OVERHEAD POWER
- - - EXISTING ASPHALT
- ⊙ EXISTING WATER METER
- ⊕ EXISTING FIRE HYDRANT
- ⊕ EXISTING WATER VALVE
- ⊕ EXISTING POWER POLE

VICINITY MAP

NOT TO SCALE

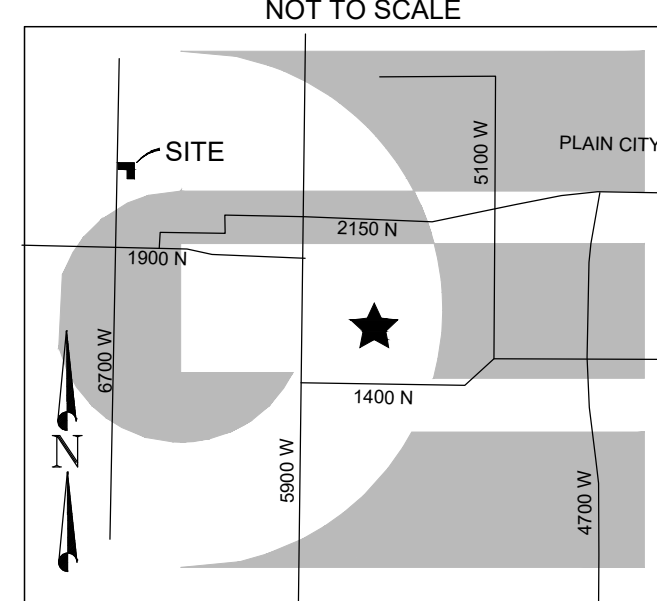

SOIL NOTES

EXPLORATION PIT #2 (WASTE WATER SITE AND SOILS EVALUATION #14818)
0-15" Loam, GRANULAR STRUCTURE
15-40" SILTY CLAY LOAM, BLOCKY STRUCTURE
46-62" SILT LOAM, BLOCKY STRUCTURE
OBSERVED GROUNDWATER TABLE 62"
DOCUMENTED GROUNDWATER TABLE 12"

NOTES

- ZONE (A-2) CURRENT YARD SETBACKS: FRONT-30' // SIDE-10' TOTAL WIDTH OF 2 SIDE YARDS NOT LESS THAN 24' // REAR-30'
- SUBJECT PROPERTY FALLS WITHIN FEMA FLOOD ZONE "X" - AREAS DETERMINED TO BE OUTSIDE THE 0.2% ANNUAL CHANCE FLOODPLAIN. PER FEMA MAP NO. 49057C0175E WITH AN EFFECTIVE DATE OF DECEMBER 16, 2005.

AGRICULTURAL NOTE:
AGRICULTURE IS THE PREFERRED USE IN THE AGRICULTURE ZONES. AGRICULTURE OPERATIONS AS SPECIFIED IN THE ZONING ORDINANCE FOR A PARTICULAR ZONE ARE PERMITTED AT ANY TIME INCLUDING THE OPERATION OF FARM MACHINERY AND NO ALLOWED AGRICULTURE USE SHALL BE SUBJECT TO RESTRICTION ON THAT IT INTERFERES WITH ACTIVITIES OF FUTURE RESIDENTS OF THIS SUBDIVISION.

WEBER COUNTY SURVEYOR
I HEREBY CERTIFY THAT THE WEBER COUNTY SURVEYOR'S OFFICE HAS REVIEWED THIS PLAT FOR MATHEMATICAL CORRECTNESS, SECTION CORNER DATA, AND FOR HARMONY WITH LINES AND MONUMENTS ON RECORD IN COUNTY OFFICES. THE APPROVAL OF THIS PLAT BY THE WEBER COUNTY SURVEYOR DOES NOT RELIEVE THE LICENSED LAND SURVEYOR WHO EXECUTED THIS PLAT FROM THE RESPONSIBILITIES AND/OR LIABILITIES ASSOCIATED THEREWITH.
SIGNED THIS _____ DAY OF _____, 2019.
COUNTY SURVEYOR

WEBER COUNTY ATTORNEY
I HAVE EXAMINED THE FINANCIAL GUARANTEE AND OTHER DOCUMENTS ASSOCIATED WITH THIS SUBDIVISION PLAT AND IN MY OPINION THEY CONFORM WITH THE COUNTY ORDINANCE APPLICABLE THERETO AND NOW IN FORCE AND EFFECT.
SIGNED THIS _____ DAY OF _____, 2019.
COUNTY ATTORNEY

WEBER COUNTY ENGINEER
I HEREBY CERTIFY THAT THE REQUIRED PUBLIC IMPROVEMENT STANDARDS AND DRAWINGS FOR THIS SUBDIVISION CONFORM WITH COUNTY STANDARDS AND THE AMOUNT OF THE FINANCIAL GUARANTEE IS SUFFICIENT FOR THE INSTALLATION OF THESE IMPROVEMENTS.
SIGNED THIS _____ DAY OF _____, 2019.
COUNTY ENGINEER

WEBER COUNTY COMMISSION ACCEPTANCE
THIS IS TO CERTIFY THAT THIS SUBDIVISION PLAT, THE DEDICATION OF STREETS AND OTHER PUBLIC WAYS AND FINANCIAL GUARANTEE OF PUBLIC IMPROVEMENTS ASSOCIATED WITH THIS SUBDIVISION THEREON ARE HEREBY APPROVED AND ACCEPTED BY THE COMMISSIONERS OF WEBER COUNTY, UTAH.
SIGNED THIS _____ DAY OF _____, 2019.
CHAIRMAN, WEBER COUNTY COMMISSION
ATTEST: _____
NAME/TITLE

WEBER COUNTY PLANNING COMMISSION APPROVAL
THIS IS TO CERTIFY THAT THIS SUBDIVISION WAS DULY APPROVED BY THE WEBER COUNTY PLANNING COMMISSION.
SIGNED THIS _____ DAY OF _____, 2019.
CHAIRMAN, WEBER COUNTY PLANNING COMMISSION

WEBER - MORGAN HEALTH DEPARTMENT
I DO HEREBY CERTIFY THAT THE SOILS, PERCOLATION RATES, AND SITE CONDITION FOR THIS SUBDIVISION HAVE BEEN INVESTIGATED BY THIS OFFICE AND ARE APPROVED FOR ON-SITE WASTEWATER DISPOSAL SYSTEMS.
SIGNED THIS _____ DAY OF _____, 2019.
DIRECTOR WEBER-MORGAN HEALTH DEPT.

NARRATIVE

THE PURPOSE OF THIS SURVEY WAS TO CREATE A 1 LOT SUBDIVISION WITH REMAINDER PARCEL AS SHOWN AND NOTED HEREON. SEE RECORD OF SURVEY #6129. SURVEY WAS ORDERED BY TAYLOR ANDERSON. THE BASIS OF BEARING IS THE WEST LINE OF THE SOUTHWEST QUARTER OF SECTION 36, TOWNSHIP 7 NORTH, RANGE 3 WEST, OF THE SALT LAKE BASE AND MERIDIAN WHICH BEARS NORTH 00°11'27" EAST WEBER COUNTY, UTAH NORTH, NAD 83 STATE PLANE GRID BEARING. WARRANTY DEED RECORDED AS ENTRY NUMBER 2915375. DEEDS OF ADJOINING PROPERTIES, THE PLAT OF SECTION 36 BOOK 6 PAGE 71 AND EXISTING FENCE LINES WERE USED TO DETERMINE BOUNDARY LOCATION.

DEVELOPER: NAME _____ ADDRESS _____ OGDEN, UT 84401 801-XXX-XXX	S1	1	COUNTY RECORDER ENTRY NO. _____ FEE PAID _____ FILED FOR AND RECORDED _____ AT _____ IN BOOK _____ OF OFFICIAL _____ RECORDS, PAGE _____ RECORDED _____ FOR _____ COUNTY RECORDER _____ BY: _____
GARDNER ENGINEERING CIVIL - LAND PLANNING MUNICIPAL - LAND SURVEYING 5150 SOUTH 375 EAST OGDEN, UT OFFICE: 801.476.0202 FAX: 801.476.0066			