

# Hadley Homestead Subdivision

A part of the Northeast 1/4 of Section 29, T6N, R2W, SLB&M, U.S. Survey  
West Haven City, Weber County, Utah

The Northeast Corner of the Northeast 1/4 of Section 29, T6N, R2W, SLB&M, U.S. Survey (Not Found Positioned Using Information on Tie Sheet)

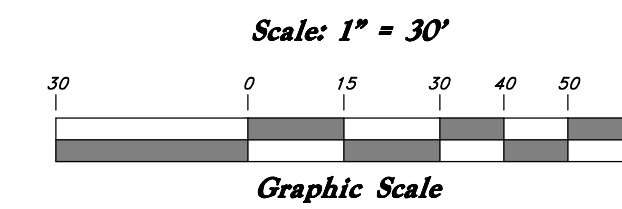
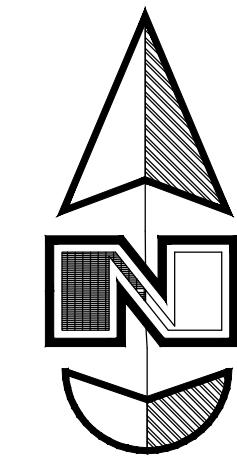

### LEGEND

- ▲ Set Nail & Washer
- Set Rebar & GBE Cap
- w/ Fencepost
- ⊙ Set Hub & Tack
- ⊕ Monument to be set
- ⊖ Existing Fence Line
- ⊘ Found Rebar & Cap
- ⊙ Radial Line
- (N/R) Non-Radial Line
- Measured Distances
- Zone Boundary Line
- Public Utility and Drainage Easement
- PU&D

### SURVEYOR'S CERTIFICATE

I, Andy Hubbard, do hereby certify that I am a Registered Professional Land Surveyor in the State of Utah, and that I hold Certificate No. 6242920 in accordance with Title 58 Chapter 22, Professional Engineers and Land Surveyors Licensing Act. I also do hereby certify that Hadley Homestead Subdivision in Weber County, Utah has been correctly drawn to the designated scale and is a true and correct representation of the following description of lands included in said subdivision, based on data compiled from records in the Weber County Recorder's Office, and of a survey made on the ground in accordance with Section 17-23-17. Monumented Lot corners have been set as shown on this drawing. I also certify that all the lots within Hadley Homestead Subdivision meet the frontage and area requirements of the Weber County Zoning Ordinance.

Signed this day of \_\_\_\_\_, 2010.

Andy Hubbard

### OWNER'S DEDICATION

The undersigned owner of the hereon described tract of land, hereby sets apart and subdivides the same into lots as shown on this plat and names said tract Hadley Homestead Subdivision, and hereby dedicates, grants, and conveys to Weber County all those parts or portions of said tract of land designated as streets, the same to be used as public thoroughfares forever, and also dedicates to Weber County easements for public utilities and drainage purposes over and across the portions of the lots designated as public utility and drainage easements, the same to be used for the installation, maintenance, and operation of public utility service lines and drainage as may be authorized by Weber County.

Signed this day of \_\_\_\_\_, 2012.

Dennis B. Hadley & WF Lana E. Hadley

### WEBER COUNTY SURVEYOR

I hereby certify that the Weber County Surveyor's Office has reviewed this plat for mathematical correctness, section corner data, and for harmony with the lines and monuments on record in the county offices. The approval of this plat by the Weber County Surveyor does not relieve the Licensed Land Surveyor who executed this plat from the responsibilities and/or liabilities associated therewith.

Signed this day of \_\_\_\_\_, 2012.

Signature

### WEBER COUNTY ATTORNEY

I have examined the financial guarantee and other documents associated with this subdivision plat and in my opinion they conform with the County Ordinance applicable thereto and now in force and effect.

Signed this day of \_\_\_\_\_, 2012.

Signature

### NARRATIVE

This Survey was requested by Mr. Landon Hadley for the purposes of prepare this property to be split into separate parcels.

Brass Cap Monuments were Found at the Southeast Southwest and Northwest corners, and a Witness corner was found referencing the Northeast corner of the Northeast Quarter of Section 29, T6N, R2W, SLB&M.

A line bearing ? between the Southeast and Southwest corners of said Quarter Section was used as the Basis of Bearings.

The Northeast corner was positioned using the Weber County Surveyor's record distances from the Witness corner and the Southeast corner of the Quarter Section.

The Property to the South (Weber School District) is described as an aliquot part of the Northeast Quarter of the Northeast Quarter. This creates a deed gap between 4.8" and 5.2" with the South line this parcel and the adjoining parcel to the West.

The distances from the Section line to the North compute to 660 feet or a perfect 1/8 of a mile. Taking this into account the South line of the property has been adjusted to coincide with the North line of the South half of the Northeast Quarter of the Northeast Quarter as call for in the adjoining deed for the Weber School District Property.

Property corners were monumented as depicted on this drawing

### BOUNDARY DESCRIPTION

A part of the Northeast Quarter of Section 29, Township 6 North, Range 2 West Salt Lake Base and Meridian, U.S. Survey:

Beginning at a point on the West right of way line of 4300 West Street, said point being 332.92 feet South 0°49'03" West along the Section line and 33.00 feet North 89°10'57" West from the Northeast corner of said Quarter Section; and running thence South 00°49'03" West 331.81 feet along said West right of way line to the North line of the South Half of the Northeast Quarter of said Quarter section; thence North 89°04'32" West 627.03 feet along said North line; thence North 00°49'35" East 182.26 feet; thence South 89°02'06" East 327.00 feet; thence North 00°49'03" East 150.00 feet; thence South 89°02'06" East 300.00 feet to the point of beginning.

Contains 3.653 acres.

2666.69' Meas. (2666.09' W.C.S.)

Senders, Trent & Renee

S 0°56'27" W Meas. (S 0°57'12" W W.C.S.)

Southwest Corner of the Northeast 1/4 of Section 29, T6N, R2W, SLB&M, U.S. Survey (Found Brass Cap Monument)

S 89°11'53" E (Basis of Bearings)

2643.01' Calc'd (2642.65' W.C.S.)

State of Utah } ss  
County of \_\_\_\_\_

On the \_\_\_\_\_ day of \_\_\_\_\_, 2012, personally appeared before me, the undersigned Notary Public, the signers of the above Owner's Dedication, two, in number, who duly acknowledged to me they signed it freely and voluntarily and for the purposes therein mentioned.

Residing At: \_\_\_\_\_ A Notary Public commissioned in Utah

Commission Expires: \_\_\_\_\_ Print Name \_\_\_\_\_

**WEBER COUNTY ENGINEER**

I hereby certify that the required public improvement standards and drawings for this subdivision conform with County standards and the amount of the financial guarantee is sufficient for the installation of these improvements.

Signed this day of \_\_\_\_\_, 2012.

Signature \_\_\_\_\_

**WEBER COUNTY COMMISSION ACCEPTANCE**

This is to certify that this subdivision plat, the dedication of streets and other public ways and financial guarantee of public improvements associated with this subdivision, thereon are hereby approved and accepted by the Commissioners of Weber County, Utah this day of \_\_\_\_\_, 2012.

Title \_\_\_\_\_

Attest \_\_\_\_\_ Chair, Weber County Commission

**WEBER COUNTY RECORDER**

ENTRY NO. \_\_\_\_\_ AT \_\_\_\_\_

FILED FOR RECORD AND \_\_\_\_\_ FEE PAID

RECORDED \_\_\_\_\_

IN BOOK \_\_\_\_\_ OF OFFICIAL RECORDS, PAGE \_\_\_\_\_

RECORDED FOR \_\_\_\_\_

WEBER COUNTY RECORDER

BY: \_\_\_\_\_ DEPUTY

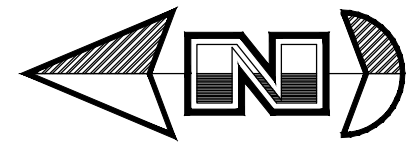

Scale: 1" = 20'

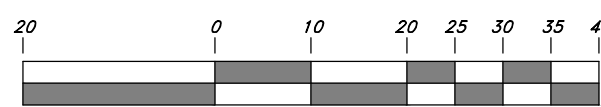

Graphic Scale

### Legend

(Note: All items may not appear on drawing)

- San. Sewer Manhole
- Water Manhole
- Storm Drain Manhole
- Electrical Manhole
- Catch Basins
- Exist. Fire Hydrant
- Fire Hydrant
- Exist. Water Valve
- Water Valve
- Sanitary Sewer
- Culinary Water
- Gas Line
- Irrigation Line
- Storm Drain
- Telephone Line
- Secondary Waterline
- Power Line
- Fire Line
- Land Drain
- Power pole w/guy
- Power pole
- Light Pole
- Fence
- Flowline of ditch
- Overhead Power line
- Corrugated Metal Pipe
- Concrete Pipe
- RCP
- Ductile Iron
- PVC
- Polyvinyl Chloride
- TA
- Top of Asphalt
- EA
- Edge of Asphalt
- CL
- Centerline
- FL
- Flowline
- FF
- Finish Floor
- TC
- Top of Curb
- TW
- Top of Walk
- TCN
- Top of Concrete
- WG
- Natural Ground
- FC
- Finish Grade
- FDC
- Fire Department Connection
- 90-
- Exist. Contour
- Finish Grade
- 55.3374
- 85.27%
- R
- Exist. Grade
- Ridge Line
- Direction of Flow
- Existing Asphalt
- New Asphalt
- Heavy Duty Asphalt
- Concrete
- Open Face
- Curb & Gutter
- Demo Tree

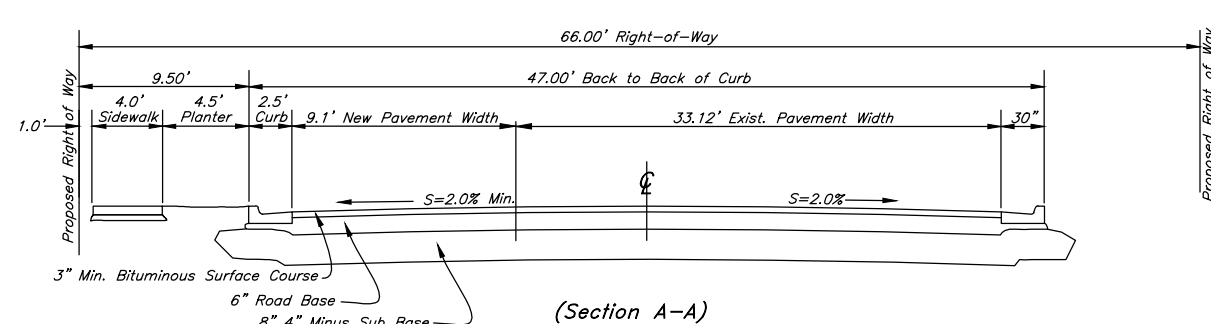
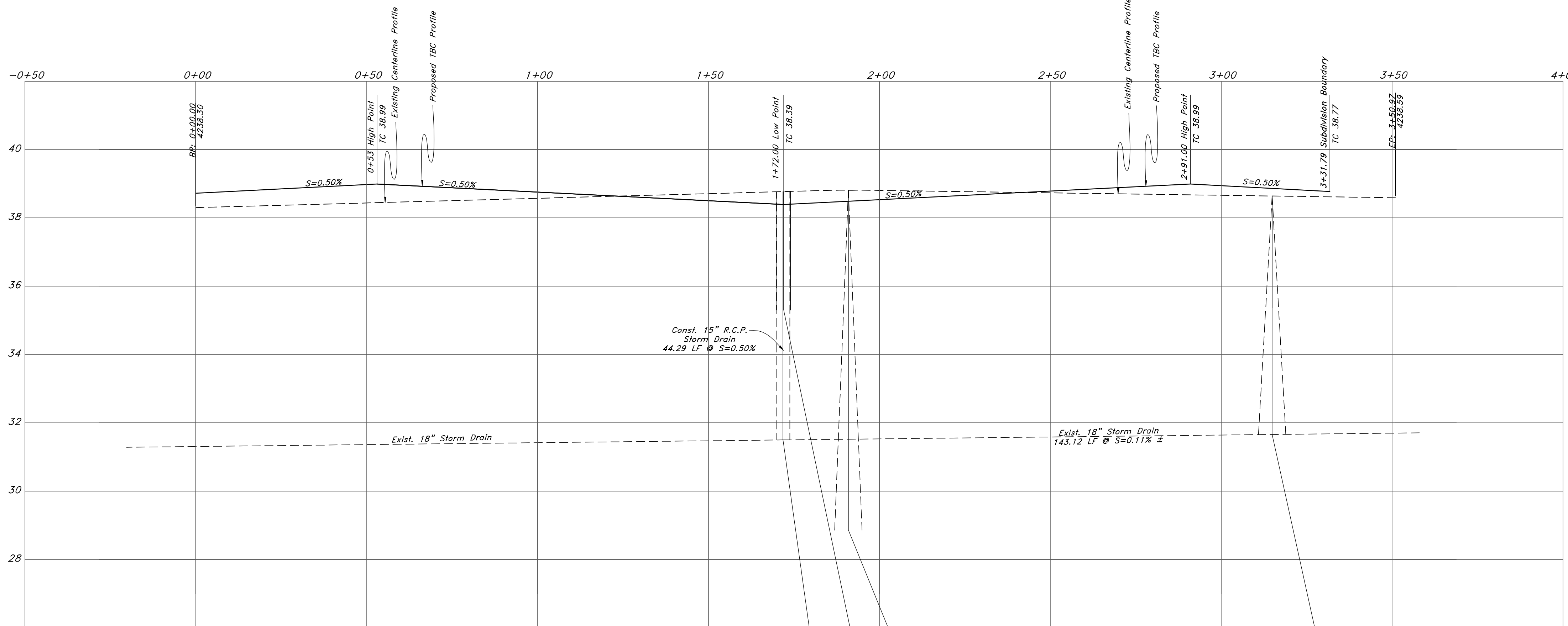
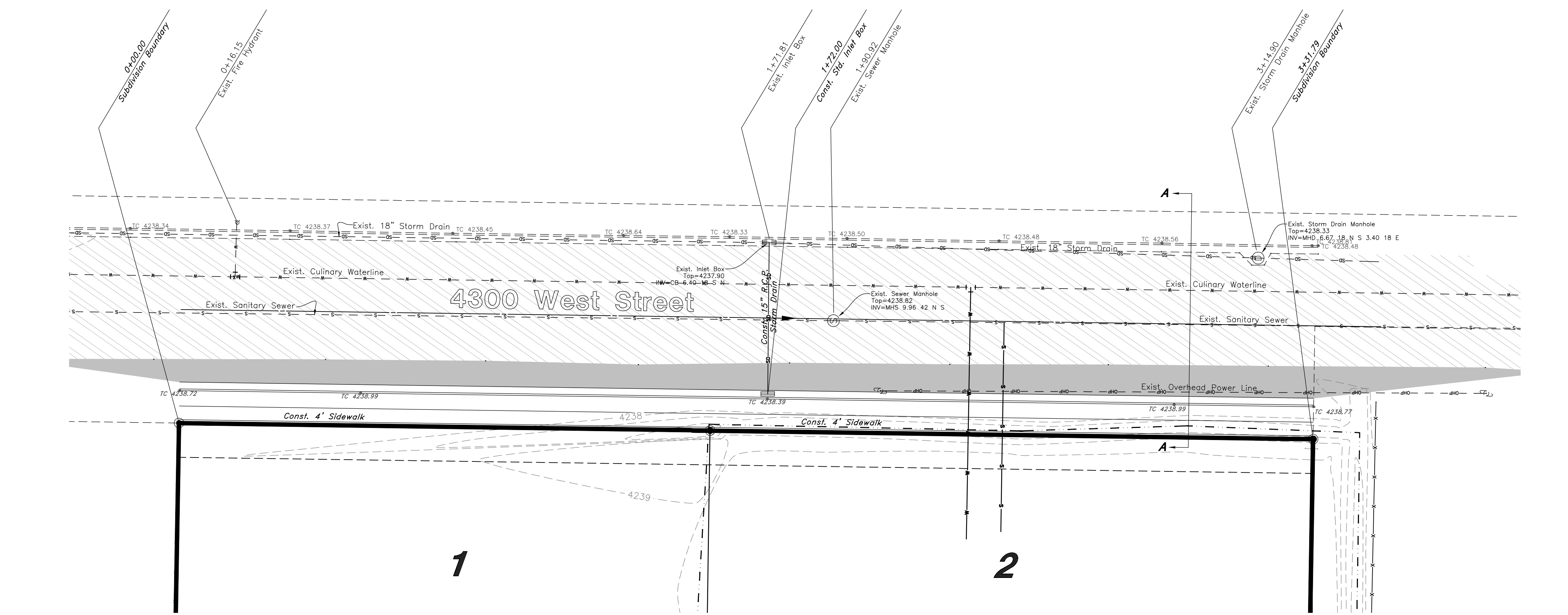

- NOTES**
1. Underground Utility piping materials will meet or exceed Weber County Standards.
  2. Culinary Water services will be 3/4" Dia. Services to be centered on the frontage and Extended 10' beyond the right of way line.
  3. Sanitary Sewer Laterals to be Constructed 10' down slope from the Center of the Lot and Extended 10' beyond the right of way line.
  4. Land Drain Laterals to be Constructed at the Low corner of the Lot and Extended 10' beyond the right of way line.
  5. All Secondary Waterlines are required to have a Minimum of 24" cover.

Note:  
 1. Top back of curb on both sides of road are to be same elevations.  
 2. Bituminous surface course to be constructed in 2 lifts (1-1/2" min. 3" max.)

REV	DATE	DESCRIPTION

**GREAT BASIN ENGINEERING**

5746 SOUTH 1475 EAST OGDEN, UTAH 84403  
 MAIN (801)394-4515 S.L.C. (801)521-0222 FAX (801)392-7544  
 WWW.GRETBASINENGINEERING.COM

**Plan/Profile**

**Hadley Homestead Subdivision**

1861 South 4300 West  
 West Haven City, Ogden County, Utah  
 A part of Section 29, T6N, R2W, SEB&M, U.S. Survey

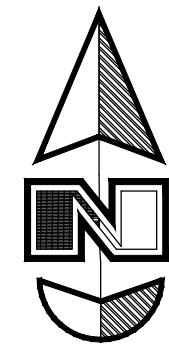

Scale: 1" = 30'

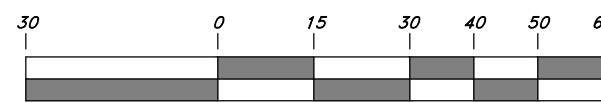

Graphic Scale

### Legend

(Note: All items may not appear on drawing)

- San. Sewer Manhole
- Water Manhole
- Storm Drain Manhole
- Electrical Manhole
- Catch Basins
- Exist. Fire Hydrant
- Fire Hydrant
- Exist. Water Valve
- Water Valve
- Sanitary Sewer
- Culinary Water
- Gas Line
- Irrigation Line
- Storm Drain
- Telephone Line
- Secondary Waterline
- Power Line
- Fire Line
- Land Drain
- Power pole
- Power pole w/guy
- Light Pole
- Fence
- Flowline of ditch
- Overhead Power line
- Corrugated Metal Pipe
- Concrete Pipe
- Reinforced Concrete Pipe
- Ductile Iron
- Polyvinyl Chloride
- Top of Asphalt
- Edge of Asphalt
- Centerline
- Flowline
- Finish Floor
- Top of Curb
- Top of Wall
- Top of Walk
- Top of Concrete
- Natural Ground
- Finish Grade
- Fire Department Connection
- Finish Contour
- Exist. Contour
- Finish Grade
- Exist. Grade
- Ridge Line
- Direction of Flow
- Existing Asphalt
- New Asphalt
- Heavy Duty Asphalt
- Concrete
- Open Face
- Curb & Gutter
- Demo Tree

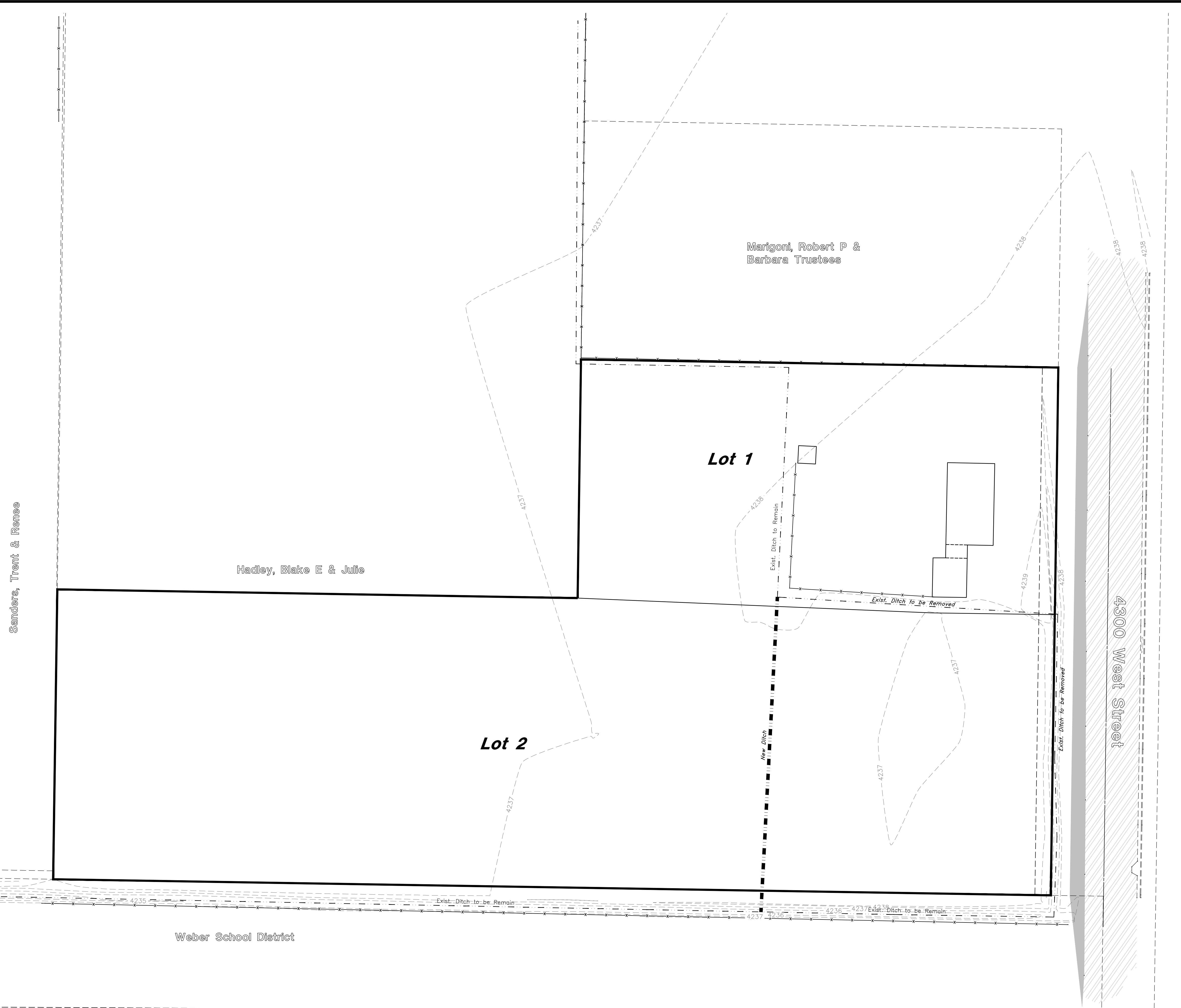

Senders, Trent & Renee

REV	DATE	DESCRIPTION

**GREAT BASIN ENGINEERING**

5746 SOUTH 1475 EAST OGDEN, UTAH 84403  
 MAIN (801)399-4515 S.L.C. (801)521-0222 FAX (801)392-7544  
 WWW.GREATBASINENGINEERING.COM

**Ditch Realignment Plan**  
**Hadley Homestead Subdivision**  
 1861 South 4300 West  
 West Haven City, Ogden County, Utah  
 A part of Section 29, T6N, R2W, SEB&M, U.S. Survey

3 Dec, 2012

SHEET NO.  
**2**

12N744-Hadley