

N 85°47'51" E
N 27°18'12" W

S 89°52'29" E

430.05'

13.98'

S 0°07'09" E

33.97'

31.38'

183.84'

S 85°47'51" W

N 33°34'54" W

26

NOTE: NO PREEXISTING OCCUPATION EXISTS ON THIS PROPERTY

1
A

23

Existing House

S 14°11'40" E

**LOT #26
WOODLAND HILLS**

SWPP GENERAL NOTES

GENERAL CONTRACTOR IS RESPONSIBLE FOR:

ALL STORM WATER AND DIRT WILL BE KEPT ON SITE DURING CONSTRUCTION UNTIL FINAL LANDSCAPING IS DONE. GENERAL CONTRACTOR WILL BE HELD RESPONSIBLE FOR KEEPING DIRT/MUD ON SITE DURING BAD WEATHER AND FOR CLEANING UP AFTER SUBCONTRACTORS

NOTE: STREET CURB AND GUTTER WILL BE INSPECTED AND CLEANED AT THE END OF EVERY DAY.

NOTE: GRAVEL BAGS TO BE PLACED AND MAINTAINED AROUND ANY STORM DRAIN INLET ADJACENT TO OR IMMEDIATELY FROM SITE DURING CONSTRUCTION

NOTE: BERM'S OR SUALES MAY BE REQUIRED ALONG PROPERTY LINES TO PREVENT STORM WATER FLOW ONTO ADJACENT LOTS. FINAL GRADING SHALL BLEND WITH ADJACENT LOTS.

NOTE: A LINED CONCRETE WASHOUT MUST BE PROVIDED AT THE CONSTRUCTION SITE FOR ALL CONCRETE WORK WASHOUT INTO THE FOUNDATION OR ON THE GROUND IS PROHIBITED.

DRAINAGE SWALE

SCALE: 1/2" = 1'-0"

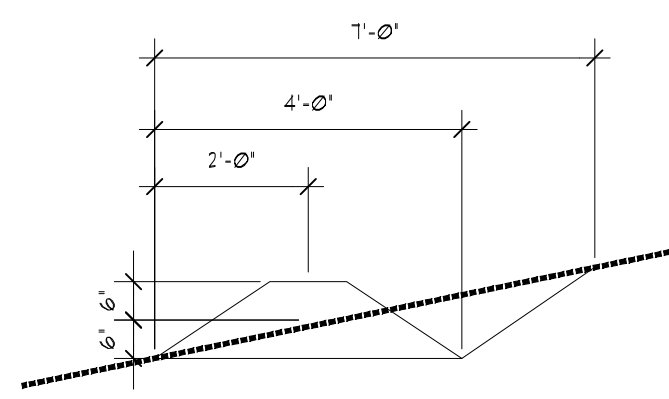

- ① LOCATION OF TRUCK WASH-OFF PROVIDE A 4' GRAVEL BED
 - ② LOCATION OF PORTABLE TOILET INSTALL PER MANUF. INSTRUCTIONS
 - ③ CONSTRUCTION MATERIALS STORAGE AREA
 - ④ CONTAINED DESIGNATED CONCRETE WASHOUT TO BE CLEANED OUT EVERY WEEK
 - ⑤ LOCATION OF DUMPFISTER (FOR CONSTRUCTION DEBRIS)
 - ⑥ PROVIDE A SILT FENCE TO RETAIN STORM WATER RUNOFF AND DEBRIS DURING CONSTRUCTION TO PREVENT NEIGHBORS FROM BEING AFFECTED BY CONSTRUCTION ACTIVITIES
- DISTURBANCE (12321 SF.)
- ⑧ ALL EXCAVATED MATERIAL SHALL BE REMOVED FROM SITE BY TRUCK
 - ⑨ STABILIZED CONSTRUCTION ENTRANCE
 - ⑩ SHALL TO MAINTAIN RAIN AND STORM WATER FOR NATURAL PERCOLATION

$\Delta = 18^{\circ}54'57"$ L = 109.02'
 $R = 330.22'$ LC = 108.52'
 $S = 67^{\circ}01'14"$ W

STORM WATER POLLUTION PREVENTION PLAN

SCALE: 1" = 10'-0"

ATTENTION: THESE PLANS, DRAWINGS, DESIGN, SPECIFICATIONS, OR NOTES SHALL NOT BE REPRODUCED OR COPIED WITHOUT THE WRITTEN CONSENT OF LANDFORMS DESIGN. THESE PLANS ARE RELEASED FOR ONE TIME USE FOR CONSTRUCTION ON THE SITE DESCRIBED. ENGINEER'S DESIGN OF ANY UNLAWFUL USE. STATE: UTAH DATE: 7-16-18

LANDFORMS DESIGN
landforms.com

SWPP PLAN

KEMP RESIDENCE
CUSTOM HOME PLAN

COPYRIGHT 2015 BY LANDFORMS DESIGN (201) 298-2240

REV	DATE	DESCRIPTION	BY
01	10/10/18	GL488 DE	

ENGINEER OF RECORD: C.E.B.
 CAD TECH: M.H.H.
 RELEASE DATE: 9/24/18

S2