



# Land Use Permit

## Weber County Planning Commission

2380 Washington Blvd. STE 240  
Ogden, UT 84401  
Phone: (801) 399-8791 FAX: (801) 399-8862  
webercountyutah.gov/planning

**Permit Number: LUP260-2018**

Permit Type: Structure  
Permit Date: 09/04/2018

### Applicant

**Name:** Hunter Gundersen  
**Business:**  
**Address:**  
, UT  
**Phone:** 801-631-6911

### Owner

**Name:** Ciprian Morar  
**Business:**  
**Address:** CACHE COUNTY - RIDGE NEST LOT 14  
CACHE COUNTY, UT  
**Phone:** 650-380-8261

### Parcel

**Parcel:** 161110014  
**Zoning:** DRR-1 **Area:** 0.13 **Sq Ft:**  
**Address:** Ridge Nest 14 Eden, UT 84310

**Lot(s):** 14 **Subdivision:** Summit Powder Mountain  
**T - R - S - QS:** 7N - 2E - 05 - NW

### Proposal

**Proposed Structure:** SFD  
**Proposed Structure Height:** 28  
**# of Dwelling Units:** 1  
**# Off Street Parking Reqd:** 0

**Building Footprint:** 1204  
**Max Structure Height in Zone:** 35  
**# of Accessory Bldgs:** 0  
**\*Is Structure > 1,000 Sq. Ft?** N/A  
**\*If True Need Certif. Statement**

### Permit Checklist

**Access Type:** Front Lot Line  
**Greater than 4218 ft above sea level?** Yes  
**Additional Setback Reqd. ?** No  
**> 200 ft from paved Road?** No

**Alternative Access File #**  
**Wetlands/Flood Zone?** No  
**Meet Zone Area Frontage?** Yes  
**Hillside Review Reqd?** Yes HSR201803

**Culinary Water District:** Powder Mtn Water/Sewer **Waste Water System:** Powder Mtn Water/Sewer

### Comments

Building footprint must be contained within designated building envelope. Hillside review has been performed (see file HSR 2018-03). Approval conditional upon adherence to all recommendations in any geo reports obtained, as well as hillside review.

# Land Use Permit

## Structure Setback Graphic: New Dwelling, Addition, Etc.

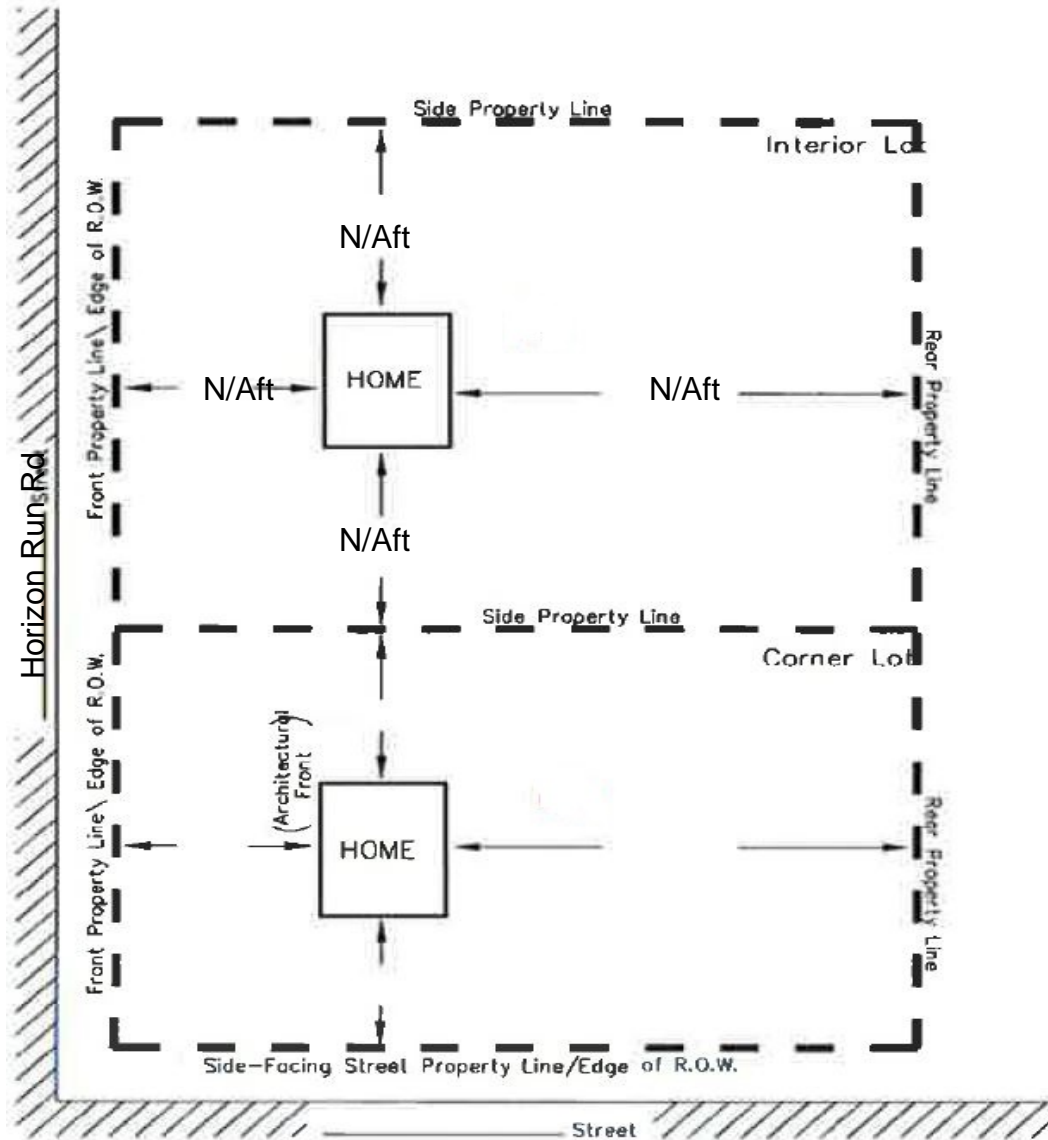

### MINIMUM YARD SETBACKS New Dwelling, Addition, Etc.

#### NOTICE FOR APPLICANT (Please Read Before Signing)

Proposals for the installation of an individual water supply and for a sanitary waste disposal system (septic tank) for any structure designed for human occupation must be approved by Weber County Health Department prior to installation.

Tammy Aydelotte

09/04/2018

Planning Dept. Signature of Approval

Date

I hereby certify that I have read and examined this application and know the same to be true and correct. All provisions of laws and ordinances governing this land use will be complied with whether specified herein or not. I make this statement under penalty of perjury.

Contractor/Owner Signature of Approval

Date