



Land Use Permit

Weber County Planning Commission

2380 Washington Blvd. STE 240

Ogden, UT 84401

Phone: (801) 399-8791 FAX: (801) 399-8862

webercountyutah.gov/planning

Permit Number: LUP260-2018

Permit Type: Structure

Permit Date: 09/04/2018

Applicant

Name: Hunter Gundersen

Business:

Address:

, UT

Phone: 801-631-6911

Owner

Name: Ciprian Morar

Business:

Address: 7719 E Horizon Run

Eden, UT 84310

Phone: 650-380-8261

Parcel

Proposal

Proposed Structure: SFD

Proposed Structure Height: 28

of Dwelling Units:

Off Street Parking Reqd:

Building Footprint: 1204

Max Structure Height in Zone: 35

of Accessory Bldgs:

***Is Structure > 1,000 Sq. Ft?** N/A

*If True Need Certif. Statement

Permit Checklist

Access Type: Front Lot Line

Greater than 4218 ft above sea level? Yes

Additional Setback Reqd. ? No

> 200 ft from paved Road? No

Culinary Water District: Powder Mtn Water/Sewer

Alternative Access File #

Wetlands/Flood Zone? No

Meet Zone Area Frontage? Yes

Hillside Review Reqd? Yes HSR201803

Waste Water System: Powder Mtn Water/Sewer

Comments

Building footprint must be contained within designated building envelope. Hillside review has been performed (see file HSR 2018-03). Approval conditional upon adherence to all recommendations in any geo reports obtained, as well as hillside review.

Land Use Permit

Structure Setback Graphic: New Dwelling, Addition, Etc.

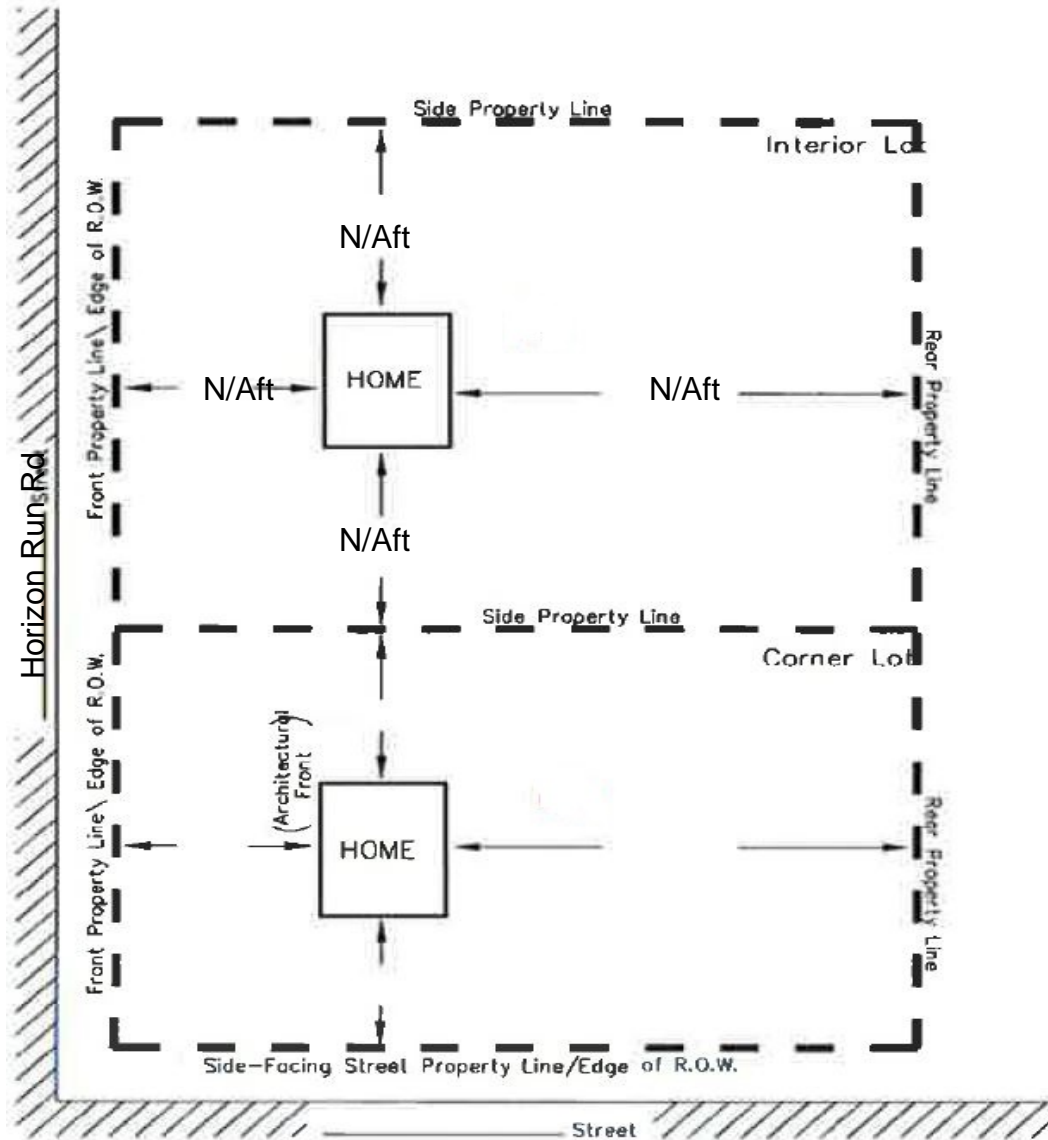

MINIMUM YARD SETBACKS New Dwelling, Addition, Etc.

NOTICE FOR APPLICANT (Please Read Before Signing)

Proposals for the installation of an individual water supply and for a sanitary waste disposal system (septic tank) for any structure designed for human occupation must be approved by Weber County Health Department prior to installation.

09/04/2018

Planning Dept. Signature of Approval

Date

I hereby certify that I have read and examined this application and know the same to be true and correct. All provisions of laws and ordinances governing this land use will be complied with whether specified herein or not. I make this statement under penalty of perjury.

Contractor/Owner Signature of Approval

Date