

Common Plan SWPPP for Yost Residence

5365 E Lallybroch Lane

Eden, UT 84310

Lyle & Elizabeth Yost

1431 Ridge Topway

Clearwater, FL 33765

Jeff Scadden

801-814-2323

Date

2/8/2018



1. Project Information

Project Name: Yost Residence

Address: 5365 E Lallybroch Lane

City: Eden

State: UT

Zip: 84310

Latitude: 41°19'57.23"N

Longitude: 111°49'01.43"W

UPDES Permit Tracking Number:

Owner: Lyle & Elisabeth Yost

Contact Person: Lyle Yost

Address: 1431 Ridge Top Way

City: Clearwater

State: FL

Zip: 33765

Telephone Number:

Email Address:

General Contractor:

Contact Person: Jeff Scadden

Address:

City:

State:

Zip:

Telephone Number: 801-814-2323

Email Address:

1.5

Unknown Features

Discovery of Historical, Archaeological or Paleontological Objects, Features, Sites, or Human Remains

- A. Immediately suspend construction operations in the vicinity (100 foot minimum buffer) of the discovery.
- B. Verbally notify the Public Works Department and provide them the exact location.
- C. Protect the discovery and provide written confirmation of the discovery to the City and State Historic Departments within two calendar days.
- D. Contractor and City follow State mitigation laws.

2. Best Management Practices

2.1 SWPPP Sign (see permit part 1.10, 4.2.11)

Description of construction board is filed in Appendix K.

2.2 Sensitive Features Control (see permit part 2.2)

2.2.1 Wetlands

There are no wetlands within or near the proposed site.

2.2.2 Water Bodies within or 30' from Disturbance Boundary (see permit part 2.3.5)

There are no bodies of water within 30' of the disturbance boundary.

2.3 Sediment Control (see permit part 2.1.2, 2.1.3 & 2.3)

2.3.1 Trap/Filter Sediment at Property Boundary (see permit part 2.1.2)

Silt Fence (BMP C233)

BMP description, rationale for use and specifications, and details are filed in Appendix K.

2.4.1 Inlet Protection (see permit part 2.1.3 & 2.3)

Storm Drain Inlet Protection (BMP C220)

BMP description, rationale for use and specifications, and details are filed in Appendix K.

2.4.1 Steep Slopes (see permit part 2.3.2)

Straw Wattles (BMP C254)

BMP description, rationale for use and specifications, and details are filed in Appendix K.

2.4.2 Street Maintenance (see permit part 3.2.2)

Manual Sweeping

BMP description, rationale for use and specifications, and details are filed in Appendix K.

2.4 Top Soil Preservation (see permit part 2.5)

Preserve Existing Vegetation (BMP C101)

BMP description, rationale for use and specifications, and details are filed in Appendix K.

2.5 Dust Control (see permit part)

2.5.1

Dust Control (BMP C140)

BMP description, rationale for use and specifications, and details are filed in Appendix K.

2.6 Egress Control (see permit part 2.4)

2.6.1 Track Out (see permit part 2.4.1)

Stabilized Construction Entrance (BMP C105)

BMP description, rationale for use and specifications, and details are filed in Appendix K.

Wheel Wash (BMP C106)

BMP description, rationale for use and specifications, and details are filed in Appendix K.

2.7 Waste Management Control (see permit part 4.2.6)

2.7.1 Solid Waste (see permit part 2.4.3)

Waste Policies

BMP description, rationale for use and specifications, and details are filed in Appendix K.

2.7.2 Construction Spoil (see permit part 2.1.1)

Stabilized Construction Entrance (BMP C105)

BMP description, rationale for use and specifications, and details are filed in Appendix K.

Wheel Wash (BMP C106)

BMP description, rationale for use and specifications, and details are filed in Appendix K.

2.7.3 Sanitary Waste (see permit part 2.4.4)

Portable Toilets (BMP C190)

BMP description, rationale for use and specifications, and details are filed in Appendix K.

2.7.4 Cement Product Operations (see permit part 2.4.5, 2.9.2)

Concrete Waste Management (BMP C151)

BMP description, rationale for use and specifications, and details are filed in Appendix K.

2.7.5 Concrete Cutting Operations(see permit part 2.9.2)

Concrete Waste Management (BMP C151)

BMP description, rationale for use and specifications, and details are filed in Appendix K.

2.7.6 Non Aqueous Waste(see permit part 2.8.2)

Material Delivery, Storage and Containment (BMP C153)

BMP description, rationale for use and specifications, and details are filed in Appendix K.

2.7.7 Construction Wastewater(see permit part 2.7, 2.9, 2.9.4)

Vehicle Equipment Fueling/Cleaning (BMP C155)

BMP description, rationale for use and specifications, and details are filed in Appendix K.

2.8 Management of Construction Materials Control

2.8.1 Storage of Construction Materials(see permit part 2.8.2)

Spill Control Plan

BMP description, rationale for use and specifications, and details are filed in Appendix K.

2.8.2 Construction Staging (backfill) (see permit part 2.1.1)

Material Delivery, Storage and Containment (BMP C153)

BMP description, rationale for use and specifications, and details are filed in Appendix K.

2.8.3 Construction Staging (Landscaping) *(see permit part 2.1.1)*

Material Delivery, Storage and Containment (BMP C153)

BMP description, rationale for use and specifications, and details are filed in Appendix K.

2.9 Final Stabilization *(see permit part 2.6)*

2.9.1 Landscaping Plan

Landscaping and final stabilization will be done per the landscaping design.

2.9.2 Temporary Containment of Sediment

Silt Fence (BMP C233)

BMP description, rationale for use and specifications, and details are filed in Appendix K.

3. Spill Prevention and Response Plan (see permit part 2.8.3, 2.9.3)

Description of Spill control Plan, details and policy are filed in Appendix K.

Any discharges in 24 hours equal to or in excess of the reportable quantities listed in 40 CFR 117, 40 CFR 110, and 40 CFR 302 will be reported to the National Response Center and the Division of Water Quality (DWQ) as soon as practical after knowledge of the spill is known to the permittee. The permittee shall submit within 14 calendar days of knowledge of the release a written description of: the release (including the type and estimate of the amount of material released), the date that such release occurred, the circumstances leading to the release, and measures taken and/or planned to be taken to the Division of Water Quality (DWQ), 288 North 1460 West, P.O. Box 144870, Salt Lake City, Utah 84114-4870. The Storm Water Pollution Prevention Plan must be modified within 14 calendar days of knowledge of the release to provide a description of the release, the circumstances leading to the release, and the date of the release. In addition, the plan must be reviewed to identify measures to prevent the reoccurrence of such releases and to respond to such releases, and the plan must be modified where appropriate.

Agency	Phone Number
National Response Center	(800) 424-8802
Division of Water Quality (DWQ) 24-Hr Reporting	(801) 538-6146; (801) 536-4123
Utah Department of Health Emergency Response	(801) 580-6681
UFA	911

Minimum spill quantities requiring reporting:

Material	Media Released To	Reportable Quantity
Engine oil, fuel, hydraulic & brake fluid	Land	25 gallons
Paints, solvents, thinners	Land	100 lbs (13 gallons)
Engine oil, fuel, hydraulic & brake fluid	Water	Visible Sheen
Refrigerant	Air	1 lb
Antifreeze, battery acid, gasoline, engine degreasers	Air, Land, Water	100 lbs (13 gallons)

Emphasis to:

- 1st Priority: Protect all people (including onsite staff)
- 2nd Priority: Protect equipment and property
- 3rd Priority: Protect the environment

1. Make sure the spill area is safe to enter and that it does not pose an immediate threat to health or safety of any person.
2. Check for hazards (flammable material, noxious fumes, cause of spill) – if flammable liquid, turn off engines and nearby electrical equipment. If serious hazards are present leave area and call 911. LARGE SPILLS ARE LIKELY TO PRESENT A HAZARD.

3. Stop the spill source and contain flowing spills immediately with spill kits, dirt or other material that will achieve containment.
4. Call co-workers and supervisor for assistance and to make them aware of the spill and potential dangers
5. If spilled material has entered a storm sewer, regardless of containment; contact the Municipal Storm Water Division.
6. Cleanup all spills (flowing or non-flowing) immediately following containment. Clean up spilled material according to manufacturer specifications, for liquid spills use absorbent materials AND DO NOT FLUSH AREA WITH WATER.
7. Properly dispose of cleaning materials and used absorbent material according to manufacturer specifications.
8. Report the reportable quantity to the Municipal Storm Water Division.

Emergency Numbers

Utah Hazmat Response Officer 24 hrs	(801)-538-3745
Weber County Sheriff's Office	(801)-778-6602
Weber Fire District	(801)-782-3580
Weber County Storm Water Division	(801)-399-8374

4. Site Map(s) *(see permit part 4.2.3)*

The SWPPP site map is filed in Appendix B

5. Record Keeping

See the appendices in Appendix A-K.

SWPPP Inspections-Maintenance-Correction Report (permit part 3.2.1, 3.2.2, 3.3, 3.4, 4.2.12)

Inspections are required every 7 calendar days

Repair or replace BMPs prior to need or by end of week whichever comes first. Update the Inspection-Maintenance-Correction Report weekly.

Section 3.2.2 requires daily maintenance of pavements and site grounds.

See the Inspection-Maintenance-Correction Reports in Appendix E

Changes to the SWPPP (see permit part 4.2.12, 4.2.13)

See the Amendment Log in Appendix F.

Training(see permit part 4.2.7)

Training Logs and Documents are filed in Appendix H.

6. Discharge Information

Receiving Waters

1. Pine View Reservoir

Impaired Waters

Impaired Surface Water	Is this surface water impaired? X Yes <input type="checkbox"/> No	Pollutant(s) causing the impairment	Has a TMDL been completed? X Yes <input type="checkbox"/> No	Pollutant(s) for which there is a TMDL
Pine View Reservoir	X Yes <input type="checkbox"/> No	Dissolved Oxygen; total phosphorus	X Yes <input type="checkbox"/> No	Dissolved Oxygen; total phosphorus

7. Certification, Notification and Delegation (see permit part 4.2.9)

Owner Certification: See documents filed in Appendix G.

Operator Certification: See documents filed in Appendix G.

Delegation of Authority: See documents filed in Appendix G.

Subcontractor Certification: See documents filed in Appendix G.

Notice of Permit Transfer Requirements: See documents filed in Appendix G.

SWPPP Appendices

Appendix A: General Location Map

Appendix B: SWPPP Site Maps

Appendix C: UPDES Permit(UTRH00000)

Appendix D: Permits; NOI, MS4

Appendix E: Inspection-Maintenance-Correction Report

Appendix F: SWPPP Amendment Log

Appendix G: Certifications, Agreements, Delegation of Authority

Appendix H: Training Log

Appendix I: Construction Plans

Appendix J: Additional Information

Appendix K: BMP Specifications and Details

Appendix A
General Location / Site Maps

Yost Residence Location Map

Write a description for your map.

Legend

Yost Residence
Location



Appendix B
SWPPP Site Maps



- A Utah Corporation -
ENGINEERS
SURVEYORS
PLANNERS

3302 N. Main Street
 Spanish Fork, UT 84660
 Phone: 801.798.0555
 Fax: 801.798.9393
 office@lei-eng.com
 www.lei-eng.com

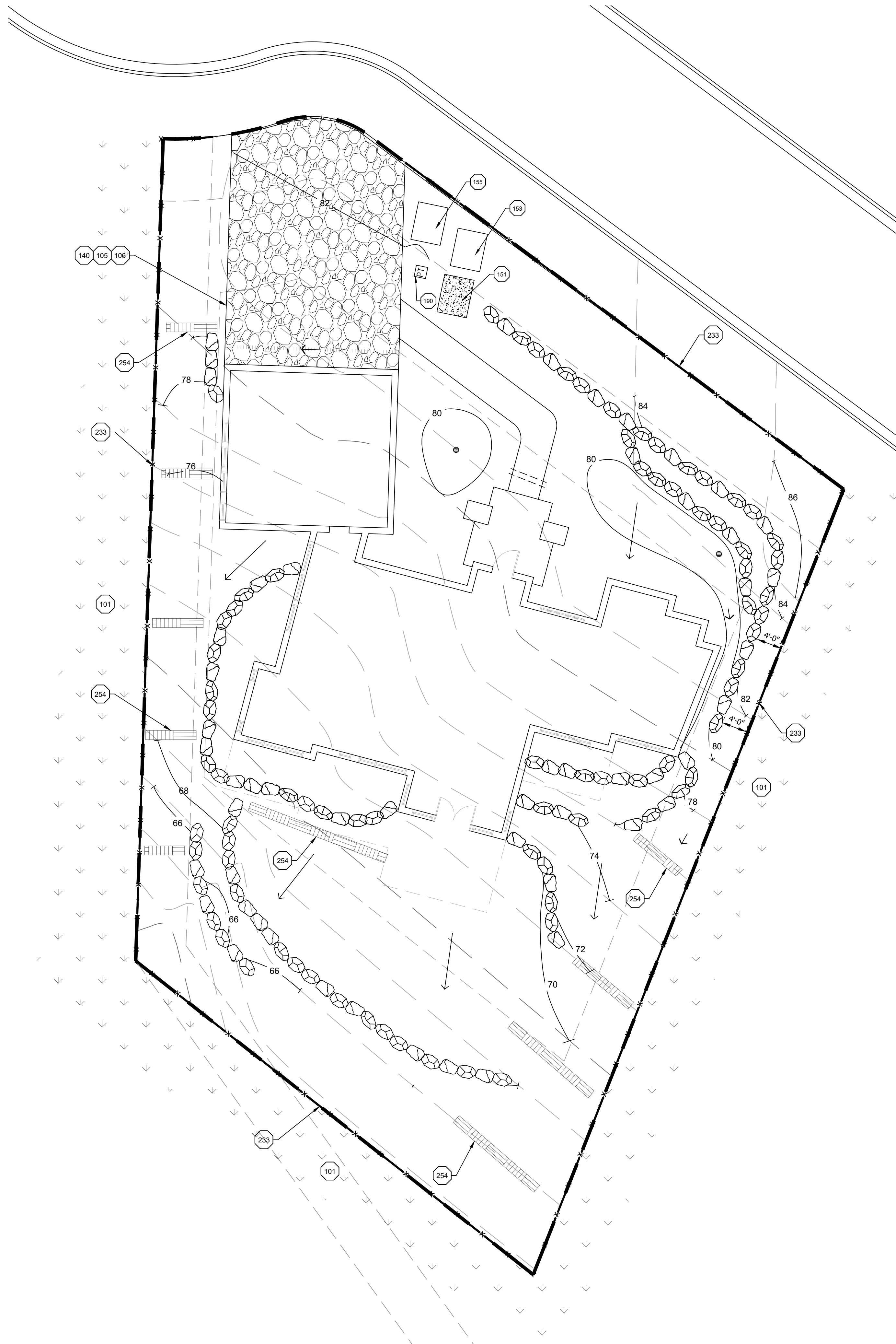
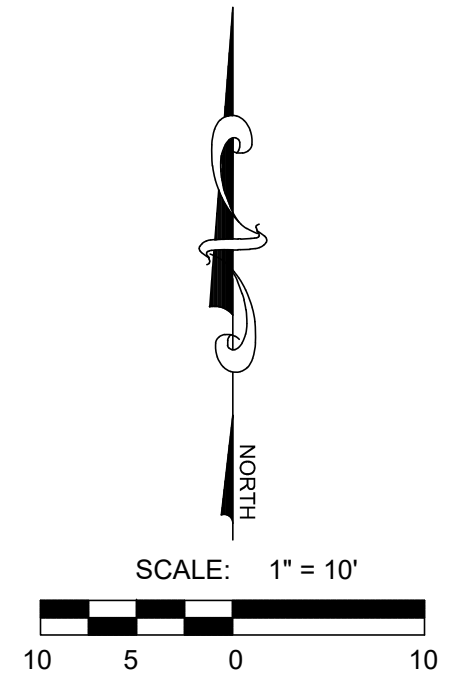

PRESERVATION OF EXISTING VEGETATION

- CLEARLY MARK, FLAG OR FENCE VEGETATION OR AREAS WHERE VEGETATION SHOULD BE PRESERVED.
- PREPARE LANDSCAPING PLANS WHICH INCLUDE AS MUCH EXISTING VEGETATION AS POSSIBLE AND STATE PROPER CARE DURING AND AFTER CONSTRUCTION.
- DEFINE AND PROTECT WITH BERMS, FENCING, SIGNS, ETC. A SETBACK AREA FROM VEGETATION TO BE PRESERVED.
- PROPOSE LANDSCAPE PLANS WHICH DO NOT INCLUDE PLANT SPECIES THAT COMPETE WITH EXISTING VEGETATION.
- DO NOT LOCATE CONSTRUCTION TRAFFIC ROUTES, SPOIL PILES, ETC. WHERE SIGNIFICANT ADVERSE IMPACT ON EXISTING VEGETATION MAY OCCUR.

NOTES

1. REFER TO SWPPP BINDER FOR DETAILS OF BMP'S.
2. CONTRACTOR TO ADD ADDITIONAL BMP'S AS NECESSARY BASED ON SITE CONDITIONS.
3. EXISTING AND PROPOSED GRADING AS SHOWN ON THIS PLAN WAS PROVIDED BY OTHERS. ANY DESIGN ISSUES SHALL BE ADDRESSED WITH SITE DESIGNERS.
4. REFER TO CONSTRUCTION DRAWINGS FOR FULL GRADING DESIGN.
5. INLET PROTECTION SHALL BE INSTALLED ON ANY INLETS LOCATED WITHIN 100' DOWNSTREAM OF PROJECT.

LEGEND

	PROPERTY LINE
	SILT FENCE / LIMITS OF DISTURBANCE
	CONCRETE WASTE MGMT.
	STABILIZED CONSTRUCTION ENTRANCE
	PRESERVE EXISTING VEGETATION
	STRAW WATTLES
	PORTABLE TOILETS
	FLOW ARROW
	PROPOSED RETAINING WALL

CONSTRUCTION PHASE STORM WATER POLLUTION PROTECTION PLAN BEST MANAGEMENT PRACTICES (BMP)				
BMP#	BMP SYMBOL	TITLE	LOCATION	DURATION
C101	101	PRESERVING NATURAL VEGETATION	AS SHOWN	COMMENCEMENT OF GRADING THROUGH COMPLETION OF SITE IMPROVEMENTS
C103	103	PLASTIC OR METAL FENCE	AS SHOWN	COMMENCEMENT OF GRADING THROUGH COMPLETION OF SITE IMPROVEMENTS
C105	105	STABILIZED CONSTRUCTION ENTRANCE	AS SHOWN	BEGINNING OF CONSTRUCTION THROUGH COMPLETION OF SITE IMPROVEMENTS
C106	106	WHEEL WASH	AS NECESSARY	BEGINNING OF CONSTRUCTION THROUGH COMPLETION OF SITE IMPROVEMENTS
C190	190	PORTABLE TOILETS	AS SHOWN	BEGINNING OF CONSTRUCTION THROUGH COMPLETION OF SITE IMPROVEMENTS
C140	140	DUST CONTROL	PER CONTRACTOR	BEGINNING OF CONSTRUCTION THROUGH COMPLETION OF SITE IMPROVEMENTS
C151	151	CONCRETE WASTE MANAGEMENT	PER CONTRACTOR / AS SHOWN	BEGINNING OF CONSTRUCTION THROUGH COMPLETION OF SITE IMPROVEMENTS
C220	220	STORM DRAIN INLET PROTECTION	AS SHOWN	COMMENCEMENT OF GRADING THROUGH COMPLETION OF SITE IMPROVEMENTS
C233	233	SILT FENCE	PER CONTRACTOR/ AS SHOWN	COMMENCEMENT OF GRADING THROUGH COMPLETION OF SITE IMPROVEMENTS
C233	254	STRAW WATTLE	PER CONTRACTOR/ AS SHOWN	COMMENCEMENT OF GRADING THROUGH COMPLETION OF SITE IMPROVEMENTS
C153	153	MATERIAL DELIVERY, STORAGE & CONTAINMENT	PER CONTRACTOR/ AS SHOWN	COMMENCEMENT OF GRADING THROUGH COMPLETION OF SITE IMPROVEMENTS
C155	155	VEHICLE EQUIPMENT FUELING/CLEANING	PER CONTRACTOR/ AS SHOWN	COMMENCEMENT OF GRADING THROUGH COMPLETION OF SITE IMPROVEMENTS

NOT FOR CONSTRUCTION

YOST RESIDENCE
 EDEN, UTAH
 APPENDIX "B"
 EROSION CONTROL PLAN

REVISIONS
1 -
2 -
3 -
4 -
5 -

LEI PROJECT #:
2018-008
 DRAWN BY:
MJV
 DESIGNED BY:
BCT
 SCALE:
1" = 10'
 DATE:
02/12/2018

SHEET
EC-1

U:_PROJECTS\2018\2018-008-EDEN\2018-008-YOST-SWPPP.DWG 2/12/2018 8:10 AM

Appendix C
UPDES Permit (UTRH00000)

Appendix D

Permits; NOI, MS4 (Including City, County, State, 3rd Party; MS4 Acknowledgement)

Appendix E
Inspection-Maintenance-Correction Report

Stormwater Construction Site Inspection Report

General Information			
Project Name			
NPDES Tracking No.		Location	
Date of Inspection		Start/End Time	
Inspector's Name(s)			
Inspector's Title(s)			
Inspector's Contact Information			
Inspector's Qualifications			
Describe present phase of construction			
Type of Inspection:			
<input type="checkbox"/> Regular <input type="checkbox"/> Pre-storm event <input type="checkbox"/> During storm event <input type="checkbox"/> Post-storm event			
Weather Information			
Has there been a storm event since the last inspection? <input type="checkbox"/> Yes <input type="checkbox"/> No			
If yes, provide:			
Storm Start Date & Time:	Storm Duration (hrs):	Approximate Amount of Precipitation (in):	
Weather at time of this inspection?			
<input type="checkbox"/> Clear <input type="checkbox"/> Cloudy <input type="checkbox"/> Rain <input type="checkbox"/> Sleet <input type="checkbox"/> Fog <input type="checkbox"/> Snowing <input type="checkbox"/> High Winds			
<input type="checkbox"/> Other: _____			
Temperature: _____			
Have any discharges occurred since the last inspection? <input type="checkbox"/> Yes <input type="checkbox"/> No			
If yes, describe:			
Are there any discharges at the time of inspection? <input type="checkbox"/> Yes <input type="checkbox"/> No			
If yes, describe:			

Site-specific BMPs

- Number the structural and non-structural BMPs identified in your SWPPP on your site map and list them below (add as many BMPs as necessary). Carry a copy of the numbered site map with you during your inspections. This list will ensure that you are inspecting all required BMPs at your site.
- Describe corrective actions initiated, date completed, and note the person that completed the work in the Corrective Action Log.

	BMP	BMP Installed?	BMP Maintenance Required?	Corrective Action Needed and Notes
1		<input type="checkbox"/> Yes <input type="checkbox"/> No	<input type="checkbox"/> Yes <input type="checkbox"/> No	
2		<input type="checkbox"/> Yes <input type="checkbox"/> No	<input type="checkbox"/> Yes <input type="checkbox"/> No	
3		<input type="checkbox"/> Yes <input type="checkbox"/> No	<input type="checkbox"/> Yes <input type="checkbox"/> No	
4		<input type="checkbox"/> Yes <input type="checkbox"/> No	<input type="checkbox"/> Yes <input type="checkbox"/> No	
5		<input type="checkbox"/> Yes <input type="checkbox"/> No	<input type="checkbox"/> Yes <input type="checkbox"/> No	
6		<input type="checkbox"/> Yes <input type="checkbox"/> No	<input type="checkbox"/> Yes <input type="checkbox"/> No	
7		<input type="checkbox"/> Yes <input type="checkbox"/> No	<input type="checkbox"/> Yes <input type="checkbox"/> No	
8		<input type="checkbox"/> Yes <input type="checkbox"/> No	<input type="checkbox"/> Yes <input type="checkbox"/> No	
9		<input type="checkbox"/> Yes <input type="checkbox"/> No	<input type="checkbox"/> Yes <input type="checkbox"/> No	
10		<input type="checkbox"/> Yes <input type="checkbox"/> No	<input type="checkbox"/> Yes <input type="checkbox"/> No	
11		<input type="checkbox"/> Yes <input type="checkbox"/> No	<input type="checkbox"/> Yes <input type="checkbox"/> No	
12		<input type="checkbox"/> Yes <input type="checkbox"/> No	<input type="checkbox"/> Yes <input type="checkbox"/> No	
13		<input type="checkbox"/> Yes <input type="checkbox"/> No	<input type="checkbox"/> Yes <input type="checkbox"/> No	
14		<input type="checkbox"/> Yes <input type="checkbox"/> No	<input type="checkbox"/> Yes <input type="checkbox"/> No	
15		<input type="checkbox"/> Yes <input type="checkbox"/> No	<input type="checkbox"/> Yes <input type="checkbox"/> No	
16		<input type="checkbox"/> Yes <input type="checkbox"/> No	<input type="checkbox"/> Yes <input type="checkbox"/> No	
17		<input type="checkbox"/> Yes <input type="checkbox"/> No	<input type="checkbox"/> Yes <input type="checkbox"/> No	
18		<input type="checkbox"/> Yes <input type="checkbox"/> No	<input type="checkbox"/> Yes <input type="checkbox"/> No	
19		<input type="checkbox"/> Yes <input type="checkbox"/> No	<input type="checkbox"/> Yes <input type="checkbox"/> No	
20		<input type="checkbox"/> Yes <input type="checkbox"/> No	<input type="checkbox"/> Yes <input type="checkbox"/> No	

Overall Site Issues

Below are some general site issues that should be assessed during inspections. Customize this list as needed for conditions at your site.

	BMP/activity	Implemented?	Maintenance Required?	Corrective Action Needed and Notes
1	Are all slopes and disturbed areas not actively being worked properly stabilized?	<input type="checkbox"/> Yes <input type="checkbox"/> No	<input type="checkbox"/> Yes <input type="checkbox"/> No	

Stormwater Pollution Prevention Plan (SWPPP) February, 2018
Yost Residence

	BMP/activity	Implemented?	Maintenance Required?	Corrective Action Needed and Notes
2	Are natural resource areas (e.g., streams, wetlands, mature trees, etc.) protected with barriers or similar BMPs?	<input type="checkbox"/> Yes <input type="checkbox"/> No	<input type="checkbox"/> Yes <input type="checkbox"/> No	
3	Are perimeter controls and sediment barriers adequately installed (keyed into substrate) and maintained?	<input type="checkbox"/> Yes <input type="checkbox"/> No	<input type="checkbox"/> Yes <input type="checkbox"/> No	
4	Are discharge points and receiving waters free of any sediment deposits?	<input type="checkbox"/> Yes <input type="checkbox"/> No	<input type="checkbox"/> Yes <input type="checkbox"/> No	
5	Are storm drain inlets properly protected?	<input type="checkbox"/> Yes <input type="checkbox"/> No	<input type="checkbox"/> Yes <input type="checkbox"/> No	
6	Is the construction exit preventing sediment from being tracked into the street?	<input type="checkbox"/> Yes <input type="checkbox"/> No	<input type="checkbox"/> Yes <input type="checkbox"/> No	
7	Is trash/litter from work areas collected and placed in covered dumpsters?	<input type="checkbox"/> Yes <input type="checkbox"/> No	<input type="checkbox"/> Yes <input type="checkbox"/> No	
8	Are washout facilities (e.g., paint, stucco, concrete) available, clearly marked, and maintained?	<input type="checkbox"/> Yes <input type="checkbox"/> No	<input type="checkbox"/> Yes <input type="checkbox"/> No	
9	Are vehicle and equipment fueling, cleaning, and maintenance areas free of spills, leaks, or any other deleterious material?	<input type="checkbox"/> Yes <input type="checkbox"/> No	<input type="checkbox"/> Yes <input type="checkbox"/> No	
10	Are materials that are potential stormwater contaminants stored inside or under cover?	<input type="checkbox"/> Yes <input type="checkbox"/> No	<input type="checkbox"/> Yes <input type="checkbox"/> No	
11	Are non-stormwater discharges (e.g., wash water, dewatering) properly controlled?	<input type="checkbox"/> Yes <input type="checkbox"/> No	<input type="checkbox"/> Yes <input type="checkbox"/> No	

	BMP/activity	Implemented?	Maintenance Required?	Corrective Action Needed and Notes
12	Visually inspect all discharges. Are all discharges approved as per the requirements set forth in this report?	<input type="checkbox"/> Yes <input type="checkbox"/> No	<input type="checkbox"/> Yes <input type="checkbox"/> No	
13	(Other)	<input type="checkbox"/> Yes <input type="checkbox"/> No	<input type="checkbox"/> Yes <input type="checkbox"/> No	

Non-Compliance

Describe any incidents of non-compliance not described above:

CERTIFICATION STATEMENT

“I certify under penalty of law that this document and all attachments were prepared under my direction or supervision in accordance with a system designed to assure that qualified personnel properly gathered and evaluated the information submitted. Based on my inquiry of the person or persons who manage the system, or those persons directly responsible for gathering the information, the information submitted is, to the best of my knowledge and belief, true, accurate, and complete. I am aware that there are significant penalties for submitting false information, including the possibility of fine and imprisonment for knowing violations.”

Print name and title: _____

Signature: _____ **Date:** _____

Appendix F
SWPPP Amendment Log

Appendix G
Certifications, Agreements, Delegation of Authority

Appendix G –Subcontractor Certifications/Agreements

SUBCONTRACTOR CERTIFICATION
STORMWATER POLLUTION PREVENTION PLAN

Project Number: _____

Project Title: _____

Operator(s): _____

As a subcontractor, you are required to comply with the Stormwater Pollution Prevention Plan (SWPPP) for any work that you perform on-site. Any person or group who violates any condition of the SWPPP may be subject to substantial penalties or loss of contract. You are encouraged to advise each of your employees working on this project of the requirements of the SWPPP. A copy of the SWPPP is available for your review at the office trailer.

Each subcontractor engaged in activities at the construction site that could impact stormwater must be identified and sign the following certification statement:

I certify under the penalty of law that I have read and understand the terms and conditions of the SWPPP for the above designated project and agree to follow the BMPs and practices described in the SWPPP.

This certification is hereby signed in reference to the above named project:

Company: _____

Address: _____

Telephone Number: _____

Type of construction service to be provided: _____

Signature: _____

Title: _____

Date: _____

Appendix H
Training Log

Appendix H –SWPPP Training Log

Stormwater Pollution Prevention Training Log

Project Name: _____

Project Location: _____

Instructor's Name(s): _____

Instructor's Title(s): _____

Course Location: _____ Date: _____

Course Length (hours): _____

Stormwater Training Topic: *(check as appropriate)*

- Erosion Control BMPs Emergency Procedures
 Sediment Control BMPs Good Housekeeping BMPs
 Non-Stormwater BMPs

Specific Training Objective: _____

Attendee Roster: *(attach additional pages as necessary)*

No.	Name of Attendee	Company
1		
2		
3		
4		
5		
6		
7		
8		

Appendix I
Construction Plans

Appendix J
Additional Information

Appendix K
BMP Specifications and Details

2.1 SWPPP Sign

Operations or Site Condition: NA

Instruction: See site plan for location

Installation Schedule: Prior to any land disturbance

Maintenance Requirements: Repair when damaged

Maintenance Personnel: Jeff Scadden: 801-814-2323

Applicable Trades: NA

Detail:

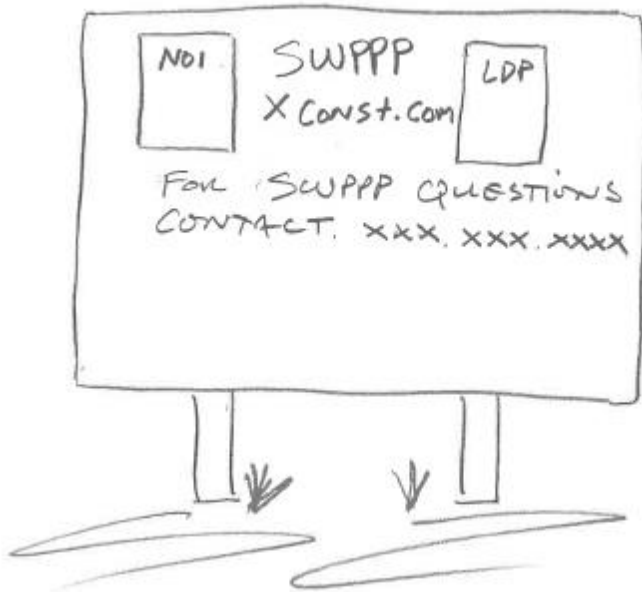

2.4.2 Manual Sweeping

Operation and Site Conditions: Some operations require driving off durable surfaces and the track out or boundary controls can fail which will necessitate cleaning of the streets and gutters.

Instruction: Square nose shovel and broom. All trades are expected to remove tracked out or mud and dirt that end up on street from regular operations. Repeat removal until no more mud can be picked up. Do not worry about the dirt stain and do not wash with water. The small amounts of mud trapped in the tread will also spread dirt on the streets overtime. In this case the mud will be removed by BMP 2.3.3.

Schedule: NA.

Maintenance: Immediately following the incident. Minor track out not causing a public nuisance and no risk of being washed to stormwater systems may be removed at end of day or before forecast storm event whichever comes first.

Maintenance Personnel: Jeff Scadden: 801-814-2323

Applicable Trades: All

Detail: NA

2.7.1 Solid Waste: Waste Policies

Operation or Site Condition: Solid waste management procedures and practices are designed to minimize or eliminate the discharge of pollutants to the drainage system or to watercourses as a result of the creation, stockpiling, or removal of construction site wastes.

Instruction:

Littering on the project site shall be prohibited. To prevent clogging of the storm drainage system litter and debris removal from drainage grates, trash racks, and ditch lines shall be a priority.

Installation Schedule: NA

Maintenance Requirements: NA

Applicable Trades: All trades.

Maintenance Personnel: Jeff Scadden: 801-814-2323

Detail: NA

2.8.1 Spill Control Plan

Operations or Site Condition: Spills can happen at any time. The project will extend into winter necessitating a plan that will work in freezing temperatures and snowy conditions.

Instruction:

1. Containment: Two 5 gal buckets with lids filled with sand are located at the low side of the project in the park strip, see site plan. Keep lid closed so the sand will stay dry. Wet sand will likely freeze solid. These are intended for containing flowing spills and absorbing spilled liquids, however, when site conditions allow dirt may also be used. You will need your own shovel.
2. Cleanup and Disposal: It will only take minutes to dam then absorb any liquid. Clean up immediately following the spill event. Dispose waste in BMP 2.6.5 unless the SDS directs otherwise.

Installation Schedule: Prior to any land disturbance

Maintenance Requirements: Replace as used

Maintenance Personnel: Jeff Scadden: 801-814-2323

Applicable Trades: All

Detail: NA

BMP C101: PRESERVING NATURAL VEGETATION

Purpose

The purpose of preserving natural vegetation is to reduce erosion wherever practicable. Limiting site disturbance is the single most effective method for reducing erosion. For example, conifers can hold up to about 50 percent of all rain that falls during a storm. Up to 20-30 percent of this rain may never reach the ground but is taken up by the tree or evaporates. Another benefit is that the rain held in the tree can be released slowly to the ground after the storm.

Conditions of Use

- *Natural vegetation should be preserved on steep slopes, near perennial and intermittent watercourses or swales, and on building sites in wooded areas.*
- As required by local governments.

Design and Installation Specifications

Natural vegetation can be preserved in natural clumps or as individual trees, shrubs and grasses.

The preservation of individual plants is more difficult because heavy equipment is generally used to remove unwanted vegetation. The points to remember when attempting to save individual plants are:

- *Is the plant worth saving? Consider the location, species, size, age, vigor, and the work involved. Local governments may also have ordinances to save natural vegetation and trees.*
- *Fence or clearly mark areas around trees that are to be saved. It is preferable to keep ground disturbance away from the trees at least as far out as the dripline.*

Maintenance Standards

- *Inspect flagged and/or fenced areas regularly to make sure flagging or fencing has not been removed or damaged. If the flagging or fencing has been damaged or visibility reduced, it shall be repaired or replaced immediately and visibility restored.*
- *If tree roots have been exposed or injured, “prune” cleanly directly above the damaged roots and recover with native soils. Treatment of sap flowing trees (fir, hemlock, pine, soft maples) is not advised as sap forms a natural healing barrier.*

BMP C105: STABILIZED CONSTRUCTION ENTRANCE

Purpose

Construction entrances are stabilized to reduce the amount of sediment transported onto paved roads by vehicles or equipment by constructing a stabilized pad of course aggregate at entrances to construction sites.

Conditions of Use

Construction entrances shall be stabilized wherever traffic will be leaving a construction site and traveling on paved roads or other paved areas within 1,000 feet of the site.

Design and Installation Specifications

- See Figure for details.
- A separation geotextile shall be placed under the aggregate to prevent fine sediment from pumping up into the rock pad. The geotextile shall meet the following standards:

Grab Tensile Strength (ASTM D4751)	200 psi min.
Grab Tensile Elongation (ASTM D4632)	30% max.
Mullen Burst Strength (ASTM D3786-80a)	400 psi min.
AOS (ASTM D4751)	20-45 (U.S. standard sieve size)

- Consider early installation of the first lift of asphalt in areas that will be paved; this can be used as a stabilized entrance. Also consider the installation of excess concrete as a stabilized entrance. During large concrete pours, excess concrete is often available for this purpose.

- Fencing (see BMP C103) shall be installed as necessary to restrict traffic to the construction entrance.
- Whenever possible, the entrance shall be constructed on a firm, compacted subgrade. This can substantially increase the effectiveness of the pad and reduce the need for maintenance.

Maintenance Standards

- Additional aggregate shall be added if the pad is no longer in accordance with the specifications.
- If the entrance is not preventing sediment from being tracked onto pavement, then alternative measures to keep the streets free of sediment shall be used. This may include street sweeping, an increase in the dimensions of the entrance, or the installation of a wheel wash.
- Any sediment that is tracked onto pavement shall be removed by shoveling or street sweeping. The sediment collected by sweeping shall be removed or stabilized on site. The pavement shall not be cleaned by washing down the street, except when sweeping is ineffective and there is a threat to public safety. If it is necessary to wash the streets, the construction of a small sump shall be considered. The sediment would then be washed into the sump where it can be controlled.
- Any aggregate that is loosened from the pad, which end up on the roadway shall be removed immediately.
- If vehicles are entering or exiting the site at points other than the construction entrance(s), fencing (see BMP C103) shall be installed to control traffic.
- Upon project completion and site stabilization, all construction accesses intended as permanent access for maintenance shall be permanently stabilized.

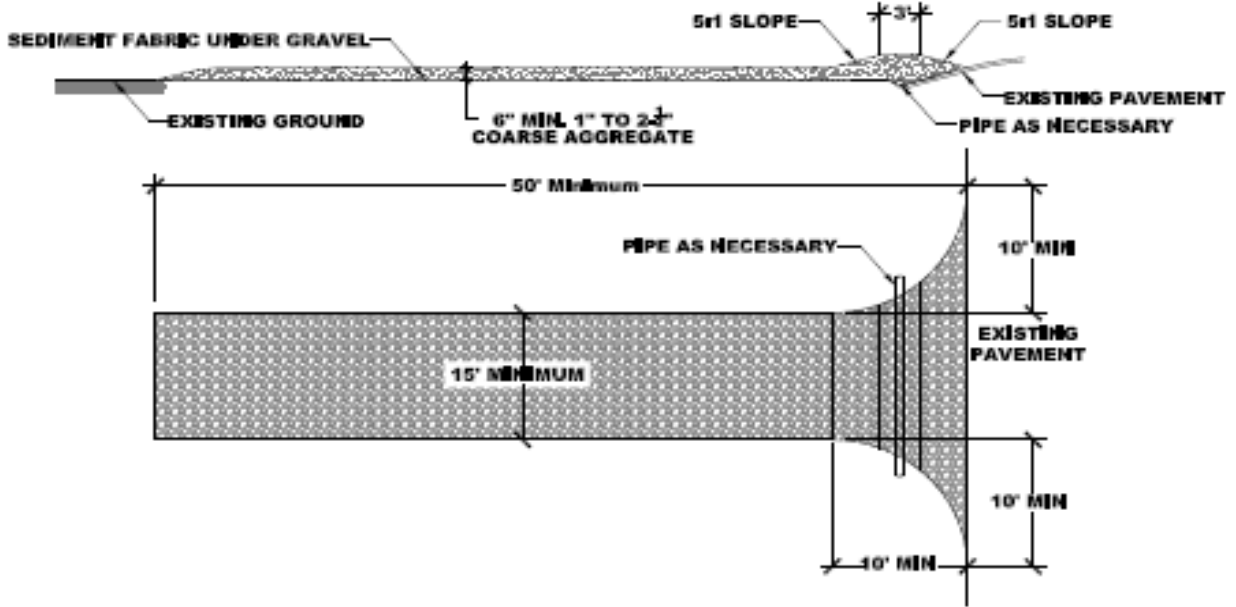

STABILIZED CONSTRUCTION ENTRANCE SHALL BE MAINTAINED UNTIL SUCH TIME AS ROADS ARE ASPHALTED AND INDIVIDUAL HOME LOTS ARE BEING DEVELOPED.

BMP C106: WHEEL WASH

Purpose

Wheel washes reduce the amount of sediment transported onto paved roads by motor vehicles.

Conditions of Use

When a stabilized construction entrance (see BMP C105) is not preventing sediment from being tracked onto pavement, a wheel wash is to be used.

- Wheel washing is generally an effective BMP when installed with careful attention to topography. For example, a wheel wash can be detrimental if installed at the top of a slope abutting a right-of-way where the water from the dripping truck can run unimpeded into the street.
- Pressure washing combined with an adequately sized and surfaced pad with direct drainage to a large 10-foot x 10-foot sump can be very effective.

Design and Installation Specifications

Suggested details are shown in the Figure. A minimum of 6 inches of asphalt treated base (ATB) over crushed base material or 8 inches over a good subgrade is recommended to pave the wheel wash.

Use a low clearance truck to test the wheel wash before paving. Either a belly dump or lowboy will work well to test clearance.

Keep the water level from 12 to 14 inches deep to avoid damage to truck hubs and filling the truck tongues with water.

Midpoint spray nozzles are only needed in extremely muddy conditions.

Wheel wash systems should be designed with a small grade change, 6 to 12 inches for a 10-foot-wide pond, to allow sediment to flow to the low side of pond to help prevent re-suspension of sediment. A drainpipe with a 2- to 3-foot riser should be installed on the low side of the pond to allow for easy cleaning and refilling. Polymers may be used to promote coagulation and flocculation in a closed-loop system. Polyacrylamide (PAM) added to the wheel wash water at a rate of 0.25 - 0.5 pounds per 1,000 gallons of water increases effectiveness and reduces cleanup time.

Maintenance Standards

The wheel wash should start out the day with fresh water.

The wash water should be changed a minimum of once per day. On large earthwork jobs where more than 10-20 trucks per hour are expected, the wash water will need to be changed more often.

Wheel wash or tire bath wastewater shall be discharged to a separate onsite treatment system, such as closed-loop recirculation or land application, or to the sanitary sewer with proper local sewer district approval.

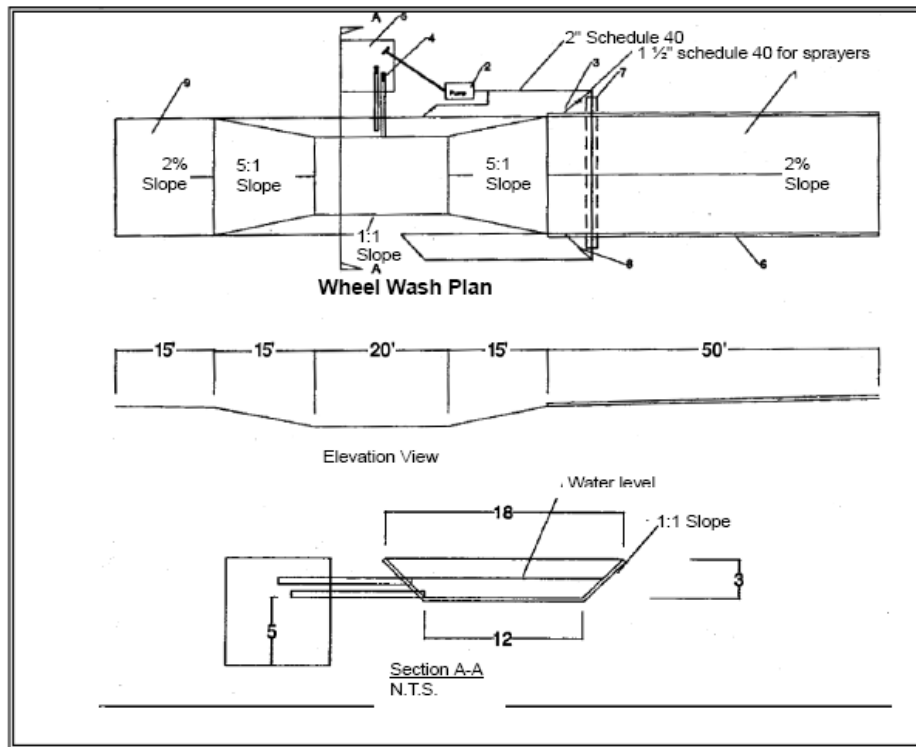

Notes:

1. Asphalt construction entrance 6 in. asphalt treated base (ATB).
2. 3-inch trash pump with floats on the suction hose.
3. Midpoint spray nozzles, if needed.
4. 6-inch sewer pipe with butterfly valves. Bottom one is a drain. Locate top pipe's invert 1 foot above bottom of wheel wash.
5. 8 foot x 8 foot sump with 5 feet of catch. Build so can be cleaned with trackhoe.
6. Asphalt curb on the low road side to direct water back to pond.
7. 6-inch sleeve under road.
8. Ball valves.
9. 15 foot. ATB apron to protect ground from splashing water.

BMP C140: DUST CONTROL

Purpose

Dust control prevents wind transport of dust from disturbed soil surfaces onto roadways, drainage ways, and surface waters.

Conditions for Use

- In areas (including roadways) subject to surface and air movement of dust where on-site and off-site impacts to roadways, drainage ways, or surface waters are likely

Design and Installation Specifications

- Limit dust generation by clearing only those areas where immediate activity will take place, leaving the remaining area(s) in the original condition, if stable. Maintain the original ground cover as long as practical.
- Sprinkle the site with water until surface is wet. Repeat as needed.
- Spray exposed soil areas with a dust palliative, following the manufacturer's instructions and cautions regarding handling and application. Used oil is prohibited from use as a dust suppressant. Local governments may approve other dust palliatives such as calcium chloride or PAM.
- PAM (BMP C126) added to water at a rate of 0.5 lbs. per 1,000 gallons of water per acre and applied from a water truck is more effective than water alone.

Techniques that can be used for unpaved roads and lots include:

- Lower speed limits. High vehicle speed increases the amount of dust stirred up from unpaved roads and lots.
- Add surface gravel to reduce the source of dust emission. Limit the amount of fine particles (those smaller than .075 mm) to 10 to 20 percent.
- Encourage the use of alternate, paved routes, if available.
- Restrict use by tracked vehicles and heavy trucks to prevent damage to road surface and base.
- Apply chemical dust suppressants using the admix method, blending the product with the top few inches of surface material. Suppressants may also be applied as surface treatments.
- Use vacuum street sweepers.
- Remove mud and other dirt promptly so it does not dry and then turn into dust.
- Limit dust-causing work on windy days.

Maintenance Standards

- Respray area as necessary to keep dust to a minimum.

BMP C151: CONCRETE WASTE MANAGEMENT

Purpose

Concrete work can generate process water and slurry that contain fine particles and high pH, both of which can violate water quality standards in the receiving water. This BMP is intended to minimize and eliminate concrete process water and slurry from entering the storm water system.

Conditions for Use

Any time concrete is used, these management practices shall be utilized. Concrete construction projects include, but are not limited to, the following:

- Curbs
- Sidewalks
- Roads
- Bridges
- Foundations
- Floors

Design and Installation Specifications

- Store wet and dry materials under cover and away from drainage areas.

- Create designated concrete cleanout area by excavation or installing berms according to the detail sheet in Appendix A.
- Avoid mixing excess amounts of fresh concrete on-site.
- Perform washout of concrete trucks off-site or in designated areas only.
- Do not wash out concrete trucks into storm drains, open ditches, streets or vacant properties.
- Do not allow excess concrete to be dumped on-site, except in designated areas.
- When washing concrete to remove fine particles and expose the aggregate, avoid creating runoff by draining the water into a bermed or level area.
- Train employees, contractors and subcontractors in proper concrete waste management.

Maintenance Standards

- Inspect subcontractors to ensure that concrete wastes are being properly managed.
- If using a temporary pit, dispose hardened concrete on a regular basis.

BMP C153: MATERIAL DELIVERY, STORAGE AND CONTAINMENT

Purpose

Prevent, reduce, or eliminate the discharge of pollutants from material delivery and storage to the stormwater system or watercourses by minimizing the storage of hazardous materials onsite, storing materials in a designated area, and installing secondary containment.

Conditions of Use

These procedures are suitable for use at all construction sites with delivery and storage of the following materials:

- Petroleum products such as fuel, oil and grease
- Soil stabilizers and binders (e.g. Polyacrylamide)
- Fertilizers, pesticides and herbicides
- Detergents
- Asphalt and concrete compounds
- Hazardous chemicals such as acids, lime, adhesives, paints, solvents and curing compounds
- Any other material that may be detrimental if released to the environment

Design and Installation Specifications

The following steps should be taken to minimize risk:

- Temporary storage area should be located away from vehicular traffic, near the construction entrance(s), and away from waterways or storm drains.
- Material Safety Data Sheets (MSDS) should be supplied for all materials stored. Chemicals should be kept in their original labeled containers.
- Hazardous material storage on-site should be minimized.
- Hazardous materials should be handled as infrequently as possible.
- During the wet weather season (Oct 1 – April 30), consider storing materials in a covered area.
- Materials should be stored in secondary containments, such as earthen dikes.
- Do not store chemicals, drums, or bagged materials directly on the ground. Place these items on a pallet and, when possible, in secondary containment.

Material Storage Areas and Secondary Containment Practices:

- Liquids, petroleum products, and substances listed in 40 CFR Parts 110, 117, or 302 shall be stored in approved containers and drums and shall not be overfilled. Containers and drums shall be stored in temporary secondary containment facilities.
- Temporary secondary containment facilities shall provide for a spill containment volume able to contain precipitation from a 25 year, 24 hour storm event, plus 10% of the total enclosed container volume of all containers, or 110% of the capacity of the largest container within its boundary, whichever is greater.

- Secondary containment facilities shall be impervious to the materials stored therein for a minimum contact time of 72 hours.
- Sufficient separation should be provided between stored containers to allow for spill cleanup and emergency response access.
- During the wet weather season (Oct 1 – April 30), each secondary containment facility shall be covered during non-working days, prior to and during rain events.
- Keep material storage areas clean, organized and equipped with an ample supply of appropriate spill clean-up material (spill kit).

BMP C155: VEHICLE EQUIPMENT FUELING/CLEANING

Purpose

Prevent or reduce impacts to storm water due to fuel spills, fuel leaks and discharge of pollutants from vehicle and equipment cleaning by the use of off-site facilities, performing activities in designated and controlled areas only and training of employees and subcontractors.

Conditions of Use

- Sending vehicles/equipment off-site should be done in conjunction with Stabilized Construction Entrance.

Design and Installation Specifications

- Use off-site fueling stations and commercial washing facilities as much as possible. Fueling or cleaning vehicles and equipment outdoors or in areas where fuel may spill/leak or wash water flow onto paved surfaces or into drainage pathways can pollute storm water. If you fuel or clean a large number of vehicles or pieces of equipment, consider using off-site stations. These businesses are better equipped to handle fuel, spills and disposal of wash waters properly.
- If fueling must occur on-site, use designated areas, located away from drainage courses, to prevent the runoff of storm water and the runoff of spills. Discourage “topping-off” of fuel tanks.
- Always use secondary containment, such as a drain pan or drop cloth, when fueling to catch spills/leaks. Place a stockpile of spill cleanup materials where it will be readily accessible. Use absorbent materials promptly and dispose of properly.
- Carry out all Federal and State requirements regarding stationary above ground storage tanks. Avoid mobile fueling of mobile construction equipment around the site; rather, transport the equipment to designated fueling areas. With the exception of tracked equipment such as bulldozers

and perhaps forklifts, most vehicles should be able to travel to a designated area with little lost time. Train employees and subcontractors in proper fueling and cleanup procedures.

- If washing must occur on-site, use designated, bermed wash areas to prevent wash water contact with storm water, creeks, rivers, and other water bodies. The wash area can be sloped for wash water collection and subsequent infiltration into the ground.
- Use as little water as possible to avoid having to install erosion and sediment controls for the wash area. Use phosphate-free biodegradable soaps. Educate employees and subcontractors on pollution prevention measures. Do not permit steam cleaning on-site. Steam cleaning can generate significant pollutant concentrations.

Maintenance Standards

- Keep ample supplies of spill cleanup materials on-site.
- Inspect fueling areas and storage tanks on a regular schedule.
- Minimal, some berm repair may be necessary.

BMP C190: PORTABLE TOILETS

Purpose

Provide temporary on-site sanitary facilities for construction personnel.

Conditions of Use

- All sites with no permanent sanitary facilities or where permanent facilities are too far from job activities.

Design and Installation Specifications

- Locate portable toilets in convenient locations throughout the site.
- Prepare level, gravel surface and provide clear access to the toilets for servicing and for on-site personnel.
- Construct a minimum 1' high earth berm around the perimeter of the toilet to allow sufficient volume to control spill/leaks.

Maintenance Standards

- Regular inspection and waste collection must be completed by licensed service provider.
- The area below the outlet must be stabilized with a riprap apron or other suitable improvement.
- If the pipe slope drain is conveying sediment-laden water, direct all flows into the sediment trapping facility.

Maintenance Standards

Check inlet and outlet points regularly, especially after storms.

The inlet should be free of undercutting, and no water should be going around the point of entry. If there are problems, the headwall should be reinforced with compacted earth or sand bags.

BMP C220: STORM DRAIN INLET PROTECTION

Purpose

To prevent coarse sediment from entering drainage systems prior to permanent stabilization of the disturbed area.

Conditions of Use

Protection should be provided for all storm drain inlets downslope and within 500 feet of a disturbed or construction area, unless the runoff that enters the catch basin will be conveyed to a sediment pond or trap. Inlet protection may be used anywhere to protect the drainage system. It is likely that the drainage system will still require cleaning.

The following table lists several options for inlet protection. All of the methods for storm drain inlet protection are prone to plugging and require a high frequency of maintenance. Drainage areas should be limited to 1 acre or less. Emergency overflows may be required where stormwater ponding would cause a hazard. If an emergency overflow is provided, additional end-of-pipe treatment may be required.

Storm Drain Inlet Protection			
Type of Inlet Protection	Emergency Overflow	Applicable for Paved/Earthen Surfaces	Conditions of Use
Drop Inlet Protection			
Excavated drop inlet protection	Yes, temporary flooding will occur	Earthen	Applicable for heavy flows. Easy to maintain. Large area Requirement: 30'x30'/acre
Block and gravel drop inlet protection	Yes	Paved or Earthen	Applicable for heavy concentrated flows. Will not pond.

Gravel and wire drop inlet protection	No		Applicable for heavy concentrated flows. Will pond. Can withstand traffic.
Catch basin and curb inlet filters	Yes	Paved or Earthen	Frequent maintenance required.
Curb Inlet Protection			
Catch basin and curb inlet filters	Yes	Paved or Earthen	Frequent maintenance required.
Curb inlet protection with straw bales or waddle block and gravel curb inlet protection	Small capacity overflow	Paved	Used for sturdy, more compact installation.
	Yes	Paved	Sturdy, but limited filtration.

Design and Installation Specifications

Excavated Drop Inlet Protection - An excavated impoundment around the storm drain. Sediment settles out of the stormwater prior to entering the storm drain.

- Depth 1-2 ft as measured from the crest of the inlet structure.
- Side Slopes of excavation no steeper than 2:1.
- Minimum volume of excavation 35 cubic yards.
- Shape basin to fit site with longest dimension oriented toward the longest inflow area.
- Install provisions for draining to prevent standing water problems.

- Clear the area of all debris.
- Grade the approach to the inlet uniformly.
- Drill weep holes into the side of the inlet.
- Protect weep holes with screen wire and washed aggregate.
- Seal weep holes when removing structure and stabilizing area.
- It may be necessary to build a temporary dike to the down slope side of the structure to prevent bypass flow.

Block and Gravel Filter - A barrier formed around the storm drain inlet with standard concrete blocks and gravel. See Figure.

- Height 1 to 2 feet above inlet.
- Recess the first row 2 inches into the ground for stability.
- Support subsequent courses by placing a 2x4 through the block opening.
- Do not use mortar.
- Lay some blocks in the bottom row on their side for dewatering the pool.
- Place hardware cloth or comparable wire mesh with ½-inch openings over all block openings.

- Place gravel just below the top of blocks on slopes of 2:1 or flatter.
- An alternative design is a gravel donut or wattle.
- 1-foot wide level stone area between the structure and the inlet.

Gravel and Wire Mesh Filter - A gravel barrier placed over the top of the inlet. This structure does not provide an overflow.

- Hardware cloth or comparable wire mesh with ½-inch openings.
- Coarse aggregate.
- Height 1-foot or more, 18 inches wider than inlet on all sides.
- Place wire mesh over the drop inlet so that the wire extends a minimum of 1-foot beyond each side of the inlet structure.
- If more than one strip of mesh is necessary, overlap the strips.
- Place coarse aggregate over the wire mesh.
- The depth of the gravel should be at least 12 inches over the entire inlet opening and extend at least 18 inches on all sides.

Catchbasin and Curb Inlet Filters – Inserts must be installed according to manufacturer's details and requirements. Inspection and maintenance may be required often based on sediment loads and rainfall events.

- For Nyloplast curb inlets, use Storm-PURE Catch Basin Insert or approved equal.
- For standard concrete curb inlets, use Siltsack manufactured by ACF Environmental, or approved equal.
- High-flow bypass that will not clog under normal use at a construction site.
- The catchbasin filter is inserted in the catchbasin just below the grating.

Curb Inlet Protection with Straw Bales or Waddle – Barrier formed around a curb inlet with straw bales or barrier using commercially available “waddle” products which incorporate filtering material or media. Install “waddle” applications according to manufacturer’s specifications.

Block and Gravel Curb Inlet Protection – Barrier formed around an inlet with concrete blocks and gravel. See Figure.

- Wire mesh with ½-inch openings.
- Place two concrete blocks on their sides abutting the curb at either side of the inlet opening. These are spacer blocks.
- Place a 2x4 stud through the outer holes of each spacer block to align the front blocks.
- Place blocks on their sides across the front of the inlet and abutting the spacer blocks.
- Place wire mesh over the outside vertical face.
- Pile coarse aggregate against the wire to the top of the barrier.

Curb and Gutter Sediment Barrier – Sandbag, rock berm or straw bale 2 feet high and 2 feet wide in a horseshoe shape. See Figure.

- Construct a horseshoe shaped berm, faced with coarse aggregate if using riprap, 2 feet high and 2 feet wide, at least 2 feet from the inlet.
- Construct a horseshoe shaped sedimentation trap on the outside of the berm sized to sediment trap standards for protecting a culvert inlet.

Maintenance Standards

- Catch basin filters should be inspected frequently, especially after storm events. If the insert or bag becomes clogged or fills to 50% capacity, it should be cleaned or replaced.
- For systems using stone filters: If the stone filter becomes clogged with sediment, the stones must be pulled away from the inlet and cleaned or replaced. Since cleaning of gravel at a construction site may be difficult, an alternative approach would be to use the clogged stone as fill and put fresh stone around the inlet.
- Do not wash sediment into storm drains while cleaning. Spread all excavated material evenly over the surrounding land area or stockpile and stabilize as appropriate.

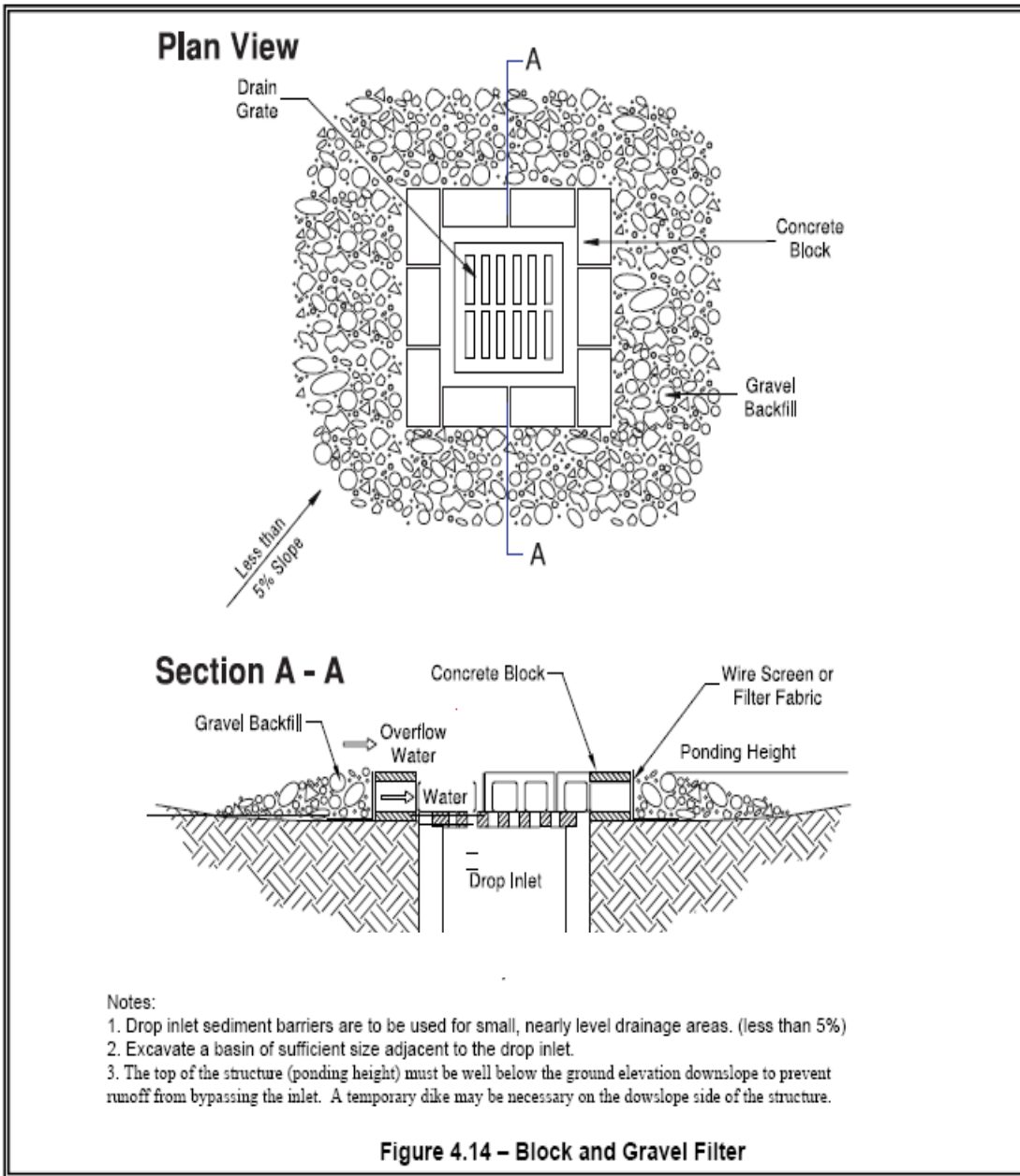

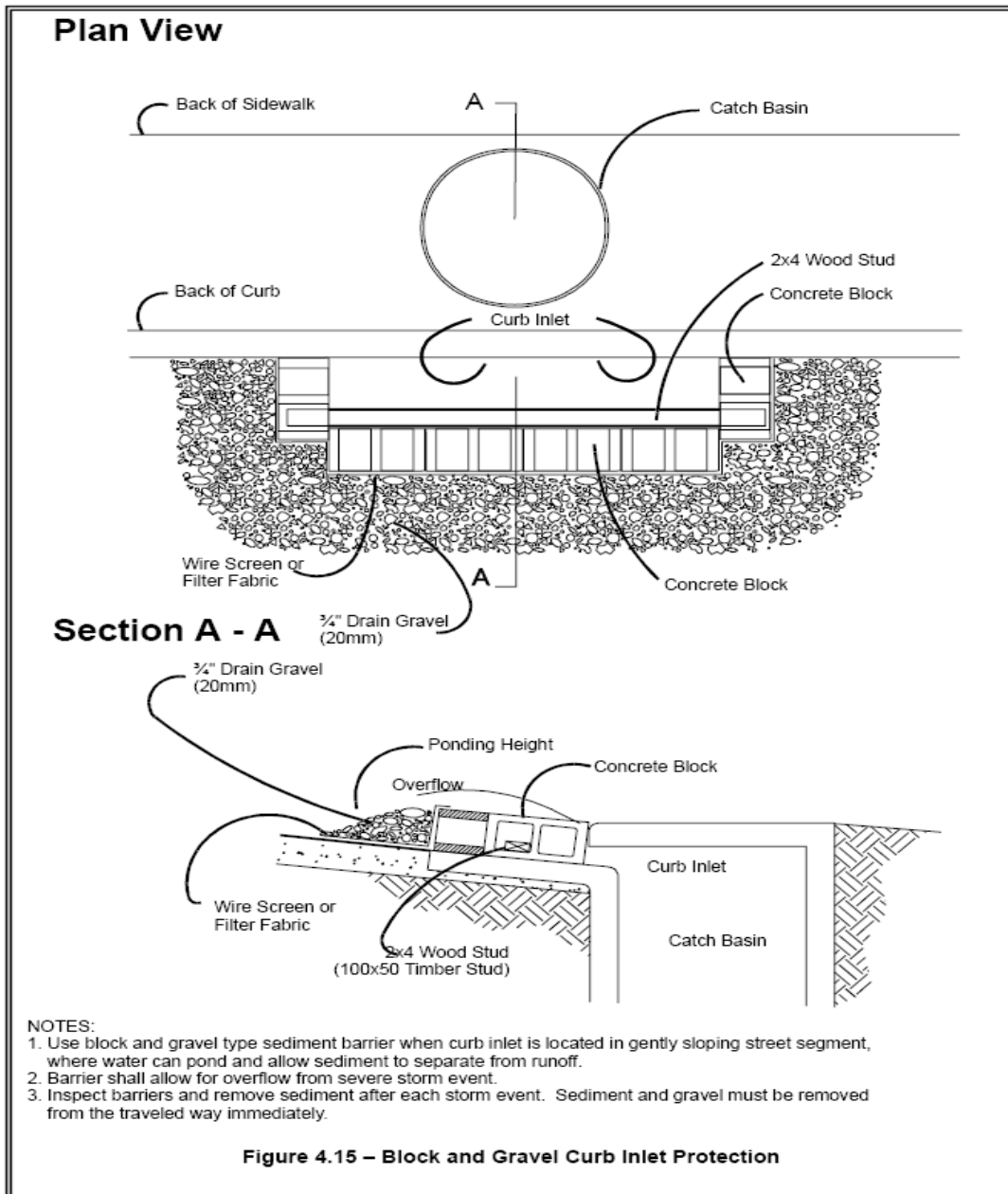

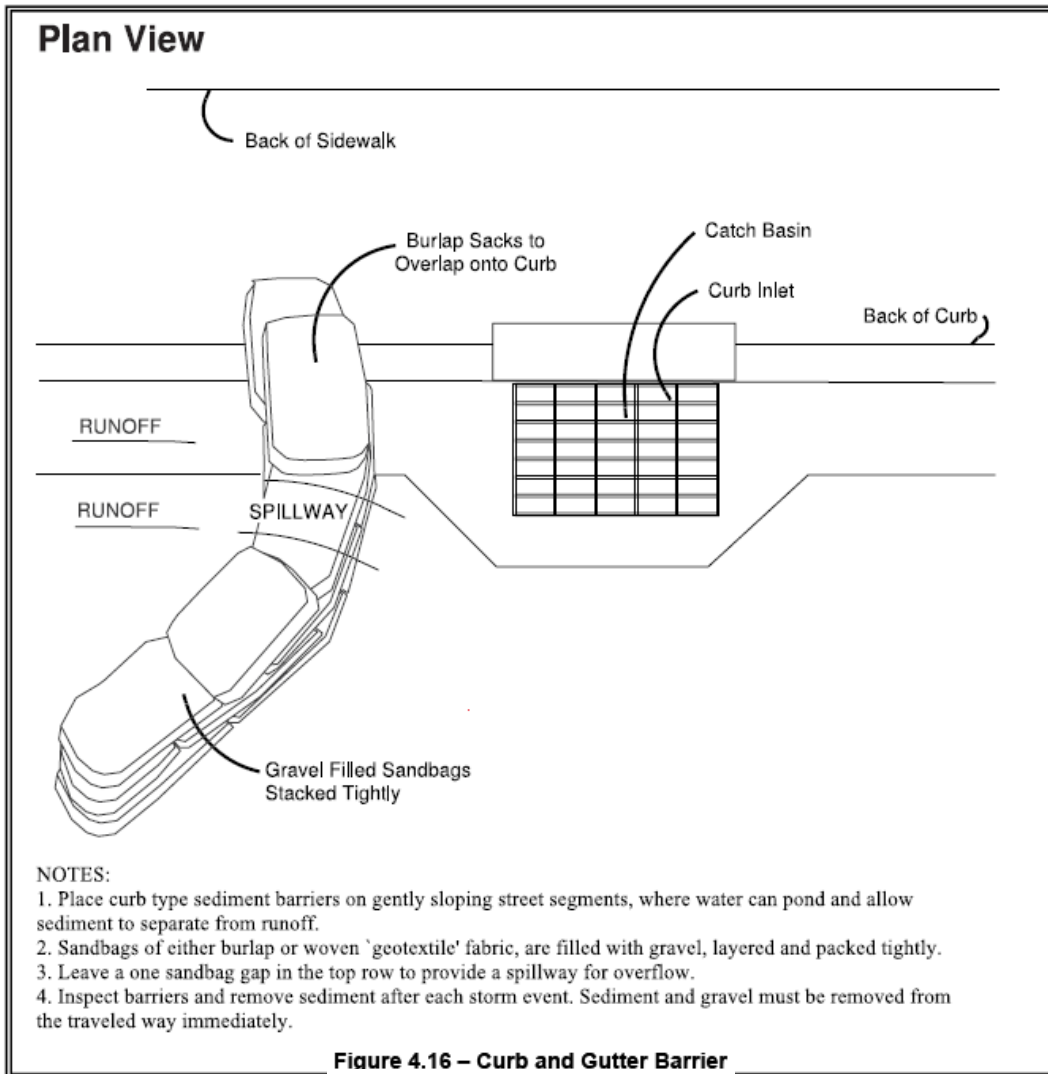

BMP C233: SILT FENCE

Purpose

Use of a silt fence reduces the transport of coarse sediment from a construction site by providing a temporary physical barrier to sediment and reducing the runoff velocities of overland flow. See Figure for details on silt fence construction.

Conditions of Use

Silt fence may be used downslope of all disturbed areas.

- Silt fence is not intended to treat concentrated flows, nor is it intended to treat substantial amounts of overland flow. Any concentrated flows must be conveyed through the drainage system to a sediment pond. The only circumstance in which overland flow can be treated solely by a silt fence, rather than by a sediment pond, is when the area draining to the fence is one acre or less and flow rates are less than 0.5 cfs.
- Silt fences should not be constructed in streams or used in V-shaped ditches. They are not an adequate method of silt control for anything deeper than sheet or overland flow.

Design and Installation Specifications

- Used for drainage areas resulting in sheet or overland flow rather than concentrated flows.
- Maximum slope steepness (normal (perpendicular) to fence line) 2:1.
- Maximum sheet or overland flow path length to the fence of 150 feet.
- No flows greater than 0.5 cfs.

- The geotextile used shall meet the following standards. All geotextile properties listed below are minimum average roll values (i.e., the test result for any sampled roll in a lot shall meet or exceed the values shown in the following Table):
 - Standard strength fabrics shall be supported with wire mesh, chicken wire, 2-inch x 2-inch wire, safety fence, or jute mesh to increase the strength of the fabric. Silt fence materials are available that have synthetic mesh backing attached.
 - Filter fabric material shall contain ultraviolet ray inhibitors and stabilizers to provide a minimum of six months of expected usable construction life at a temperature range of 0°F. to 120°F.
 - Standard Notes for construction plans and specifications follow. Refer to Figure for standard silt fence details.

The contractor shall install and maintain temporary silt fences at the locations shown in the Plans. The silt fences shall be constructed in the areas of clearing, grading, or drainage prior to starting those activities. A silt fence shall not be considered temporary if the silt fence must function beyond the life of the contract. The silt fence shall prevent soil carried by runoff water from going beneath, through, or over the top of the silt fence, but shall allow the water to pass through the fence.

The minimum height of the top of silt fence shall be 2 feet and the maximum height shall be 2½ feet above the original ground surface.

The geotextile shall be attached on the up-slope side of the posts and support system with staples, wire, or in accordance with the manufacturer's recommendations. The geotextile shall be attached to the posts in a manner that reduces the potential for geotextile tearing at the staples, wire, or other connection device. Silt fence back-up support for the geotextile in the form of a wire or plastic mesh is dependent on the properties of the geotextile selected for use. If wire or plastic back-up mesh is used, the mesh shall be fastened securely to the up-slope of the posts with the geotextile being up-slope of the mesh back-up support.

The geotextile at the bottom of the fence shall be buried in a trench to a minimum depth of 4 inches below the ground surface. The trench shall be backfilled and the soil tamped in place over the buried portion of the geotextile, such that no flow can pass beneath the fence and scouring cannot occur.

When wire or polymeric back-up support mesh is used, the wire or polymeric mesh shall extend into the trench a minimum of 3 inches.

The fence posts shall be placed or driven a minimum of 18 inches. A minimum depth of 12 inches is allowed if topsoil or other soft subgrade soil is not present and a minimum depth of 18 inches cannot be reached. Fence post depths shall be increased by 6 inches if the fence is located on slopes of 3:1 or steeper and the slope is perpendicular to the fence. If required post depths cannot be obtained, the posts shall be adequately secured by bracing or guying to prevent overturning of the fence due to sediment loading.

Silt fences shall be located on contour as much as possible, except at the ends of the fence, where the fence shall be turned uphill such that the silt fence captures the runoff water and prevents water from flowing around the end of the fence. If the fence must cross contours, with the exception of the ends of the fence, gravel check dams placed perpendicular to the back of the fence shall be used to minimize concentrated flow and erosion along the back of the fence. The gravel check dams shall be approximately 1-foot deep at the back of the fence. It shall be continued perpendicular to the fence at the same elevation until the top of the check dam intercepts the ground surface behind the fence. The gravel check dams shall consist of crushed surfacing base course, gravel backfill for walls, or shoulder ballast. The gravel check dams shall be located every 10 feet along the fence where the fence must cross contours. The slope of the fence line where contours must be crossed shall not be steeper than 3:1.

Wood, steel or equivalent posts shall be used. Wood posts shall have minimum dimensions of 2 inches by 2 inches by 3 feet minimum length, and shall be free of defects such as knots, splits, or gouges.

Steel posts shall consist of either size No. 6 rebar or larger, ASTM A 120 steel pipe with a minimum diameter of 1-inch, U, T, L, or C shape steel posts with a minimum weight of 1.35 lbs./ft. or other steel posts having equivalent strength and bending resistance to the post sizes listed. The spacing of the support posts shall be a maximum of 6 feet.

Fence back-up support, if used, shall consist of steel wire with a maximum mesh spacing of 2 inches, or a prefabricated polymeric mesh. The strength of the wire or polymeric mesh shall be equivalent to or greater than 180 lbs. grab tensile strength. The polymeric mesh must be as resistant to ultraviolet radiation as the geotextile it supports.

Maintenance Standards

- Any damage shall be repaired immediately.
- If concentrated flows are evident uphill of the fence, they must be intercepted and conveyed to a sediment pond or other suitable control.
- It is important to check the uphill side of the fence for signs of the fence clogging and acting as a barrier to flow and then causing channelization of flows parallel to the fence. If this occurs, replace the fence or remove the trapped sediment.
- Sediment deposits shall either be removed when the deposit reaches approximately one-third the height of the silt fence, or a second silt fence shall be installed.
- If the filter fabric (geotextile) has deteriorated due to ultraviolet breakdown, it shall be replaced.

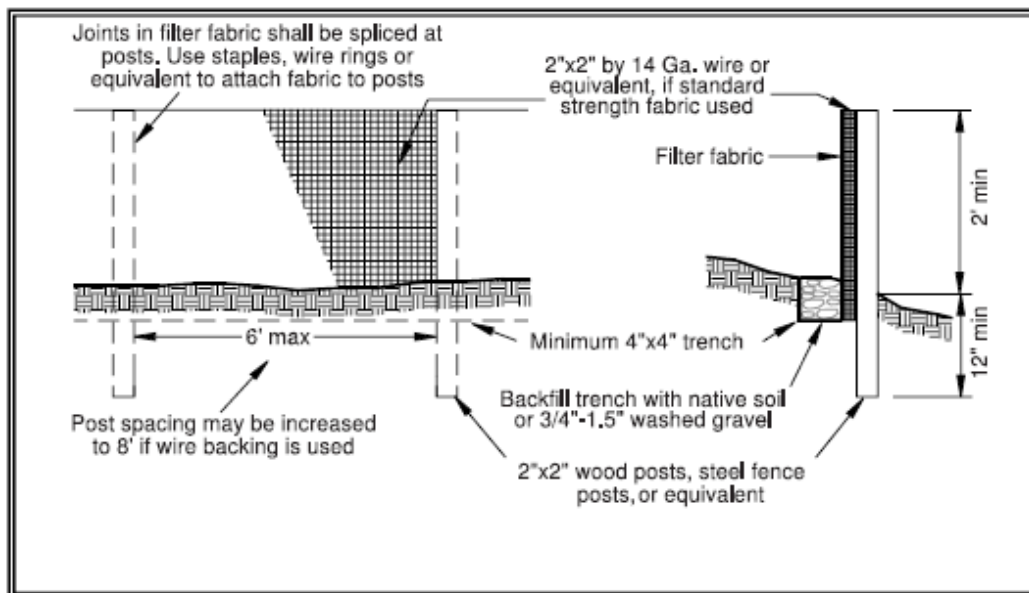

Silt Fence

Geotextile Standards	
Polymeric Mesh AOS (ASTM D4751)	0.60 mm maximum for slit film wovens (#30 sieve). 0.30 mm maximum for all other geotextile types (#50 sieve). 0.15 mm minimum for all fabric types (#100 sieve).
Water Permittivity (ASTM D4491)	0.02 sec ⁻¹ minimum
Grab Tensile Strength (ASTM D4632)	180 lbs. Minimum for extra strength fabric. 100 lbs minimum for standard strength fabric.
Grab Tensile Strength (ASTM D4632)	30% maximum
Ultraviolet Resistance (ASTM D4355)	70% minimum

BMP C254: STRAW WATTLE

Purpose

Straw wattles are temporary erosion and sediment control barriers consisting of straw that is wrapped in biodegradable tubular plastic or similar encasing material. They reduce the velocity and can spread the flow of rill and sheet runoff, and capture and retain sediment. Straw wattles are typically 8 to 10 inches in diameter and 25 to 30 feet in length. The wattles are placed in shallow trenches and placed with stakes, rebar, or sand bags along the contour of disturbed or newly constructed slopes or at the base of concrete or asphalt surfaces.

Conditions of Use

- Disturbed areas that require immediate erosion protection.
- Exposed soils or hard surfaces during the period of short construction delays, or over winter months.
- On slopes requiring stabilization until permanent vegetation can be established.
- Straw wattles are effective for one to two seasons.
- If conditions are appropriate, wattles can be staked to the ground using willow cuttings for added revegetation.
- Rilling can occur beneath wattles if not properly entrenched and water can pass between wattles if not tightly abutted together.

Design and Installation Specifications

- It is critical that wattles are installed perpendicular to the flow direction and parallel to the slope contour.

- Narrow trenches should be dug across the slope of contour to a depth of 3 to 5 inches on clay soils and soils with gradual slopes. On loose soils, steep slopes, and areas with high rainfall, the trenches should be dug to a depth of 5 to 7 inches, or $\frac{1}{2}$ to $\frac{2}{3}$ of the thickness of the wattle. On asphalt or concrete surfaces, wattles should be placed at the base of the slope with compacted soil on the upslope side. Sandbags should be used when wattles are placed on concrete, asphalt, or other hard surfaces.
- Start building trenches and installing wattles from the base of the slope and work up. Excavated material should be spread evenly along the uphill slope and compacted using hand tamping or other methods.
- Construct trenches at contour intervals of 3 to 30 feet apart depending on the steepness of the slope, soil type, and rainfall. The steeper the slope the closer together the trenches.
- Install the wattles snugly into the trenches and abut tightly end to end. Do not overlap the ends.
- Install stakes, rebar, or sandbags at each end of the wattle, and at a minimum 4-foot centers along entire length of wattle.
- If necessary, install pilot holes for the stakes using a straight bar to drive holes through the wattle and into the soil.
- At a minimum, wooden stakes should be approximately $\frac{3}{4}$ x $\frac{3}{4}$ x 24 inches. Willow cuttings or $\frac{3}{8}$ -inch rebar can also be used for stakes.

Maintenance Standards

- Stakes or rebar should be driven through the middle of the wattle, leaving 2 to 3 inches of the stake or rebar protruding above the wattle.
- Wattles may require maintenance to ensure they are in contact with soil or surface and thoroughly entrenched, especially after significant rainfall on steep sandy soils.
- Inspect the slope after significant storms and repair any areas where wattles are not tightly abutted or water has scoured beneath the wattles.

