

**WOODLAND ESTATES SUBDIVISION - UNIT 2 - AMENDMENT 5**  
**AMENDING LOT 46 WOODLAND ESTATES SUBDIVISION - UNIT 2**  
 LOCATED IN THE NORTHEAST QUARTER OF SECTION 23,  
 TOWNSHIP 5 NORTH, RANGE 1 WEST, SALT LAKE BASE AND MERIDIAN,  
 WEBER COUNTY, UTAH  
 OCTOBER 2017

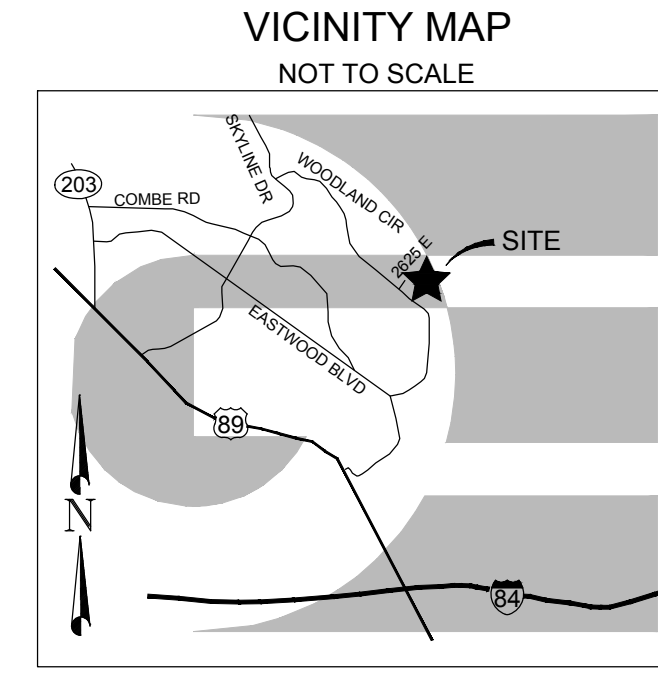

**BOUNDARY DESCRIPTION**  
 A PART OF THE NORTHEAST QUARTER OF SECTION 23, TOWNSHIP5 NORTH, RANGE1 WEST OF THE SALT LAKE BASE AND MERIDIAN, MORE PARTICULARLY DESCRIBED AS FOLLOWS:  
 BEGINNING AT THE NORTHERLY CORNER OF LOT 102 OF WOODLAND ESTATES SUBDIVISION UNIT 2, 2ND AMENDMENT; RUNNING ALONG THE WESTERLY LINE OF SAID LOT 102 SOUTH 38°53'55" WEST 229.16 FEET TO THE NORTHEASTERLY CORNER OF LOT 44 WOODLAND ESTATES SUBDIVISION - UNIT 2; THENCE NORTH 61°28'15" WEST 315.98 FEET ALONG THE NORTHEASTERLY BOUNDARY OF LOTS 44 AND 45 TO THE NORTHERLY CORNER OF SAID LOT 45 AND THE SOUTHEASTERLY RIGHT-OF-WAY LINE OF 2625 EAST STREET; THENCE ALONG SAID RIGHT-OF-WAY LINE ALONG THE ARC OF A CURVE TO THE LEFT 23.02 FEET, HAVING A RADIUS OF 50.00 FEET, A CENTRAL ANGLE OF 26°22'28", AND WHICH CHORD BEARS NORTH 15°19'58" EAST 22.81 FEET; THENCE SOUTH 83°56'37" EAST 24.02 FEET; THENCE SOUTH 89°08'38" EAST 32.89 FEET; THENCE NORTH 63°31'29" EAST 13.66 FEET; THENCE NORTH 11°57'29" WEST 9.12 FEET; THENCE NORTH 11°35'12" EAST 5.85 FEET; THENCE NORTH 44°05'36" EAST 11.44 FEET; THENCE NORTH 12°10'23" EAST 12.33 FEET TO THE SOUTHEASTERLY BOUNDARY OF LOT 47 OF SAID SUBDIVISION; THENCE ALONG SAID SOUTHEASTERLY LINE NORTH 74°20'31" EAST 228.37 FEET TO THE NORTHEASTERLY BOUNDARY OF SAID SUBDIVISION; THENCE ALONG SAID NORTHEASTERLY SOUTH 51°06'05" EAST 150.00 FEET TO THE POINT OF BEGINNING. CONTAINING 60,420 SQ.FT. OR 1.387 ACRES, MORE OR LESS.

All surveyed property corners or endpoints of property lines not already marked on the ground shall be marked pursuant to the Weber County Survey property corner detail sheet prior to the time of filing. WCO 45-3-5(a)  
 A note on the plat shall indicate the subdivision boundary and lot corners are set as required by state code and county ordinance. WCO 106-1-8(c)(2)  
 The subdivision boundary corners, lot corners, and centerline street monuments shall be noted on the final plat in conformance with county ordinance. WCO 106-1-8(c)(1)

A detailed description of monuments found and monuments set, indicated separately. UCA 17-23-17(3)(h)

The existing location, widths, and other dimensions of all existing or platted buildings and structures within and immediately adjacent (within 30') to the tract of land to be subdivided. Building where marked by a star. WCO 106-1-5(a)(6)

Please show existing address

The existing location, widths, and other dimensions of all existing or platted easements within and immediately adjacent (within 30') to the tract of land to be subdivided. WCO 106-1-5(a)(6)

The words "Basis of Bearings" must be shown on the plat between two existing, described government monuments. WCO 106-1-8(c)(1)d.; UCA 17-23-17(3)(d)

The plat shall have a detailed description of all monuments found and each one shall be referenced on the plat including the type, size, condition, and location in reference to the surface of the ground as well as a description or graphic depiction of the markings, date, agency, entity, or surveyor as inscribed on the monument. WCO 45-3-3(b)

**SURVEYOR'S CERTIFICATE**

I, KLINT H. WHITNEY, DO HEREBY CERTIFY THAT I AM A LICENSED PROFESSIONAL LAND SURVEYOR IN THE STATE OF UTAH AND THAT I HOLD CERTIFICATE NO. 8227228 IN ACCORDANCE WITH TITLE 58, CHAPTER 22, OF THE PROFESSIONAL ENGINEERS AND PROFESSIONAL LAND SURVEYORS ACT; I FURTHER CERTIFY THAT BY AUTHORITY OF THE OWNERS I HAVE COMPLETED A SURVEY OF THE PROPERTY AS SHOWN AND DESCRIBED ON THIS PLAT, AND HAVE SUBDIVIDED SAID PROPERTY INTO LOTS AND STREETS, TOGETHER WITH EASEMENTS, HEREAFTER TO BE KNOWN AS WOODLAND ESTATES SUBDIVISION - UNIT 2 - AMENDMENT 5 IN ACCORDANCE WITH SECTION 17-23-17 AND HAVE VERIFIED ALL MEASUREMENTS; THAT THE REFERENCE MONUMENTS SHOWN HEREON ARE LOCATED AS INDICATED AND ARE SUFFICIENT TO RETRACE OR REESTABLISH THIS SURVEY; THAT ALL LOTS MEET THE REQUIREMENTS OF THE LAND USE CODE; AND THAT THE INFORMATION SHOWN HEREIN IS SUFFICIENT TO ACCURATELY ESTABLISH THE LATERAL BOUNDARIES OF THE HEREIN DESCRIBED TRACT OF REAL PROPERTY.

SIGNED THIS \_\_\_\_\_ DAY OF \_\_\_\_\_, 2017.

The surveyor making the plat shall certify that the surveyor "has placed monuments as represented on the plat". UCA 17-27a-604(4)(b)(iii)



KLINT H. WHITNEY, PLS NO. 8227228

**OWNER'S DEDICATION**

I THE UNDERSIGNED OWNER OF THE HEREOF DESCRIBED TRACT OF LAND, HEREBY SET APART AND SUBDIVIDE THE SAME INTO LOTS, PARCELS AND STREETS AS SHOWN ON THIS PLAT AND NAME SAID TRACT:

To the public or To Weber County **WOODLAND ESTATES SUBDIVISION - UNIT 2 - AMENDMENT 5**

AND HEREBY DEDICATE A PERPETUAL EASEMENT OVER, UPON AND UNDER THE LANDS DESIGNATED ON THE PLAT AS PUBLIC UTILITY, THE SAME TO BE USED FOR THE INSTALLATION, MAINTENANCE AND OPERATION OF PUBLIC UTILITY SERVICE LINES, STORM DRAINAGE FACILITIES OR FOR THE PERPETUAL PRESERVATION OF WATER DRAINAGE CHANNELS IN THEIR NATURAL STATE WHICHEVER IS APPLICABLE AS MAY BE AUTHORIZED BY WEBER COUNTY, UTAH, WITH NO BUILDINGS OR STRUCTURES BEING ERRECTED WITHIN SUCH EASEMENTS.

SIGNED THIS \_\_\_ DAY OF \_\_\_\_\_, 2017.

BY: RYAN A. BORDER, JOINT TENANT BY: JOAN D. BORDER, JOINT TENANT

**ACKNOWLEDGEMENT**

STATE OF UTAH )  
 COUNTY OF WEBER )

On this \_\_\_\_\_ day of \_\_\_\_\_, 2017, before me \_\_\_\_\_, A Notary Public, personally appeared RYAN A. BORDER AND JOAN D. BORDER, HUSBAND AND WIFE AS JOINT TENANTS. Pread on the basis of satisfactory evidence to be the person(s) whose name(s) (is/are) subscribed to this instrument, and acknowledged (he/she/they) executed the same. Witness my hand and official seal.

STAMP \_\_\_\_\_ NOTARY PUBLIC \_\_\_\_\_

**LEGEND**

- ◆ WEBER COUNTY MONUMENT AS NOTED
- SUBDIVISION BOUNDARY
- - - ADJACENT PARCEL
- CENTERLINE
- - - EASEMENT

**NARRATIVE**

The written narrative shall contain the documentary, parol, and tangible evidence used in establishing the location of the lines of the survey. WCO 45-3-4(a).

THE PURPOSE OF THIS SURVEY WAS AMEND LOT 46 OF THE WOODLAND ESTATES SUBDIVISION UNIT 2 SO THAT THE OWNERS COULD MAKE AN ADDITION TO THEIR HOME. THE BOUNDARY OF SAID LOT WAS CHANGED PER COURT DECREE RECORDED AS E#2027004, AND BECAME NON-CONFORMING. THE SURVEY WAS ORDERED BY RYAN BORDER. ALL BEARINGS AND DISTANCES ARE BY RECORD EXCEPT THOSE THAT ADJOIN PARCEL NO.070890049, WHICH ARE BY COURT JUDGEMENT. THE BASIS OF BEARING IS BY RECORD ACCORDING TO THE SUBDIVISION PLAT OF WOODLAND ESTATES SUBDIVISION UNIT 2.

The narrative explains and identifies the found monuments or deed elements that controlled the established or reestablished lines. UCA 17-23-17(4)(a)(iii)

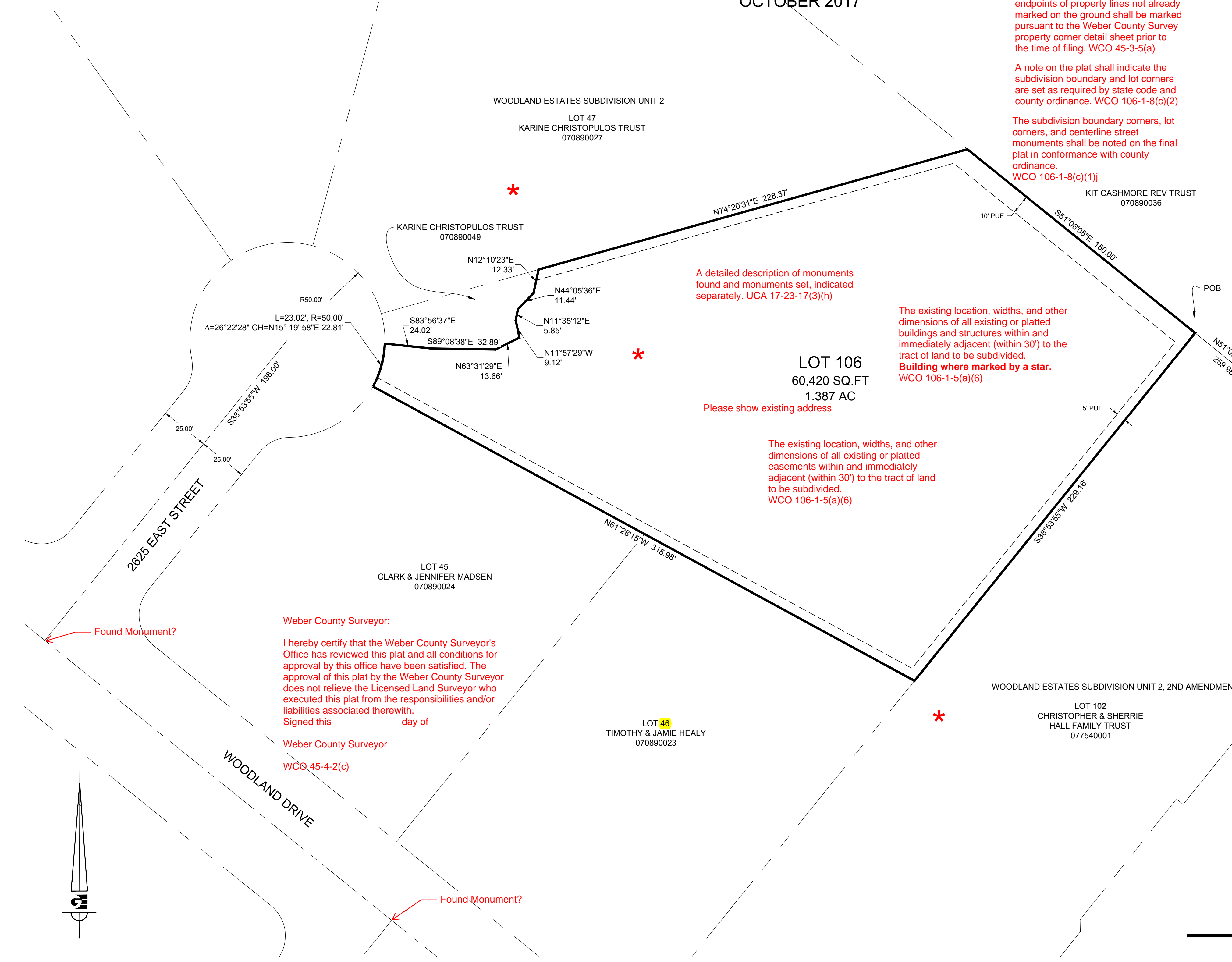

Weber County Surveyor:  
 I hereby certify that the Weber County Surveyor's Office has reviewed this plat and all conditions for approval by this office have been satisfied. The approval of this plat by the Weber County Surveyor does not relieve the Licensed Land Surveyor who executed this plat from the responsibilities and/or liabilities associated therewith.  
 Signed this \_\_\_\_\_ day of \_\_\_\_\_, 2017.  
 Weber County Surveyor  
 WCO 45-4-2(c)

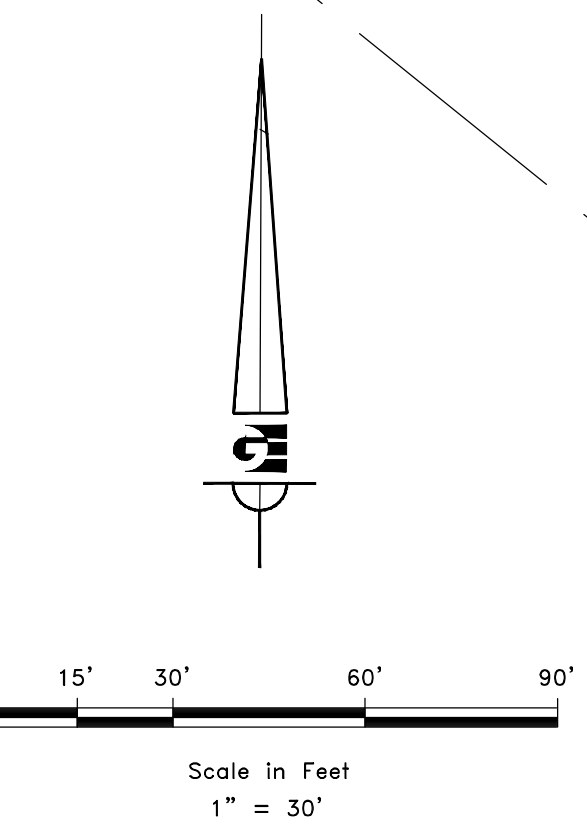

**WEBER COUNTY SURVEYOR**  
 I HEREBY CERTIFY THAT THE WEBER COUNTY SURVEYOR'S OFFICE HAS REVIEWED THIS PLAT AND IN MY OPINION THEY CONFORM WITH THE COUNTY ORDINANCE APPLICABLE THERETO AND NOW IN FORCE AND EFFECT.  
 SIGNED THIS \_\_\_\_\_ DAY OF \_\_\_\_\_, 2017.  
 COUNTY SURVEYOR

**WEBER COUNTY ENGINEER**  
 I HEREBY CERTIFY THAT THE REQUIRED PUBLIC IMPROVEMENT STANDARDS AND DRAWINGS FOR THIS SUBDIVISION CONFORM WITH COUNTY STANDARDS AND THE AMOUNT OF THE FINANCIAL GUARANTEE IS SUFFICIENT FOR THE INSTALLATION OF THESE IMPROVEMENTS.  
 SIGNED THIS \_\_\_\_\_ DAY OF \_\_\_\_\_, 2017.  
 COUNTY ENGINEER

**WEBER COUNTY PLANNING COMMISSION APPROVAL**  
 THIS IS TO CERTIFY THAT THIS SUBDIVISION WAS DULY APPROVED BY THE WEBER COUNTY PLANNING COMMISSION.  
 SIGNED THIS \_\_\_\_\_ DAY OF \_\_\_\_\_, 2017.  
 CHAIRMAN, WEBER COUNTY PLANNING COMMISSION

**WEBER COUNTY ATTORNEY**  
 I HAVE EXAMINED THE FINANCIAL GUARANTEE AND OTHER DOCUMENTS ASSOCIATED WITH THIS SUBDIVISION PLAT AND IN MY OPINION THEY CONFORM WITH THE COUNTY ORDINANCE APPLICABLE THERETO AND NOW IN FORCE AND EFFECT.  
 SIGNED THIS \_\_\_\_\_ DAY OF \_\_\_\_\_, 2017.  
 COUNTY ATTORNEY

**WEBER COUNTY COMMISSION ACCEPTANCE**  
 THIS IS TO CERTIFY THAT THIS SUBDIVISION PLAT, THE DEDICATION OF STREETS AND OTHER PUBLIC WAYS AND FINANCIAL GUARANTEE OF PUBLIC IMPROVEMENTS ASSOCIATED WITH THIS SUBDIVISION THEREON ARE HEREBY APPROVED AND ACCEPTED BY THE COMMISSIONERS OF WEBER COUNTY, UTAH.  
 SIGNED THIS \_\_\_\_\_ DAY OF \_\_\_\_\_, 2017.  
 CHAIRMAN, WEBER COUNTY COMMISSION  
 ATTEST: \_\_\_\_\_  
 NAME/TITLE

DEVELOPER: RYAN BORDER ADDRESS OGDEN, UT 84401 801-XXX-XXX	<b>S1</b> 1	COUNTY RECORDER ENTRY NO. _____ FEE PAID _____ FILED FOR AND RECORDED _____ AT _____ IN BOOK _____ OF OFFICIAL RECORDS, PAGE _____ RECORDED FOR _____ COUNTY RECORDER BY: _____
		CIVIL - LAND PLANNING MUNICIPAL - LAND SURVEYING 5150 SOUTH 375 EAST OGDEN, UT OFFICE: 801.476.0202 FAX: 801.476.0066