



Land Use Permit

Weber County Planning Commission

2380 Washington Blvd. STE 240

Ogden, UT 84401

Phone: (801) 399-8791 FAX: (801) 399-8862

webercountyutah.gov/planning

Permit Number: LUP260-2017

Permit Type: Structure

Permit Date: 08/14/2017

Applicant

Name:

Business: Mountain Resort Builders LLC

Address: 3625 S Honeycut Road
Salt Lake City, UT 84106

Phone: 801-259-9447

Owner

Name:

Business: SMHG Phase 1, LLC

Address: 3632 N Wolf Creek Drive
Eden, UT 84310

Phone: 435-640-7002

Parcel

Parcel: 231510027

Zoning: DRR-1 **Area:**

Sq Ft: 1717

Lot(s): 128

Subdivision: Horizon PRUD Amd 1

Address: 7864 E Horizon Run Eden, UT 84310

T - R - S - QS: 7N - 2E - 6 - SE

Proposal

Proposed Structure: Single Family Dwelling

Building Footprint: 1500

Proposed Structure Height: 34

Max Structure Height in Zone: 35

of Dwelling Units: 1

of Accessory Bldgs: 0

Off Street Parking Req'd: 1

***Is Structure > 1,000 Sq. Ft?** No

*If True Need Certif. Statement

Permit Checklist

Access Type: Front Lot Line

Alternative Access File #

Greater than 4218 ft above sea level? Yes

Wetlands/Flood Zone? No

Additional Setback Req'd. ? No

Meet Zone Area Frontage? Yes

> 200 ft from paved Road? No

Hillside Review Req'd? No

Culinary Water District: PMWSD

Waste Water System: PMWSD

Comments

All site improvements including the location of the single family residence and the final grading/landscaping of the site shall strictly adhere to the recommendations outlined in the Geologic Hazards Assessment Report from IGES Project# 01628-013 dated August 3, 2016 (revised July 19, 2017). It is recommended that IGES is present during the excavation of the home site to evaluate the site specific soil conditions which will allow IGES to make any necessary modifications to the recommendations outlined in the report if differing conditions are encountered during excavation. Prior to receiving the final occupancy, a Natural Hazards Notice (to be provided by Weber County) must be recorded with the Weber County Recorder's office per LUC #104-27-5.

Land Use Permit

Structure Setback Graphic: New Dwelling, Addition, Etc.

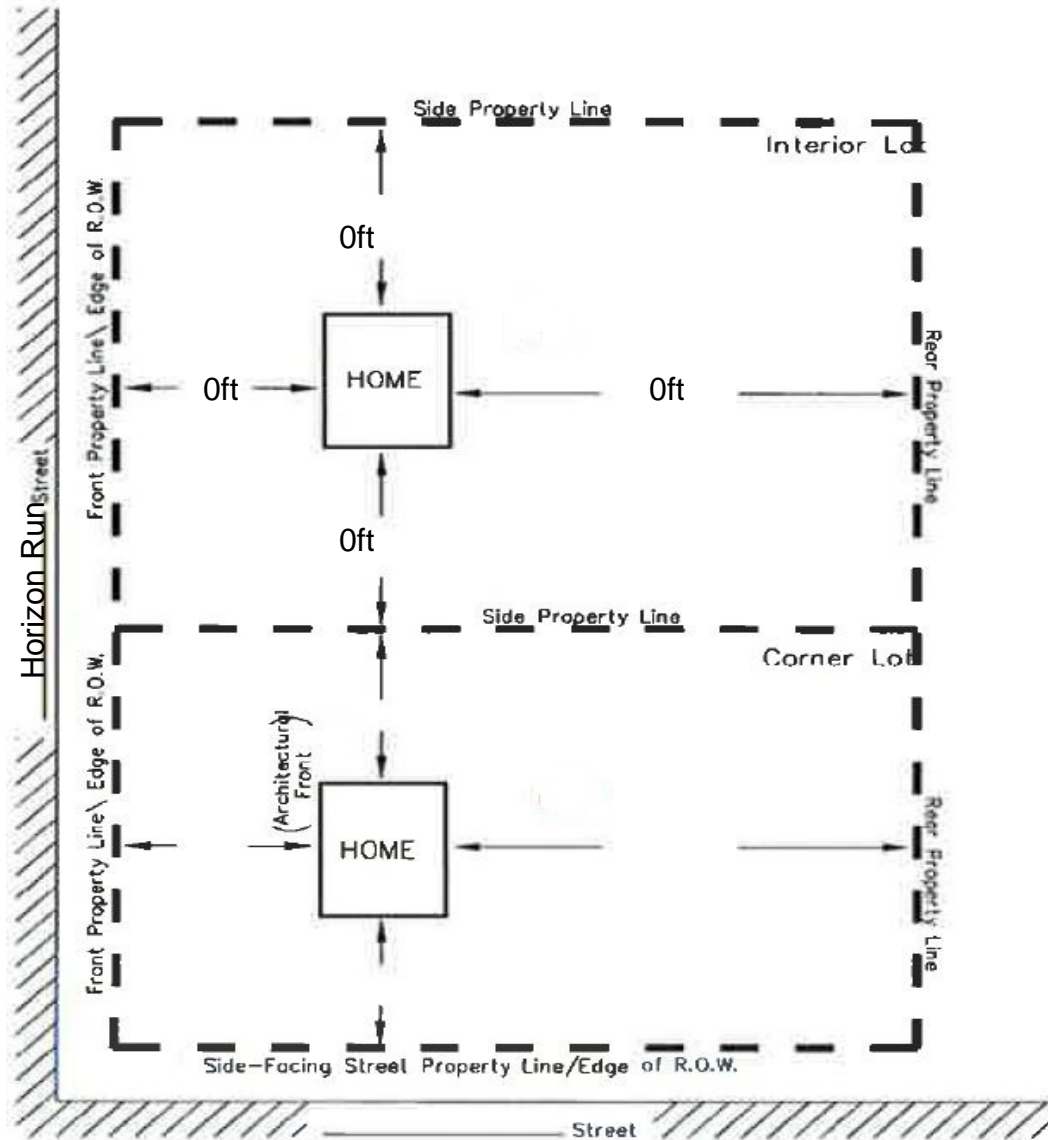

MINIMUM YARD SETBACKS New Dwelling, Addition, Etc.

NOTICE FOR APPLICANT (Please Read Before Signing)

Proposals for the installation of an individual water supply and for a sanitary waste disposal system (septic tank) for any structure designed for human occupation must be approved by Weber County Health Department prior to installation.

Ronda Kippen

08/14/2017

Planning Dept. Signature of Approval

Date

I hereby certify that I have read and examined this application and know the same to be true and correct. All provisions of laws and ordinances governing this land use will be complied with whether specified herein or not. I make this statement under penalty of perjury.

Contractor/Owner Signature of Approval

Date