

# **STORMWATER POLLUTION PREVENTION PLAN FOR CONSTRUCTION**

**Prepared for:**

**Yehuda Residence  
8528 E Spring Park Rd.  
Eden, Weber County, Utah 84310**

**July, 2017**

**Prepared by:**



Planners · Engineers · Surveyors

**Consulting Engineers and Surveyors, Inc.**  
3302 N. Main St, Spanish Fork, UT 84660  
(801)798-0555

# **Storm Water Pollution Prevention Plan**

## **for:**

**Yehuda Residence  
8528 E Spring Park Rd.  
Eden, Weber County, Utah 84310**

## **Owner(s):**

**Yehuda PowMow LLC  
Ron and Navit Yehuda  
322 W 5<sup>th</sup> St. Apt. 172  
New York City, New York 10019**

## **SWPPP Contact(s):**

**Bruce Anderson  
7103 S Redwood Road Suite 426  
West Jordan, UT 84084  
801.910.7614**

## **SWPPP Preparation Date:**

*7/25/17*

### *Estimated Project Dates:*

**Project Start Date: August 1, 2017  
Project Completion Date: August 1, 2018**

## Contents

---

<b>SECTION 1: CONTACT INFORMATION/ RESPONSIBLE PARTIES .....</b>	<b>1</b>
1.1 Owner(s), Operator, Contractors .....	1
1.2 Storm Water Team .....	2
<b>SECTION 2: SITE EVALUATION, ASSESSMENT, &amp; PLANNING .....</b>	<b>3</b>
2.1 Project/Site Information .....	3
2.2 Nature of Construction Activity .....	3
2.3 Construction Site Estimates .....	4
2.4 Soils, Slopes, Vegetation, and Current Drainage Patterns .....	4
2.5 Emergency Related Projects .....	5
2.6 Phase/Sequence of Construction Activity .....	5
2.7 Site Features and Sensitive Areas to be Protected .....	5
2.8 Maps .....	5
<b>SECTION 3: WATER QUALITY .....</b>	<b>6</b>
3.1 UIC Class 5 Injection Wells .....	6
3.2 Discharge Information .....	6
3.3 Receiving Waters .....	6
3.4 Impaired Waters .....	6
3.5 High Water Quality .....	7
3.6 Dewatering Practices .....	7
3.7 Control Storm Water Flowing onto and through the Project .....	7
3.8 Protect Storm Drain Inlets .....	7
<b>SECTION 4: POLLUTION PREVENTION STANDARDS .....</b>	<b>9</b>
4.1 Potential Sources of Pollution .....	9
4.2 Non-Storm Water Discharges .....	9
4.3 Natural Buffers or Equivalent Sediment Controls .....	10
<b>SECTION 5: EROSION AND SEDIMENT CONTROLS .....</b>	<b>11</b>
5.1 Minimize Disturbed Area and Protect Natural Features and Soil .....	11
5.2 Establish Perimeter Controls and Sediment Barriers .....	11
5.3 Retain Sediment On-Site .....	12
5.4 Establish Stabilized Construction Exits .....	12
5.5 Protect Slopes .....	12
5.6 Stockpiled Soil or Other Erodible Material .....	13
5.7 Minimize Dust .....	13
5.8 Topsoil .....	13
5.9 Soil Compaction .....	13
5.10 High Altitude/Heavy Snows .....	13
5.11 Linear Activities .....	13
5.12 Chemical Treatment .....	14
5.13 Stabilize Soils .....	14
5.14 Final Stabilization .....	14
<b>SECTION 6: POLLUTION PREVENTION .....</b>	<b>15</b>
6.1 Spill Prevention and Response .....	15
6.2 Construction and Domestic Waste .....	19

6.3	Washing of Applicators and Containers used for Concrete, Paint or Other Materials.....	20
6.4	Establish Proper Building Material Staging Areas .....	20
6.5	Establish Proper Equipment/Vehicle Fueling and Maintenance Practices.....	20
6.6	Control Equipment/Vehicle Washing .....	21
6.7	Pesticides, Herbicides, Insecticides, Fertilizers, and Landscape Materials .....	21
6.8	Other Pollution Prevention Practices .....	21
<b>SECTION 7: INSPECTIONS &amp; CORRECTIVE ACTIONS .....</b>		<b>23</b>
7.1	Inspections .....	23
7.2	Corrective Actions .....	23
7.3	Delegation of Authority .....	24
<b>SECTION 8: TRAINING AND RECORDKEEPING .....</b>		<b>25</b>
8.1	Training .....	25
8.2	Recordkeeping .....	26
8.3	Log of Changes to the SWPPP .....	26
<b>SECTION 9: CERTIFICATION.....</b>		<b>27</b>
<b>SWPPP APPENDICES .....</b>		<b>28</b>
Appendix A – General Location Map/Site Maps		
Appendix B – Construction General Permit & MS4 Ordinance		
Appendix C – NOI and Acknowledgement Letter from State and MS4		
Appendix D – Inspection Reports		
Appendix E – Corrective Action Log (or in Part 5.3)		
Appendix F – SWPPP Amendment Log (or in Part 6.2)		
Appendix G – Subcontractor Certifications/Agreements		
Appendix H – Grading and Stabilization Activities Log (or in Part 6.1)		
Appendix I – Training Log		
Appendix J – Delegation of Authority		
Appendix K – Additional Information (i.e., Endangered Species and Historic Preservation Documentation; other permits such as dewatering, stream alteration, wetland; and out of date SWPPP documents)		
Appendix L – BMP Specifications		

## **SECTION 1: CONTACT INFORMATION/ RESPONSIBLE PARTIES**

### **1.1 Owner(s), Operator, Contractors**

**Owner(s):**

Ron and Navit Yehuda  
322 W. 5<sup>th</sup> St. Apt. 172  
New York City, NY 10019

**Operator(s):**

Same as Owner

**Project Manager(s) & Site Supervisor(s):**

Ray Bertoldi  
2726 Harrison Boulevard  
Ogden, UT 84403  
801.476.4330  
rbertoldi@bertoldiarchitects.com

**SWPPP Contact(s):**

Bruce Anderson  
7103 S Redwood Road Suite 426  
West Jordan, UT 84084  
801.910.7614  
bruce@bluewillowbuilders.com

**This SWPPP was Prepared by:**

LEI Consulting Engineers and Surveyors  
David Michelsen  
3302 North Main Street  
Spanish Fork, Utah 84660  
(801) 798-0555 Office

**Subcontractor(s):**

Blue Willow Builders  
Bruce Anderson  
7103 S Redwood Road Suite 426  
West Jordan, UT 84084  
801.910.7614  
bruce@bluewillowbuilders.com

**Emergency 24-Hour Contact:**

Bruce Anderson  
801.910.7614

**1.2 Storm Water Team**

Bruce Anderson  
801.910.7614

## SECTION 2: SITE EVALUATION, ASSESSMENT, & PLANNING

### 2.1 Project/Site Information

Project/Site Name: Yehuda Residence

Project Street/Location: 8528 E Spring Park Road

City: Eden State: Utah ZIP Code: 84310

County or Similar Subdivision: Weber County

Latitude/Longitude (Use **one** of three possible formats, and specify method)

Latitude:

Longitude:

1. 41° 22' 11.43" N (degrees, minutes, seconds)

1. 111° 45' 19.08" W (degrees, minutes, seconds)

Method for determining latitude/longitude:

USGS topographic map (specify scale: \_\_\_\_\_)  EPA Web site  GPS

Other (please specify): Google Earth

Is the project located in Indian country?  Yes  No

If yes, name of Reservation, or if not part of a Reservation, indicate "not applicable." \_\_\_\_\_

Not Applicable

Is this project considered a federal facility?  Yes  No

UPDES project or permit tracking number\*: \_\_\_\_\_

*\*(This is the unique identifying number assigned to your project by your permitting authority after you have applied for coverage under the appropriate National Pollutant Discharge Elimination System (UPDES) construction general permit.)*

### 2.2 Nature of Construction Activity

Describe the general scope of the work for the project, major phases of construction, etc:

This project will consist of the construction of 1 residential lot. Included will be the construction of a house and grading of the lot. Existing sewer and water will be connected to the proposed building.

What is the function of the construction activity?

Residential  Commercial  Industrial  Road Construction  Linear Utility

Other (please specify):

Estimated Project Start Date: August 1, 2017

Estimated Project Completion Date: August 1, 2018

### **2.3 Construction Site Estimates**

The following are estimates of the construction site.

Total project area:	0.72 acres
Construction site area to be disturbed:	0.72 acres
Percentage impervious area before construction:	0.00%
Runoff coefficient before construction:	0.10
Percentage impervious area after construction:	43.92%
Runoff coefficient after construction	0.43

### **2.4 Soils, Slopes, Vegetation, and Current Drainage Patterns**

Soil type(s):

The site consists of Herd-Yence complex. These two types of soil are mostly composed of cobbly clay loam, and very stony loam. The water table appears to be more than 80 inches deep. This data was obtained from the USDA Web Soil Survey site.

Slopes (describe current slopes and note any changes due to grading or fill activities):

The site currently has an overall slope of approximately 9-11% to the west.

Drainage Patterns (describe current drainage patterns and note any changes dues to grading or fill activities):

Currently the property drains to the west. Storm runoff will be routed to the roadway and carried to a retention basin downstream.

Vegetation:

Vegetation on the site consists of native grasses and weeds.

Other:



## **2.5 Emergency Related Projects**

Emergency-Related Project?  Yes  No

## **2.6 Phase/Sequence of Construction Activity**

This project is to be completed in a single phase.

- 1 new residential lot will be constructed.
- Construction will begin around August 1, 2017 and be completed around August 1, 2018.
- Best Management Practices (BMP's) associated with construction include:
  - Preserve Natural Vegetation
  - Stabilized Construction Entrance
  - Wheel Wash
  - Grading Practices
  - Temporary and Permanent Seeding
  - Dust Control
  - Straw Wattle
  - Concrete Waste Management
  - Material Delivery, Storage, & Containment
  - Portable Toilets
  - Storm Drain Inlet Protection
  - Silt Fence

## **2.7 Site Features and Sensitive Areas to be Protected**

This project has no historic sites on or near the construction site as determined by the National Register of Historic Places.

There are no endangered species or critical habitats on or near the project site as well as determined by the State of Utah's Federally Listed Endangered Species. There are wetland areas adjacent to the construction site, but these areas are not within the building site, and will not be disturbed during construction.

## **2.8 Maps**

Refer to the site maps in Appendix A.

## SECTION 3: WATER QUALITY

### 3.1 UIC Class 5 Injection Wells

N/A

### 3.2 Discharge Information

Does your project/site discharge storm water into a Municipal Separate Storm Sewer System (MS4)?  Yes  No

List the MS4 that receives the discharge from the construction project:

Are there any surface waters that are located within 50 feet of your construction disturbances?

Yes  No

List the water body: N/A

### 3.3 Receiving Waters

**Table 1 – Names of Receiving Waters** (see <http://wq.deq.utah.gov>)

Name(s) of the first surface water that receives storm water directly from your site and/or from the MS4. (note: multiple rows provided where your site has more than one point of discharge that flows to different surface waters)
1.
2.
3.
4.
5.
6.

### 3.4 Impaired Waters

**Table 2. - Impaired Waters** (Answer the following for each surface water listed in Table 1 above) (see <http://wq.deq.utah.gov> look in the bottom half of the left hand column)

	Is this surface water listed as "impaired"?	If you answered yes, then answer the following:		
		What pollutant(s) are causing the impairment?	Has a TMDL been completed?	Pollutant(s) for which there is a TMDL
1.	<input type="checkbox"/> Yes <input checked="" type="checkbox"/> No		<input type="checkbox"/> Yes <input checked="" type="checkbox"/> No	
2.	<input type="checkbox"/> Yes <input type="checkbox"/> No		<input type="checkbox"/> Yes <input type="checkbox"/> No	
3.	<input type="checkbox"/> Yes <input type="checkbox"/> No		<input type="checkbox"/> Yes <input type="checkbox"/> No	
4.	<input type="checkbox"/> Yes <input type="checkbox"/> No		<input type="checkbox"/> Yes <input type="checkbox"/> No	
5.	<input type="checkbox"/> Yes <input type="checkbox"/> No		<input type="checkbox"/> Yes <input type="checkbox"/> No	
6.	<input type="checkbox"/> Yes <input type="checkbox"/> No		<input type="checkbox"/> Yes <input type="checkbox"/> No	

### 3.5 High Water Quality

**Table 3 – High Water Quality** (Answer the following for each surface water listed in Table 1 above)  
(see <http://wq.deq.utah.gov> look in the bottom half of the left hand column)

	Is this surface water designated as High Water Quality? (see Appendix C)	If you answered yes, specify which category the surface water is designated as?
1.	<input type="checkbox"/> Yes <input checked="" type="checkbox"/> No	<input type="checkbox"/> Category 1 <input type="checkbox"/> Category 2
2.	<input type="checkbox"/> Yes <input type="checkbox"/> No	<input type="checkbox"/> Category 1 <input type="checkbox"/> Category 2
3.	<input type="checkbox"/> Yes <input type="checkbox"/> No	<input type="checkbox"/> Category 1 <input type="checkbox"/> Category 2
4.	<input type="checkbox"/> Yes <input type="checkbox"/> No	<input type="checkbox"/> Category 1 <input type="checkbox"/> Category 2
5.	<input type="checkbox"/> Yes <input type="checkbox"/> No	<input type="checkbox"/> Category 1 <input type="checkbox"/> Category 2
6.	<input type="checkbox"/> Yes <input type="checkbox"/> No	<input type="checkbox"/> Category 1 <input type="checkbox"/> Category 2

### 3.6 Dewatering Practices

It is not anticipated that any dewatering will be required at this site.

### 3.7 Control Storm Water Flowing onto and through the Project

It is anticipated that storm water will flow through this project, due to the steepness of the site. If erosion becomes visible from storm water the following BMPs can be implemented to reduce erosion from concentrated flows.

---

**BMP Description: C254 Straw Wattle**

---

<b>Installation Schedule:</b>	As needed. Beginning of construction or grading through completion of site improvements.
<b>Maintenance and Inspection:</b>	Repair damaged wattles immediately. Remove sediment that breaches the top of the wattle. Inspect daily during rainy periods. Check for undercutting and end runs. Remove accumulated sediment when one half the barrier height.
<b>Responsible Staff:</b>	Bruce Anderson 801.910.7614

### 3.8 Protect Storm Drain Inlets

The purpose is to prevent coarse sediment from entering drainage systems prior to permanent stabilization of the disturbed area. This site will utilize catch basin and curb inlet filters to provide protection. Protection will be provided for all storm drain inlets downstream and within 500 feet of a disturbed or construction area, unless the runoff that enters the catch basin will be conveyed to a sediment pond or trap. Inlet protection will be used anywhere to protect the drainage system. Any storm drain inlet downstream from the site will need to be protected until construction is complete.

---

***BMP Description: C220 Storm Drain Inlet Protection***

---

<b><i>Installation Schedule:</i></b>	Commencement of grading through completion of site improvements.
<b><i>Maintenance and Inspection:</i></b>	Replace clogged filter fabric before bag is over 50% full of sediment. Clean sediment from stone filters. Do not wash collected sediments into storm drains – remove to soil stockpile. Bi-weekly maintenance schedule or as needed.
<b><i>Responsible Staff:</i></b>	Bruce Anderson 801.910.7614

## **SECTION 4: POLLUTION PREVENTION STANDARDS**

### **4.1 Potential Sources of Pollution**

Potential sources of sediment to storm water runoff:

The entire lot under construction is a potential sediment source to storm water runoff. During construction, the necessary requirements will be taken in order to ensure that all sediment in storm water runoff is captured before exiting property.

Potential pollutants and sources, other than sediment, to storm water runoff:

<b>Trade Name Material</b>	<b>Storm Water Pollutants</b>	<b>Location</b>
Petroleum	Fuel, oil and grease	Motorized equipment, vehicles and other equipment
Hard surface compounds	Asphalt and concrete	Excess from driveways, sidewalks and roadways
Acids	Lime adhesives, points, solvents, and curing compounds	Subcontractors aiding in the building of the structure and exterior site work
Human waste	Sanitary waste	All personnel aiding in the building of the structure and exterior site work
Soil	Soil and associated material	Soils, motorized and other equipment
Solid waste	Wood, brick and other material	All personnel aiding in building of the structure with excess materials

### **4.2 Non-Storm Water Discharges**

The following is a list of allowable non-storm water discharges. They are as follows:

1. Water used to wash vehicles where detergents are not used.
2. Water used to control dust.
3. Potable water including uncontaminated water line flushing.
4. Routine external building wash down that does not use detergents.
5. Pavement wash waters where spills or leaks of toxic or hazardous materials have not occurred and where detergents are not used.
6. Uncontaminated air conditioning or compressor condensate.
7. Uncontaminated ground water or spring water.
8. Foundation or footing drains where flows are not contaminated with process materials such as solvents.
9. Uncontaminated excavation dewatering.
10. Landscape irrigation.

Out of these, it is expected that numbers 1 – 5 will be found on the site. These types of non-storm water discharges shall be used sparingly and only as needed. Any use of the discharges listed

above will follow the standards listed in this report in order to contain and prevent them from becoming contaminated.

### **4.3 *Natural Buffers or Equivalent Sediment Controls***

#### **Buffer Compliance Alternatives**

Are there any surface waters within 50 feet of your project's earth disturbances?  YES  
 NO

## **SECTION 5: EROSION AND SEDIMENT CONTROLS**

### **5.1 Minimize Disturbed Area and Protect Natural Features and Soil**

The purpose of preserving natural vegetation is to reduce erosion wherever practicable. Limiting site disturbance is the single most effective method for reducing erosion.

There are currently no natural features located within the disturbed area which need to be protected during construction activity. Therefore, no methods of protection will be implemented.

Topsoil shall be stockpiled in a location where it does not interfere with work on site and so that it meets specifications. Silt fence is to be placed around the base of the stockpile in order to ensure soil does not erode and contaminate adjacent areas.

### **5.2 Establish Perimeter Controls and Sediment Barriers**

The use of a silt fence reduces the transport of coarse sediment from a construction site by providing a temporary physical barrier to sediment and reducing the runoff velocities of overland flow. The silt fence will be placed along the perimeter of the lot as shown on the site map in Appendix A. The minimum height of the top of silt fence shall be two feet and the maximum height shall be two and half feet above the original ground surface. The geotextile at the bottom of the fence shall be buried in a trench to a minimum depth of 4 inches below the ground surface. The trench shall be backfilled and the soil tamped in place over the buried portion of the geotextile, such that no flow can pass beneath the fence and scouring cannot occur. Silt fences shall be located on contour as much as possible, except at the ends of the fence, where the fence shall be turned uphill such that the silt fence captures the runoff water and prevents water from flowing around the end of the fence.

The following is a list of BMP's specifically assigned to this particular site.

<b><i>BMP Description: C233 Silt Fence</i></b>	
<input type="checkbox"/> <b><i>Permanent</i></b>	<input checked="" type="checkbox"/> <b><i>Temporary</i></b>
<b><i>Installation Schedule:</i></b>	Commencement of grading through completion of site improvements.
<b><i>Maintenance and Inspection:</i></b>	Repair damaged fencing immediately. Intercept concentrated flows and reroute. Remove sediment accumulations at 6-inches. Replace deteriorated fencing material. Properly dispose of used fencing. Bi-weekly maintenance schedule or as needed.
<b><i>Responsible Staff:</i></b>	Bruce Anderson 801.910.7614

### 5.3 Retain Sediment On-Site

With the aid of sediment barriers and the established perimeter controls as described above, all sediment should be retained on-site.

### 5.4 Establish Stabilized Construction Exits

Construction entrances are stabilized to reduce the amount of sediment transported onto paved roads by vehicles or equipment by constructing a stabilized pad of course aggregate at entrances to construction sites. A stabilized construction entrance and exit will be placed at the approximate location of the proposed entrance. Integrated within this entrance, when necessary, will be a wheel wash to be used when the site is damp and muddy and the soil clings to the tires.

The following is a list of BMP's specifically assigned to this particular site.

---

***BMP Description: C105 Stabilized Construction Entrance***

<input type="checkbox"/> <b><i>Permanent</i></b>		<input checked="" type="checkbox"/> <b><i>Temporary</i></b>	
<b><i>Installation Schedule:</i></b>		Beginning of construction or grading through completion of site improvements.	
<b><i>Maintenance and Inspection:</i></b>		Aggregate shall be added if the pad is no longer in accordance with the specifications. If the entrance is not working to keep streets clean, then install wheel wash, sweep streets, or wash streets if wash water can be collected. Bi-weekly maintenance schedule or as needed.	
<b><i>Responsible Staff:</i></b>		Bruce Anderson 801.910.7614	

---

***BMP Description: C106 Wheel Wash***

<input type="checkbox"/> <b><i>Permanent</i></b>		<input checked="" type="checkbox"/> <b><i>Temporary</i></b>	
<b><i>Installation Schedule:</i></b>		Beginning of construction or grading through completion of site improvements.	
<b><i>Maintenance and Inspection:</i></b>		Wheel wash water shall not be discharged into a storm drain or the site's storm water collection system. Use closed-loop recirculation or land application. Bi-weekly maintenance schedule or as needed.	
<b><i>Responsible Staff:</i></b>		Bruce Anderson 801.910.7614	

### 5.5 Protect Slopes

The existing site has slopes between 9% and 11%. Straw wattles will be placed along the natural contours of the land, where necessary, until permanent vegetation or improvements are put into place.

The following is a list of BMP's specifically assigned to this particular site.



***BMP Description: C254 Straw Wattle***

<input type="checkbox"/> <b><i>Permanent</i></b>	<input checked="" type="checkbox"/> <b><i>Temporary</i></b>
<b><i>Installation Schedule:</i></b>	As needed. Beginning of construction or grading through completion of site improvements.
<b><i>Maintenance and Inspection:</i></b>	Repair damaged wattles immediately. Remove sediment that breaches the top of the wattle. Inspect daily during rainy periods. Check for undercutting and end runs. Remove accumulated sediment when one half the barrier height.
<b><i>Responsible Staff:</i></b>	Bruce Anderson 801.910.7614

**5.6 Stockpiled Soil or Other Erodible Material**

Stockpiled soil should have a silt fence placed along the bottom of the pile on the downhill side in order to stop the flow of any sediment. See the BMP in section 5.2 for silt fence description.

**5.7 Minimize Dust**

It is likely that spraying the disturbed areas with water will be the only required dust control measure needed. Refer to Appendix K for the Fugitive Dust Control plan per State requirements.

***BMP Description: C140 Dust Control***

<b><i>Installation Schedule:</i></b>	Once soil is disturbed
<b><i>Maintenance and Inspection:</i></b>	Spray disturbed soil with water to prevent the blowing of dust during construction activities.
<b><i>Responsible Staff:</i></b>	Bruce Anderson 801.910.7614

**5.8 Topsoil**

Topsoil shall be stockpiled in a location where it does not interfere with work on site and so that it meets specifications. Silt fence is to be placed around the base of the stockpile in order to ensure soil does not erode and contaminate adjacent areas. See Section 5.6.

**5.9 Soil Compaction**

Any area that is not to be improved at this time will be protected from disturbance in order to lessen the chance of causing erosion. In areas that are planned to be landscaped, the soil will be re-worked before final landscaping so as to encourage infiltration and avoid compaction.

**5.10 High Altitude/Heavy Snows**

High altitude heavy snow is expected for this site.

**5.11 Linear Activities**

Not Applicable

### 5.12 Chemical Treatment

It is not anticipated that chemical treatments will be required.

### 5.13 Stabilize Soils

There will be no use of interim soil stabilization during the construction of the site improvements. All disturbed areas will be stabilized at the end with completion of the project. Hydroseeding or sod may be used in addition to the landscaping plans and will be determined by the contractor at the end of construction.

### 5.14 Final Stabilization

Final stabilization will be done at the end of construction. Following are some BMPs for portions of the landscaping. Refer to Appendix A for a Landscape Plan serving as a stabilization map.

---

***BMP Description: C120 Permanent Seeding***

<input checked="" type="checkbox"/> <b><i>Permanent</i></b>	<input type="checkbox"/> <b><i>Temporary</i></b>
<b><i>Installation Schedule:</i></b>	Following completion of building and final grading.
<b><i>Maintenance and Inspection:</i></b>	Re-seed areas failing to establish 80% cover within one month (during growing season). If re-seeding is ineffective, use sodding or nets/blankets. Eroded areas shall be corrected, re-planted, and irrigated as required.
<b><i>Responsible Staff:</i></b>	Bruce Anderson 801.910.7614

---

***BMP Description: C124 Sodding***

<input checked="" type="checkbox"/> <b><i>Permanent</i></b>	<input type="checkbox"/> <b><i>Temporary</i></b>
<b><i>Installation Schedule:</i></b>	Following completion of building and final grading.
<b><i>Maintenance and Inspection:</i></b>	If sod is unhealthy correct problem. If sod can't be established seed area and use net or blanket to stabilize soils.
<b><i>Responsible Staff:</i></b>	Bruce Anderson 801.910.7614

## **SECTION 6: POLLUTION PREVENTION**

### **6.1 Spill Prevention and Response**

Consistent with the general permit requirements, all potential pollutants other than sediment will be handled and disposed of in a manner that does not cause contamination of storm water. The following is a table of possible hazardous materials with their reportable quantities if reached:

<b>Hazardous Material</b>	<b>Location of Spill</b>	<b>Reportable Quantity</b>
Oils, brake fluid	Land/Water	25 gallons or visible sheen
Refrigerant	Air	1 lb.
Antifreeze	Land/Water	13 gallons
Battery Acid	Land/Water	100 lbs.
Engine Degreaser Products	Land/Water	100 lbs.
Gasoline	Land/Water	5 gallons
Diesel Fuel	Land/Water	10 gallons

Other non-sediment pollutants which must be monitored that may be present during construction activities include:

- Polymer used for soil stabilization
- Water treatment chemicals (coagulant, acid, sodium bicarbonate)
- Concrete
- Paints
- Fertilizers

These materials, and other materials used during construction with the potential to impact storm water, will be stored, managed, used, and disposed of in a manner that minimizes the potential for releases to the environment and especially into storm water.

Each work area should have a spill response kit. Most of the spills can be cleaned up following the manufacturer's recommendation. Absorbent/oil dry, sealable containers, plastic bags, and shovels/brooms are suggested minimum spill response items that should be on this location.

#### **Spill Response Plan**

When a spill from a hazardous source occurs, the following items should be addressed:

- 1<sup>st</sup> Priority: Protect all people
- 2<sup>nd</sup> Priority: Protect equipment and property
- 3<sup>rd</sup> Priority: Protect the environment.

The following steps should be taken if a spill occurs on site:

1. Make sure the spill area is safe to enter and that it does not pose an immediate threat to health or safety of any person.
2. Stop the spill source.
3. Check for hazards (flammable material, noxious fumes, cause of spill) – if flammable liquid, turn off engines and nearby electrical equipment. If serious hazards are present, leave area and call 911. **LARGE SPILLS ARE LIKELY TO PRESENT A HAZARD.**
4. Call co-workers and supervisor for assistance and to make them aware of the spill and potential dangers.
5. If possible, stop spill from entering drains (use absorbent or other material as necessary).
6. Stop spill from spreading (use absorbent or other material).
7. If spilled material has entered a storm sewer; contact the local Storm Water Department.
8. Clean up spilled material according to manufacturer specifications, for liquid spills use absorbent materials and do not flush area with water.
9. Properly dispose of cleaning materials and used absorbent material according to manufacturer specifications.

Emergency contacts for the project should be contacted if a spill occurs in excess of the reportable quantity listed above. Below is a list of emergency contacts:

### **EMERGENCY NUMBERS**

Utah Division of Water Quality	801.538.6146
Utah Hazmat Response Officer 24-Hrs.	801.538.3745
Weber Fire District Station 62	801.745.3420
Ogden City Police Department	801.395.8221
Staff Contact – Bruce Anderson	801.910.7614

### **General Materials Handling Practices**

The following general practices will be used throughout the project to reduce the potential for spills.

- Potential pollutants will be stored and used in a manner consistent with the manufacturer’s instructions in a secure location. To the extent practicable, material storage areas should not be located near storm drain inlets and should be equipped with covers, roofs, or secondary containment as needed to prevent storm water from contacting stored materials. Chemicals that are not compatible (such as sodium bicarbonate and hydrochloric acid) shall be stored in segregated areas so that spilled materials cannot combine and react.
- Materials disposal will be in accordance with the manufacturer’s instructions and applicable local, state, and federal regulations.

- Materials no longer required for construction will be removed from the site as soon as practicable.
- Adequate garbage, construction waste, and sanitary waste handling and disposal facilities will be provided to the extent necessary to keep the site clear of obstruction and BMPs clear and functional.

### **Specific Materials Handling Practices**

- All pollutants, including waste materials and demolition debris, that occur on-site during construction will be handled in a way that does not contaminate storm water.
- All chemicals including liquid products, petroleum products, water treatment chemicals, and wastes stored on site will be covered and contained and protected from vandalism.
- Maintenance and repair of all equipment and vehicles involving oil changes, hydraulic system drain down, de-greasing operations, fuel tank drain down and removal, and other activities which may result in the accidental release of contaminants, will be conducted under cover during wet weather and on an impervious surface to prevent the release of contaminants into the ground. Materials spilled during maintenance operations will be cleaned up immediately and properly disposed of.
- Wheel wash water will be settled and discharged on site by infiltration. Wheel wash water will not be discharged to the storm water system or the storm water treatment system.
- Application of agricultural chemicals, including fertilizers and pesticides, will be conducted in a manner and at application rates that will not result in loss of chemical to storm water runoff. Manufacturers' recommendations will be followed for application rates and procedures.
- pH-modifying sources will be managed to prevent contamination of runoff and storm water collected on site. The most common sources of pH-modifying materials are bulk cement, cement kiln dust (CKD), fly ash, new concrete washing and curing waters, waste streams generated from concrete grinding and sawing, exposed aggregate processes, and concrete pumping and mixer washout waters.
- A centralized Concrete Waste Management area will be provided for all on-site construction activities.

### **Spill Response**

The primary objective in responding to a spill is to quickly contain the material(s) and prevent or minimize their migration into storm water runoff and conveyance systems. If the release has impacted on-site storm water, it is critical to contain the released materials on site and prevent their release into receiving waters.

If a spill of pollutants threatens storm water at the site, the spill response procedures outlined below must be implemented in a timely manner to prevent the release of pollutants.

- The site superintendent will be notified immediately when a spill, or the threat of a spill, is observed. The superintendent will assess the situation and determine the appropriate response.
- If spills represent an imminent threat of escaping facilities and entering the receiving waters, facility personnel will respond immediately to contain the release and notify the superintendent after the situation has been stabilized.
- Spill kits containing materials and equipment for spill response and cleanup will be readily available to the site.
- If oil sheen is observed on surface water (e.g., settling ponds, detention pond, swales), absorbent pads and/or booms will be applied to contain and remove the oil. The source of the oil sheen will also be identified and removed or repaired as necessary to prevent further releases.
- The site superintendent, or his designee, will be responsible for completing the spill reporting form and for reporting the spill to the appropriate state or local agency.
- Spill response equipment will be inspected and maintained as necessary to replace any materials used in spill response activities.

### **Notification**

In the event of a spill, make the appropriate notification(s) consistent with the following procedures:

- Any spill of oil which 1) violates water quality standards, 2) produces a “sheen” on a surface water, or 3) causes a sludge or emulsion must be reported immediately by telephone to the site superintendent at the phone numbers listed at the beginning of this document.
- Any oil, hazardous substance, or hazardous waste release which exceeds the reportable quantity must be reported immediately by telephone to the site superintendent at the phone numbers listed at the beginning of the document.

Any discharges in 24 hours equal to or in excess of the reportable quantities listed in 40 CFR 117, 40 CFR 110, and 40 CFR 302 will be reported to the National Response Center and the Division of Water Quality (DWQ) as soon as practical after knowledge of the spill is known to the permittees. The permittee shall submit within 14 calendar days of knowledge of the release a written description of: the release (including the type and estimate of the amount of material released), the date that such release occurred, the circumstances leading to the release, and measures taken and/or planned to be taken to the Division of Water Quality (DWQ), 288 North

1460 West, P.O. Box 144870, Salt Lake City, Utah 84114-4870. The Storm Water Pollution Prevention Plan must be modified within 14 calendar days of knowledge of the release to provide a description of the release, the circumstances leading to the release, and the date of the release. In addition, the plan must be reviewed to identify measures to prevent the reoccurrence of such releases and to respond to such releases, and the plan must be modified where appropriate.

<b>Agency</b>	<b>Phone Number</b>
National Response Center	(800) 424-8802
Division of Water Quality ( DWQ) 24-Hr Reporting	(801) 538-6146 (801) 536-4123
Utah Department of Health Emergency Response	(801) 580-6681

<b>Material</b>	<b>Media Released To</b>	<b>Reportable Quantity</b>
Engine oil, fuel, hydraulic & brake fluid	Land	25 gallons
Paints, solvents, thinners	Land	100 lbs (13 gallons)
Engine oil, fuel, hydraulic & brake fluid	Water	Visible Sheen
Antifreeze, battery acid, gasoline, engine degreasers	Air, Land, Water	100 lbs (13 gallons)
Refrigerant	Air	1 lb

## **6.2 Construction and Domestic Waste**

Each of the pollutants listed in the following sections will be handled and stored in their designated areas by creating cleanout areas, placing trash receptacles, providing portable toilets, and installing secondary containment areas where required. Each of these areas will be strategically placed throughout the site in places where material can be controlled and maintained.

### 6.3 **Washing of Applicators and Containers used for Concrete, Paint or Other Materials**

Concrete work can generate process water and slurry that contain fine particles and high pH, both of which can violate water quality standards in the receiving water. These BMP's are intended to minimize and eliminate concrete process water and slurry from entering the storm water system. All wet and dry materials will be stored in a covered place away from drainage areas. The designated concrete cleanout area will be created by installing earthen berms around it to prevent runoff to a drainage box.

---

**BMP Description: C151 Concrete Waste Management**

---

<input type="checkbox"/> <b>Permanent</b>	<input checked="" type="checkbox"/> <b>Temporary</b>
<b>Installation Schedule:</b>	Beginning of construction or grading through completion of site improvements.
<b>Maintenance and Inspection:</b>	Inspect to ensure compliance with concrete waste criteria. Provide on-going training. Bi-weekly maintenance schedule or as needed.
<b>Responsible Staff:</b>	Bruce Anderson 801.910.7614

### 6.4 **Establish Proper Building Material Staging Areas**

Prevent, reduce, or eliminate the discharge of pollutants from material delivery and storage to the storm water system or watercourses by minimizing the storage of hazardous materials onsite, storing materials in a designated area, and installing secondary containment. Possible pollutants include trash disposal, sanitary wastes, recycling, concrete waste and improper material handling.

---

**BMP Description: C153 Material Delivery, Storage and Containment**

---

<input type="checkbox"/> <b>Permanent</b>	<input checked="" type="checkbox"/> <b>Temporary</b>
<b>Installation Schedule:</b>	Beginning of construction or grading through completion of site improvements.
<b>Maintenance and Inspection:</b>	Inspect to ensure compliance with requirements of BMP. Bi-weekly maintenance schedule or as needed.
<b>Responsible Staff:</b>	Bruce Anderson 801.910.7614

### 6.5 **Establish Proper Equipment/Vehicle Fueling and Maintenance Practices**

Prevent or reduce impacts to storm water due to fuel spills, fuel leaks and discharge of pollutants from vehicle and equipment cleaning by the use of off-site facilities, performing activities in designated and controlled areas only and training of employees and subcontractors. Sending vehicles / equipment off-site should be done in conjunction with the stabilized construction entrance.



The on-site SWPPP Supervisor shall ensure that all sub-contractors are aware of the design and installation specifications, locations and spill prevention practices applicable to these tasks. All spills and problems should be cleaned and removed immediately.

The following is a list of BMP's specifically assigned to this particular site. Information is included referencing sequencing, maintenance, inspection procedures, and responsible staff. Specific design specifications and details can be found in Appendix L.

***BMP Description: C155 Vehicle Equipment Fueling / Cleaning***

<input type="checkbox"/> <b><i>Permanent</i></b>		<input checked="" type="checkbox"/> <b><i>Temporary</i></b>	
<b><i>Installation Schedule:</i></b>	Beginning of construction or grading through completion of site improvements.		
<b><i>Maintenance and Inspection:</i></b>	Inspect to ensure compliance with requirements of BMP. Provide on-going training.		
<b><i>Responsible Staff:</i></b>	Bruce Anderson 801.910.7614		

**6.6 Control Equipment/Vehicle Washing**

All equipment/vehicle washing practices shall take place within the stabilized construction entrance incorporated with the wheel washing. All equipment/vehicles with soil or other materials which need to be removed must be cleaned and inspected as necessary before leaving the site. Any type of vehicle washing shall take place within designated wash areas to be determined by the on-site SWPPP Supervisor.

**6.7 Pesticides, Herbicides, Insecticides, Fertilizers, and Landscape Materials**

It is not anticipated that any fertilizers will be used during construction.

**6.8 Other Pollution Prevention Practices**

Here are additional BMP's which do not fit in the categories listed above but may be needed under special circumstances.

***BMP Description: C108 Grading Practices***

<b><i>Installation Schedule:</i></b>	As needed. Beginning of construction or grading through completion of site improvements.
<b><i>Maintenance and Inspection:</i></b>	Inspect graded areas to determine if proper grading practices are being followed. Bi-weekly maintenance schedule or as needed.
<b><i>Responsible Staff:</i></b>	Bruce Anderson 801.910.7614

***BMP Description: C121 Mulching***

<b><i>Installation Schedule:</i></b>	As needed. Beginning of construction or grading through completion of site improvements.
<b><i>Maintenance and Inspection:</i></b>	Maintain specified thickness of mulch cover. Eroded areas must be corrected and re-mulched. Drainage problems must be corrected. Bi-weekly maintenance schedule or as needed.
<b><i>Responsible Staff:</i></b>	Bruce Anderson 801.910.7614

***BMP Description: C190 Portable Toilets***

<input type="checkbox"/> <b><i>Permanent</i></b>	<input checked="" type="checkbox"/> <b><i>Temporary</i></b>
<b><i>Installation Schedule:</i></b>	Beginning of construction or grading through completion of site improvements.
<b><i>Maintenance and Inspection:</i></b>	Inspect for compliance to location, perimeter berm and continual service by licensed provider. Bi-weekly maintenance schedule or as needed.
<b><i>Responsible Staff:</i></b>	Bruce Anderson 801.910.7614

## **SECTION 7: INSPECTIONS & CORRECTIVE ACTIONS**

### **7.1 Inspections**

**1. Inspection Personnel:** Identify the person(s) who will be responsible for conducting inspections and describe their qualifications:

Inspector: Bruce Anderson      Qualifications: Check those that apply:

- Utah Registered Storm Water Inspector (RSI)
- Certified Professional in Erosion and Sediment Control (CPESC)
- Certified Professional in Storm Water Quality (CPSWQ)
- Certified Erosion, Sediment, and Storm Water Inspector (CESSWI)
- Certified Inspector of Sediment and Erosion Control (CISEC)
- National Institute for Certification in Engineering Technologies, Erosion and Sediment Control, Level 3 (NICET)
- Utah Department of Transportation Erosion Control Supervisor (ECS)

**2. Inspection Schedule and Procedures:**

Inspections will be done on a bi-weekly schedule at minimum. In addition, inspections will be conducted within 24 hours of a rain event of 0.5” or more. For a multi-day event, inspections will be conducted within 24 hours of the first 0.5” and within 24 hours of the end of the rain event.

Describe the general procedures for correcting problems when they are identified. Include responsible staff and time frames for making corrections:

See Section 6 above.

See Appendix D for a copy of the inspection forms, including a visual inspection form.

### **7.2 Corrective Actions**

Corrective Action Log:

See Appendix E

### **7.3 Delegation of Authority**

**Duly Authorized Representative(s) or Position(s):**

Blue Willow Builders  
Bruce Anderson  
SWPPP Contact  
7103 S Redwood Road Suite 426  
West Jordan, UT 84084  
801.910.7614

See Appendix J for an attached copy of the signed delegation of authority form.

## **SECTION 8: TRAINING AND RECORDKEEPING**

### **8.1 Training**

Individual(s) Responsible for Training:

- 1.
- 2.
- 3.
- 4.
- 5.

Describe Training Conducted:

- General stormwater and BMP awareness training for staff and subcontractors:
  - 1.
  - 2.
  - 3.
  - 4.
  - 5.
- Detailed training for staff and subcontractors with specific stormwater responsibilities:
  - 1.
  - 2.
  - 3.
  - 4.
  - 5.

<b>Training Attendee Name</b>	<b>Title of Training</b>	<b>Duration</b>	<b>Date of Training</b>

Additional training documentation should be included in Appendix J.

## **8.2 Recordkeeping**

Appendix H contains a log form which references dates at which grading, construction activity, and stabilization occurs on the site. The form should be filled out and placed within the section along with a copy of the construction general permit, signed and certified NOI form, copy of letter from the EPA, inspection reports, and any other specific details.

Records will be retained for a minimum period of at least 3 years after the permit is terminated.

Date(s) when major grading activities occur:

- 1.
- 2.
- 3.
- 4.
- 5.

Date(s) when construction activities temporarily or permanently cease on a portion of the site:

- 1.
- 2.
- 3.
- 4.
- 5.

Date(s) when an area is either temporarily or permanently stabilized:

- 1.
- 2.
- 3.
- 4.
- 5.

## **8.3 Log of Changes to the SWPPP**

Log of changes and updates to the SWPPP

See Appendix F

## SECTION 9: CERTIFICATION

### Owner

I certify under penalty of law that this document and all attachments were prepared under my direction or supervision in accordance with a system designed to assure that qualified personnel properly gathered and evaluated the information submitted. Based on my inquiry of the person or persons who manage the system, or those persons directly responsible for gathering the information, the information submitted is, to the best of my knowledge and belief, true, accurate, and complete. I am aware that there are significant penalties for submitting false information, including the possibility of fine and imprisonment for knowing violations.

Name: Ron Yehuda Title: Owner

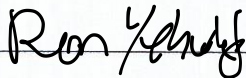
Signature:  Date: 8/1/17

### General Contractor

I certify under penalty of law that this document and all attachments were prepared under my direction or supervision in accordance with a system designed to assure that qualified personnel properly gathered and evaluated the information submitted. Based on my inquiry of the person or persons who manage the system, or those persons directly responsible for gathering the information, the information submitted is, to the best of my knowledge and belief, true, accurate, and complete. I am aware that there are significant penalties for submitting false information, including the possibility of fine and imprisonment for knowing violations.

Name: BRUCE D. ANDERSON Title: PRES.

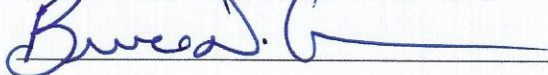
Signature:  Date: 7/29/17

## **SWPPP APPENDICES**

***Appendix A – General Location Map/ Site Maps***

***Appendix B – Construction General Permit***

***Appendix C – NOI and Acknowledgement Letter from  
EPA/State/MS4***

***Appendix D – Inspection Reports***

***Appendix E – Corrective Action Log (see CGP 5.4)***

***Appendix F – SWPPP Amendment Log (see CGP 7.4.3)***

***Appendix G – Subcontractor Certifications/Agreements***

***Appendix H – Grading and Stabilization Activities Log (see CGP  
7.2.4.b)***

***Appendix I – Training Log (see CGP 6)***

***Appendix J – Delegation of Authority (see CGP Appendix  
G16.1.2)***

***Appendix K – Additional Information (i.e., Other permits such as  
dewatering, stream alteration, wetland; and out of  
date swppp documents)***

***Appendix L – BMP Specifications***



**Appendix A**  
**General Location / Site Maps**

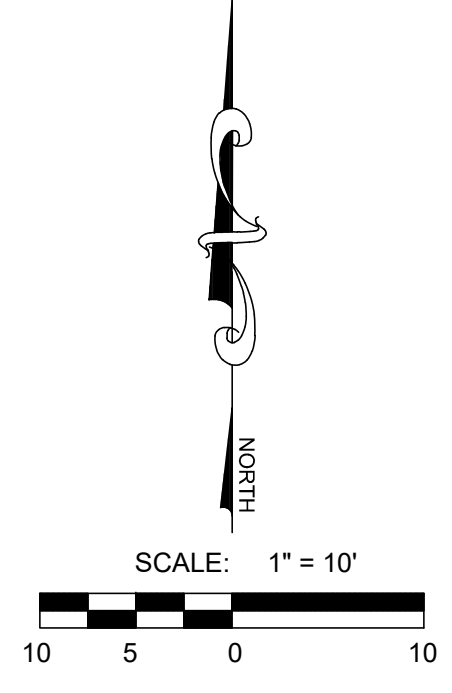

NOT FOR CONSTRUCTION

**YEHUDA RESIDENCE**  
 8528 E SPRING PARK DR, EDEN, WEBER COUNTY, UTAH  
 APPENDIX A  
 EROSION CONTROL PLAN



CONSTRUCTION PHASE STORM WATER POLLUTION PROTECTION PLAN BEST MANAGEMENT PRACTICES (BMP)					
QTY	BMP#	BMP SYMBOL	TITLE	LOCATION	DURATION
-	C101	(101)	PRESERVING NATURAL VEGETATION	AS SHOWN	COMMENCEMENT OF GRADING THROUGH COMPLETION OF SITE IMPROVEMENTS
-	C103	(103)	PLASTIC OR METAL FENCE	AS SHOWN	COMMENCEMENT OF GRADING THROUGH COMPLETION OF SITE IMPROVEMENTS
-	C105	(105)	STABILIZED CONSTRUCTION ENTRANCE	AS SHOWN	BEGINNING OF CONSTRUCTION THROUGH COMPLETION OF SITE IMPROVEMENTS
-	C106	(106)	WHEEL WASH	AS NECESSARY	BEGINNING OF CONSTRUCTION THROUGH COMPLETION OF SITE IMPROVEMENTS
-	C190	(190)	PORTABLE TOILETS	AS SHOWN	BEGINNING OF CONSTRUCTION THROUGH COMPLETION OF SITE IMPROVEMENTS
-	C140	(140)	DUST CONTROL	PER CONTRACTOR	BEGINNING OF CONSTRUCTION THROUGH COMPLETION OF SITE IMPROVEMENTS
-	C151	(151)	CONCRETE WASTE MANAGEMENT	PER CONTRACTOR / AS SHOWN	BEGINNING OF CONSTRUCTION THROUGH COMPLETION OF SITE IMPROVEMENTS
-	C220	(220)	STORM DRAIN INLET PROTECTION	AS SHOWN	COMMENCEMENT OF GRADING THROUGH COMPLETION OF SITE IMPROVEMENTS
-	C233	(233)	SILT FENCE	PER CONTRACTOR/ AS SHOWN	COMMENCEMENT OF GRADING THROUGH COMPLETION OF SITE IMPROVEMENTS

**LEGEND**

- LIMITS OF DISTURBANCE
- SILT FENCE
- CONCRETE WASTE MGMT.
- STABILIZED CONSTRUCTION ENTRANCE
- PRESERVE EXISTING VEGETATION
- PORTABLE TOILETS
- FLOW ARROW

**PRESERVATION OF EXISTING VEGETATION**

- CLEARLY MARK, FLAG OR FENCE VEGETATION OR AREAS WHERE VEGETATION SHOULD BE PRESERVED.
- PREPARE LANDSCAPING PLANS WHICH INCLUDE AS MUCH EXISTING VEGETATION AS POSSIBLE AND STATE PROPER CARE DURING AND AFTER CONSTRUCTION.
- DEFINE AND PROTECT WITH BERMS, FENCING, SIGNS, ETC. A SETBACK AREA FROM VEGETATION TO BE PRESERVED.
- PROPOSE LANDSCAPE PLANS WHICH DO NOT INCLUDE PLANT SPECIES THAT COMPETE WITH EXISTING VEGETATION.
- DO NOT LOCATE CONSTRUCTION TRAFFIC ROUTES, SPOIL PILES, ETC. WHERE SIGNIFICANT ADVERSE IMPACT ON EXISTING VEGETATION MAY OCCUR.

**NOTES**

1. REFER TO SWPPP BINDER FOR DETAILS OF BMP'S.
2. CONTRACTOR TO ADD ADDITIONAL BMP'S AS NECESSARY BASED ON SITE CONDITIONS.
3. EXISTING AND PROPOSED GRADING AS SHOWN ON THIS PLAN WAS PROVIDED BY OTHERS. ANY DESIGN ISSUES SHALL BE ADDRESSED WITH SITE DESIGNERS.

REVISIONS
1 -
2 -
3 -
4 -
5 -
6 -

LEI PROJECT #:  
**2017-0000**  
 DRAWN BY:  
**DPM**  
 CHECKED BY:  
**BCT**  
 SCALE:  
**1" = 10'**  
 DATE:  
**07/25/2017**

C:\USERS\BALE\DRAWING\PROJECTS\SWPPP\YEHUDA RESIDENCE - EROSION CONTROL PLAN.DWG 7/25/2017 2:48 PM

**Appendix B**  
**Construction General Permit**

## **Appendix C**

### **NOI and Acknowledgement Letter from EPA / State / MS4**

**Appendix D**  
**Inspection Reports**



	BMP	BMP Installed?	BMP Maintenance Required?	Corrective Action Needed and Notes
12		<input type="checkbox"/> Yes <input type="checkbox"/> No	<input type="checkbox"/> Yes <input type="checkbox"/> No	
13		<input type="checkbox"/> Yes <input type="checkbox"/> No	<input type="checkbox"/> Yes <input type="checkbox"/> No	
14		<input type="checkbox"/> Yes <input type="checkbox"/> No	<input type="checkbox"/> Yes <input type="checkbox"/> No	
15		<input type="checkbox"/> Yes <input type="checkbox"/> No	<input type="checkbox"/> Yes <input type="checkbox"/> No	
16		<input type="checkbox"/> Yes <input type="checkbox"/> No	<input type="checkbox"/> Yes <input type="checkbox"/> No	
17		<input type="checkbox"/> Yes <input type="checkbox"/> No	<input type="checkbox"/> Yes <input type="checkbox"/> No	
18		<input type="checkbox"/> Yes <input type="checkbox"/> No	<input type="checkbox"/> Yes <input type="checkbox"/> No	
19		<input type="checkbox"/> Yes <input type="checkbox"/> No	<input type="checkbox"/> Yes <input type="checkbox"/> No	
20		<input type="checkbox"/> Yes <input type="checkbox"/> No	<input type="checkbox"/> Yes <input type="checkbox"/> No	

### Overall Site Issues

*Below are some general site issues that should be assessed during inspections. Customize this list as needed for conditions at your site.*

	BMP/activity	Implemented?	Maintenance Required?	Corrective Action Needed and Notes
1	Are all slopes and disturbed areas not actively being worked properly stabilized?	<input type="checkbox"/> Yes <input type="checkbox"/> No	<input type="checkbox"/> Yes <input type="checkbox"/> No	
2	Are natural resource areas (e.g., streams, wetlands, mature trees, etc.) protected with barriers or similar BMPs?	<input type="checkbox"/> Yes <input type="checkbox"/> No	<input type="checkbox"/> Yes <input type="checkbox"/> No	
3	Are perimeter controls and sediment barriers adequately installed (keyed into substrate) and maintained?	<input type="checkbox"/> Yes <input type="checkbox"/> No	<input type="checkbox"/> Yes <input type="checkbox"/> No	
4	Are discharge points and receiving waters free of any sediment deposits?	<input type="checkbox"/> Yes <input type="checkbox"/> No	<input type="checkbox"/> Yes <input type="checkbox"/> No	
5	Are storm drain inlets properly protected?	<input type="checkbox"/> Yes <input type="checkbox"/> No	<input type="checkbox"/> Yes <input type="checkbox"/> No	
6	Is the construction exit preventing sediment from being tracked into the street?	<input type="checkbox"/> Yes <input type="checkbox"/> No	<input type="checkbox"/> Yes <input type="checkbox"/> No	
7	Is trash/litter from work areas collected and placed in covered dumpsters?	<input type="checkbox"/> Yes <input type="checkbox"/> No	<input type="checkbox"/> Yes <input type="checkbox"/> No	

	<b>BMP/activity</b>	<b>Implemented?</b>	<b>Maintenance Required?</b>	<b>Corrective Action Needed and Notes</b>
8	Are washout facilities (e.g., paint, stucco, concrete) available, clearly marked, and maintained?	<input type="checkbox"/> Yes <input type="checkbox"/> No	<input type="checkbox"/> Yes <input type="checkbox"/> No	
9	Are vehicle and equipment fueling, cleaning, and maintenance areas free of spills, leaks, or any other deleterious material?	<input type="checkbox"/> Yes <input type="checkbox"/> No	<input type="checkbox"/> Yes <input type="checkbox"/> No	
10	Are materials that are potential stormwater contaminants stored inside or under cover?	<input type="checkbox"/> Yes <input type="checkbox"/> No	<input type="checkbox"/> Yes <input type="checkbox"/> No	
11	Are non-stormwater discharges (e.g., wash water, dewatering) properly controlled?	<input type="checkbox"/> Yes <input type="checkbox"/> No	<input type="checkbox"/> Yes <input type="checkbox"/> No	
12	Visually inspect all discharges. Are all discharges approved as per the requirements set forth in this report?	<input type="checkbox"/> Yes <input type="checkbox"/> No	<input type="checkbox"/> Yes <input type="checkbox"/> No	
13	(Other)	<input type="checkbox"/> Yes <input type="checkbox"/> No	<input type="checkbox"/> Yes <input type="checkbox"/> No	

**Non-Compliance**

Describe any incidents of non-compliance not described above:
---

**CERTIFICATION STATEMENT**

“I certify under penalty of law that this document and all attachments were prepared under my direction or supervision in accordance with a system designed to assure that qualified personnel properly gathered and evaluated the information submitted. Based on my inquiry of the person or persons who manage the system, or those persons directly responsible for gathering the information, the information submitted is, to the best of my knowledge and belief, true, accurate, and complete. I am aware that there are significant penalties for submitting false information, including the possibility of fine and imprisonment for knowing violations.”

**Print name and title:** \_\_\_\_\_

**Signature:** \_\_\_\_\_ **Date:** \_\_\_\_\_



**Appendix E**  
**Corrective Action Log**



**Appendix F**  
**SWPPP Ammendment Log**



**Appendix G**  
**Subcontractor Certifications / Agreements**

# Appendix G –Subcontractor Certifications/Agreements

## SUBCONTRACTOR CERTIFICATION STORMWATER POLLUTION PREVENTION PLAN

Project Number: \_\_\_\_\_

Project Title: \_\_\_\_\_

Operator(s): \_\_\_\_\_

As a subcontractor, you are required to comply with the Stormwater Pollution Prevention Plan (SWPPP) for any work that you perform on-site. Any person or group who violates any condition of the SWPPP may be subject to substantial penalties or loss of contract. You are encouraged to advise each of your employees working on this project of the requirements of the SWPPP. A copy of the SWPPP is available for your review at the office trailer.

Each subcontractor engaged in activities at the construction site that could impact stormwater must be identified and sign the following certification statement:

**I certify under the penalty of law that I have read and understand the terms and conditions of the SWPPP for the above designated project and agree to follow the BMPs and practices described in the SWPPP.**

This certification is hereby signed in reference to the above named project:

Company: \_\_\_\_\_

Address: \_\_\_\_\_

Telephone Number: \_\_\_\_\_

Type of construction service to be provided: \_\_\_\_\_

\_\_\_\_\_  
\_\_\_\_\_

Signature: \_\_\_\_\_

Title: \_\_\_\_\_

Date: \_\_\_\_\_

**Appendix H**  
**Grading and Stabilization Activities Log**





**Appendix I**  
**Training Log**

# Appendix I –SWPPP Training Log

## Stormwater Pollution Prevention Training Log

Project Name:

Project Location:

Instructor's Name(s):

Instructor's Title(s):

Course Location: \_\_\_\_\_ Date: \_\_\_\_\_

Course Length (hours): \_\_\_\_\_

Stormwater Training Topic: *(check as appropriate)*

- Erosion Control BMPs
- Emergency Procedures
- Sediment Control BMPs
- Good Housekeeping BMPs
- Non-Stormwater BMPs

Specific Training Objective: \_\_\_\_\_

Attendee Roster: *(attach additional pages as necessary)*

No.	Name of Attendee	Company
1		
2		
3		
4		
5		
6		
7		
8		
9		
10		

**Appendix J**  
**Delegation of Authority**

# Appendix J –Delegation of Authority Form

## Delegation of Authority

I, \_\_\_\_\_ (name), hereby designate the person or specifically described position below to be a duly authorized representative for the purpose of overseeing compliance with environmental requirements, including the Construction General Permit, at the YEHUDA RESIDENCE construction site. The designee is authorized to sign any reports, stormwater pollution prevention plans and all other documents required by the permit.

\_\_\_\_\_ (name of person or position)  
\_\_\_\_\_ (company)  
\_\_\_\_\_ (address)  
\_\_\_\_\_ (city, state, zip)  
\_\_\_\_\_ (phone)

By signing this authorization, I confirm that I meet the requirements to make such a designation as set forth in \_\_\_\_\_ (Reference State Permit), and that the designee above meets the definition of a “duly authorized representative” as set forth in \_\_\_\_\_ (Reference State Permit).

I certify under penalty of law that this document and all attachments were prepared under my direction or supervision in accordance with a system designed to assure that qualified personnel properly gathered and evaluated the information submitted. Based on my inquiry of the person or persons who manage the system, or those persons directly responsible for gathering the information, the information submitted is, to the best of my knowledge and belief, true, accurate, and complete. I am aware that there are significant penalties for submitting false information, including the possibility of fine and imprisonment for knowing violations.

**Name:** \_\_\_\_\_

**Company:** \_\_\_\_\_

**Title:** \_\_\_\_\_

**Signature:** \_\_\_\_\_

**Date:** \_\_\_\_\_

## **Appendix K**

**Additional Information (i.e. documentation; other permits such as dewatering, stream alteration, wetland; and out of date swppp documents)**

**Appendix L**  
**BMP Specifications**

# **BMP C105: STABILIZED CONSTRUCTION ENTRANCE**

## *Purpose*

Construction entrances are stabilized to reduce the amount of sediment transported onto paved roads by vehicles or equipment by constructing a stabilized pad of course aggregate at entrances to construction sites.

## *Conditions of Use*

Construction entrances shall be stabilized wherever traffic will be leaving a construction site and traveling on paved roads or other paved areas within 1,000 feet of the site.

## *Design and Installation Specifications*

- See Figure for details.
- A separation geotextile shall be placed under the aggregate to prevent fine sediment from pumping up into the rock pad. The geotextile shall meet the following standards:

Grab Tensile Strength (ASTM D4751)	200 psi min.
Grab Tensile Elongation (ASTM D4632)	30% max.
Mullen Burst Strength (ASTM D3786-80a)	400 psi min.
AOS (ASTM D4751)	20-45 (U.S. standard sieve size)

- Consider early installation of the first lift of asphalt in areas that will be paved; this can be used as a stabilized entrance. Also consider the installation of excess concrete as a stabilized entrance. During large concrete pours, excess concrete is often available for this purpose.
- Fencing (see BMP C103) shall be installed as necessary to restrict traffic to the construction entrance.
- Whenever possible, the entrance shall be constructed on a firm, compacted subgrade. This can substantially increase the effectiveness of the pad and reduce the need for maintenance.

## *Maintenance Standards*

- Additional aggregate shall be added if the pad is no longer in accordance with the specifications.
- If the entrance is not preventing sediment from being tracked onto pavement, then alternative measures to keep the streets free of sediment shall be used. This may

include street sweeping, an increase in the dimensions of the entrance, or the installation of a wheel wash.

- Any sediment that is tracked onto pavement shall be removed by shoveling or street sweeping. The sediment collected by sweeping shall be removed or stabilized on site. The pavement shall not be cleaned by washing down the street, except when sweeping is ineffective and there is a threat to public safety. If it is necessary to wash the streets, the construction of a small sump shall be considered. The sediment would then be washed into the sump where it can be controlled.
- Any aggregate that is loosened from the pad, which end up on the roadway shall be removed immediately.
- If vehicles are entering or exiting the site at points other than the construction entrance(s), fencing (see BMP C103) shall be installed to control traffic.
- Upon project completion and site stabilization, all construction accesses intended as permanent access for maintenance shall be permanently stabilized.

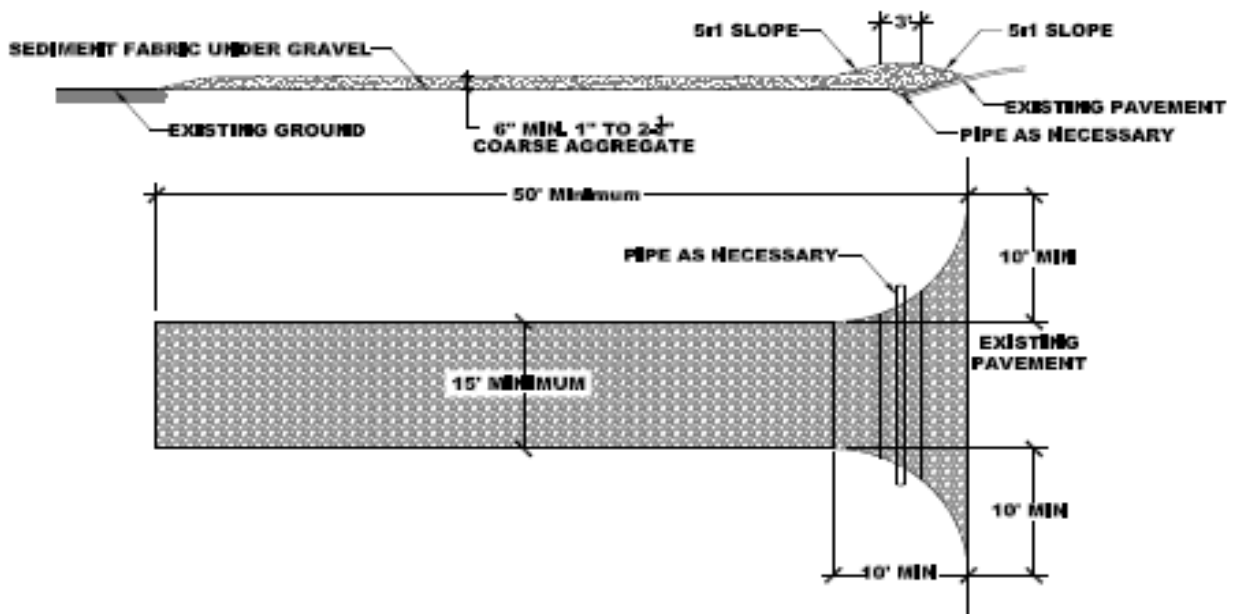

**STABILIZED CONSTRUCTION ENTRANCE SHALL BE MAINTAINED UNTIL SUCH TIME AS ROADS ARE ASPHALTED AND INDIVIDUAL HOME LOTS ARE BEING DEVELOPED.**



## **BMP C106: WHEEL WASH**

### ***Purpose***

Wheel washes reduce the amount of sediment transported onto paved roads by motor vehicles.

### ***Conditions of Use***

When a stabilized construction entrance (see BMP C105) is not preventing sediment from being tracked onto pavement, a wheel wash is to be used.

- Wheel washing is generally an effective BMP when installed with careful attention to topography. For example, a wheel wash can be detrimental if installed at the top of a slope abutting a right-of-way where the water from the dripping truck can run unimpeded into the street.
- Pressure washing combined with an adequately sized and surfaced pad with direct drainage to a large 10-foot x 10-foot sump can be very effective.

### ***Design and Installation Specifications***

Suggested details are shown in the Figure. A minimum of 6 inches of asphalt treated base (ATB) over crushed base material or 8 inches over a good subgrade is recommended to pave the wheel wash.

Use a low clearance truck to test the wheel wash before paving. Either a belly dump or lowboy will work well to test clearance.

Keep the water level from 12 to 14 inches deep to avoid damage to truck hubs and filling the truck tongues with water.

Midpoint spray nozzles are only needed in extremely muddy conditions.

Wheel wash systems should be designed with a small grade change, 6 to 12 inches for a 10-foot-wide pond, to allow sediment to flow to the low side of pond to help prevent re-suspension of sediment. A drainpipe with a 2- to 3-foot riser should be installed on the low side of the pond to allow for easy cleaning and refilling. Polymers may be used to promote coagulation and flocculation in a closed-loop system. Polyacrylamide (PAM) added to the wheel wash water at a rate of 0.25 - 0.5 pounds per 1,000 gallons of water increases effectiveness and reduces cleanup time.

### ***Maintenance Standards***

The wheel wash should start out the day with fresh water.

The wash water should be changed a minimum of once per day. On large earthwork jobs where more than 10-20 trucks per hour are expected, the wash water will need to be changed more often.

Wheel wash or tire bath wastewater shall be discharged to a separate onsite treatment system, such as closed-loop recirculation or land application, or to the sanitary sewer with proper local sewer district approval.

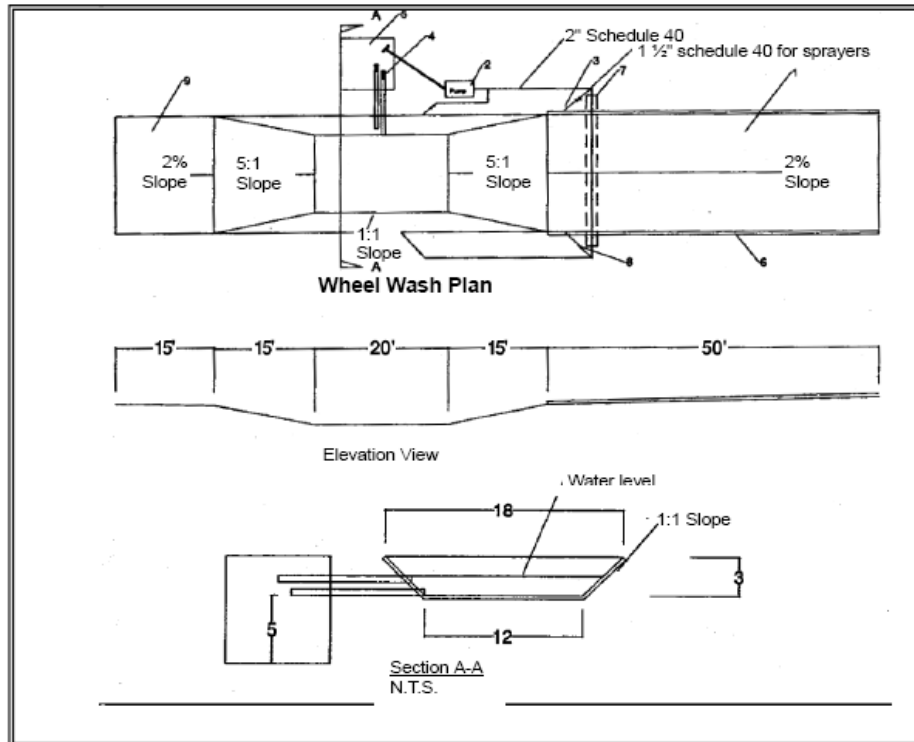

Notes:

1. Asphalt construction entrance 6 in. asphalt treated base (ATB).
2. 3-inch trash pump with floats on the suction hose.
3. Midpoint spray nozzles, if needed.
4. 6-inch sewer pipe with butterfly valves. Bottom one is a drain. Locate top pipe's invert 1 foot above bottom of wheel wash.
5. 8 foot x 8 foot sump with 5 feet of catch. Build so can be cleaned with trackhoe.
6. Asphalt curb on the low road side to direct water back to pond.
7. 6-inch sleeve under road.
8. Ball valves.
9. 15 foot. ATB apron to protect ground from splashing water.

## **BMP C108: GRADING PRACTICES**

### *Purpose*

Control soil erosion by minimizing the exposure of bare soil to erosive forces. This is done by:

- Limiting the amount of land disturbed at one time in preparation for construction.
- Limiting the amount of time between the disturbance of soil and protection or stabilization of disturbed soils, and
- Using grading practices to protect exposed soils susceptible to storm water runoff.

Related practices include preservation of existing vegetation, erosion control practices and sediment control practices.

### *Conditions of Use*

- The specific approach to grading on a particular site depends on the conditions of the site and surrounding land; engineering judgment is required to design the approach best suited for each site.

### *Design and Installation Specifications*

- Limit the area of disturbance to those areas requiring grading. This preserves existing vegetation and reduces the vulnerability of soil to erosion.
- Based on erosion potential and sediment control measures on the site, establish what areas are to be graded at one time.
- An undisturbed buffer zone containing vegetation at the lowest elevation of a construction site can reduce the transport of sediment offsite.
- Initiate soil protection measures during the course of work to minimize the length of time soil is exposed to erosive forces.
- Conduct work in stages so that construction or soil stabilization occurs promptly after disturbance of soil.
- Establish a schedule governing the stabilization of disturbed slopes, both in terms of passage of time since commencement and completion of disturbance and in terms of planting season.

- Leaving the surface of the disturbed soil graded in a roughened condition (not smooth) can reduce the quantity and velocity of storm water runoff.
- Prevent storm water runoff from running onto steep slopes from above.
- Avoid long, steep cut or fill slopes that allow runoff water of sufficient quantity or velocity to cut into and erode the slope.

#### ***Maintenance Standards***

- Practices may need to vary from the approved plan if erosion problems appear when storm water runoff occurs.

## **BMP C120: TEMPORARY AND PERMANENT SEEDING**

### *Purpose*

Seeding is intended to reduce erosion by stabilizing exposed soils. A well-established vegetative cover is one of the most effective methods of reducing erosion.

### *Conditions of Use*

- Seeding may be used throughout the project on disturbed areas that have reached final grade or that will remain unworked for more than 90 days.
- Channels that will be vegetated should be installed before major earthwork and hydroseeded with a Bonded Fiber Matrix. The vegetation should be well established (i.e., 75 percent cover) before water is allowed to flow in the ditch. With channels that will have high flows, erosion control blankets should be installed over the hydroseed. If vegetation cannot be established from seed before water is allowed in the ditch, sod should be installed in the bottom of the ditch over hydromulch and blankets.
- Retention/detention ponds should be seeded as required.
- Mulch is required at all times because it protects seeds from heat, moisture loss, and transport due to runoff.
- All disturbed areas shall be reviewed in late August to early September and all seeding should be completed by the end of September.
- At final site stabilization, all disturbed areas not otherwise vegetated or stabilized shall be seeded and mulched. Final stabilization means the completion of all soil disturbing activities at the site and the establishment of a permanent vegetative cover, or equivalent permanent stabilization measures (such as pavement, riprap, gabions or geotextiles) which will prevent erosion.

### *Design and Installation Specifications*

- Seeding should be done during those seasons most conducive to growth.
- To prevent seed from being washed away, confirm that all required surface water control measures have been installed.
- The seedbed should be firm and rough. All soil should be roughened no matter what the slope. If compaction is required for engineering purposes, slopes must be track walked before seeding. Backblading or smoothing of slopes greater than 4:1 is not allowed if they are to be seeded.

- Hydroseed applications shall include a minimum of 1,500 pounds per acre of mulch with 3 percent tackifier.
- Mulch is always required for seeding. Mulch can be applied on top of the seed or simultaneously by hydroseeding.
- On steep slopes, Bonded Fiber Matrix (BFM) or Mechanically Bonded Fiber Matrix (MBFM) products should be used.
- All seed mixes to consist of local grasses and plants which will blend with undisturbed areas of the project.

### *Maintenance Standards*

- Any seeded areas that fail to establish at least 80 percent cover shall be reseeded. If reseeding is ineffective, an alternate method, such as sodding, mulching, or nets/blankets, shall be used.
- After adequate cover is achieved, any areas that experience erosion shall be reseeded and protected by mulch. If the erosion problem is drainage related, the problem shall be fixed and the eroded area reseeded and protected by mulch.
- If necessary, seeded areas shall be supplied with adequate moisture, but not watered to the extent that it causes runoff.

## **BMP C121: MULCHING**

### ***Purpose***

The purpose of mulching soils is to provide immediate temporary protection from erosion. Mulch also enhances plant establishment by conserving moisture, holding fertilizer, seed, and topsoil in place, and moderating soil temperatures. There is an enormous variety of mulches that can be used. Only the most common types are discussed in this section.

### ***Conditions of Use***

As a temporary cover measure, mulch should be used:

- On disturbed areas that require cover measures for less than 30 days.
- As a cover for seed during the wet season and during the hot summer months.
- During the wet season on slopes steeper than 3H:1V with more than 10 feet of vertical relief.
- Mulch may be applied at any time of the year and must be refreshed periodically.

### ***Design and Installation Specifications***

For mulch materials, application rates, and specifications, see Table 4.7.

Note: Thicknesses may be increased for disturbed areas in or near sensitive areas or other areas highly susceptible to erosion.

Mulch used within the ordinary high-water mark of surface waters should be selected to minimize potential flotation of organic matter. Composted organic materials have higher specific gravities (densities) than straw, wood, or chipped material.

### ***Maintenance Standards***

- The thickness of the cover must be maintained.
- Any areas that experience erosion shall be remulched and/or protected with a net or blanket. If the erosion problem is drainage related, then the problem shall be fixed and the eroded area remulched.

**Table 4.7  
Mulch Standards and Guidelines**

<b>Mulch Material</b>	<b>Quality Standards</b>	<b>Application Rates</b>	<b>Remarks</b>
Straw	Air-dried; free from undesirable seed and coarse material.	2"-3" thick; 5 bales per 1000 sf or 2-3 tons per acre	Cost-effective protection when applied with adequate thickness. Hand-application generally requires greater thickness than blown straw. The thickness of straw may be reduced by half when used in conjunction with seeding. In windy areas straw must be held in place by crimping, using a tackifier, or covering with netting. Blown straw always has to be held in place with a tackifier as even light winds will blow it away. Straw, however, has several deficiencies that should be considered when selecting mulch materials. It often introduces and/or encourages the propagation of weed species and it has no significant long-term benefits. Straw should be used only if mulches with long-term benefits are unavailable locally. It should also not be used within the ordinary high-water elevation of surface waters (due to flotation).
Hydromulch	No growth inhibiting factors.	Approx. 25-30 lbs per 1000 sf or 1500 - 2000 lbs per acre	Shall be applied with hydromulcher. Shall not be used without seed and tackifier unless the application rate is at least doubled. Fibers longer than about ¾-1 inch clog hydromulch equipment. Fibers should be kept to less than ¾ inch.
Composted Mulch and Compost	No visible water or dust during handling. Must be purchased from supplier with Solid Waste Handling Permit (unless exempt).	2" thick min.; approx. 100 tons per acre (approx. 800 lbs per yard)	More effective control can be obtained by increasing thickness to 3". Excellent mulch for protecting final grades until landscaping because it can be directly seeded or tilled into soil as an amendment. Composted mulch has a coarser size gradation than compost. It is more stable and practical to use in wet areas and during rainy weather conditions.
Chipped Site Vegetation	Average size shall be several inches. Gradations from fines to 6 inches in length for texture, variation, and interlocking properties.	2" minimum thickness	This is a cost-effective way to dispose of debris from clearing and grubbing, and it eliminates the problems associated with burning. Generally, it should not be used on slopes above approx. 10% because of its tendency to be transported by runoff. It is not recommended within 200 feet of surface waters. If seeding is expected shortly after mulch, the decomposition of the chipped vegetation may tie up nutrients important to grass establishment.
Wood-based Mulch	No visible water or dust during handling. Must be purchased from a supplier with a Solid Waste Handling Permit or one exempt from solid waste regulations.	2" thick; approx. 100 tons per acre (approx. 800 lbs. per cubic yard)	This material is often called "hog or hogged fuel." It is usable as a material for Stabilized Construction Entrances (BMP C105) and as a mulch. The use of mulch ultimately improves the organic matter in the soil. Special caution is advised regarding the source and composition of wood-based mulches. Its preparation typically does not provide any weed seed control, so evidence of residual vegetation in its composition or known inclusion of weed plants or seeds should be monitored and prevented (or minimized).



## **BMP C124: SODDING**

### ***Purpose***

The purpose of sodding is to establish permanent turf for immediate erosion protection and to stabilize drainage ways where concentrated overland flow will occur.

### ***Conditions of Use***

Sodding may be used in the following areas:

- Disturbed areas that require short-term or long-term cover.
- Disturbed areas that require immediate vegetative cover.
- All waterways that require vegetative lining. Waterways may also be seeded rather than sodded, and protected with a net or blanket.

### ***Design and Installation Specifications***

Sod shall be free of weeds, of uniform thickness (approximately 1-inch thick), and shall have a dense root mat for mechanical strength.

The following steps are recommended for sod installation:

- Shape and smooth the surface to final grade in accordance with the approved grading plan. The swale needs to be over-excavated 4 to 6 inches below design elevation to allow room for placing soil amendment and sod.
- Amend 4 inches (minimum) of compost into the top 8 inches of the soil if the organic content of the soil is less than ten percent or the permeability is less than 0.6 inches per hour. Compost used should meet Ecology publication 94-038 specifications for Grade A quality compost.
- Fertilize according to the supplier's recommendations.
- Work lime and fertilizer 1 to 2 inches into the soil, and smooth the surface.
- Lay strips of sod beginning at the lowest area to be sodded and perpendicular to the direction of water flow. Wedge strips securely into place. Square the ends of each strip to provide for a close, tight fit. Stagger joints at least 12 inches. Staple on slopes steeper than 3H:1V. Staple the upstream edge of each sod strip.

- Roll the sodded area and irrigate.
- When sodding is carried out in alternating strips or other patterns, seed the areas between the sod immediately after sodding.

### ***Maintenance Standards***

If the grass is unhealthy, the cause shall be determined and appropriate action taken to reestablish a healthy groundcover. If it is impossible to establish a healthy groundcover due to frequent saturation, instability, or some other cause, the sod shall be removed, the area seeded with an appropriate mix, and protected with a net or blanket.

## **BMP C140: DUST CONTROL**

### ***Purpose***

Dust control prevents wind transport of dust from disturbed soil surfaces onto roadways, drainage ways, and surface waters.

### ***Conditions for Use***

- In areas (including roadways) subject to surface and air movement of dust where on-site and off-site impacts to roadways, drainage ways, or surface waters are likely

### ***Design and Installation Specifications***

- Limit dust generation by clearing only those areas where immediate activity will take place, leaving the remaining area(s) in the original condition, if stable. Maintain the original ground cover as long as practical.
- Sprinkle the site with water until surface is wet. Repeat as needed.
- Spray exposed soil areas with a dust palliative, following the manufacturer's instructions and cautions regarding handling and application. Used oil is prohibited from use as a dust suppressant. Local governments may approve other dust palliatives such as calcium chloride or PAM.
- PAM (BMP C126) added to water at a rate of 0.5 lbs. per 1,000 gallons of water per acre and applied from a water truck is more effective than water alone.

Techniques that can be used for unpaved roads and lots include:

- Lower speed limits. High vehicle speed increases the amount of dust stirred up from unpaved roads and lots.
- Add surface gravel to reduce the source of dust emission. Limit the amount of fine particles (those smaller than .075 mm) to 10 to 20 percent.
- Encourage the use of alternate, paved routes, if available.
- Restrict use by tracked vehicles and heavy trucks to prevent damage to road surface and base.
- Apply chemical dust suppressants using the admix method, blending the product with the top few inches of surface material. Suppressants may also be applied as surface treatments.

- Use vacuum street sweepers.
- Remove mud and other dirt promptly so it does not dry and then turn into dust.
- Limit dust-causing work on windy days.

*Maintenance Standards*

- Respray area as necessary to keep dust to a minimum.

## **BMP C151: CONCRETE WASTE MANAGEMENT**

### ***Purpose***

Concrete work can generate process water and slurry that contain fine particles and high pH, both of which can violate water quality standards in the receiving water. This BMP is intended to minimize and eliminate concrete process water and slurry from entering the storm water system.

### ***Conditions for Use***

Any time concrete is used, these management practices shall be utilized. Concrete construction projects include, but are not limited to, the following:

- Curbs
- Sidewalks
- Roads
- Bridges
- Foundations
- Floors

### ***Design and Installation Specifications***

- Store wet and dry materials under cover and away from drainage areas.
- Create designated concrete cleanout area by excavation or installing berms according to the detail sheet in Appendix A.
- Avoid mixing excess amounts of fresh concrete on-site.
- Perform washout of concrete trucks off-site or in designated areas only.
- Do not wash out concrete trucks into storm drains, open ditches, streets or vacant properties.
- Do not allow excess concrete to be dumped on-site, except in designated areas.
- When washing concrete to remove fine particles and expose the aggregate, avoid creating runoff by draining the water into a bermed or level area.

- Train employees, contractors and subcontractors in proper concrete waste management.

### ***Maintenance Standards***

- Inspect subcontractors to ensure that concrete wastes are being properly managed.
- If using a temporary pit, dispose hardened concrete on a regular basis.

## **BMP C153: MATERIAL DELIVERY, STORAGE AND CONTAINMENT**

### *Purpose*

Prevent, reduce, or eliminate the discharge of pollutants from material delivery and storage to the stormwater system or watercourses by minimizing the storage of hazardous materials onsite, storing materials in a designated area, and installing secondary containment.

### *Conditions of Use*

**These procedures are suitable for use at all construction sites with delivery and storage of the following materials:**

- Petroleum products such as fuel, oil and grease
- Soil stabilizers and binders (e.g. Polyacrylamide)
- Fertilizers, pesticides and herbicides
- Detergents
- Asphalt and concrete compounds
- Hazardous chemicals such as acids, lime, adhesives, paints, solvents and curing compounds
- Any other material that may be detrimental if released to the environment

### *Design and Installation Specifications*

**The following steps should be taken to minimize risk:**

- Temporary storage area should be located away from vehicular traffic, near the construction entrance(s), and away from waterways or storm drains.
- Material Safety Data Sheets (MSDS) should be supplied for all materials stored. Chemicals should be kept in their original labeled containers.
- Hazardous material storage on-site should be minimized.
- Hazardous materials should be handled as infrequently as possible.

- During the wet weather season (Oct 1 – April 30), consider storing materials in a covered area.
- Materials should be stored in secondary containments, such as earthen dikes.
- Do not store chemicals, drums, or bagged materials directly on the ground. Place these items on a pallet and, when possible, in secondary containment.

#### **Material Storage Areas and Secondary Containment Practices:**

- Liquids, petroleum products, and substances listed in 40 CFR Parts 110, 117, or 302 shall be stored in approved containers and drums and shall not be overfilled. Containers and drums shall be stored in temporary secondary containment facilities.
- Temporary secondary containment facilities shall provide for a spill containment volume able to contain precipitation from a 25 year, 24 hour storm event, plus 10% of the total enclosed container volume of all containers, or 110% of the capacity of the largest container within its boundary, whichever is greater.
- Secondary containment facilities shall be impervious to the materials stored therein for a minimum contact time of 72 hours.
- Sufficient separation should be provided between stored containers to allow for spill cleanup and emergency response access.
- During the wet weather season (Oct 1 – April 30), each secondary containment facility shall be covered during non-working days, prior to and during rain events.
- Keep material storage areas clean, organized and equipped with an ample supply of appropriate spill clean-up material (spill kit).



## **BMP C155: VEHICLE EQUIPMENT FUELING/CLEANING**

### *Purpose*

Prevent or reduce impacts to storm water due to fuel spills, fuel leaks and discharge of pollutants from vehicle and equipment cleaning by the use of off-site facilities, performing activities in designated and controlled areas only and training of employees and subcontractors.

### *Conditions of Use*

- Sending vehicles/equipment off-site should be done in conjunction with Stabilized Construction Entrance.

### *Design and Installation Specifications*

- Use off-site fueling stations and commercial washing facilities as much as possible. Fueling or cleaning vehicles and equipment outdoors or in areas where fuel may spill/leak or wash water flow onto paved surfaces or into drainage pathways can pollute storm water. If you fuel or clean a large number of vehicles or pieces of equipment, consider using off-site stations. These businesses are better equipped to handle fuel, spills and disposal of wash waters properly.
- If fueling must occur on-site, use designated areas, located away from drainage courses, to prevent the runoff of storm water and the runoff of spills. Discourage “topping-off” of fuel tanks.
- Always use secondary containment, such as a drain pan or drop cloth, when fueling to catch spills/leaks. Place a stockpile of spill cleanup materials where it will be readily accessible. Use absorbent materials promptly and dispose of properly.
- Carry out all Federal and State requirements regarding stationary above ground storage tanks. Avoid mobile fueling of mobile construction equipment around the site; rather, transport the equipment to designated fueling areas. With the exception of tracked equipment such as bulldozers and perhaps forklifts, most vehicles should be able to travel to a designated area with little lost time. Train employees and subcontractors in proper fueling and cleanup procedures.
- If washing must occur on-site, use designated, bermed wash areas to prevent wash water contact with storm water, creeks, rivers, and other water bodies. The wash area can be sloped for wash water collection and subsequent infiltration into the ground.
- Use as little water as possible to avoid having to install erosion and sediment controls for the wash area. Use phosphate-free biodegradable soaps. Educate employees and subcontractors on pollution prevention measures. Do not permit steam cleaning on-site. Steam cleaning can generate significant pollutant concentrations.

## **Maintenance Standards**

- Keep ample supplies of spill cleanup materials on-site.
- Inspect fueling areas and storage tanks on a regular schedule.
- Minimal, some berm repair may be necessary.

## **BMP C190: PORTABLE TOILETS**

### *Purpose*

Provide temporary on-site sanitary facilities for construction personnel.

### *Conditions of Use*

- All sites with no permanent sanitary facilities or where permanent facilities are too far from job activities.

### *Design and Installation Specifications*

- Locate portable toilets in convenient locations throughout the site.
- Prepare level, gravel surface and provide clear access to the toilets for servicing and for on-site personnel.
- Construct a minimum 1' high earth berm around the perimeter of the toilet to allow sufficient volume to control spill/leaks.

### **Maintenance Standards**

- Regular inspection and waste collection must be completed by licensed service provider.
- The area below the outlet must be stabilized with a riprap apron or other suitable improvement.
- If the pipe slope drain is conveying sediment-laden water, direct all flows into the sediment trapping facility.

### *Maintenance Standards*

Check inlet and outlet points regularly, especially after storms.

The inlet should be free of undercutting, and no water should be going around the point of entry. If there are problems, the headwall should be reinforced with compacted earth or sand bags.

## **BMP C220: STORM DRAIN INLET PROTECTION**

### *Purpose*

To prevent coarse sediment from entering drainage systems prior to permanent stabilization of the disturbed area.

### *Conditions of Use*

Protection should be provided for all storm drain inlets downslope and within 500 feet of a disturbed or construction area, unless the runoff that enters the catch basin will be conveyed to a sediment pond or trap. Inlet protection may be used anywhere to protect the drainage system. It is likely that the drainage system will still require cleaning.

The following table lists several options for inlet protection. All of the methods for storm drain inlet protection are prone to plugging and require a high frequency of maintenance. Drainage areas should be limited to 1 acre or less. Emergency overflows may be required where stormwater ponding would cause a hazard. If an emergency overflow is provided, additional end-of-pipe treatment may be required.

<b>Storm Drain Inlet Protection</b>			
<b>Type of Inlet Protection</b>	<b>Emergency Overflow</b>	<b>Applicable for Paved/Earthen Surfaces</b>	<b>Conditions of Use</b>
<b>Drop Inlet Protection</b>			
Excavated drop inlet protection	Yes, temporary flooding will Occur	Earthen	Applicable for heavy flows. Easy to maintain. Large area Requirement: 30'x30'/acre
Block and gravel drop inlet protection	Yes	Paved or Earthen	Applicable for heavy concentrated flows. Will not pond.
Gravel and wire drop inlet protection	No		Applicable for heavy concentrated flows. Will pond. Can withstand traffic.
Catch basin and curb inlet filters	Yes	Paved or Earthen	Frequent maintenance required.
<b>Curb Inlet Protection</b>			
Catch basin and curb inlet filters	Yes	Paved or Earthen	Frequent maintenance required.
Curb inlet protection with straw bales or waddle block and gravel	Small capacity overflow	Paved	Used for sturdy, more compact installation.
curb inlet protection	Yes	Paved	Sturdy, but limited filtration.

### *Design and Installation Specifications*

*Excavated Drop Inlet Protection* - An excavated impoundment around the storm drain. Sediment settles out of the stormwater prior to entering the storm drain.

- Depth 1-2 ft as measured from the crest of the inlet structure.
- Side Slopes of excavation no steeper than 2:1.
- Minimum volume of excavation 35 cubic yards.
- Shape basin to fit site with longest dimension oriented toward the longest inflow area.
- Install provisions for draining to prevent standing water problems.
- Clear the area of all debris.
- Grade the approach to the inlet uniformly.
- Drill weep holes into the side of the inlet.
- Protect weep holes with screen wire and washed aggregate.
- Seal weep holes when removing structure and stabilizing area.
- It may be necessary to build a temporary dike to the down slope side of the structure to prevent bypass flow.

*Block and Gravel Filter* - A barrier formed around the storm drain inlet with standard concrete blocks and gravel. See Figure.

- Height 1 to 2 feet above inlet.
- Recess the first row 2 inches into the ground for stability.
- Support subsequent courses by placing a 2x4 through the block opening.
- Do not use mortar.
- Lay some blocks in the bottom row on their side for dewatering the pool.
- Place hardware cloth or comparable wire mesh with ½-inch openings over all block openings.
- Place gravel just below the top of blocks on slopes of 2:1 or flatter.
- An alternative design is a gravel donut or wattle.

- 1-foot wide level stone area between the structure and the inlet.

*Gravel and Wire Mesh Filter* - A gravel barrier placed over the top of the inlet. This structure does not provide an overflow.

- Hardware cloth or comparable wire mesh with ½-inch openings.
- Coarse aggregate.
- Height 1-foot or more, 18 inches wider than inlet on all sides.
- Place wire mesh over the drop inlet so that the wire extends a minimum of 1-foot beyond each side of the inlet structure.
- If more than one strip of mesh is necessary, overlap the strips.
- Place coarse aggregate over the wire mesh.
- The depth of the gravel should be at least 12 inches over the entire inlet opening and extend at least 18 inches on all sides.

*Catchbasin and Curb Inlet Filters* – Inserts must be installed according to manufacturer’s details and requirements. Inspection and maintenance may be required often based on sediment loads and rainfall events.

- For Nyloplast curb inlets, use Storm-PURE Catch Basin Insert or approved equal.
- For standard concrete curb inlets, use Siltsack manufactured by ACF Environmental, or approved equal.
- High-flow bypass that will not clog under normal use at a construction site.
- The catchbasin filter is inserted in the catchbasin just below the grating.

*Curb Inlet Protection with Straw Bales or Waddle* – Barrier formed around a curb inlet with straw bales or barrier using commercially available “waddle” products which incorporate filtering material or media. Install “waddle” applications according to manufacturer’s specifications.

*Block and Gravel Curb Inlet Protection* – Barrier formed around an inlet with concrete blocks and gravel. See Figure.

- Wire mesh with ½-inch openings.

- Place two concrete blocks on their sides abutting the curb at either side of the inlet opening. These are spacer blocks.
- Place a 2x4 stud through the outer holes of each spacer block to align the front blocks.
- Place blocks on their sides across the front of the inlet and abutting the spacer blocks.
- Place wire mesh over the outside vertical face.
- Pile coarse aggregate against the wire to the top of the barrier.

*Curb and Gutter Sediment Barrier* – Sandbag, rock berm or straw bale 2 feet high and 2 feet wide in a horseshoe shape. See Figure.

- Construct a horseshoe shaped berm, faced with coarse aggregate if using riprap, 2 feet high and 2 feet wide, at least 2 feet from the inlet.
- Construct a horseshoe shaped sedimentation trap on the outside of the berm sized to sediment trap standards for protecting a culvert inlet.

### ***Maintenance Standards***

- Catch basin filters should be inspected frequently, especially after storm events. If the insert or bag becomes clogged or fills to 50% capacity, it should be cleaned or replaced.
- For systems using stone filters: If the stone filter becomes clogged with sediment, the stones must be pulled away from the inlet and cleaned or replaced. Since cleaning of gravel at a construction site may be difficult, an alternative approach would be to use the clogged stone as fill and put fresh stone around the inlet.
- Do not wash sediment into storm drains while cleaning. Spread all excavated material evenly over the surrounding land area or stockpile and stabilize as appropriate.

### Plan View

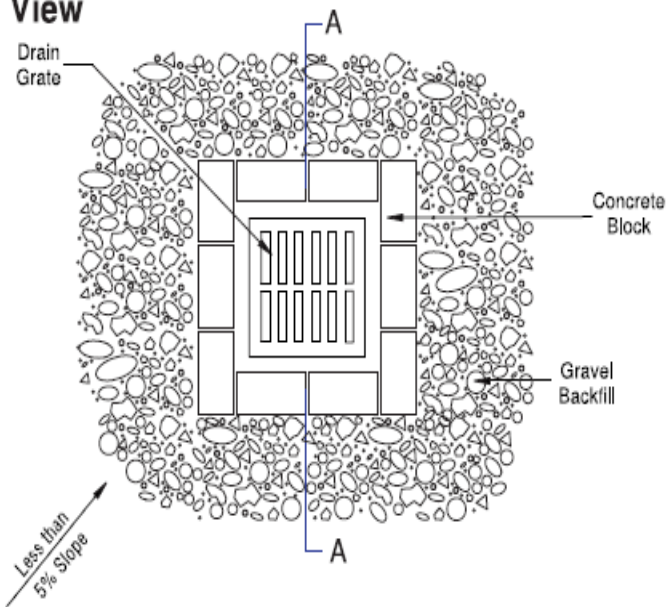

### Section A - A

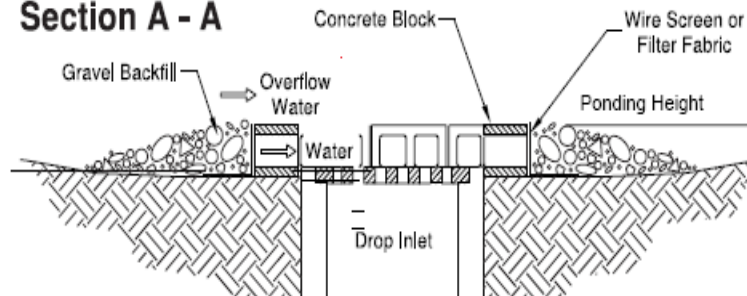

Notes:

1. Drop inlet sediment barriers are to be used for small, nearly level drainage areas. (less than 5%)
2. Excavate a basin of sufficient size adjacent to the drop inlet.
3. The top of the structure (ponding height) must be well below the ground elevation downslope to prevent runoff from bypassing the inlet. A temporary dike may be necessary on the downslope side of the structure.

**Figure 4.14 – Block and Gravel Filter**



## Plan View

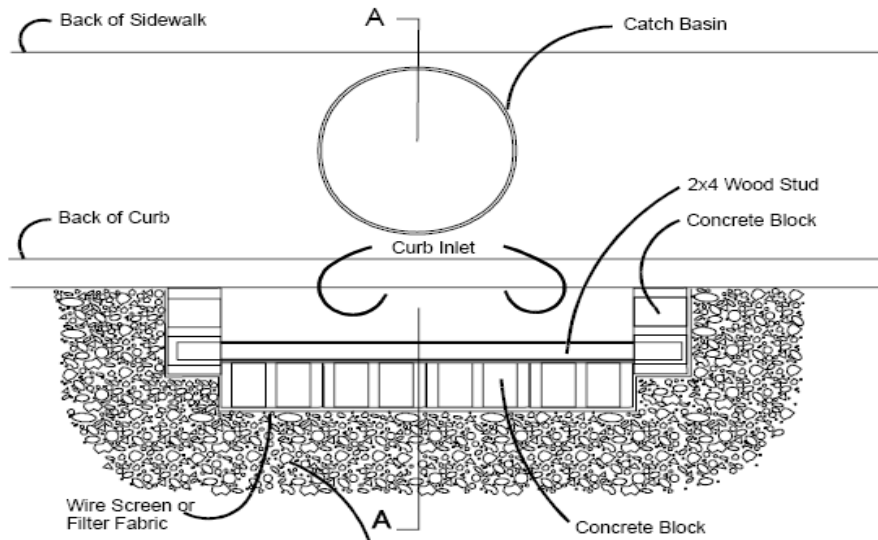

## Section A - A

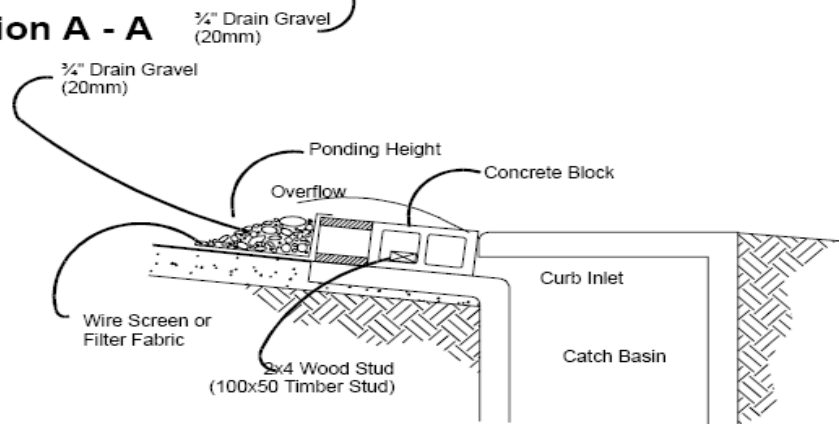

### NOTES:

1. Use block and gravel type sediment barrier when curb inlet is located in gently sloping street segment, where water can pond and allow sediment to separate from runoff.
2. Barrier shall allow for overflow from severe storm event.
3. Inspect barriers and remove sediment after each storm event. Sediment and gravel must be removed from the traveled way immediately.

**Figure 4.15 – Block and Gravel Curb Inlet Protection**

## Plan View

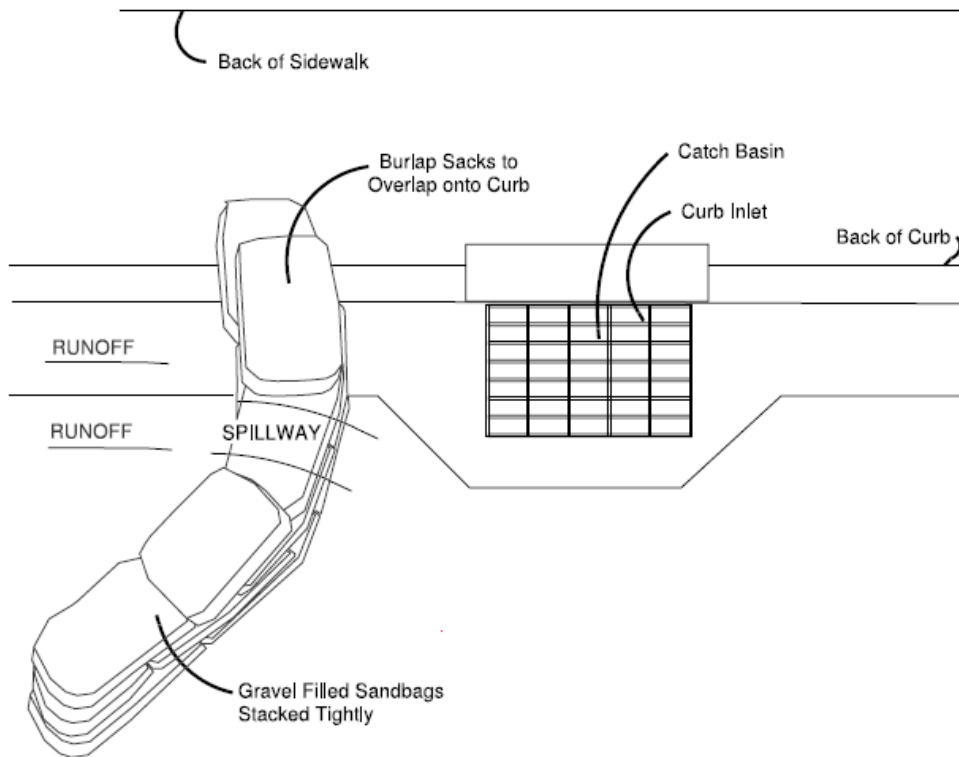

### NOTES:

1. Place curb type sediment barriers on gently sloping street segments, where water can pond and allow sediment to separate from runoff.
2. Sandbags of either burlap or woven 'geotextile' fabric, are filled with gravel, layered and packed tightly.
3. Leave a one sandbag gap in the top row to provide a spillway for overflow.
4. Inspect barriers and remove sediment after each storm event. Sediment and gravel must be removed from the traveled way immediately.

## **BMP C233: SILT FENCE**

### ***Purpose***

Use of a silt fence reduces the transport of coarse sediment from a construction site by providing a temporary physical barrier to sediment and reducing the runoff velocities of overland flow. See Figure for details on silt fence construction.

### **Conditions of Use**

Silt fence may be used downslope of all disturbed areas.

- Silt fence is not intended to treat concentrated flows, nor is it intended to treat substantial amounts of overland flow. Any concentrated flows must be conveyed through the drainage system to a sediment pond. The only circumstance in which overland flow can be treated solely by a silt fence, rather than by a sediment pond, is when the area draining to the fence is one acre or less and flow rates are less than 0.5 cfs.
- Silt fences should not be constructed in streams or used in V-shaped ditches. They are not an adequate method of silt control for anything deeper than sheet or overland flow.

### ***Design and Installation Specifications***

- Used for drainage areas resulting in sheet or overland flow rather than concentrated flows.
- Maximum slope steepness (normal (perpendicular) to fence line) 2:1.
- Maximum sheet or overland flow path length to the fence of 150 feet.
- No flows greater than 0.5 cfs.
- The geotextile used shall meet the following standards. All geotextile properties listed below are minimum average roll values (i.e., the test result for any sampled roll in a lot shall meet or exceed the values shown in the following Table):
  - Standard strength fabrics shall be supported with wire mesh, chicken wire, 2-inch x 2-inch wire, safety fence, or jute mesh to increase the strength of the fabric. Silt fence materials are available that have synthetic mesh backing attached.
  - Filter fabric material shall contain ultraviolet ray inhibitors and stabilizers to provide a minimum of six months of expected usable construction life at a temperature range of 0°F. to 120°F.
- Standard Notes for construction plans and specifications follow. Refer to Figure for standard silt fence details.

The contractor shall install and maintain temporary silt fences at the locations shown in the Plans. The silt fences shall be constructed in the areas of clearing, grading, or drainage prior to starting those activities. A silt fence shall not be considered temporary if the silt fence must function beyond the life of the contract. The silt fence shall prevent soil carried by runoff water from going beneath, through, or over the top of the silt fence, but shall allow the water to pass through the fence.

The minimum height of the top of silt fence shall be 2 feet and the maximum height shall be 2½ feet above the original ground surface.

The geotextile shall be attached on the up-slope side of the posts and support system with staples, wire, or in accordance with the manufacturer's recommendations. The geotextile shall be attached to the posts in a manner that reduces the potential for geotextile tearing at the staples, wire, or other connection device. Silt fence back-up support for the geotextile in the form of a wire or plastic mesh is dependent on the properties of the geotextile selected for use. If wire or plastic back-up mesh is used, the mesh shall be fastened securely to the up-slope of the posts with the geotextile being up-slope of the mesh back-up support.

The geotextile at the bottom of the fence shall be buried in a trench to a minimum depth of 4 inches below the ground surface. The trench shall be backfilled and the soil tamped in place over the buried portion of the geotextile, such that no flow can pass beneath the fence and scouring cannot occur. When wire or polymeric back-up support mesh is used, the wire or polymeric mesh shall extend into the trench a minimum of 3 inches.

The fence posts shall be placed or driven a minimum of 18 inches. A minimum depth of 12 inches is allowed if topsoil or other soft subgrade soil is not present and a minimum depth of 18 inches cannot be reached. Fence post depths shall be increased by 6 inches if the fence is located on slopes of 3:1 or steeper and the slope is perpendicular to the fence. If required post depths cannot be obtained, the posts shall be adequately secured by bracing or guying to prevent overturning of the fence due to sediment loading.

Silt fences shall be located on contour as much as possible, except at the ends of the fence, where the fence shall be turned uphill such that the silt fence captures the runoff water and prevents water from flowing around the end of the fence. If the fence must cross contours, with the exception of the ends of the fence, gravel check dams placed perpendicular to the back of the fence shall be used to minimize concentrated flow and erosion along the back of the fence. The gravel check dams shall be approximately 1- foot deep at the back of the fence. It shall be continued perpendicular to the fence at the same elevation until the top of the check dam intercepts the ground surface behind the fence. The gravel check dams shall consist of crushed surfacing base course, gravel backfill for walls, or shoulder ballast. The gravel check dams shall be located every 10 feet along the fence where the fence must cross contours. The slope of the fence line where contours must be crossed shall not be steeper than 3:1.

Wood, steel or equivalent posts shall be used. Wood posts shall have minimum dimensions of 2 inches by 2 inches by 3 feet minimum length, and shall be free of defects such as knots, splits, or gouges.

Steel posts shall consist of either size No. 6 rebar or larger, ASTM A 120 steel pipe with a minimum diameter of 1-inch, U, T, L, or C shape steel posts with a minimum weight of 1.35 lbs./ft. or other steel posts having equivalent strength and bending resistance to the post sizes listed. The spacing of the support posts shall be a maximum of 6 feet.

Fence back-up support, if used, shall consist of steel wire with a maximum mesh spacing of 2 inches, or a prefabricated polymeric mesh. The strength of the wire or polymeric mesh shall be equivalent to or greater than 180 lbs. grab tensile strength. The polymeric mesh must be as resistant to ultraviolet radiation as the geotextile it supports.

### ***Maintenance Standards***

- Any damage shall be repaired immediately.
- If concentrated flows are evident uphill of the fence, they must be intercepted and conveyed to a sediment pond or other suitable control.
- It is important to check the uphill side of the fence for signs of the fence clogging and acting as a barrier to flow and then causing channelization of flows parallel to the fence. If this occurs, replace the fence or remove the trapped sediment.
- Sediment deposits shall either be removed when the deposit reaches approximately one-third the height of the silt fence, or a second silt fence shall be installed.
- If the filter fabric (geotextile) has deteriorated due to ultraviolet breakdown, it shall be replaced.

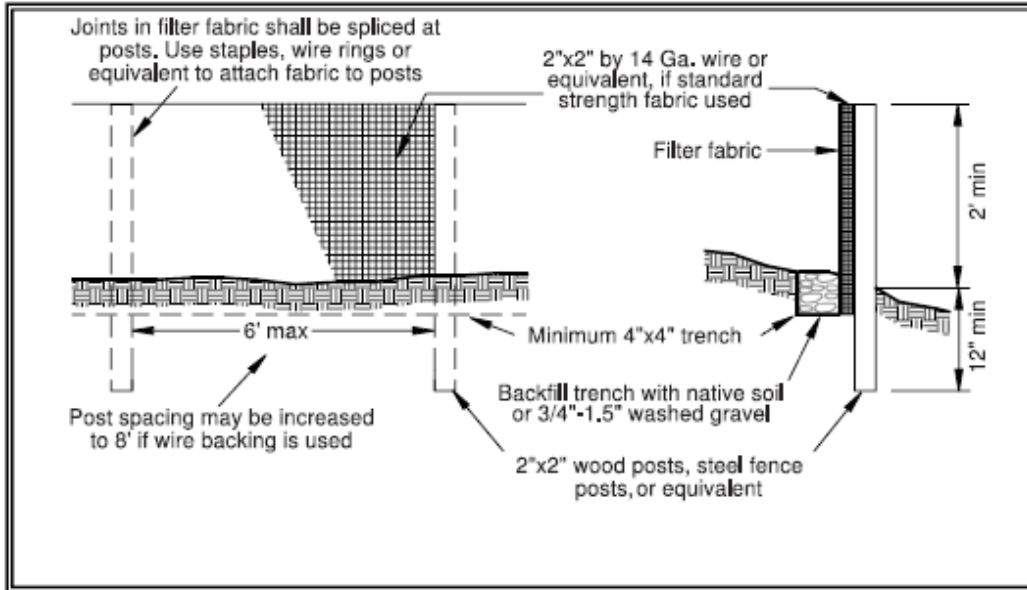

**Silt Fence**

<b>Geotextile Standards</b>	
Polymeric Mesh AOS (ASTM D4751)	0.60 mm maximum for slit film wovens (#30 sieve). 0.30 mm maximum for all other geotextile types (#50 sieve). 0.15 mm minimum for all fabric types (#100 sieve).
Water Permittivity (ASTM D4491)	0.02 sec <sup>-1</sup> minimum
Grab Tensile Strength (ASTM D4632)	180 lbs. Minimum for extra strength fabric. 100 lbs minimum for standard strength fabric.
Grab Tensile Strength (ASTM D4632)	30% maximum
Ultraviolet Resistance (ASTM D4355)	70% minimum

## **BMP C254: STRAW WATTLE**

### *Purpose*

Straw wattles are temporary erosion and sediment control barriers consisting of straw that is wrapped in biodegradable tubular plastic or similar encasing material. They reduce the velocity and can spread the flow of rill and sheet runoff, and capture and retain sediment. Straw wattles are typically 8 to 10 inches in diameter and 25 to 30 feet in length. The wattles are placed in shallow trenches and placed with stakes, rebar, or sand bags along the contour of disturbed or newly constructed slopes or at the base of concrete or asphalt surfaces.

### *Conditions of Use*

- Disturbed areas that require immediate erosion protection.
- Exposed soils or hard surfaces during the period of short construction delays, or over winter months.
- On slopes requiring stabilization until permanent vegetation can be established.
- Straw wattles are effective for one to two seasons.
- If conditions are appropriate, wattles can be staked to the ground using willow cuttings for added revegetation.
- Rilling can occur beneath wattles if not properly entrenched and water can pass between wattles if not tightly abutted together.

### *Design and Installation Specifications*

- It is critical that wattles are installed perpendicular to the flow direction and parallel to the slope contour.
- Narrow trenches should be dug across the slope of contour to a depth of 3 to 5 inches on clay soils and soils with gradual slopes. On loose soils, steep slopes, and areas with high rainfall, the trenches should be dug to a depth of 5 to 7 inches, or  $\frac{1}{2}$  to  $\frac{2}{3}$  of the thickness of the wattle. On asphalt or concrete surfaces, wattles should be placed at the base of the slope with compacted soil on the upslope side. Sandbags should be used when wattles are placed on concrete, asphalt, or other hard surfaces.
- Start building trenches and installing wattles from the base of the slope and work up. Excavated material should be spread evenly along the uphill slope and compacted using hand tamping or other methods.

- Construct trenches at contour intervals of 3 to 30 feet apart depending on the steepness of the slope, soil type, and rainfall. The steeper the slope the closer together the trenches.
- Install the wattles snugly into the trenches and abut tightly end to end. Do not overlap the ends.
- Install stakes, rebar, or sandbags at each end of the wattle, and at a minimum 4-foot centers along entire length of wattle.
- If necessary, install pilot holes for the stakes using a straight bar to drive holes through the wattle and into the soil.
- At a minimum, wooden stakes should be approximately  $\frac{3}{4}$  x  $\frac{3}{4}$  x 24 inches. Willow cuttings or  $\frac{3}{8}$ -inch rebar can also be used for stakes.

### ***Maintenance Standards***

- Stakes or rebar should be driven through the middle of the wattle, leaving 2 to 3 inches of the stake or rebar protruding above the wattle.
- Wattles may require maintenance to ensure they are in contact with soil or surface and thoroughly entrenched, especially after significant rainfall on steep sandy soils.
- Inspect the slope after significant storms and repair any areas where wattles are not tightly abutted or water has scoured beneath the wattles.



