

SADDELBRED ACRES SUBDIVISION

PART OF THE NORTHEAST 1/4 OF SECTION 28, TOWNSHIP 6 NORTH, RANGE 2 WEST, SALT LAKE BASE & MERIDIAN, U.S. SURVEY
WEBER COUNTY, UTAH

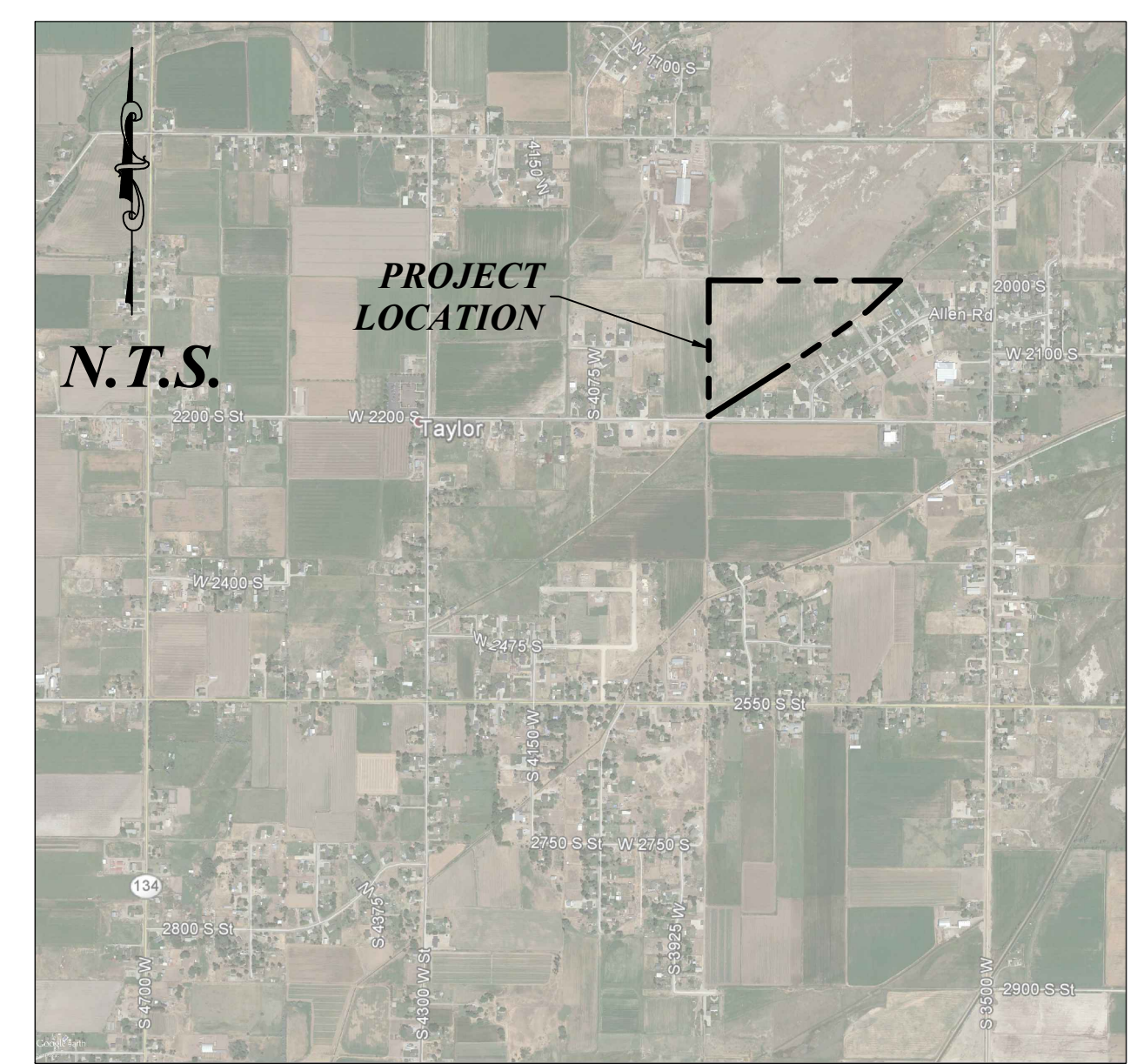
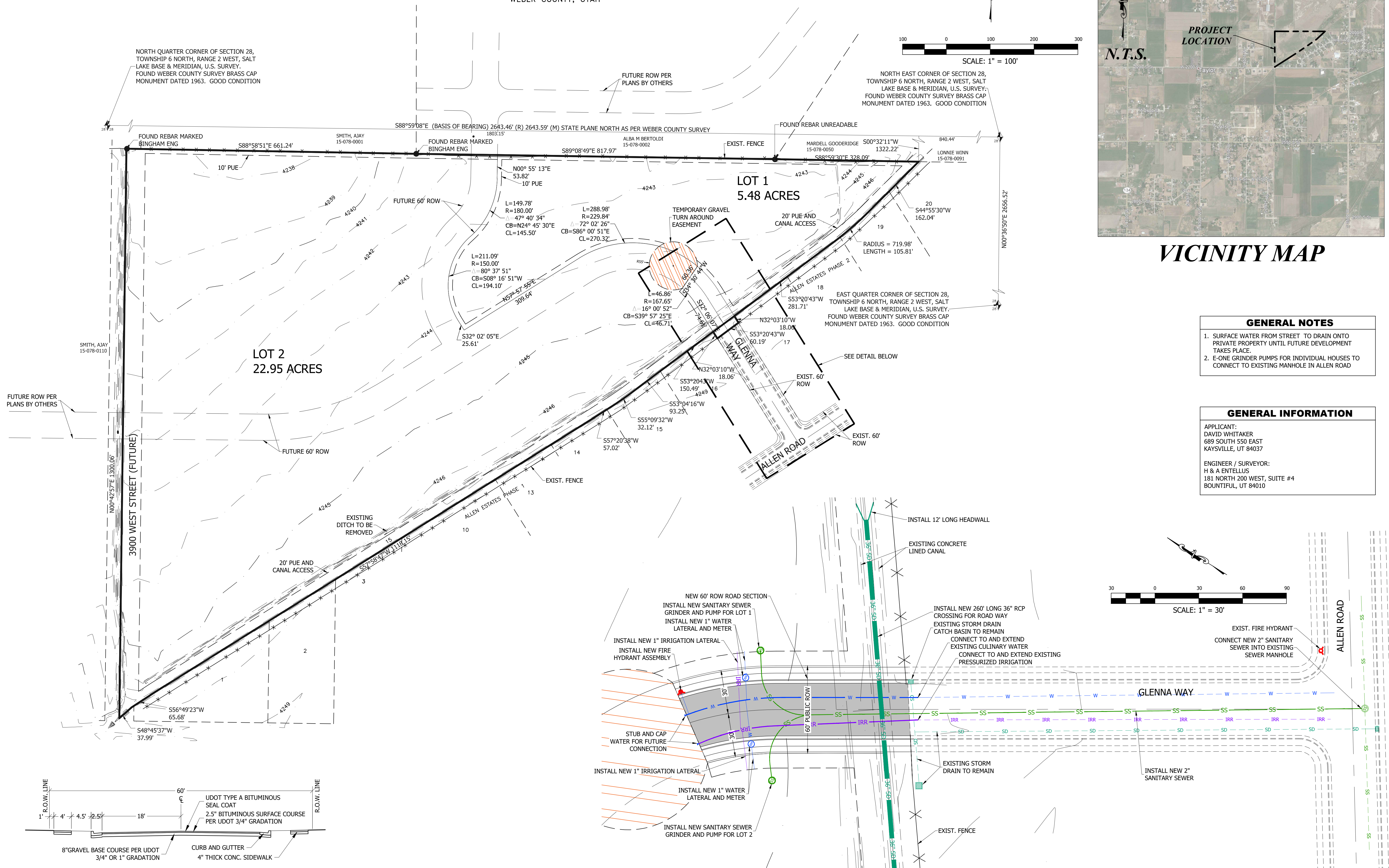

GENERAL NOTES

- SURFACE WATER FROM STREET TO DRAIN ONTO PRIVATE PROPERTY UNTIL FUTURE DEVELOPMENT TAKES PLACE.
- E-ONE GRINDER PUMPS FOR INDIVIDUAL HOUSES TO CONNECT TO EXISTING MANHOLE IN ALLEN ROAD

GENERAL INFORMATION

APPLICANT:
DAVID WHITAKER
689 SOUTH 550 EAST
KAYSVILLE, UT 84037

ENGINEER / SURVEYOR:
H & A ENTELLUS
181 NORTH 200 WEST, SUITE #4
BOUNTIFUL, UT 84010

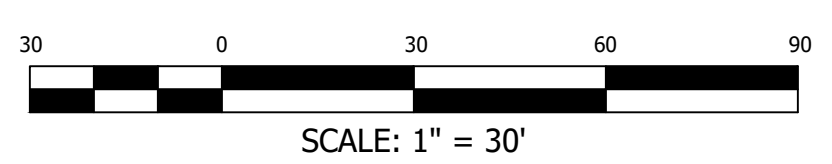
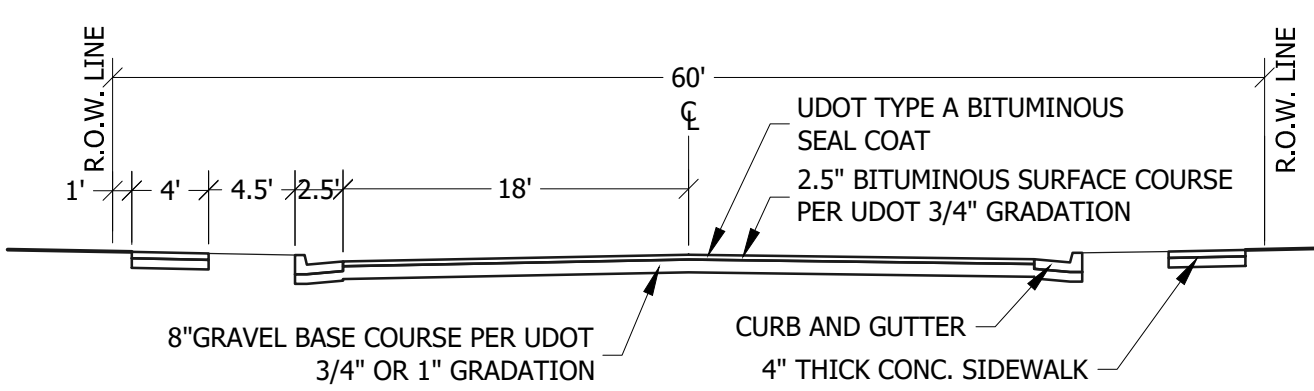

181 North 200 West, Suite #4
Bountiful, Utah 84010
Phone 801-298-2236

PRELIMINARY SUBDIVISION PLAN

SADDELBRED ACRES SUBDIVISION

Parcel # 15-078-0006

LOCATED IN THE NE 1/4 OF SECTION 28, T.6N., R.2W., S.L.B.&M.
TAYLOR CITY, WEBER COUNTY, UTAH

DATE:	DESCRIPTION:
06/29/2017	DRAWN: JKS
06/29/2017	APPROVED: STA
1034014	PROJECT: 1034014 Preliminary.dwg

C400
PRELIMINARY SUBDIVISION PLAN